

# Fuzzy-PID Controller of Robotic Grinding Force Servo System

Adnan Jabbar Attiya<sup>\*1,2</sup>, Yang Wenyu<sup>1</sup>, Salam Waley Shneen<sup>3</sup>

<sup>1</sup>School of Mechanical Science and Engineering,  
Huazhong University of Science and Technology (HUST), Luoyu Road 1037, Wuhan 430074, China

<sup>2</sup>Alkwarizmi Engineering college / Baghdad University, Baghdad, Iraq

<sup>3</sup>Huazhong University of Science and Technology (HUST)/University of Technology, Baghdad, Iraq

\*Corresponding author, email: rainman3009@yahoo.com

## Abstract

When a robot is used to grind or finish a curved surface, as marine propeller surface, both contact force and feed movement must be controlled at the similar time in order that the grinding tool would machine the work-piece, with required force, at the right position in right posture. A compliant wrist system is advanced, in this paper, to conform the shape of the machining propeller by altering its posture along with the surface. Grinding force is controlled under a simple new Fuzzy-PID controller with five input variables which assembled and compared with an antecedently used PID controller. The aim of defining the rules and its optimization are to achieve a controller that provides grinding with higher quality. Both the controllers PID and Fuzzy-PID have been optimized together with the parameters of the Two-Phase Hybrid Stepping Motor. The Fuzzy-PID controller policy at a steady value in the normal direction of the mentioned machining point by multi-point machining, while the grinding tool moving along the curved surface of the propeller. It means that the model of the compliant wrist system and the surroundings could be used in force controlling when robots grind marine propeller surface by a grinding tool with multi-point machining.

**Keywords:** force control, grinding robot, PID controller, fuzzy logic controller, PID-Fuzzy controller, two-phase hybrid stepping motor, marine propeller

Copyright © 2015 Institute of Advanced Engineering and Science. All rights reserved.

## 1. Introduction

Grinding is a chip-removing process fundamental used to remove burrs and metal from machined parts in order to accomplish the desired surface finish. In many cases, manual grinding means monotonous and hard work in a noisy environment. The workers required to use protective equipment. So this leads to automation of the grinding process. Robotic grinding, in early industrial applications, was resolved using a grinding machine attached to the end effector of robot through a damper and spring arrangement. The requested contact force between the grinding tool and the workpiece was achieved by programming the robot's position to be slightly under the workpiece surface. It was difficult to control the depth of cut and accomplish optimal grinding conditions because of alterations in the grinding tool and workpiece geometry wear would cause alterations in the contact forces. Also, the workpiece geometry was required to be measured regularly, which was quite boring. Therefore, there was a require for an intelligent robot control system and more flexible taking care of the requirements from the grinding process [1]. In the process of grinding and finishing, grinding force needs to be actively controlled both in direction and in value all the time along with feed movement controlling, thus the process requires to be controlled by the policy of compliant controlling. When the force controlled robot is applied to grinding operation, the position control style is selected to control the grinding tool path in the feed direction exactly. In the press direction, which is perpendicular to the feed direction, the compliance control style or force control style is selected to get the appropriate contact force. It is essential to maintain a suitable amount of contact force is two cases for the grinding operation [2]. The first is surface grinding or deburring the machined parts in which a grinding tool traces the workpiece profile. The second is bead grinding or deburring the forged or cast parts, in which the perfect profile must be accomplished after grinding. Either compliance control or force control can be chosen. The difference in grinding between using compliance control and force control is as explained in the coming section. In the force control style, the

grinding tool follows the surface of workpiece by maintaining the contact force constant. So it is possible to follow an unknown curved surface. The grinding process can be finished easily without taking into account the position errors like for example in setting the workpiece that is the problem when using a position controlled robot. This style therefore is most successfully for grinding a surface usually made or in small deburring of machined parts. In the compliance control style, the requested profile of the workpiece surface after grinding process performs as the reference position; also the contact force is accomplished by contraction or expansion of virtual spring. So it is possible to produce a target profile after grinding. Then, it must be compensate the large error of workpiece position that can't be corrected by virtual spring. This style is appropriate for grinding to get a target profile as an example of large deburring of casting. Force control is used to preserve a constant force on the part during the marine propeller grinding process in order to provide equally grinding on the whole surface.

Passive compliance is an additional tool or a device attached to the robot end-effector to provide a flexibility for it and has a number of advantages including: Passive compliance is useful for the self-correction of positioning errors in assembly, normally reduce the high forces or moments produced in wedging or jamming, passive compliance protect the assembled surfaces from damage, such as a galling or scraping; it is useful also for adaptation to the impermanent state control and force control. In a robotic grinding procedure, it is essential to perform the workpiece given geometry, so it is commonly required that the robot performs a given path while preserving the contact between the grinding tool and the workpiece. Any divergences from the programmed path arise from an increase of the contact force or yet in the loss of contact. This contact force is demanded to be maintained within a given value to assure that the tool can perform the material removal [3]. From control is attained, the velocity or force may be not continuous and the control becomes uncertain. In this condition, a passive compliance which attached to the robot end-effector near the contact point will absorbed the kinetic energy and could avoid the possible high forces or moments, therefore, the lack of continuity is accommodated and performance of the complete system is smoothed [4]. Also, when the robot is equipped with passive compliance, a high gain of the force control can be chosen. So, for the system that contains passive compliance, the permitted force control gain is higher than that without it, which is desirable for improving performance and sensitiveness of force control.

This paper presents a helix spring and compliant wrist to be the passive compliance additional tools. The hybrid movement–force control policy is the best way for a compliant control system to deal with the coupling of the force control subsystem and the movement control subsystem. A compliant wrist system is improved, in this paper, to conform the shape of the propeller machining surface, and the proposed controller will be Fuzzy proportional–integral–derivative controller or Fuzzy-PID control strategy, it is used to deal with the robots' position changing. In this method, force control is fulfilled in the normal direction of the mentioned machining point by multi-point machining during a grinding wheel moving along the curved surface of the propeller. The conventional proportional–integral– derivative (PID) controllers stay to be the most prevalently used in the industrial processes in spite of the many complicated control techniques and theories that have been invented in the last few decades [5]. In practice, most physical systems have essentially ungovernable characteristics such as non-linearities and high order. Hence, the type of achieving the parameters of PID controllers that satisfy the execution requirement has been referred in many studies [6]. The famous method, Ziegler–Nichols method, supplies a systematic tuning method for the PID parameters which has good load disturbance reduction but, with a long settling time and large overshoot it shows disappointing performance. For improving systems' performance, such as, overshoot, rise time, and integral of the absolute error, many studies are endeavoring to combine features on the basis of the experiences of specialists with regard to PID gain scheduling, and the utilize of fuzzy logic appears to be especially suitable. Lately, fuzzy PID controllers have been displayed and inspected, and their adequate performance in several plants has been exhibited. Fuzzy PID controller is often mentioned as a substitute to classical PID controllers for high non linearity and complex cases. It supplied a favorable option for industrial applications with many worthwhile features, as it has the ability to on-line adaptation to time varying, nonlinear, and uncertain systems [7-9]. The PID controller attempts to minimize the error by modifying the process control input [10]. As a model free control design approach, Fuzzy logic control was earlier introduced and developed. It has been used with great successful in industry

applications. In the past decade, common research attempts on fuzzy logic control have been dedicated to model-based fuzzy control systems that assure stability and the closed-loop fuzzy control systems performance. Fuzzy logic begins with and construct on user provide human language and transform these rules into mathematical equivalent. Fuzzy logic has a rare feature of simplicity and its flexibility to deal in problems with exactness and accuracy with its simulation results. it can be carried out in software or hardware or by joining of both of them.

## 2. Grinding Force Controlling Principle

Grinding force is determined as shown in Figure 1, into three component forces,  $F_n$  which is normal grinding force,  $F_t$  which is tangential grinding force and a component force which is acting along the longitudinal feed direction which is neglected, usually, because of its unimportance.

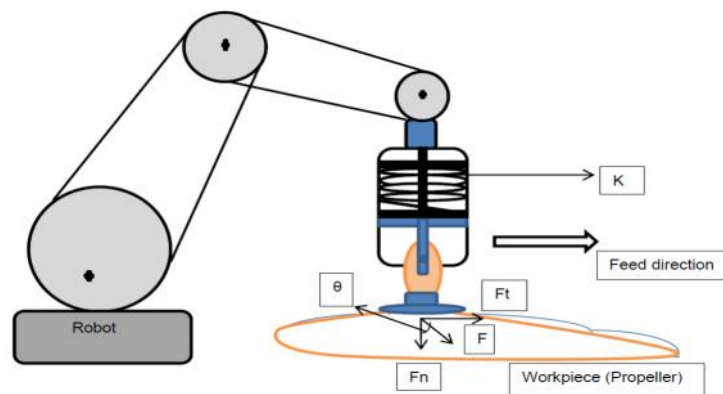

Figure 1. Main parameters used in grinding policies

The normal grinding force  $F_n$  has a affect on the workpiece roughness and the surface deformation, while the tangential grinding force  $F_t$  chiefly influences the consumption of power and providing the grinding wheel life [11]. As shown in Figure 2, the compacting force  $F_c$  is regulated by two sections: Two-Phase Hybrid Stepping Motor and a Helix spring, compliant wrist as a passive compliance.

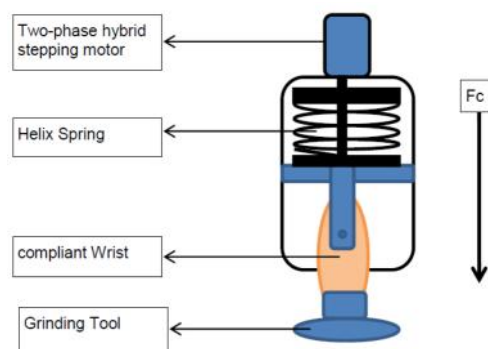

Figure 2. Model of the grinding force servo system

Two-phase hybrid stepping motor is a brushless DC electric motor which divides a full rotation into a number of equal steps [12]. The position of motor can afterwards be ruled to move and hold without any feedback sensor at one of these steps, while the motor is cautiously sized to the application. The Two-phase hybrid stepping motor is famously used in controlling

appliances with its dispositions of high precision , high torque output, low vibration and noisy, and low cost [13]. Thus, it is very significant that the control algorithm research applied in stepping motor.

Stepper motors are fast and executable in much performance hardware. The utilize of stepper motors has increased few years later as a result of:

- Its better reliability due to the mechanical brushes elimination,
- Higher torque-to-inertia ratio due to a lighter rotor,
- Its better heat dissipation due to that the windings are situated on the stator not on the rotor, and
- Inexpensive.

Originally, stepper motors were designed to be employed in open-loop. Their intrinsic stepping capability allows for perfect positioning without feedback, then closed-loop control of stepper motors has been employed to achieve more rapid response times and higher resolution capabilities. The stepper motor can also be operated at higher speeds, by taking into consideration nonlinear effects [14]. The stepper motor presses the helix spring when it works, and supplies the compressive force  $F_c$  for the force controlling system. By two perpendicular angle sensors, the two angles  $\alpha$  and  $\beta$  could be detected, and by a force sensor, the compressive force  $F_c$  is detected.

The displacement of the linear stepper motor, founded on the data from sensors, is changed to compress the spiral spring to modify the grinding force  $F_n$ . The grinding force controlling diagram is shown in Figure 3. It is based according to the strategy of hybrid movement-force control, in which  $F_n$  is the surroundings target force,  $F_m$  symbolizes the modifying force to change the adapting of force controlling if needed.

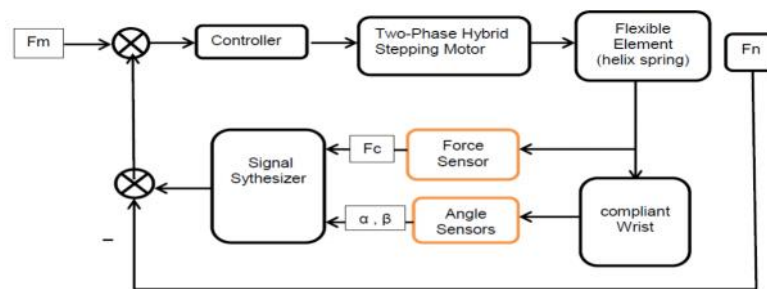

Figure 3. Block diagram of the force controlling system according to the strategy of hybrid movement-force control

The hardware system force controlling is designed, generally, by:

$$I_0 = (I_1 + I_2)/2 \quad (1)$$

$$F_n = k_f (I_2 - I_1) / 2 \quad (2)$$

$$F_t = \mu F_n \quad (3)$$

$$\mu = \tan \quad (4)$$

Where:

$I_0$  is the accurate displacement of the stepper motor when the grinding force at its desired value  $F_n$ ,

$I_1$  is the stepper motor greatest displacement ,

$I_2$  is the smallest displacement to compress the spiral spring,

$k_f$  is the elastic modulus of the spiral spring in Fig.1.

$F_t$  Tangential force and specific value per unit width, and

$\mu$  Grinding force ratio

### 3. The Model of the Two-phase Hybrid Stepping Motor

The transfer function  $G(s)$  of the open-loop system of the two-phase Hybrid Stepping Motor is as follows:

$$G(s) = A(s) / B1(s)+B2(s) \quad (5)$$

Where:

$$A(s) = Kpv + Klv / s + KDv s) (KPi s+ Kli )ke NKH \quad (6)$$

$$B1(s) = J L s^4 + (JR + L + JKPi KH) s^3 \quad (7)$$

$$B2(s) = Kli KH s + (JKli KH + R + KPi KH) s^2 \quad (8)$$

The subdivided driving is assumed for the Hybrid Stepping Motor in order to reach to the actual system performance parameter and to decrease the intricacy of the system transfer function. In simulation, the parameters of the two-phase Hybrid Stepping Motor selected are as follows:

Inductance  $L = 4.5 \text{ mH}$ , Resistance  $R = 1.3$  , Inertia Constant  $J = 270 \text{ kg} \cdot \text{m}$  ,  
Coefficient of Viscous Friction  $B = 0 \text{ N} \cdot \text{m} \cdot \text{s/rad}$ ,  $\theta = 1$ ,

$Kpv = 550$ ,  $Klv = 0$ ,  $KDv = 115$ ,

$ke = 0.25 \text{ N} \cdot \text{m/A}$ ,  $N = 180$ ,  $KH = 10$ ,  $Kli = 550$ ,  $KPi = 6$ .

Transfer function will be:

$$G(s) = 270000 s^2 + 28350000 s + 135000000 / s^4 + 19799 s^3 + 650000 s^2 + 7500s$$

### 4. Conventional PID Strategy for Grinding Force Servo Unit

The most conventional PID controller or linear PID controller is described as follows:

$$u(t) = K_p e(t) + K_i \int_0^t e(t) dt + K_D \frac{de(t)}{dt}$$

Where  $K_P$  is the proportional constant gain,  $K_I$  is the integral constant gain and  $K_D$  is the derivative constant gain according to manual expertise. The signal  $e(t)$  is the error signal between the reference and the process output  $c(t)$  it is explained as:

$$e(t) = r(t) - c(t)$$

Table 1. shows the effect of  $K_p$ ,  $K_i$  and  $K_d$  to the controlled system

parameter	Rise time	Overshoot	Turning time	Error
$K_p$	decrease	Increase	Small change	decrease
$T_i$	decrease	Increase	increase	eliminte
$T_d$	Small change	Decrease	decrease	Small change

The Simulink figure of PID controller is shown in Figure 4 and the PID controller internal structure is explained in Figure 5, the input parameters for the PID controller are  $K_p$ ,  $K_i$ ,  $K_d$ ,  $e$  and  $ec$ , the output for the controller is  $u$ .

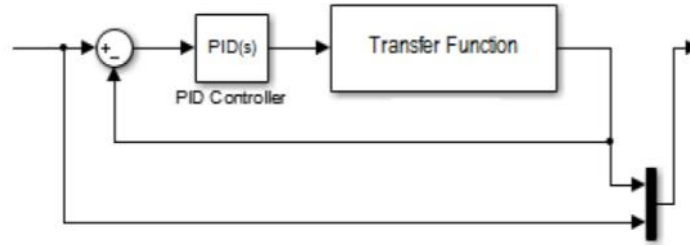

Figure 4. Simulink figure of PID controller

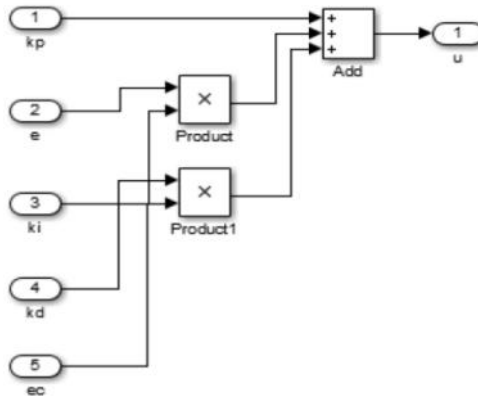

Figure 5. The structure for PID controller

**5. Fuzzy Controller Strategy for Grinding Force Servo Unit**

Fuzzy logic is widely used in processes where system dynamics is either very complex or show a extremely nonlinear character. The fuzzy controller operation can be described as shown in Figure 6:

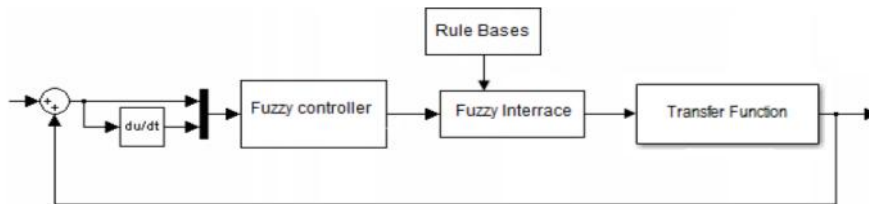

Figure 6. The structure for Fuzzy controller

In this paper, Fuzzy subsets of all inputs and outputs are total explained as {NB,NM,NS,Z,PS,PM,PB}. Elements of every subset refer to: negative large Nb, negative middle Nm, negative small Ns, zero Z, positive small Ps, positive middle Pm and positive large Pb.

We set the ranges {-6,6} for both e and ec , {-1,1} for both Kd and Ki . and {-3,4} for Kp as shown in Figure 7, 8, 9, 10, 11.

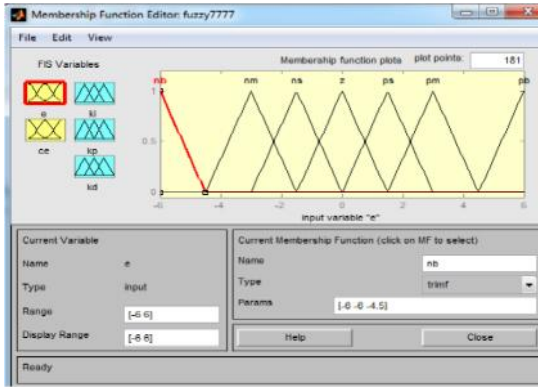

Figure 7. Membership error function (e)

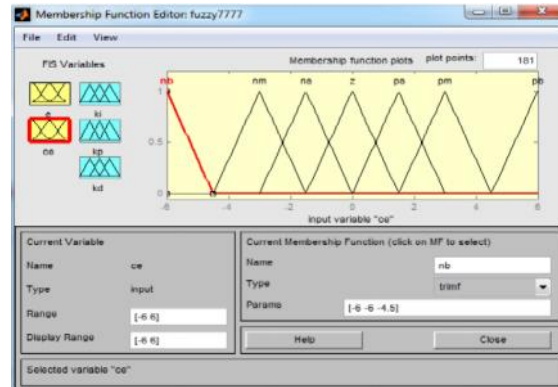

Figure 8. Membership change error function (ec) of fuzzy

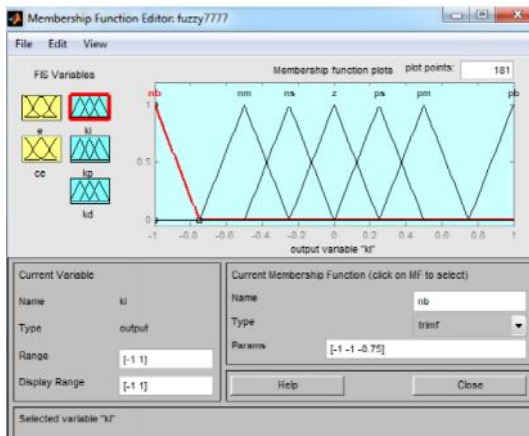

Figure 9. Membership Ki function of fuzzy controller

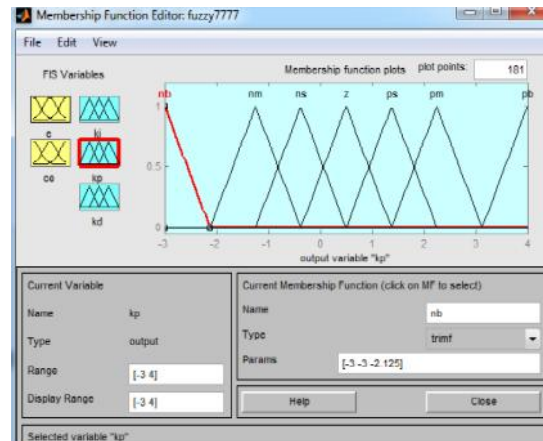

Figure 10. Membership Kp function controller

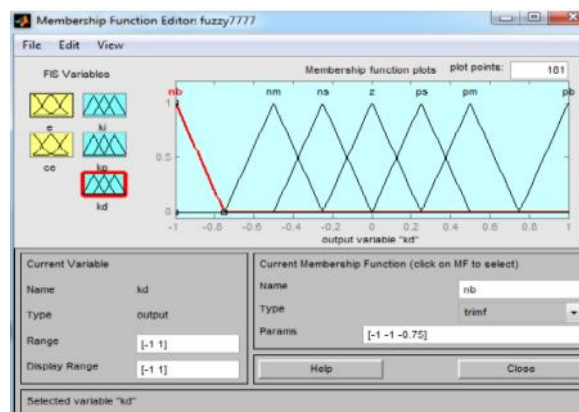

Figure 11. membership of Kd function

The surface view of Kp, Ki, and kd will be as shown in Figure 12, 13, 14.

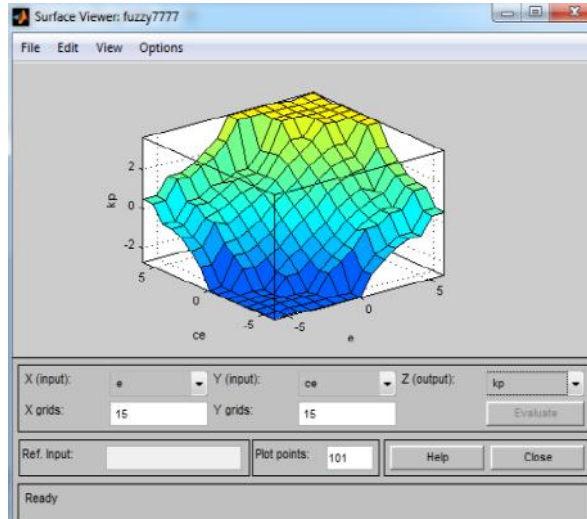

Figure 12. Surface view of  $K_p$  of fuzzy controller

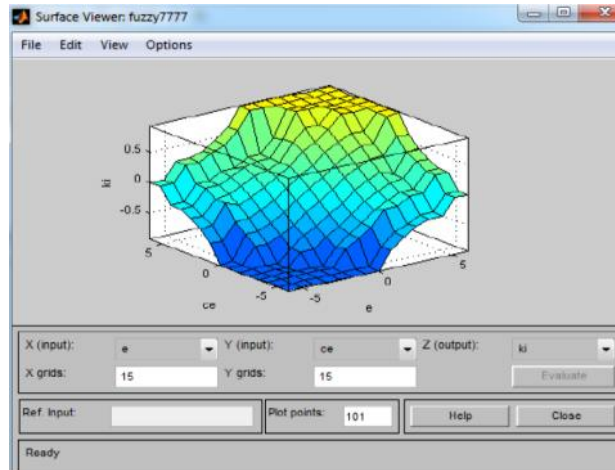

Figure 13. Surface view of  $K_i$  of fuzzy controller

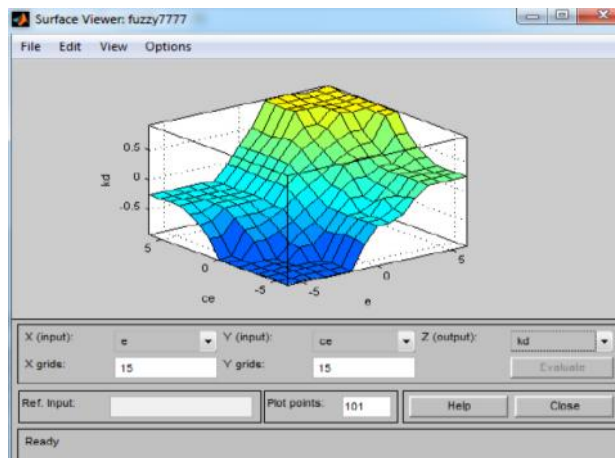

Figure 14. Surface view of  $K_d$  of fuzzy controller



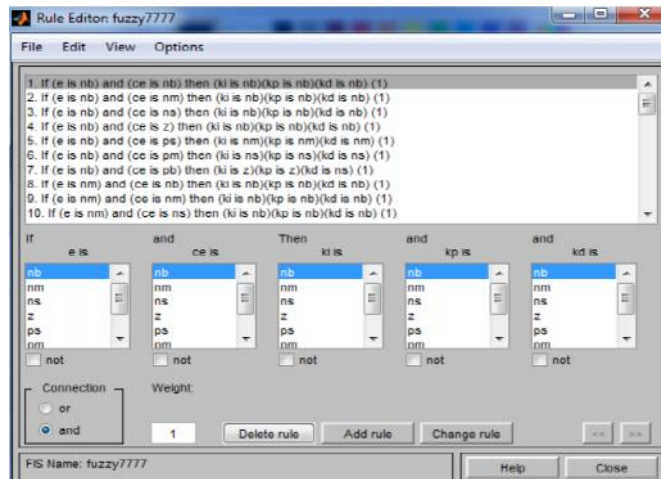

Figure 15. Rule bases for Fuzzy control system

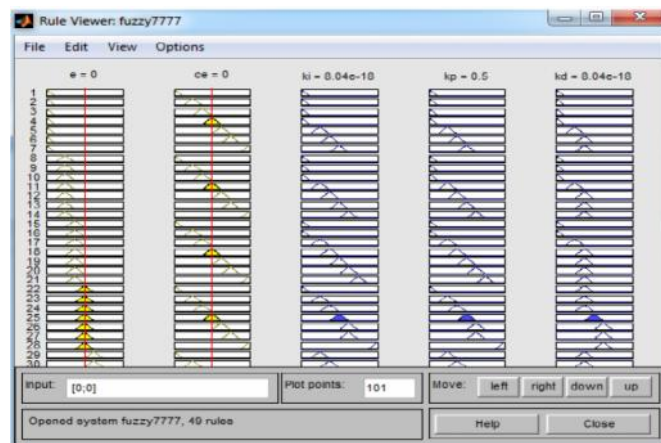

Figure 16. Rule bases view for Fuzzy control system

**6. Fuzzy-PID Strategy for Grinding Force Servo Unit**

In this paper, Fuzzy-PID strategy combines the Fuzzy optimizing strategy with the conventional PID algorithm. In this strategy, the optimal values for the three characteristic parameters of a PID controller are obtained by Fuzzy self-optimizing.

The Fuzzy-PID controller principle is shown in Figure 17, in which  $e$  refers to the error of the output from its desired value and  $ec = de/dt$

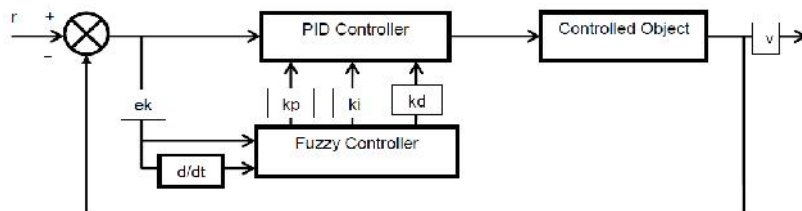

Figure 17. The structure of Fuzzy-PID controller

By Fuzzy optimizing, the values of the three characteristic parameters would be:  $Kp=200$ ,  $Ki=14.75$ ,  $Kd=3.6875$ .

In Figure 18, there are two inputs and three outputs for the Fuzzy Logic Controller, the inputs are (e) and (ec = d/dt), and the outputs are Kp, Ki and Kd.

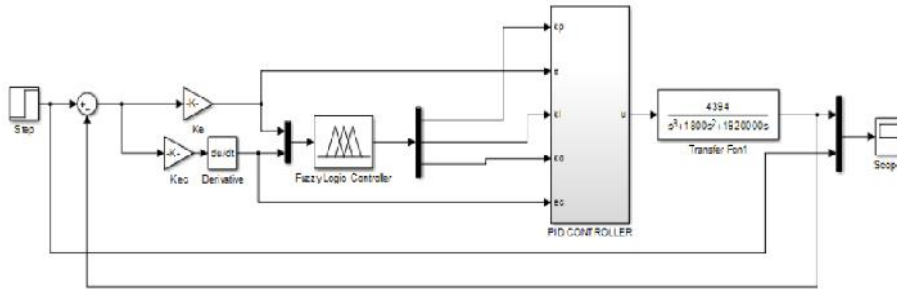

Figure 18. Fuzzy controller

With the MATLAB SIMULINK, a famous simulation software, and for a conventional PID controlling system, step response is also shown in Figure 4 with  $K_p= 200$ ,  $K_i=14.75$ ,  $K_d=3.6875$ .

Step response of the Fuzzy-PID controlling system is completely different from that of the conventional PID controlling system.

Remarkably, the Fuzzy-PID controller has improved the force servo system by deducing the optimized  $K_p$ ,  $K_i$  and  $K_d$ .

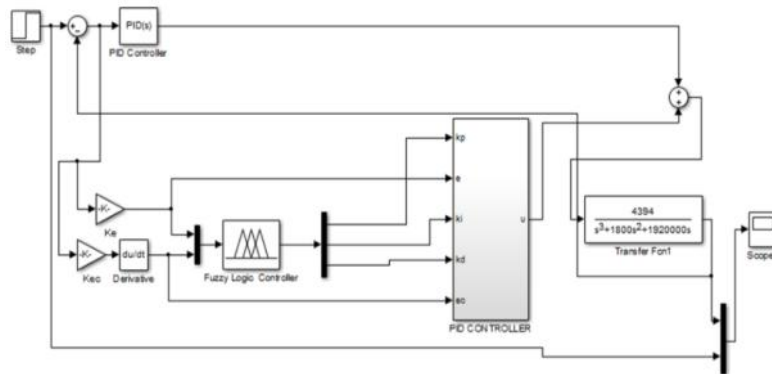

Figure 19. The fuzzy-pid simulation model in MATLAB

**7. Results and Discussion**

**7.1. PID Controller: Modeling**

Figure 20 shows the Simulink figure of PID controller. When  $K_p= 2$ ,  $T_i = 0.5$ ,  $T_d= 1$ , the simulation was performed in figure below:

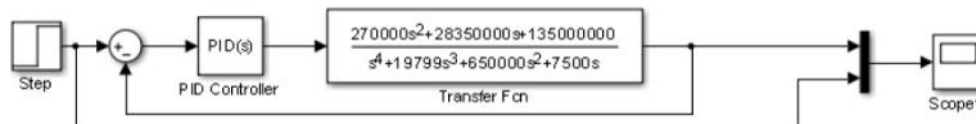

Figure 20. Simulink figure of PID controller

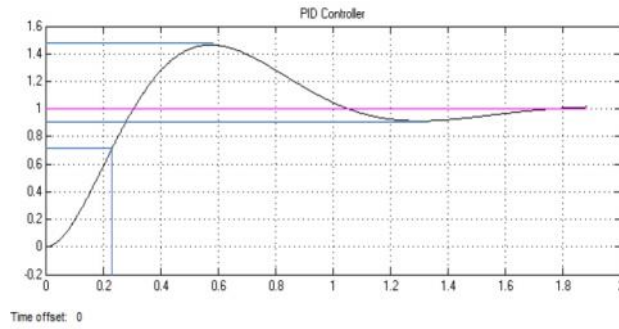

Figure 21. Step response of the system under PID controller

We note that the Rise time value = 0.23 and the overshoot value = 1.46 also we note that there is an undershoot value =0.9

**7.2. Fuzzy Controller: Modeling**

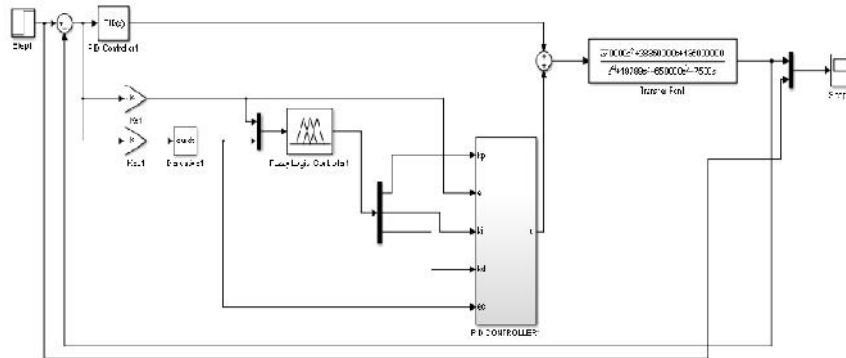

Figure 22. Simulink figure of Fuzzy controller

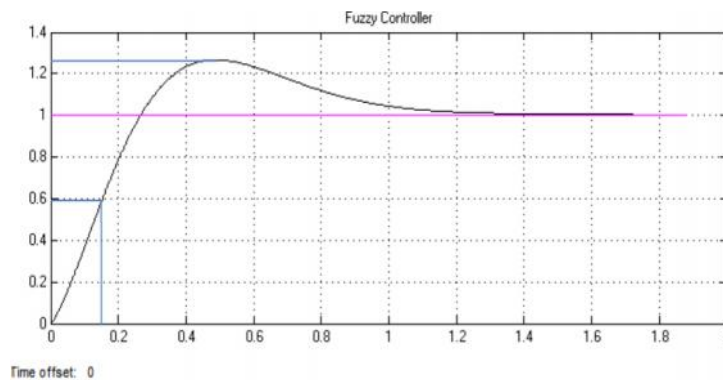

Figure 23. Step response of the system under PID controller

We note that the Rise time value = 0.17 and the overshoot value = 1.27 also we note that there is no an undershoot value.

### 7.3. Fuzzy PID Controller

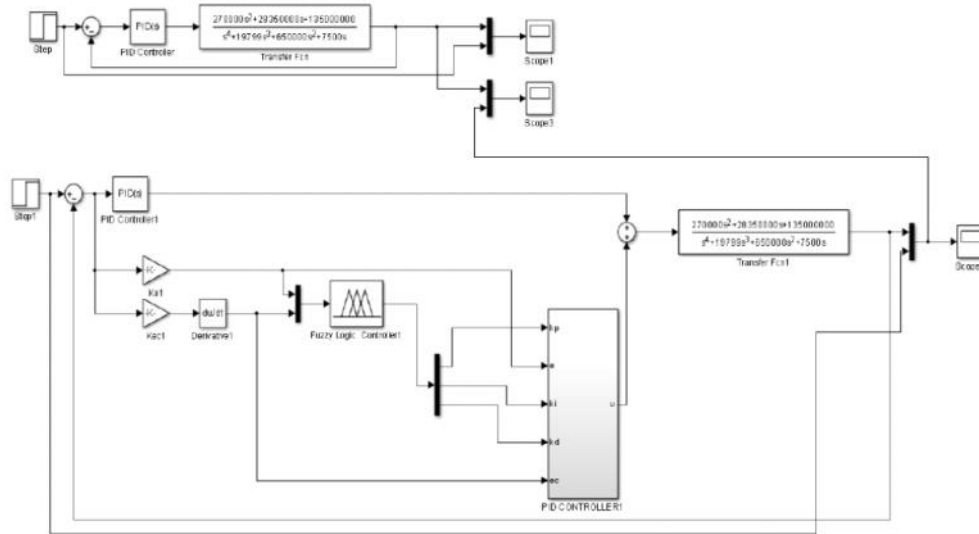

Figure 24. Simulink figure of Fuzzy-PID controller

Step response of the Fuzzy-PID controlling system is shown in Figure 25.

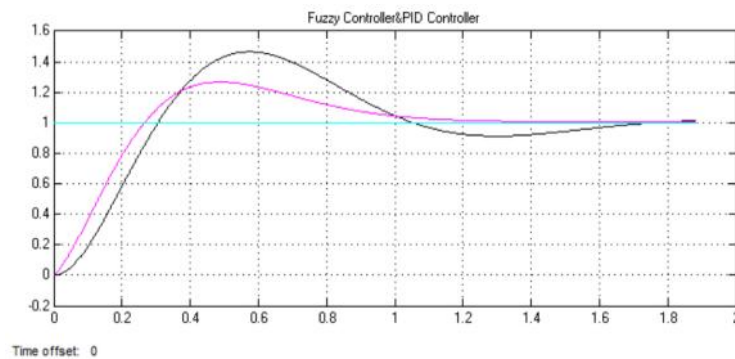

Figure 25. Step response of the system under PID controller

This could be close to optimal values for knowledgeable, but could be the optimum ones for any controlled system hardly.

## 8. Conclusion

When a grinding wheel grinds propellers as a free-form surface by a robot, the grinding force, at the mentioned machining point, must be controlled in the normal direction in order that both grinding force and feed movement could be controlled. Research works are taken for grinding force controlling in this paper.

(1) To make the grinding wheel conform the curved surface, compliant wrist system is improved. The wrist could change its attitude in perpendicular two directions to conform the machining surface according to a helix spring compressive force that driven by a stepper motor. In this way, the grinding wheel could grind the free-form surfaces of marine propellers.

(2) Whereas the controlling parameters would not be adapted with the attitude of the wrist altering and the controlling system is not capable of adapting one to the form of the

machining surface, the grinding force could not be controlled at its aim value and the error is growing with the feed movement. It means that, the model of the surroundings and the compliant wrist system could be used in force controlling when robots grind free-form surfaces of marine propellers with multi-point machining by a grinding wheel.

(3) The simulation results support that a Fuzzy-PID controller has preferable control performance than the conventional PID controller. Fuzzy is easy for computing and has the capability to satisfied control characteristics. The modelling, control and simulation of the Two-Phase Hybrid Stepping Motor have been done using the software package MATLAB/SIMULINK.

## References

- [1] Trygve Thomessen, Terje K Lien, Per K Sannås. Robot control system for grinding of large hydro power turbines. *Industrial Robot: An International Journal*. 2001; 28(4): 328-334.
- [2] Kunio Kashiwagi, Kozo Ono, Eiki Izumi, Tohru Kurenuma, Razuyoshi Yamada. Force controlled robot for grinding. *IEEE International Workshop on Intelligent Robots and Systems*. 1001-1006.
- [3] Paulo Abreu, Manuel Rodrigues Quintas. Pneumatic Driven Device for Integration into Robotic Finishing Applications. *Springer-Verlag Berlin Heidelberg*. 2013: 49-56.
- [4] Xu, Yangsheng. *Control Software of Robot Compliant Wrist System*. Technical Reports (CIS). Report number: 564. 1990
- [5] R Toscano. Robust synthesis of a PID controller by uncertain multimodel approach. *Information Sciences*. 2007; 177: 1441-1451.
- [6] D Puangdownreong, T Kulworawanichpong, S Sujitjorn. *Input weighting optimization for PID controllers based on the adaptive tabu search*. 2004 IEEE Region 10 Conference D. 2004: 451-454.
- [7] Sawsan Gharghory, Hanan Kamal. Modified PSO for Optimal Tuning of Fuzzy PID Controller. *IJCSI International Journal of Computer Science Issues*. 2013; 2(1): 462-471.
- [8] Yeqin, Wang. Direct drive electro-hydraulic servo control system design with self-tuning fuzzy PID controller. *TELKOMNIKA Indonesian Journal of Electrical Engineering*. 2013; 11(6): 3374-3382.
- [9] Qiujie Ma, Shi Jingzhuo. Fuzzy PID Speed Control of Two Phases Ultrasonic Motor. *TELKOMNIKA Indonesian Journal of Electrical Engineering*. 2014; 12(9): 6560-6565.
- [10] Manoj Kushwah, Prof Ashis Patra. Tuning PID Controller for Speed Control of DC Motor Using Soft Computing Techniques-A Review. *Advance in Electronic and Electric Engineering*. 2014; 4(2): 141-148.
- [11] ZC Li, B Lin, YS Xu, J Hu. Experimental studies on grinding forces and force ratio of the unsteady-state grinding technique. *Journal of Materials Processing Technology*. 2002; 129: 76-80.
- [12] Nguyen TD, Tseng KJ, Zhang, S, Nguyen HT. A Novel Axial Flux Permanent-Magnet Machine for Flywheel Energy Storage System Design and Analysis. *IEEE Transactions on Industrial Electronics*. 2011; 58(9): 3784-3794.
- [13] Zhang Tuanshan, Zhang Na, Wu Yuting. Study of driving bipolar stepper motors based on enhanced STM32. *Electronic Measurement Technology*. 2010; 33(10): 16-18.
- [14] Andrew J Blauch, Marc Bodson, John Chiasson. High-speed Parameter Estimation of Stepper. *Motors IEEE Transactions on control systems technology*. 1993; 1(4): 270-279.