

Gas-Liquid Chromatography: the Gas-Density Meter, a New Apparatus for the Detection of Vapours in Flowing Gas Streams

BY A. J. P. MARTIN AND A. T. JAMES

National Institute for Medical Research, Mill Hill, London, N.W. 7

(Received 7 November 1955)

The separation of volatile substances by gas-liquid chromatography (James & Martin, 1952; James, Martin & Smith, 1952; James, 1952; James & Martin, 1954; Ray, 1954*a, b*) requires that the substances be detected as they leave the chromatogram in the stream of gas that acts as the mobile phase of the system. A number of methods of detection of varying sensitivity have already been developed (James & Martin, 1952; Ray, 1954*a*; Griffiths, James & Phillips, 1952; Griffiths & Phillips, 1954), but we have felt it important to use a detector of high sensitivity whose response was independent of the chemical structure of the substances being separated.

From many points of view measurement of the density of the gas stream emerging from the chromatogram is attractive, since response is dependent on the molecular-weight differences of gas and vapour only, and calibration is relatively simple. Claesson (1946) has described an apparatus for comparing the density of a standard gas and that issuing from a chromatogram in which a liquid manometer is used to detect pressure differences between columns of gas 6 ft. long. The sensitivity of this apparatus suffices only for measuring the high concentrations encountered in displacement analysis. The pressure differences due to the flow of gas were kept very small by the use of large-diameter tubes; this resulted in the volume of the apparatus being very large.

In the design of an instrument based on the same principle (the gas-density meter) we have compensated for the pressure difference due to flow by employing tubes arranged as a bridge circuit in which two points can be found, vertically displaced from one another, where the pressure difference is independent of the rate of flow of gas. It is possible to combine two such bridges in one of which chromatogram gas flows and in the other a reference stream, so that the difference in head due to the density difference of the two gases is directly measurable.

The apparatus

The general arrangement is shown in Fig. 1. Gas from the chromatogram enters at *A*, divides upwards and downwards into two approximately

equal streams along *B* and *B'* and along the inclined channels *C* and *C'*, to combine again at *E* through channels *D* and *D'*. Reference gas enters at *F*, splits into two approximately equal streams along *G* and *G'*, then through channels *H*, *J*, *K* and *H'*, *J'*, *K'* and then combines with the chromatogram stream in *D* and *D'*, to emerge at the common outlet *E*.

The channels *D* and *D'* contain rods *N* and *N'*, one of which can be pushed into or withdrawn from the channel until the ratio of resistance to flow in channels *D* and *D'* is equal to the ratio of resistance to flow in channels *B*, *C* and *B'*, *C'*. The pressure difference between the points where *C* joins *D* and *C'* joins *D'* is then independent of the rate of flow of gas through *A*. Similarly, the channels *G* and *G'* contain two rods, one adjustable so that the ratio of resistance to flow in channels *G*, *H*, *J*, *K* and *G'*, *H'*, *J'*, *K'* can be matched against that in the first circuit. If the resistance to flow in *J'*, *K'* and *J*, *K* is the same, the pressure difference between the ends of the tube *L*, *L'*, which passes through the detector *M*, is independent of the rate of flow of gas through either *A* or *F*, and is in fact zero if the density of the gases entering at *A* and *F* is identical. If, however, the density of the gas entering at *A* is greater than that at *F*, the pressure at *L'* is less than that at *L* and a flow of gas through the detector

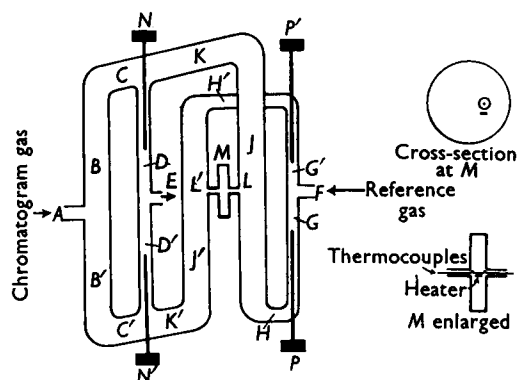

Fig. 1. Schematic diagram of the gas-density meter showing enlarged sections of the flow detector *M*. For details see text.

M takes place. Provided that all the velocities are low, the rate of flow of gas through L, L' will be proportional to the density difference.

It will be noticed that the channels C, K and C', K' are inclined to the horizontal; this is to ensure that when the gas entering at A is much heavier than that entering at F , it will form a stable layer at the entrance to D and D' and there will be no tendency for heavy gas to spill over into J , or light gas into B' .

The channels D, D' and G, G' are of relatively small diameter so that the flow through them is practically unaffected by the pressure changes due to the differences in density. The apparatus has been designed to have the greatest possible symmetry, so that any transient changes of pressure shall cause no flow through L, L' , and so that, if the resistance to the flow of gas includes factors due to velocity as well as to viscosity, the ratio of resistance shall be affected only to a second order by a change in the rate of flow.

The detector consists of a disk-shaped cavity M (Fig. 1) with a horizontal axis which lies midway between the tubes J' and J and is connected to them by the tube L, L' , whose axis is parallel to, but displaced horizontally from, the disk axis. Along the axis of the tube L, L' is strung a pair of thermocouples of constantan and copper, the junctions of which lie approximately in the planes of the sides of the disk. Beneath the central constantan section is a small Nichrome heater; a stream of hot convected gas circulates from this within the disk. The thermocouples and heater are placed so that when no gases pass through the tube L, L' the junctions of the thermocouples are heated to the same temperature. A flow of gas through this tube causes a displacement of the hot convected stream, so that the junction at the side at which the gas enters becomes cooler and that at the side at which it leaves becomes hotter. The output of the thermocouples thus provides a measure of the direction and velocity of the gas flow and therefore of the density difference of the chromatogram and reference-gas streams.

As only reference gas passes through L, L' no pyrolysis of vapours from the chromatogram can occur, and the heater and thermocouple need not be chemically resistant to the substances separated by the column.

The details of the apparatus are described in the Experimental section.

Sensitivity

The sensitivity of the apparatus is clearly dependent on the lengths of the columns whose density is being compared. It can easily be shown that to obtain maximum velocity along the line of the thermocouple the ratio of length to the fourth

power of the diameter of L, L' should be equal to the ratio of the length of the main channels BB', CC', KK' and J to the fourth power of their common diameter, and that, other things being equal, the velocity is proportional to the cross-sectional area of the tubes. It is therefore probable that the sensitivity of the apparatus varies directly with the volume of the main channel, though this has not been experimentally verified.

The sensitivity of the detector depends obviously on the power dissipated by the heater since the slope of the thermal gradient will increase with heater output. The temperature gradient along the thermocouple is reduced by conduction of heat along the wire itself, and hence the thinner the wire the more sensitive it will be. The optimum length of the centre constantan portion of the thermocouple was found experimentally to be approximately the width of the cavity.

The nature of the gas filling the detector was found to affect greatly the sensitivity of the instrument. Thus the sensitivity in hydrogen was of an order of magnitude less than that in nitrogen, presumably because the higher thermal conductivity of hydrogen reduced the temperature gradient and the smaller density reduced the part played by convection in the cavity. The importance of this convection was shown by the fact that inversion of the apparatus, which causes the convection stream to be directed away from instead of towards the thermocouple, reduced the sensitivity to about a quarter of its former value. Using nitrogen as the carrier gas, we have been able to detect 1 molecule of pentanol in 10000 molecules of nitrogen.

Stability

The sensitivity of the apparatus can always be increased by increasing the amplification of the thermocouple output, but a limit is set to useful amplification by the zero stability. With this apparatus a difference in temperature of 0.001° between the principal channels is all that can be tolerated; hence the whole apparatus is constructed from a solid block of copper immersed in the vapour of the pure liquid used to provide the vapour jacket for the chromatogram. The sensitivity of the zero to temperature fluctuations depends on the density of the reference gas, and hydrogen should therefore be the best carrier gas, provided that adequate amplification is available. With the amplifier we have used (Sunvic amplifier) it is preferable to use nitrogen. A limit is set to the rate of flow of gas through the apparatus by the onset of turbulence, probably at the ends of the adjusting rods. This turbulence begins suddenly at a particular rate of flow which is in fact higher than any we have found convenient with our small chromatograms. For very large columns it would be sufficient to

The channels *BC*, *J* and *K* (Figs. 4, 5) are all $\frac{3}{8}$ in. in diameter, and *A*, *D*, *E*, *F*, *G*, *H*, are $\frac{1}{8}$ in. in diameter. Where the columns are let into the block (Fig. 5) the diameter of *A* is increased to $\frac{5}{8}$ in. in diameter. The tubes *L*, *L'* (Fig. 4*B*) are $\frac{3}{8}$ in. in diameter, though the subsequent work has shown that this can be increased to $\frac{1}{2}$ in. with advantage. The cavity *M* is 1 in. in diameter and $\frac{1}{8}$ in. thick.

The thermocouples are constructed of 50 s.w.g. (0.001 in.) copper and constantan which have been welded electrically. In the original model the outer case was constructed of brass, but we now recommend that copper be used.

It is desirable that the whole apparatus should be hard-soldered; this has proved a difficult operation, and the most satisfactory method appears to be to silver-plate the surfaces to be united with approximately 0.00025 in. of silver and then to heat the whole in an atmosphere of hydrogen at 850° for a few minutes. (We are indebted to Dr Ivor Jenkins of the G.E.C. Research Laboratories for informing us of this technique.) The block must be gas-tight, and this may be tested by blowing it up to a pressure of an atmosphere or two and painting the outside with Teepol (Shell Chemicals Ltd.). The thermocouples are strung through glass capillary tubes which have been ground to fit into a conical hole in a shouldered copper plug (Fig. 6*A*) which is held in the block by a screwed outer sleeve, gas-tightness being ensured by a lead washer between the sleeve and the plug. The glass capillary is cemented to the copper plug with Araldite cement (Aero

Research Ltd., Duxford, Cambridge). At the other end of the capillary a copper cap terminates in a small tube of $\frac{1}{8}$ in. outside diameter and drilled with a no. 80 drill. The thermocouple is mounted in the following way: the completed assembly of copper plugs and capillary tubes and outer sleeves are threaded with a double loop of 50 s.w.g. constantan wire and are assembled into the block with the wire threaded through the tubes *L*, *L'*. The block is then placed so that the capillaries are vertical, and the thermocouple is now drawn roughly into position by means of the loop. The upper end of the thermocouple is attached to some device that can be moved slowly and steadily, and a weight of 3 g. is carefully attached to the other end. By the use of a microscope illuminated through the eyepiece and with a 2 in. objective, the thermocouple is adjusted to be symmetrically placed inside the cavity *M*. The end of the tube protruding from the copper cap (Fig. 6*A*) at the end of the upper glass capillary is now pinched flat by a pair of small pliers; this fixes the thermocouple in place and provides a gas-tight seal. The lower cap is then similarly treated and the thermocouple is thus left taut. Electrical contact to these end caps is made by copper clips. By avoiding the use of any metal but copper the only parasitic thermoelectric potentials that one has to fear are the very small ones between annealed and cold-worked copper.

The heater insert (Fig. 6*B*) is constructed from brass and contains a thin-walled glass capillary tube through which passes an 18 s.w.g. copper wire, hard-soldered at the outer end to a copper plug $\frac{1}{8}$ in. in diameter (i), the wire being

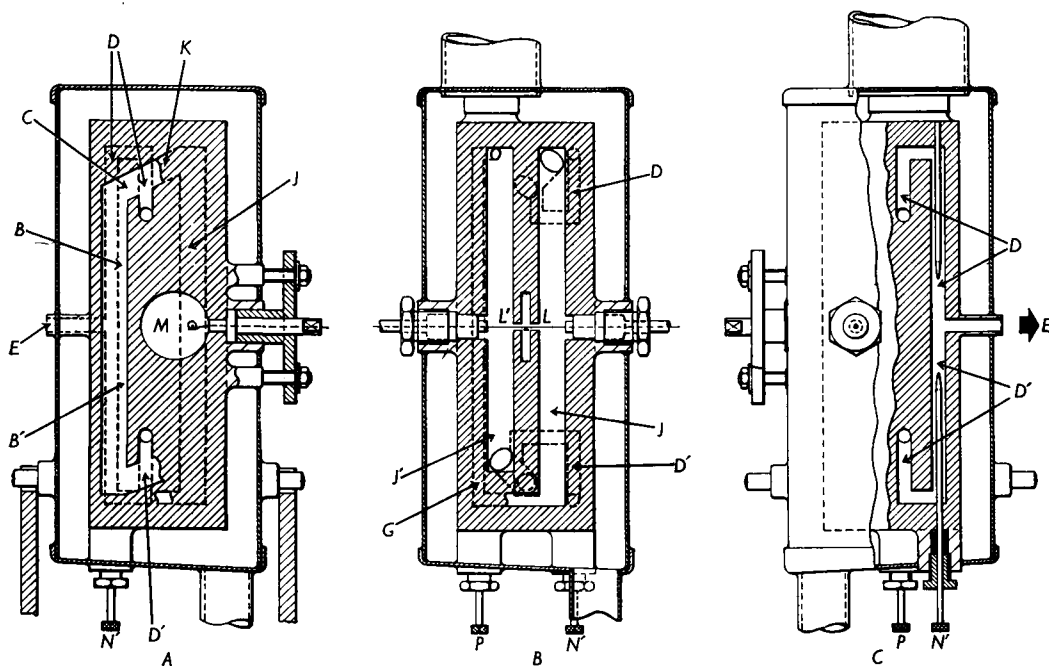

Fig. 4. (A) Section of gas-density meter along the line 2-2 from Fig. 3*A*, showing the position of the channels *BB'*, *C*, *D*, *K*, *J* and *D'*, the adjustable compensating rod *N'*, and the support trunnions. (B) Section of gas-density meter along the line 4-4 from Fig. 3*A*, showing the channels *J*, *J'*, *G*, *D'* and *D* and the adjustable compensating rods *P* and *N'*. (C) Part section of the gas-density meter along 3 from Fig. 3*A*, showing the exit channel *E* and the fixed and adjustable compensating rods in channel *DD'*.

cemented in place with Araldite. A short piece of 18 s.w.g. copper (ii) is hard-soldered to the inner end of the heater insert. The heater proper (iii), a hairpin of 30 s.w.g. Nichrome $\frac{1}{2}$ in. long, is hard-soldered to the two 18 s.w.g. wires. The electrical supply to the heater is connected by a clip to the plug protruding from the outer end of the heater insert and to the case of the block. A current of 2-3A is sufficient to raise the heater temperature to 600-800°. The sensitivity of the apparatus depends on the energy dissipated in the heater, but a baretter (constant-current regulator, Tungram BR 300-0 C) in series with the transformer supplying the current has been found to give adequate constancy of output. The Nichrome wire heater lies parallel to and below the axis of the insert, so that a slight degree of lateral adjustment is possible by rotating the insert, which is provided with a hexagon at its outer end

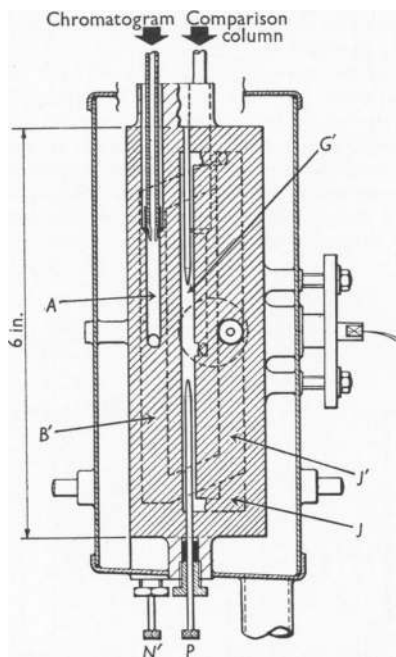

Fig. 5. Section of gas-density meter along the line 1-1 from Fig. 3A, showing a column and gasket inserted in the block and the fixed and adjustable compensating rods.

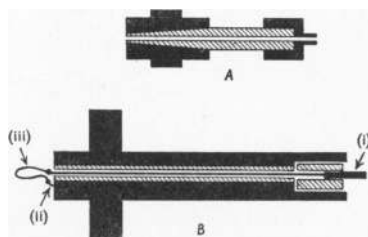

Fig. 6. (A) Cross-section of one of the thermocouple supports. (B) Cross-section of the heater insert. (i) Copper plug; (ii) copper wire; (iii) heater wire.

to allow its adjustment by a spanner. The insert is held in place by a sleeve with a cross-head passing over two bolts fixed to the block. Gas-tightness of the insert is ensured by the presence of lead washers beneath the sleeve.

The case, separated from the block by a gap of $\frac{1}{4}$ in., is hard-soldered to the bosses protruding from the block. The bottom of the case is sloped, so that a pool of liquid cannot collect and so contaminate a new solvent introduced into the boiler when the operating temperature is changed.

The two chromatographic columns are housed in a double-walled tube, the inner member of which is soldered to the top of the block and the outer member to the case. A condenser is connected to the top of this vapour jacket (Fig. 7), and the condensate returns to the boiler through a U-trapped tube. This trap prevents circulation of the cold air from the condenser into the main vapour stream. The trap is provided with a drain cock for use when the liquid in the boiler is changed. The double-walled tube has two staggered joints (Fig. 7) in the inner and outer tubes; the inner one projects 3 in. farther from the block than the outer one, and this permits the long tubes to be soldered independently.

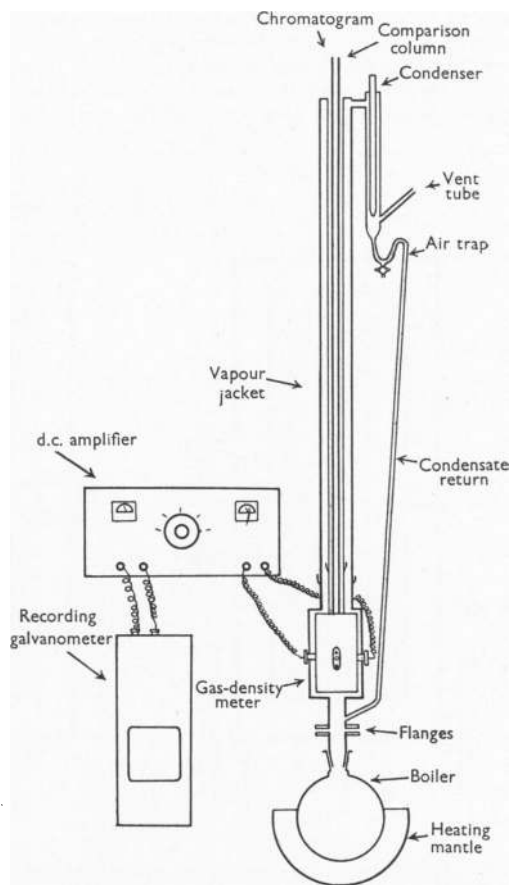

Fig. 7. Schematic diagram of gas-liquid chromatographic apparatus in which the gas-density meter is used as the detector.

A 1 in. diameter tube is attached to the bottom of the case which has at its lower end a flange $2\frac{1}{4}$ in. in diameter; the condensate from the condenser enters its side above this flange (Fig. 7). A standard glass cone (B24) flanged at its upper end is held against the brass flange by three screws passing through a brass ring. An asbestos ring is provided on either side of the glass flange to prevent cracking when the holding screws are tightened.

The boiler consists of a 1 l. round-bottomed glass flask with a standard taper neck (B24) held in an electric heating mantle by means of three springs. The whole apparatus is supported in a frame by two trunnions; these project from the walls of the case (Fig. 4A) along an axis at right angles to the line of the thermocouples, which rest in two fixed V supports. The top of the column vapour jacket is clamped to a screw-operated slide, so that by movement of the screw the entire apparatus can be tilted on the trunnions.

The leads from the thermocouples are connected to a Sunvic d.c. amplifier (DC AI-MK II, Sunvic Controls Ltd., London, W.C. 2) giving an output of 5 mA for a 100 μ V input; a switch on the instrument is available to reduce the sensitivity by factors of 10, 100 or 1000. The output of the amplifier goes to a 5 mA recording galvanometer (Murday type, Evershed and Vignoles Ltd., Acton Lane Works, Chiswick, London, W. 4).

Setting up the apparatus

Two columns are packed with identical material using a high-boiling stationary phase (see James & Martin, 1952), fitted with valve-rubber gaskets for working temperatures up to 137° (above this temperature silicone rubber should be used), passed into the vapour jacket and into the holes in the block. It is convenient to start the apparatus at 100° with water in the boiler and to allow time for temperature equilibration. Nitrogen from the manostat (James & Martin, 1952) is permitted to pass down both columns, with an excess pressure of approximately 1 atm. This should be allowed to continue for an hour or two to remove low-boiling impurities from the columns and the block, and to remove occluded material from the rubber-tubing connections. Unless this initial cleaning-up procedure is adopted it is impossible to obtain proper stability and proper adjustment of the apparatus. The flow of gas in both columns is then stopped, and the heater insert is slackened and rotated until the thermocouple output is as close as possible to zero; the heater insert is then retightened. The thermocouple output is then adjusted to zero by tilting the apparatus with the slide. Gas is then allowed to flow through the chromatogram tube alone and the adjusting rod *N* is moved after slackening the gland nut until the instrument is again balanced, when the gland nut is retightened. On again cutting off the flow of gas the instrument should still be in balance; if not, the flushing-out period was insufficient. Gas is now admitted to both columns and the adjusting

rod *P* (Fig. 4B) is moved, after its gland nut has been slackened, until balance is reattained. The apparatus should now be in sufficient balance over all possible rates of flow in either column for complete balance to be obtainable by the use of the fine adjustment given by tilting the apparatus. At very high rates of flow true balancing becomes impossible, and the adjusting rods may have to be reset for these special conditions. If it proves impossible to balance the apparatus, leakage at some point is indicated. The application of jet of compressed air to the plugs on the block will soon reveal this leakage point unless this is from the heating jacket to the inside of the block (this should be tested before the case is put on). Once this complete procedure has been followed, a change of columns or of temperature should make only a small alteration to the zero of the instrument, which can be corrected by adjustment of the slide tilting the apparatus.

Occasionally on changing the boiler liquid a cyclic fluctuation of the zero may be seen; this is due to insufficient removal of the more volatile impurities in the liquid, causing a fluctuation of the temperature of the block as the more volatile liquid runs back to the boiler. Drawing liquid from the trap beneath the condenser for a few minutes is usually sufficient to cure the trouble.

Examples of the use of this apparatus can be seen in the next paper, and in papers by James (1955*a*, *b*).

SUMMARY

1. A highly sensitive detector of vapours in gas streams, suitable for use with the gas-liquid chromatogram, is described.

We should like to thank Mr R. Bowers and Mr D. G. Childs for help in the construction of the apparatus, and Mr C. Couling for some of the drawings.

REFERENCES

- Claesson, S. (1946). *Ark. Kemi Min. Geol.* **23**A, no. 1.
 Griffiths, J. H., James, D. H. & Phillips, C. S. G. (1952). *Analyst*, **77**, 897.
 Griffiths, J. H. & Phillips, C. S. G. (1954). *J. chem. Soc.* p. 446.
 James, A. T. (1952). *Biochem. J.* **52**, 242.
 James, A. T. (1955*a*). *Research, Lond.*, **8**, 8.
 James, A. T. (1955*b*). *Mfg Chem.* **26**, 5.
 James, A. T. & Martin, A. J. P. (1952). *Biochem. J.* **50**, 679.
 James, A. T. & Martin, A. J. P. (1954). *Brit. med. Bull.* **10**, 170.
 James, A. T., Martin, A. J. P. & Smith, G. H. (1952). *Biochem. J.* **52**, 238.
 Ray, N. H. (1954*a*). *J. appl. Chem.* **4**, 21.
 Ray, N. H. (1954*b*). *J. appl. Chem.* **4**, 82.