

Gas-liquid Partition Chromatography: The Separation and Micro-estimation of Ammonia and the Methylamines

By A. T. JAMES, A. J. P. MARTIN

National Institute for Medical Research, Mill Hill, London, N.W. 7

AND G. HOWARD SMITH*

Low Temperature Research Station, University of Cambridge

(Received 15 November 1951)

The quantitative micro-analysis of a mixture of ammonia and the methylamines is difficult. A number of colorimetric and other methods exist for the estimation of individual amines, but until recently the only comprehensive scheme (Reay, 1937) depended on the separate analysis of several portions of the mixture after selective precipitation or destruction of one or more of the components—a rather lengthy procedure. Partition chromatography is a promising technique for such a problem and has been used by Fuks & Rappoport (1948) with *n*-butanol-water as the phase pair, on a column of starch mixed with calcium hydroxide. The amines were run as the free bases and were estimated by continuous titration of the effluent from the column. The four amines could be separated from one another but some losses by volatilization occurred during application of the bases to the column. Lagerkvist (1950) separated ammonia and methylamine on a starch column with *n*-propanol-aqueous hydrochloric acid as the solvent system, the positions of the zones being determined by treatment of the eluate with ninhydrin. The recoveries obtained were not stated.

The success which attended the use of gas-liquid partition chromatography in the quantitative micro-analysis of the volatile fatty acids (James & Martin, 1952) suggested its application to the analysis of mixtures of volatile bases. A procedure for the separation of ammonia, methylamine, dimethylamine and trimethylamine is given here; the application of the method to the separation of other aliphatic and of cyclic bases is described in the following paper (James, 1952).

By use of the same general technique as described for the fatty acids, ammonia and the three methylamines may be separated on kieselguhr columns containing a mixture of hendecanol (5-ethylnonan-2-ol) and liquid paraffin as the liquid phase, at a temperature of 78.6°, with only a very slight overlap of the zones of the three methylamines (Fig. 4). The amines emerge from the column in the order of their

boiling points (ammonia -33.4°, methylamine -6.5°, trimethylamine 3.5°, dimethylamine 7.4°). It was found that the kieselguhr used as the support for the liquid phase was not inert and adsorbed the amines producing a tail on each zone. Pretreatment of the kieselguhr with methanolic sodium hydroxide prevented most of this adsorption, though enough still occurred to make the zones markedly asymmetric (Fig. 4, curve *B*). No means of overcoming this residual adsorption has yet been found.

The corrected retention volume (V_R^0 as defined by James & Martin, 1952) is a measure of the free energy of association between solute and the liquid phase, both hydrogen bonding and van der Waals forces contributing to this energy of association. The van der Waals forces increase with the number of *N*-methyl groups but each successive group contributes less; the hydrogen-bonding forces vary in a way which in detail is unpredictable. A rough estimate of the van der Waals forces can be obtained from the behaviour of the methylamines on a column having liquid paraffin as the stationary phase, no hydrogen bonding with this solvent being possible (Table 1). The relative hydrogen-bonding power of the methylamines might be expected to run parallel with the order of their basic strengths (dimethyl > methyl > trimethyl > ammonia). Where hydrogen-bonding is possible between solute and solvent (e.g. hendecanol) the order expected from the hydrogen-bonding is different from that expected from van der Waals forces (trimethyl > dimethyl > methyl). The actual order in which the amines will emerge from a column will depend on the relative contributions of the two forces. The factors governing the boiling point sequence are the same as those governing retention-volume sequence in so far as the pure amine constitutes a solvent of properties similar to the liquid phase used on the column. The retention volume of the trimethylamine in a solvent containing hydroxyl groups is greater than would be expected from the boiling point, since hydrogen bonding between the nitrogen atoms in the pure amine is not possible. With hendecanol or hendecanol-15% (v/v) liquid paraffin as the liquid phase,

* Present address: Biochemical Laboratory, University of Cambridge.

hydrogen bonding is important and the amines emerge in the order of the boiling points. When the hendecanol content is reduced (e.g. to 50% hendecanol-liquid paraffin) the amount of hydrogen bonding is decreased and the van der Waals forces exert a greater effect on zone order. The trimethylamine zone now coincides with the dimethylamine zone (Fig. 5, curve A). With a liquid phase of paraffin alone the trimethylamine zone comes after the dimethylamine zone, but the difference is insufficient to allow a useful separation on a 4 ft. column (see Table 1), possibly because of the relatively greater adsorption of dimethylamine on the kieselguhr.

In a more polar solvent such as glycerol, the bonding energy between the glycerol molecules is greater than that existing between the glycerol and

investigated and the results of Cromwell (1950) have been confirmed, only ammonia and trimethylamine being found (Fig. 6).

EXPERIMENTAL

Preparation of the columns. Celite 545 was size graded, ignited and acid-washed as described by James & Martin (1952). Before use it was treated with 5% (w/v) methanolic NaOH, decanted and the wet kieselguhr oven-dried at 100°. It was stored in a desiccator over solid NaOH. The liquids used as stationary phases were the following: hendecanol (5-ethylnonan-2-ol, supplied by General Metallurgical and Chemical Ltd., 120 Moorgate, London, E.C. 2), liquid paraffin B.P., DC 550 silicone (Midland Silicones Ltd.) and glycerol. The liquid phase was added to the kieselguhr in the ratio of 3 g. of liquid phase to 7 g. of kieselguhr and the two thoroughly mixed and packed into a 4 ft. 4 mm.-internal-

Table 1. *Relative retention volumes of the methylamines*

(Volumes are relative to that of NH_3 , taken as 1.)

Liquid phase (% v/v)	CH_3NH_2	$(\text{CH}_3)_2\text{N}$	$(\text{CH}_3)_3\text{NH}$	Temp. (°)
Hendecanol	3.4	4.2	5.2	78.6
Hendecanol-15% liquid paraffin	3.6	4.6	5.8	78.6
Hendecanol-50% liquid paraffin	4.2	7.5	7.5	65
Liquid paraffin-33% hendecanol	3.8	6.8	6.8	65
Liquid paraffin	1.65	2.7	2.7	78.6
Glycerol	2.5	0.47	Approx. 1	100
Silicone DC550-10% hendecanol	1.33	0.36	0.78	65

Table 2. *Conditions recommended for chromatography of amine mixtures*

Amine mixture	Liquid phase	Temp. (°)
Ammonia, mono-, di- and tri-methylamines	Hendecanol-15% (v/v) liquid paraffin	78.6
Ammonia, mono- and di-methylamines }	Hendecanol-50% liquid paraffin	78.6
Ammonia, mono- and tri-methylamines }	Hendecanol	78.6
Ammonia, di- and tri-methylamines	Glycerol or silicone DC550-10% hendecanol	100
Mono-, di- and tri-methylamines		65

amine molecules, the effect being analogous to a high internal pressure forcing out the molecules of higher mol. wt. The order of emergence with a liquid phase of glycerol is thus trimethylamine, dimethylamine, methylamine (Fig. 5, curve B). Unfortunately, the effect does not delay the emergence of the ammonia zone enough to prevent it overlapping the dimethylamine zone; presumably this is due to the low basic strength of ammonia. Such a column is therefore useless for resolution of all four bases. A similar effect is observed with a liquid phase consisting of DC 550 silicone-10% hendecanol (Table 1).

Where mixtures of only three of the four amines are encountered, advantage can be taken of particular liquid phases. Table 2 shows those recommended for different amine mixtures. As a test of the method the amines occurring free in *Chenopodium vulvaria* L. (stinking goosefoot) have been

diameter column of the type described by James & Martin (1952). The column efficiencies are of the order of 650 plates, under the conditions of flow rate and temperature shown in Fig. 4.

Burettes. The apparatus used was that described by James & Martin (1952), the titrations being carried out automatically with 0.04N- H_2SO_4 using 0.007% (w/v) aqueous methyl red solution in the titration cell. Whilst the recording burette is a great convenience, any burette capable of delivering known constant volumes gives perfectly satisfactory results. The titration is then carried out by supplying to the titration cell a certain amount of acid, the time required for its neutralization is noted and a further addition of the same amount of acid is made. (More dilute indicator solution is preferable with this method.) This proves to be easier than reading the burette at constant time intervals. A curve of total acid delivered against time is plotted, the height of each step giving the amount of each component. Three types of suitable burette are illustrated in Figs. 1-3. The first (Fig. 1a) consists simply of a small

Erlenmeyer flask, containing the acid, fitted with an inlet and outlet tube. By squeezing the rubber tube fitted to the inlet a drop of acid can be formed on the outlet tube and any number of these drops can be rapidly delivered to the titration cell. The drop size is constant and can be calibrated; the number of drops added to the titration cell to keep the solution near the end point can readily be followed.

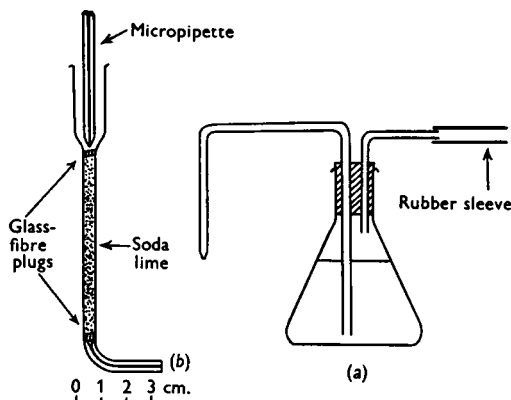

Fig. 1. (a) Dropping burette. (b) Microcolumn for liberation of the amines from solutions of their salts.

The second (Fig. 2) uses a screw passing through a nut and a cork gland kept in place by sealing wax at the end of the burette. As the screw is rotated by the handle it passes into the burette and the acid is displaced into the titration cell. By counting the number of turns of the screw the total amount of acid delivered is readily ascertained. As glass taps have been found to be unserviceable for long periods because of leakage, the rubber-glass rod valves described by James & Martin (1952) are used. The burette is readily filled

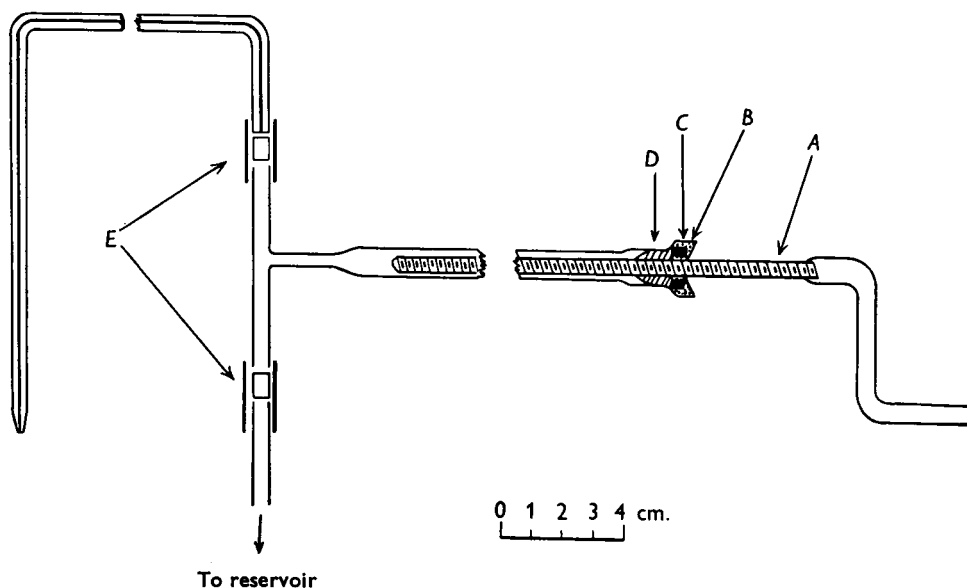

Fig. 2. Screw burette. A, screw (2 BA thread); B, sealing wax; C, nut; D, cork; E, valves.

by closing the valve leading to the cell and opening the one leading to the acid reservoir, and winding back the screw.

The burette illustrated in Fig. 3 is one which uses the micrometer from an 'Agla' microsyringe (Burroughs Wellcome Ltd.). This type of burette is only suitable when

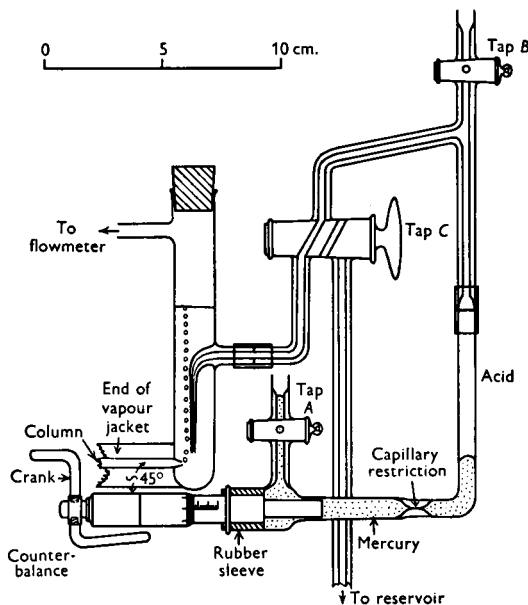

Fig. 3. Micrometer burette and titration cell.

there is a long time interval between the emergence of successive zones. The end of the micrometer barrel is held firmly in the glass tubing by a rubber sleeve. Rotation of the micrometer displaces mercury which in turn forces acid into

the titration cell. The taps *A* and *B* are not essential, but enable the initial filling of the burette and removal of air to be performed more easily. The mercury is then adjusted to a suitable level by manipulation of tap *A*. Tap *C* could perhaps be replaced with advantage by the rubber-glass rod valves previously described. The moving scale on the micrometer is divided into hundredths, and can be estimated to one-tenth of a division; with 0.1*N*-acid in the burette, a noticeable change in colour of the indicator is observed for a movement of one- or two-hundredths of a rotation. The scale remains in an almost constant position beneath the titration cell, so that the two may be watched simultaneously

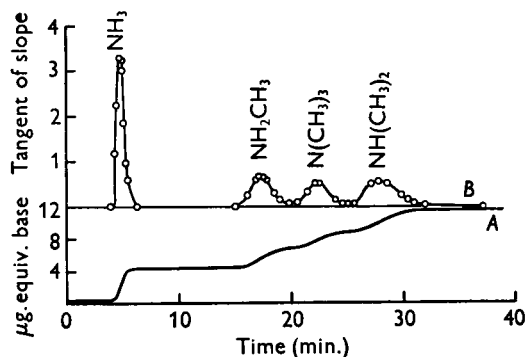

Fig. 4. The separation of ammonia, mono-, tri- and dimethylamines. Curve *A*: experimental curve; curve *B*: curve obtained by graphical differentiation of experimental curve, showing slight tailing of zones. Column length, 4 ft.; liquid phase, hendecanol-15% liquid paraffin (v/v); temp., 78.6°; flow rate of nitrogen, 5 ml./min.; nitrogen pressure, 65 mm. Hg.

and readings taken every half min. It is more convenient to operate the burette with the left hand in order to have the right free for recording the results, though the scale marked on the micrometer is then inverted. The burette is filled by reversing tap *C* and winding back the micrometer.

Liberation of the free bases from the amine salts. Application of the free amine bases in aqueous solution to the column leads to bad separations and so the following technique has been devised.

A small vertical column terminating in a short horizontal capillary (Fig. 1*b*) is filled with dry soda lime (50 mesh) and a very small plug of glass fibre packed on top of the filling. This extraction column is attached by a piece of pressure tubing to the chromatogram held in the vapour jacket, the dead space at the end of the chromatogram tube being filled by a suitable length of loosely fitting glass rod. Approx. 0.8*N* solution (total amines) (0.05 ml.) of the amine salts is run on to the column by placing the micropipette on the glass-fibre plug. When the extraction column has taken up the solution, the plug is washed with two lots of 0.025 ml. of distilled water, the N_2 supply is connected and the gas stream started. The wet part of the column is warmed with a microburner until the visible water front has moved almost to the bottom of the column, the whole tube then being hot. The indicator solution is run into the cell and the titration carried out as usual. The recoveries are approximately theoretical, the reproducibility being $\pm 4\%$.

Operation of the chromatogram and results. The amines were applied to the chromatograms either as solutions of the free bases in ethanol (3 μ l. of a 20% solution) or by means of the technique outlined above, starting from a solution of the amine salts.

The four amines were applied singly and in mixtures to the chromatograms. The retention volume of each zone was measured and corrected to zero pressure difference across the column (V_E^0) by the use of the graphs of the relationship between P_1/P_0 and V_E/V_E^0 given by James & Martin (1952).

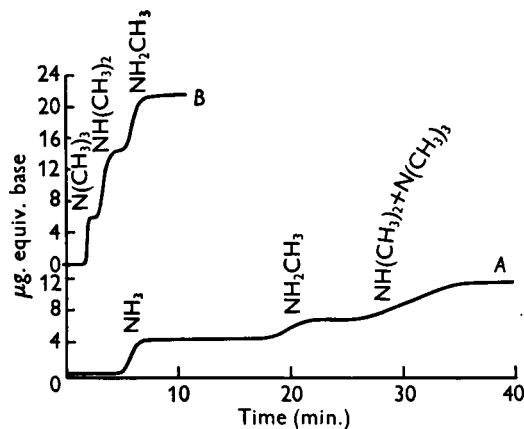

Fig. 5. Curve *A*: the separation of ammonia and the methylamines showing coincidence of trimethylamine and dimethylamine zones on increasing the paraffin content of the hendecanol to 50%. (Column length, 4 ft.; liquid phase, hendecanol-50% liquid paraffin (v/v); temp., 78.6°; flow rate of nitrogen, 3.6 ml./min.; nitrogen pressure, 65 mm. Hg.) Curve *B*: the separation of the methylamines showing the effect of a liquid phase having high internal pressure (glycerol). The amines now appear in order of decreasing molecular weight. (Column length, 4 ft.; liquid phase, glycerol; temp., 100°; flow rate of nitrogen, 4 ml./min.; nitrogen pressure, 60 mm. Hg.)

The corrected retention volumes of NH_3 on each type of column used are shown in Table 3. The solvents used in the vapour jacket to give the temperatures quoted are methanol (65°), ethanol (78.6°) and water (100°). Typical analyses of mixed amines are shown in Figs. 4 and 5.

Table 3. Corrected retention volumes of NH_3 with various liquid phases

Liquid phase (v/v)	Temp. (°)	V_E^0 (ml.)*
Hendecanol	78.6	37.4
Hendecanol-15% liquid paraffin	78.6	23.2
Liquid paraffin-50% hendecanol	65	24.1
Liquid paraffin-33% hendecanol	65	21.0
Liquid paraffin	78.6	8.2
Glycerol	100	15.0
Silicone DC 550-10% hendecanol	65	21.0

* Defined by James & Martin (1952).

The burette illustrated in Fig. 3 was used with columns run at room temperature, when of course the time taken was much longer than that shown in Fig. 4. The efficiency of the

column under these circumstances is lower (cf. James & Martin, 1952), but is adequate to separate any three of the four amines provided a suitable liquid phase is chosen (Table 3).

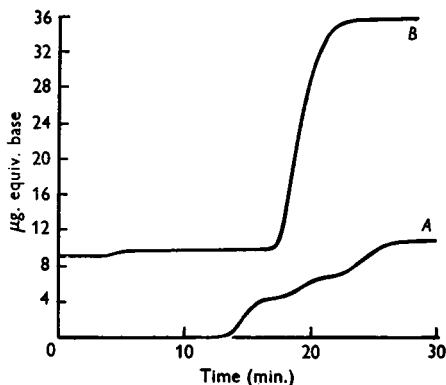

Fig. 6. Analysis of the volatile amines present in *Chenopodium vulvaria* L. Curve A: standard mixture of mono-, di- and tri-methylamines. Curve B: chromatogram of the amines present in an acid extract of the plant, showing the presence of only ammonia and trimethylamine. (Column length, 4 ft.; liquid phase, hendecanol-15% liquid paraffin (v/v); temp., 78.5°; flow rate of nitrogen, 5.7 ml./min.; nitrogen pressure, 80 mm. Hg.)

The lower limit of quantity of amine that can be detected with this technique is 0.3 µg. equiv., i.e. 2 µg. of NH₃, 4 µg. of monomethylamine, 7 µg. of dimethylamine and 8 µg. of trimethylamine. The maximum amounts of amines that still allow good separations are 160 µg. of NH₃, 180 µg. of monomethylamine, 180 µg. of dimethylamine and 220 µg. of

trimethylamine, using a 4 ft. 4 mm. internal-diameter column.

The estimation of the amines present in *Chenopodium vulvaria* L. The leaves from four plants of *C. vulvaria* L. (approx. 100 g.) were minced in a Waring Blendor and extracted with 0.001N-HCl (1 l.). The extract was filtered, centrifuged and then made alkaline with NaOH. Air was drawn through the mixture into a wash bottle containing 0.001N-HCl. At the end of an hour the wash bottle was removed and its contents evaporated almost to dryness. The solution was made up to 2 ml., and 0.1 ml. portions were taken for analysis. The results are shown in Fig. 6.

SUMMARY

1. A technique for the micro-estimation and separation of ammonia and the three methylamines is described.
2. Some factors influencing the relative positions of amines on gas-liquid partition chromatograms are discussed.
3. A method of applying the amines to the columns starting from a solution of the amine salts is described.
4. All the curves illustrated have been obtained by the use of the automatic recording burette described by James & Martin (1952). Three types of manual microburette are now described, together with appropriate titration procedures.

Our thanks are due to Dr B. T. Cromwell for the gift of the stinking goosefoot. Part of this work (by G.H.S.) was carried out as part of the programme of the Food Investigation Organization of the Department of Scientific and Industrial Research.

REFERENCES

- Cromwell, B. T. (1950). *Biochem. J.* **46**, 578.
 Fuks, N. A. & Rappoport, M. A. (1948). *C.R. Acad. Sci. U.R.S.S.* **60**, no. 7, 1219.
 James, A. T. (1952). *Biochem. J.* **52**, 242.
 James, A. T. & Martin, A. J. P. (1952). *Biochem. J.* **50**, 679.
 Lagerkvist, U. (1950). *Acta chem. scand.* **4**, 543.
 Reay, G. A. (1937). *Rep. Food Invest. Bd., Lond.*, p. 69.

Gas-liquid Partition Chromatography: the Separation of Volatile Aliphatic Amines and of the Homologues of Pyridine

By A. T. JAMES

National Institute for Medical Research, Mill Hill, London, N.W. 7

(Received 1 January 1952)

Previous papers (James & Martin, 1952; James, Martin & Howard Smith, 1952) have described the separation of volatile fatty acids and also of ammonia and the methylamines by means of gas-liquid partition chromatography. This study has now been extended to include higher aliphatic amines and pyridine homologues.

Aliphatic amines

By the use of columns having liquid paraffin as the stationary phase a great many primary, secondary and tertiary aliphatic amines may readily be separated from one another in amounts between 0.3 and 10 µg. equiv. In Fig. 1, curve A shows the