

# General Discussion on Dimming Control Method Used for Discharge Lamp

P. Dong, K. W. E. Cheng, S. L. Ho, D. H. Wang, B. P. Divakar, and K. Ding  
Power Electronics Research Centre  
Department of Electrical Engineering  
The Hong Kong Polytechnic University

**Abstract**— In order to reduce the energy, the dimming control is used in the lighting system. There are many different control methods in the fluorescent lamp, after comparing these methods, a research scheme of dimming control used in the HID ballast is proposed. In addition, the lamp model, dimming range and stability analysis are also analyzed in this paper.

**Index Terms**—Discharge Lamps, Dimming Control, Dimming Range, Stability Scope

## I. INTRODUCTION

HID lamp becomes more popular with high lumen/watt ratio and the good rendering factor that affects the color of the light. In addition, dimming is a good method to save energy when intensity of the light may not be important or can be adjusted over a day. The advantages of dimming also include the enhanced flexibility for multi-use spaces and reduced in peak power demand [1, 2].

In addition, good light vision is very important to the driver. But in practice it is found that quite wide variations of brightness do not seem to matter to human's eye and, unless the difference in readings is more than 50% the eye hardly notices any difference in brightness. The eye needs quite big changes in light level to notice a real difference. In practice the effect of any dimming is also dependent on field of view, the color concerned, and, when multiple sources are being used, the interaction of such sources. So if the dimming light meets the need of the international standard, the dimming control also can be used in the xenon headlight system.

There are many different dimming control methods used in the world. In order to realize the dimming control, the first step is to establish the lamp model. Then the dimming control algorithm based on the lamp model will be given. At last, the dimming effect will be verified and the dimming range, system stability analysis will be done. In this paper, the lamp model which will be used in the dimming control is presented. After giving the different control methods, the dimming range and stability analysis are also analyzed.

## II. LAMP MODEL

Much effort has been devoted to the development of sophisticated high intensity discharge lamp models by

researchers. According to the physical phenomenon, Waymouth and Elenbaas established the HID model [3].

But the parameters in the model are complicated and difficult to get and use. Deng used the small signal method in the Fluorescent field [4].

Wei and Liu modulated the model of HID and Fluorescent into the software PSpice [5, 6]. However, for a ballast circuit designer, the most interesting characteristic of a lamp is its terminal characteristic as an electrical load. Therefore, a simplified lamp model is needed as a CAD lamp model. This model should be simple and user-friendly but can also reveal important physical trends in a lamp for a wide range of operating frequency.

Laskowski [7] had done some research work about the terminal V-I behavior of the lamp and others also used staged function to fit the V-I curve [2].

But the values of lamp voltage and current are affected by the temperature, a simple V-I curve cannot stand for the characteristics of the lamp, especially to the automotive headlight.

In the application of dimming control, even in the steady state process, the lamp resistance doesn't keep consistent and varies with the lamp arc power. Fig. 1 (a) (b) shows the typical curve of the lamp resistance and the lamp voltage, current and power.

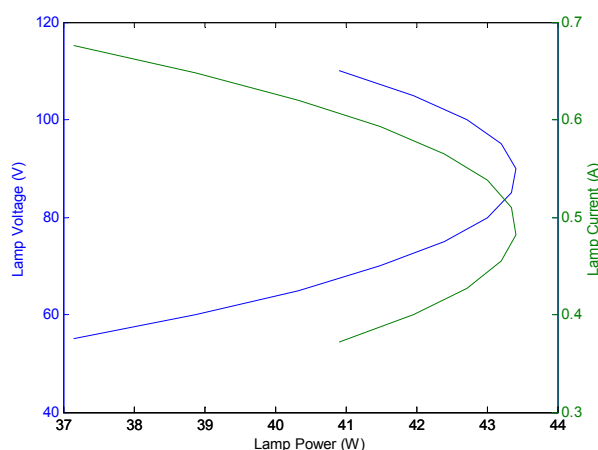

(a)

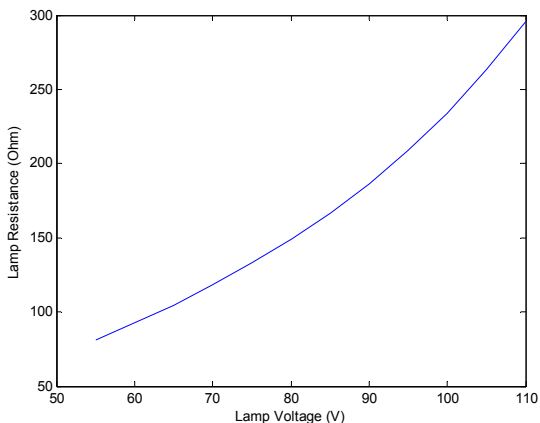

(b)

Fig. 1 (a) The relationship of lamp power (W), voltage (V) and current (A) (b) the lamp resistance in the steady state

In dimming control, a power-dependent equation is used to represent the lamp resistance. A general model is given as: [8]

$$e(t) = f(I_{rms}, V_{rms}, P)i(t) \tag{1}$$

where  $e(t)$  is instantaneous voltage of the lamp,  $i(t)$  is the instantaneous current of the lamp,  $I_{rms}$  is the rms current of the lamp,  $V_{rms}$  is the rms voltage of the lamp and  $P$  is the lamp power. According to equation (1), combining to different topology of the circuit, the lamp model used in the dimming control is established. A detailed modeling process for fluorescent lamp is presented in [9].

### III. DIMMING CONTROL METHOD

#### A. Hardware dimming

The most popular CWA (Constant Wattage Autotransformer) circuit (Seen in Fig.2) is also called two-level dimming systems. The additional capacitor  $C_a$  results in a fixed reduction in power and light output. This circuit cannot give a continuous dimming.

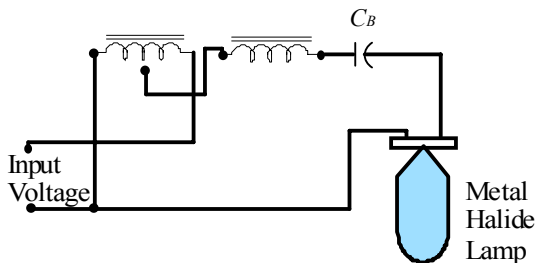

Fig. 2 The most popular CWA (Constant Wattage Autotransformer) circuit

For continuous dimming of HID lamps, there are three different methods. The first one is use of the variable-voltage transformer to reduce the primary voltage supplied to the ballast (Fig. 3). The advantage of this method is that the output is sinusoidal, so harmonics is not

introduced. But the transformer is large, heavy and expensive. This method approximately dimming to 60% of rated lamp power. The second method adds a variable reactor to the circuit, which change the lamp current without affecting the voltage (Fig. 4). In this method, just 30% of rated lamp power is dimmed. In practice, the variable reactor was an effective and comparatively inexpensive way of achieving dimming.

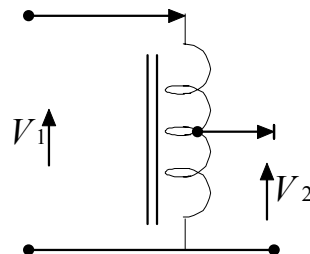

Fig. 3 Variable-voltage Transformer

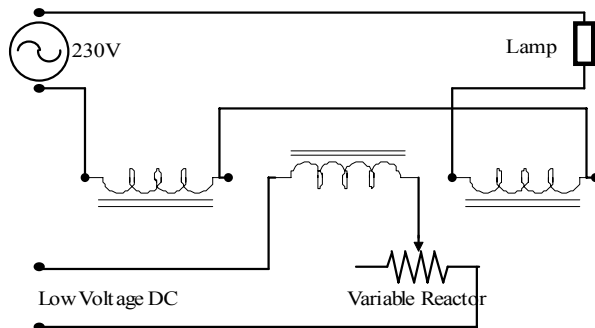

Fig. 4 Reactor Dimmer

The last method is use of the solid-state component to change the waveform of both the current and voltage input to the ballast. This method can dim to 50% of rated lamp power and is also the base of the following sections.

#### B. Control method dimming

The control method dimming is said to the method to change the waveform of both the current and voltage input to the ballast.

##### 1. Variable Switching Frequency control

The variable switching frequency control is popularly used in practical implementation because of its simplicity [10-17]. When the switching frequency is located further away from the resonance of the tank, less energy is coupled to the lamps, and the lamps dim. But an inherent unstable region exists due to the interaction between the negative impedance of the lamps and the output characteristics of the electronic ballast with frequency control. The dimming ballast with variable switching frequency control can only be realized in a limited range, typically 3:1.

The stable dimming range could be extended by using DC-link voltage control [18, 19]. By selecting a switching frequency close to the non-damped natural frequency, the electronic ballasts behave as a current source controlled by the bus voltage.

## 2. Variable Duty-ratio control/Variable Bus Voltage Control

Control the duty cycle of the switches can control the load power. Actually, with the asymmetrical duty-ratio control, a small DC-biased lamp current is obtained [20-22]. But in half-bridge inverter, the maximal duty-ratio is 0.5. Using variable duty-ratio control will change its operation from ZVS to ZCS, if the duty-ratio is small. Variable bus voltage control is close to variable duty-ratio control in a level of performance.

## 3. The Combination of all above

Good performance could be achieved in combined control methods. A variable duty-ratio and frequency control in single-stage PFC electronic dimming ballast with a 3:1 dimming range was reported [14]. A variable bus voltage and switching frequency control for multiple fluorescent lamps applications in two-stage PFC electronic dimming ballast with a dimming range of 3:1 has also been introduced [23]. The strategy combining duty-ratio control and switching frequency control with non-linear compensation has been employed [15]. The reported dimming range is 100:1. However, the control scheme used is very complicated.

## IV. DIMMING RANGE AND STABILITY CONTROL

The dimming range is limited at low intensities due to parasitic capacitance along the lamp, leaving insufficient current to sustain an arc across the whole length of the tube. This phenomenon is commonly referred to as the "thermometer effect". Once the lowest sustainable point has been reached, further reduction in lamp current reduces the length of the lamp that is illuminated, much like a thermometer.

The dimming range of HID lamp is: HPS (High Pressure Sodium) Lamp is 50%-100% (Luminous Flux: 30%-100%); Metal Halide Lamp is 60%-100% (Luminous Flux: 45%-100%) [24]. In addition, in order to avoid the nigrescence of the tube, full output power must be obtained in 3-5 minutes at the start.

In the dimming state of the lamp, the stability control is important. To the new lamp, the dimming range is OK, but with the diminishment of the lamp life, the lamp will extinguish if the power is decreased. So the dimming range will be changed. The detailed analysis will be done combining with practical example.

## V. CONCLUSION

In this paper, a literature survey has been conducted for the electronic ballast for HID lighting. Following the survey, a lamp model for use in the dimming control is developed based on a set of power-based equation. A general model of this type is shown in equation (1). Even though many dimming control methods are used, but most of the dimming performance has much relationship with the topologies of the ballast. The dimming control

methods could be combined with the real system to decouple this relationship. Finally, the dimming range and the stability control is analyzed. The method forms a good base for the good electronic ballast platform for analysis.

## ACKNOWLEDGMENT

The authors would like to thank the support of the Hong Kong Polytechnic University. This work was supported in ITF for the funding support under the project GHS/073/04.

## REFERENCES

- [1] J. F. Waymouth, *Electric Discharge Lamps*, M. I. T. Press, Cambridge, 1978.
- [2] Zhang Weiping, Zhang Yinru, et al. Study of the Model for MH Lamps and the Controlling Approaches for Its Electronic Ballasts. *ACTA ELECTRONICA SINICA*, Vol. 27, No.8, Aug. 1999. Page(s):142-143. (In Chinese)
- [3] W. Elenbaas, *The High Pressure Mercury Vapor Discharge* (North-Holland, Amsterdam, 1951).
- [4] Deng, E.; Cuk, S.; Deng. Negative Incremental impedance and stability of Fluorescent Lamps. *Applied Power Electronics Conference and Exposition, 1997. APEC '97 Conference Proceedings 1997. Twelfth Annual Volume 2*, 23-27 Feb. 1997 Page(s):1050 – 1056.
- [5] Wei Yan; Hui, S.Y.R.; Chan, A universal PSpice model for HID lamps. *Industry Applications, IEEE Transactions on Volume 41*, Issue 6, Nov.-Dec. 2005 Page(s):1594 – 1602.
- [6] Liu, T, Tseng K. J. et al. Pspice model for then electrical characteristics of fluorescent lamps. *IEEE PESC 1998*, Page(s): 1749-1754.
- [7] Laskowski E. L., Donghua J. F. S Model of a Mercury Arc Lamp's Terminal V-I behavior. *IEEE Transactions on Industry Applications*, Vol. 17, No.4, July-Aug. 1981. Page(s): 419-429.
- [8] Correa, J.; Ponce, M.; Arau, J.; Alonso, J.M.; Dimming in metal-halide and HPS lamps operating at HF: effects and modeling. *Industry Applications Conference, 2002. 37th IAS Annual Meeting. Conference Record of the Volume 2*, 13-18 Oct. 2002 Page(s):1467 - 1474 vol.2.
- [9] Moo, C.S.; Chuang, Y.C.; Huang, Y.H.; Chen, H.N. ; Modeling of fluorescent lamps for dimmable electronic ballasts. *Industry Applications Conference, 1996. Thirty-First IAS Annual Meeting, IAS '96., Conference Record of the 1996 IEEE Volume 4*, 6-10 Oct. 1996 Page(s):2231 - 2236 vol.4.
- [10] J. Rozenboom. The electronic ballast circuit and low pressure lamps. *Int. Journal Electronics*, Vol. 82, No.3, 1997, pp. 269-294.
- [11] J. Ribas, J. M. Alonso, E. L. Corominas, et al. Design Considerations for Optimum Ignition and Dimming of Fluorescent Lamps Using a Resonant Inverter Operating Open Loop. *Conference Record of IEEE-IAS 1998*, pp: 2068-2075.
- [12] C. S. Moo, H. L. Chung, et al. Design Dimmable Electronic Ballast with frequency control. *Conference Record of IEEE-APEC 1999*, pp: 727-733.
- [13] T. F. Wu, T. H. Yu, et al. Single-stage Electronic ballast with dimming feature and Unity Power Factor. *IEEE trans. On Power Electronics*. Vol.13, No.3, May 1998. pp: 586-597.
- [14] T. F. Wu, T. H. Yu, et al. Analysis and Design of a High power Factor, Single-Stage Electronic Dimming ballast. *IEEE Trans. On Industry Applications*. Vol. 34, No. 3, May 1998, pp: 606-615.
- [15] T. F. Wu, Y. C. Wu, et al. Design Consideration for Optimum Dimming in Single-stage Electronic Ballasts. *Conference Record of IEEE-IAS 2000*, pp: 3374-3381.
- [16] C. Branas, F. J. Azcondo, et al. Electronic Ballast for HPS Lamps with Dimming Control by Variation of the switching frequency: soft start-up method for HPS and Fluorescent lamps. *Conference Record of IEEE-IECON 1998*, pp: 953-958.
- [17] T. J. Ribarich and J. J. Ribarich. A new Control Method for Dimmable High frequency Electronic Ballasts. *Conference Record of IEEE-IAS 1998*, pp: 2038-2043.

- [18] C. S. Moo, H. L. Cheng, et al. A new Control Method for Dimmable High-frequency Electronic Ballasts. Conference Record of IEEE-ISIE 1999, pp: 786-791.
- [19] S. Y. R. Hui, L. M. Lee, et al. Electronic Ballast with wide Dimming Range, High PF, and low EMI. IEEE Trans. On Power Electronics, Vol. 16, No. 4, July 2001, pp: 465-472.
- [20] J. H. Reijnaerts. Circuit Arrangement for Reducing Striations in a low-pressure Mercury Discharge Lamp. US Patent No. 5,369,339, Nov. 29, 1994.
- [21] R.L. Steigerward and L. D. Stevanovic. Elimination of Striations in Fluorescent Lamps driven by High-frequency Ballast. US Patent No. 5,701,059, Dec. 23, 1997.
- [22] C. R. Sullivan. Control System for Proving Power to a Gas Charge Lamp. US Patent No. 5,864,212, Jan. 26, 1999.
- [23] T.F. Wu, Y. C. Liu, et al. High-efficiency Low-stress Electronic Dimming ballast for multiple Fluorescent Lamps. IEEE Trans. On Power Electronics, Vol.14, No. 1, Jan. 1999, pp: 160-167.
- [24] J. R. Coaton, et al. Lamps and Lighting (Fourth Edition). First published in Great Britain in 1997 by Arnold, a member of the Hodder Headline Group, 338 Euston Road, London, NW1 3BH. Fudan University Press, 2000, 01.

#### BIOGRAPHIES

P. Dong is with the Hong Kong Polytechnic University, Hong Kong, China (phone: 00852-2766-4325; e-mail: 05900654r@polyu.edu.hk).

K. W. E. Cheng, is with the Hong Kong Polytechnic University, Hong Kong, China, (e-mail: eecheng@inet.polyu.edu.hk).