

 Open access • Proceedings Article • DOI:10.1109/PESA.2006.343095

General study for design the HID ballasts — Source link

K.F. Kwok, K. W. Eric Cheng, Dong Ping

Institutions: Hong Kong Polytechnic University

Published on: 01 Nov 2006 - International Conference on Power Electronics Systems and Applications

Topics: Smart lighting, High-intensity discharge lamp, Ballast and Gas-discharge lamp

Related papers:

- [Microcontroller-based electronic ballasts for high-intensity discharge lamps](#)
- [High-voltage discharge lamp ballast, lighting device and lighting system](#)
- [Analysis and Design of High-Intensity-Discharge Lamp Ballast for Automotive Headlamp](#)
- [Energy Saving of Large-Scale High-Intensity-Discharge Lamp Lighting Networks Using a Central Reactive Power Control System](#)
- [Electronic ballasts for gas discharge lamps](#)

Share this paper:    

View more about this paper here: <https://typeset.io/papers/general-study-for-design-the-hid-ballasts-2of0cseew1>

General study for design the HID ballasts

K.F. Kwok, K.W. Eric Cheng, Dong Ping

Power Electronics Research Centre, Department of Electrical Engineering,

The Hong Kong Polytechnic University

Abstract-- High-intensity discharge (HID) lighting lamp systems are widely used in applications that can provide a high light levels are desired for large areas, such as vehicle headlight, industrial and street lighting. Similar to fluorescent lighting systems, all HID lighting systems require a ballast to operate. Traditionally, magnetic ballast designs were the only choice available for HID lighting systems. Today, high-efficiency electronic HID ballasts are available that provide improved lighting quality and reduce lighting electricity use by 10 to 30 percent.

The purpose of this paper is to identify requirements of the ballast interface from the perspective of the HID lamp. This study will generally brief the starting, run-up, and steady state operation of HID lamps on electronics ballasts.

I. INTRODUCTION

HI.D. stands for High Intensity Discharge. It refers to lighting technology that relies on an electrical charge to ignite xenon gas contained in a bulb. HID lighting using the igniting an arc between two electrodes to instead the filament for creates light. HID lights get their name from the intense white light produced by the electrical discharge. The electrical arc produced between the two main electrodes of a HID lamp is much like a runaway short circuit, which can be sustained indefinitely. Once sufficient voltage is present, the gases within the arc tube are "ionized" to where they will conduct the arc current. Arc formation is not an immediate process. It can take several seconds for the arc to be established, and several minutes until full light output is reached [1].

High Intensity Discharge (HID) lamps are being used in more and more applications where lamp color, long life and efficacy are important. From automotive and industrial lighting to theatrical and stage lighting, HID promises to be the light of the future. HID lamps offer many advantages over many other types of discharge lamps because of their luminous efficiency (their ability to convert electrical power to visible light) and the luminous intensity and color of HID is truly like harnessing the brightness of the sun. H.I.D. lighting system delivers instantaneously 3 times the light output of conventional halogen headlamp, consumes only 35-watt per capsule (VS. halogen's 55-watt per bulb), and has a life expectancy of 5 times longer (2000 hr. or more VS. 500 hr. or less)[2].

This work was supported in part by the Guangdong-Hong Kong Technology Cooperation Funding Scheme, Innovation and Technology Fund, Project GHS/073/04.

Traditional HID ballasts use magnetic coils to regulate current and voltage to provide proper lamp starting and operation. These magnetic ballasts tend to be hot, bulky and heavy, which affects their suitability for some applications.

Electronic ballasts are available for HID lighting systems. These ballasts provide the same functions as their magnetic counterparts but use power-supply switching electronics rather than magnetic transformers to operate the lamp. This results in reduced energy losses and improved operating performance.

- *Reduced energy costs, size and weight*
- *Available with a dimming option*
- *Improved light color and output*
- *Flicker-free*
- *Increase the power factor and reduce harmonic distortion*
- *Thirty percent longer lamp life and lower lumen depreciation*

II. HID BALLAST

HID lamps are a negative impedance device. This means that unless controlled, the current would continue to increase, causing the lamp to fail almost instantly after starting. The negative impedance characteristics require a current controlling or limiting device, that is, the ballast to give the power supply to the HID lamp. The ballast serves three functions. It provides the proper starting voltage to establish the arc. Second, it supplies the proper voltage to operate the lamp. Third, the ballast limits the lamp current to a level prescribed by the lamp manufacturer for the particular type of lamp being used. Ballasts must always be matched to the particular lamp type, wattage, and line voltage being used.

A. Magnetic Ballasts for HID Lamp

At first, the magnetic ballast is used in the lighting system. This type of ballast is called starter or something like this and has the merits, such as simple structure, high reliability and long life. But the bulky, high power loss and large noise are its disadvantages. At present, the magnetic ballast is used in metal halide lamp but in Xenon headlight system, due to high requirement, it is difficult to use and the electronic ballast is used. Fig. 1 gives some topologies of magnetic ballast used in USA and Europe [3]

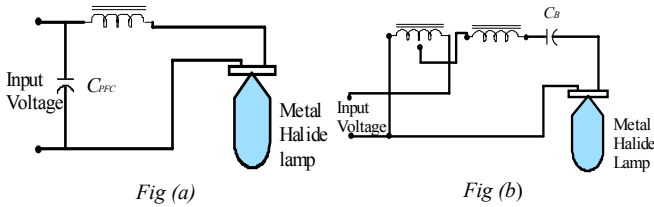

Fig. 1(a) The standard reactor circuit used in USA and Europe (b) The most popular CWA (Constant Wattage Autotransformer) circuit

a.) The standard reactor circuit:

This lag type circuit is the smallest, simplest and most economical type of ballast. The ballasts can only be used when line voltage is relatively stable and at least 10 percent higher than the rated lamp starting voltage. Reactors are generally used as normal power factor devices. It highest current draw occurs during starting which must be allowed for in the capacity of the line. The line current can be lowered by using a capacitor across the line to achieve a high power factor of over 90 percent.

b.) Constant Wattage Autotransformer (CWA) circuit:

This lead type circuit is the most commonly used in high intensity discharge lighting as it can provide stabilized light output compare with the lag type circuit that mean more economic. It can provide to installation where the line voltage fluctuations are greater than +/- 5 percent, but not greater than +/- 10 percent. A 10 percent decrease in line voltage will give only a 5 percent decrease in lamp watts. This is much better than the regulation characteristics of other ballast types. The circuit consists of a high reactance autotransformer with a capacitor in series with the lamp resulting in high power factor ballast. This type of ballast also has a significantly lower dropout voltage than the standard reactor circuit.

B. Electronic Ballast for HID Lamp

At the end of 1970's, Philips and other company developed the AC electronic ballast for fluorescent lamp and after 1990's, the development and research to the electronic ballast used in HID lamp fields are the general focus of the field.

C. The main topologies used in Electronic Ballast:

Many efforts have been made to establish cost-effective electronic ballast. Here gives the main topologies of electronic ballast used in xenon automotive headlight system. Fig. 2 (a & b) are show two main topologies which are the common circuits used in the world.

They are based on the inverter to drive the lamps and the high voltage is needed to ignite the lamps through the transformer. The transformer voltage can be derived from the DC -DC converter or from the resonant circuit.

The design and the configuration for the transformer is very critical as it has to handle the high voltage conversion and the isolation.

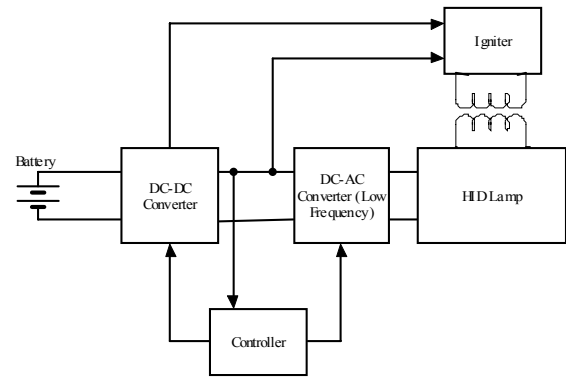

Fig. 2(a) Structure of Traditional HID Ballast

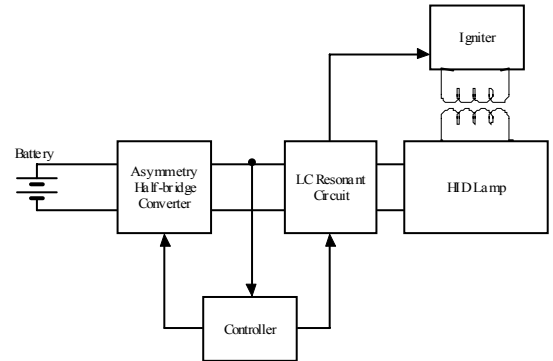

Fig. 2(b) Asymmetry Half-bridge structure of HID ballast

1.) Structure of Traditional HID Electronic Ballast

The rated operation voltage of xenon lamp is 85V, but the input is battery whose voltage is around 12V, hence using the DC-DC converter for step-up the voltage. Generally speaking, the boost converter, flyback converter and sepic converter can all be used. Fig. 3 shows the topologies of these converters.

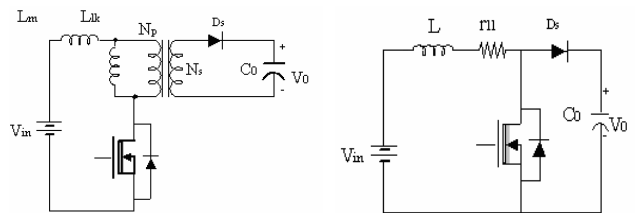

Fig 3 (a)

Fig 3 (b)

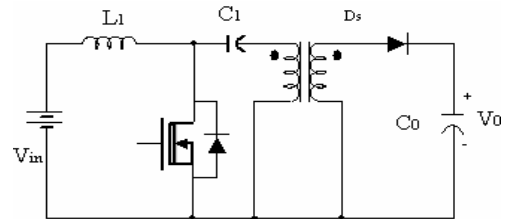

Fig 3 (c)

Fig 3 (a) Flyback Converter (b) Boost Converter (c) Sepic Converter

In flyback converter, the transformer is used to increase the output voltage but the leakage inductor L_{lk} will cause the voltage pulsation. In order to reduce this pulsation, a snubber circuit is used in the input of the transformer which will cause a low efficiency and high cost.

In boost converter, the step-up voltage just obtained by adjusting the duty ratio. It is very difficult to realize the

high output voltage. In addition, the resistance of the inductor will reduce the efficiency; hence, the boost converter just used at low output voltage occasion.

In sepic converter, the same as the flyback converter, due to the existence of the transformer, it can reduce the EMI and realize the insulation between input and output. But it is better than flyback converter in the smaller size of the transformer.

2.) DC-AC Inverter

Generally, HID lamps cannot be operated on sinusoidal high-frequency currents between about 1-300 kHz because of arc instability owing to the acoustic resonance of high-temperature vaporized gases. Conventional wisdom recommends that the lamps be operated on 100-400Hz alternating rectangular current (Fig. 4) [3], [4]. The DC-AC inverter circuit has a function to invert dc current to alternating rectangular current.

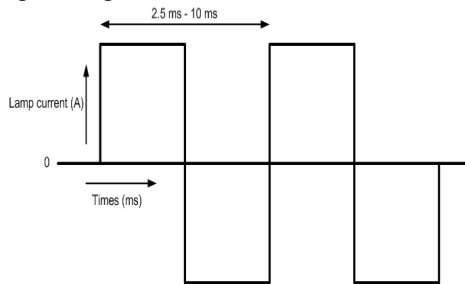

Fig 4 Current waveform of HID Lamp for stable operation

So a full-bridge inverter is commonly used Fig. 5 (a). Usually, the half-bridge can be used in this converter Fig. 5 (b), but the high voltage gives high requirement to the switch, because each switch will stand for the whole input voltage.

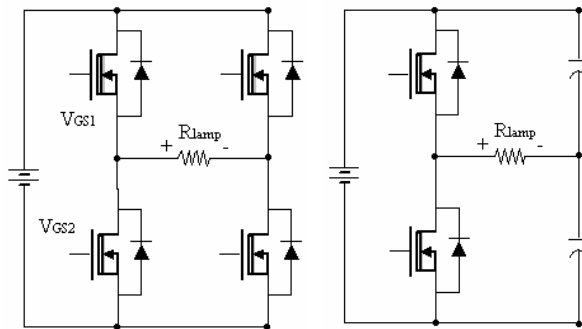

Fig. 5 (a) Full-bridge Inverter (b) Half-bridge Inverter

3.) Igniter

The function of the igniter is providing increased open circuit voltage. Because of the HID lamps need an appropriate voltage across the electrodes to initiate and maintain glow discharge. Furthermore the ballast should provide sufficient current at glow discharge voltage forcing the glow-to-arc transition. So starting voltage of HID lamp is one of the major problems in ballast design. Resonant tank was used in the igniter to obtain the high starting voltage [5]. Fig 6 (a) & (b) are shown the general circuit for the igniter.

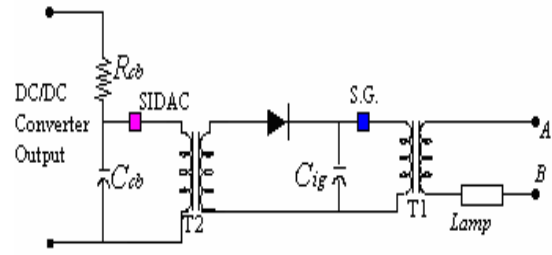

Fig 6 (a) Two-stage igniter

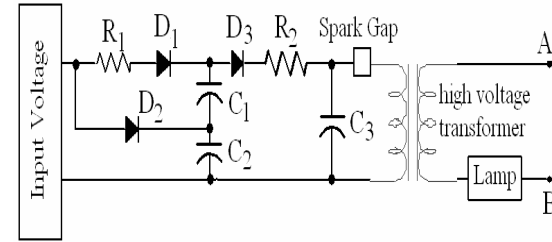

Fig 6 (b) Voltage double igniter

Two stages of step-up circuits with two step-up transformers were used in igniter [6], but the circuit reliability is decreased, and the power loss is increased due to the use of more transformers. The disadvantage of the voltage double circuit is easy to saturate at the high voltage when the lamp runs in the steady state. In addition, the high voltage is realized using one transformer which will give much higher requirement to the transformer.

(4) Controller

This is the main part of the electronic ballast which will give the signals to the DC-DC converter and DC-AC inverter.

Constant Voltage Control: The voltage of the lamp is the control variable, if this voltage is constant, the output power of the lamp will less than the rated power with the operating time increased. Hence, the output luminous of the lamp is not enough.

Constant Current Control: The current of the lamp is the control variable, but it is just suitable for a few times. With the ageing of the lamp and due to the negative impedance characteristic of the lamp, the voltage of the lamp will increase which will cause the lamp ageing, even to destroy the electronic ballast.

Constant Power Control: This control method will control the current and voltage instantaneously, that is, the luminous is controlled. It is good to the lamp and electronic ballast. So it is common used in the market. But the control is complex.

C. Asymmetry Half-bridge structure of HID ballast

Using the resonant voltage to ignite the HID lamp, the LC resonant circuit is considered with the DC-AC inverter. If the DC-AC inverter is the full bridge, there are three igniters which use a resonant rank LC to filter the square waveform provided by the inverter. The typical circuit is given as Fig. 7 [7].

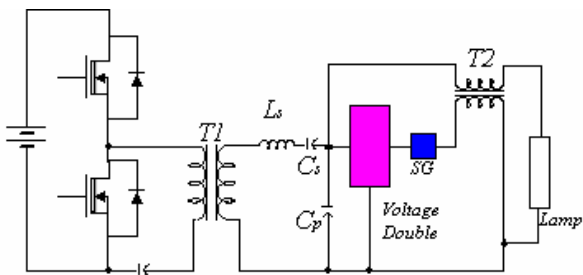

Fig.7 Asymmetry Half-bridge structure of Electronic ballast

The output voltage & current of the HID lamp was shown in the Fig 8(a). Channel 1 is the lamp voltage & channel 2 is the lamp current.

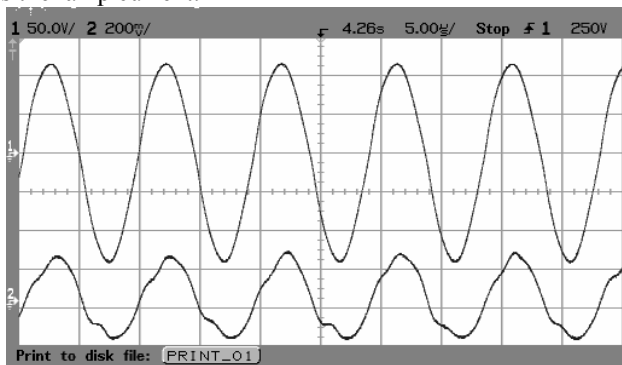

Fig 8 HID Lamp output Voltage & Current waveform

The gate signal waveform of two MOSFET was shown as below Fig 9. Channel 1 is the upper side MOSFET and the channel 2 is the lower side MOSFET of the half-bridge circuit.



Fig 9 The gate signal waveform

Using the resonant voltage to ignite the HID lamp, the LC resonant circuit is considered with the DC-AC inverter. If the DC-AC inverter is the full bridge, there are three igniters which use a resonant rank LC to filter the square waveform provided by the inverter. The lamp voltage can get from the capacitor or inductor and Fig. 8 shows three different topologies [8].

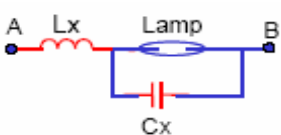

Fig 10 (a)

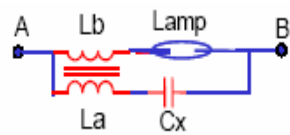

Fig 10 (b)

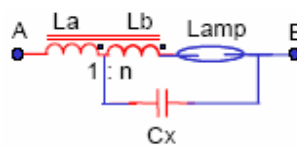

Fig 10 (c)

Fig. 10 (a) LC resonant Tank (b) Transformer configuration (c) Autotransformer configuration

The resonant voltage across C_x provides the required high voltage to the lamp. To obtain voltage higher than the resonant voltage, an additional winding is applied. As shown in Fig. 10 (b), the two inductors L_a and L_b are magnetically coupled and operate as a transformer. When the inductor L_a and capacitor C_x operate close to the resonant frequency, the lamp voltage is equal to the voltage across the inductor L_b . To exploit the voltage across the inductor L_a as well, the configuration of autotransformer was proposed, as shown in Fig. 10 (c). But this kind of circuit just suit for the low power ballast.

III. CONCLUSION

This paper has been addressing the general study for HID ballast which includes the magnetic ballast & electronics ballast. The two typical topology standard reactor & CWA were discussed for the magnetic ballast. The main elements (DC-DC converter, DC-AC Inverter, Igniter & Control) for traditional electronic ballast were identified for different topologies. Acoustic resonances are the main concern for design the electronic ballast. In conclusion it may be stated that the occurrence of acoustic resonances at high frequency can be considered as a limitation factor for a wide and reliable application of high frequency electronic ballasts supplying HID lamps.

IV. REFERENCES

- [1] **EnerGuide for Industry** Office of Energy Efficiency Natural Resources Canada 1 Observatory Crescent, Building #1 Ottawa ONK1A0E4 "http://oee.nrcan.gc.ca/egi/english/lighting/lighting_contents.cfm?PrintView=N&Text=N"
- [2] **SigmaAutomotive-617-344-8396** "http://www.sigmaautomotive.com/HID/hid.php"
- [3] H. Kakehashi, M. Habu, T. Ninomiya, H. Ogasawara, and Y. Ohta. HID-lamp igniter using a two-stage magnetic-pulse-compression circuit, Proc. of APEC'98, Vol.2, pp.1174-1179, 1998.
- [4] N. Aoike, M. Hoshino, & a. Iwabuchi, "Automotive HID Lamps producing compact electronics ballasts using power ICs" in IEEE Industry Applications Magazine Jan-Feb 2002
- [5] Yifeng Jiang; Qiukai Huang; Min Chen; Zhaoming Qian; Analysis and design of a new hot-striking igniter for HID lamp. Industry Applications Conference, 2004. 39th IAS Annual Meeting. Conference Record of the 2004 IEEE Volume 1, 3-7 Oct. 2004 Page(s).
- [6] Kyu-Chan Lee; Bo Hyung Cho; Design and analysis of automotive high intensity discharge lamp ballast using micro controller unit. Power Electronics, IEEE Transactions on Volume 18, Issue 6, Nov. 2003 Page(s):1356 - 1364.
- [7] T. J. Ribarich and J. J. Ribarich. A new Control Method for Dimmable High frequency Electronic Ballasts. Conference Record of IEEE-IAS 1998, pp: 2038-2043.
- [8] T. J. Ribarich and J. J. Ribarich. A new Control Method for Dimmable High frequency Electronic Ballasts. Conference Record of IEEE-IAS 1998, pp: 2038-2043.