

Generalized Fast Feedback System in the SLC*

L. Hendrickson, S. Allison, T. Gromme, T. Himel, K. Krauter,
 F. Rouse,[†] R. Sass and H. Shoae

Stanford Linear Accelerator Center, Stanford University, Stanford, CA 94309

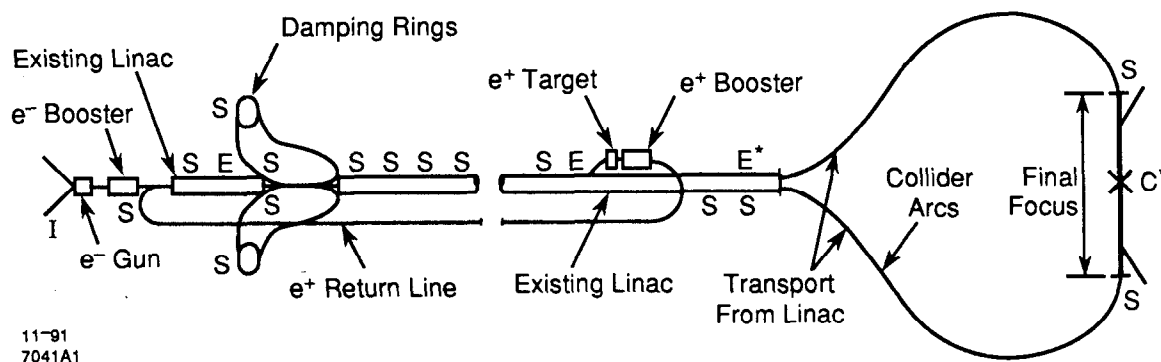

11-91
 7041A1

Figure 1: Layout of the SLC with fast feedback loops shown. S = steering loop; E = energy control; I = intensity control; C = special-purpose loop to maintain beam collisions; * = prototype.

Abstract

A generalized fast feedback system has been developed to stabilize beams at various locations in the SLC. The system is designed to perform measurements and change actuator settings to control beam states such as position, angle and energy on a pulse to pulse basis. The software design is based on the state space formalism of digital control theory. The system is database-driven, facilitating the addition of new loops without requiring additional software. A communications system, KISNet, provides fast communications links between microprocessors for feedback loops which involve multiple micros. Feedback loops have been installed in seventeen locations throughout the SLC and have proven to be invaluable in stabilizing the machine.

INTRODUCTION

The SLAC Linear Collider (SLC) produces pulsed bunches of electrons and positrons which are accelerated in a

LINAC and steered around arcs before colliding at a single interaction point. The maximum beam rate for the machine is 120 Hertz. The SLC control system is based upon a central DEC VAX 8800 and a series of Intel 80386 microprocessors (micros). The micros are distributed geographically, with each micro controlling the devices which accelerate, steer and measure the beam in a region of the machine. The VAX communicates with the micros through a specialized network system, SLCNET, but with the exception of this fast feedback system the micros do not ordinarily communicate with each other.

The feedback system is used for controlling the energy, trajectory and intensity of the beams. The system takes measurements, calculates state functions and implements corrections at a fast rate. It is designed to operate at the beam rate but due to CPU limitations it operates at a lower rate, typically 20 Hertz. Figure 1 shows the SLC machine with currently implemented and planned feedback loops. Prototype feedback systems were initially implemented in three locations for steering, controlling the beam energy [1] and maintaining collisions [2]. These systems quickly became indispensable to the machine operation and an improved, database-driven system was developed to allow easy addition of new loops throughout the machine.

*Work supported by Department of Energy contract DE-AC03-76SF00515.

[†]Present address: University of California, Dept. of Physics, Davis, CA 95616.

SYSTEM OVERVIEW

The system is generalized and database-driven. New feedback loops which behave in a linear fashion are implemented by configuring the database and hardware but without requiring additional software. Furthermore, special-purpose capability is provided to handle non-linear functions such as energy control with phase shifters. The system is based on the state space formalism of digital control theory [3]. Vectors of measurements, states and actuator values are manipulated using matrix and vector arithmetic. Matrices are calculated offline and stored in a database for online use. Measurements input to the feedback system are typically Beam Position Monitor (BPM) readings. The state vector includes calculated quantities such as beam position, angle or energy which the feedback loop controls to user-selected setpoints. Actuators which control the beam are typically analog control devices such as steering dipole magnets, Klystron amplitude controllers and phase shifters.

The major software components of the system are shown in Figure 2. Most of the associated software is written in the C programming language. The SLC database contains device specifications, display information and control parameters associated for all existing feedback loops. Only the software which runs on the VAX has access to the entire database. The VAX software is responsible for initializing and arbitrating feedback processing in the micros and handling user requests. There is an extensive selection of displays available to allow users to monitor and analyze the feedback behavior in addition to facilitating studies of the SLC itself. The VAX software uses an object-oriented architecture. Feedback loops, database-driven displays, and vector elements are among the types of objects which are manipulated in a generalized manner [4].

The micro software executes all of the real-time control functions, including taking measurements, performing calculations and implementing new actuator settings. Since these functions may be distributed across several micros, a specialized high rate network system, KISNet [5], has been adapted from the Advanced Light Source (ALS) project in order to transfer measurement and actuator data between micros. The feedback software which runs on the micros is divided into three functions: measurement, control and actuation. For a single feedback loop there may be multiple measurement and actuator tasks running on different micros with each responsible for its own hardware. A single controller task for each loop receives all of the measurement data, performs calculations, and sends new settings to the actuator task(s).

The matrices used in the controller calculations are determined by an offline simulation program [6] which is based on the MatrixX package from Integrated Systems Incorporated. The matrices are designed to minimize the RMS of the controlled states, provide good response to step functions, and to maintain stability when the machine response does not exactly match the model. The design

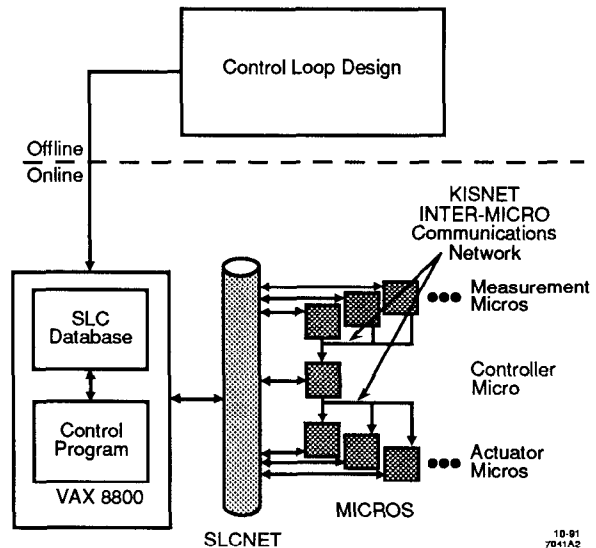

Figure 2: Feedback System Architecture.

involves tradeoffs between quick response and stability under changing beam conditions. The response characteristics may be tuned in the matrix design by adjusting the noise spectrum expected from the accelerator, although in the SLC the same setup is typically used for all loops. The matrices are initialized using the theoretical model of the accelerator. The model is usually good over short distances.

The simulation program has been very useful for predicting stability of the feedback processing and determining the workability of new algorithms. Most of the problems encountered in operation were predicted in advance by the simulator, and some potential problems were circumvented by the software. This is one of the reasons that commissioning the feedback loops has been a remarkably smooth and minimally invasive process.

FEEDBACK CALCULATIONS

The feedback algorithm can be summarized in two equations which are based on the predictor-corrector formalism of digital control theory [3]. This algorithm has previously been described elsewhere [6] in further detail. The first controller equation estimates the values of states which are associated with the feedback loop, based on the previous state estimate, currently implemented actuator settings, and measurements.

$$\hat{\mathbf{x}}_{k+1} = \Phi \hat{\mathbf{x}}_k + \Gamma \mathbf{u} + \mathbf{L}(\mathbf{y} - \mathbf{H} \hat{\mathbf{x}}_k) \quad , \quad (1)$$

where

$\hat{\mathbf{x}}_k$ is the estimate of the state vector on the k^{th} pulse.

Φ is the system matrix and describes the dynamics of the accelerator model.

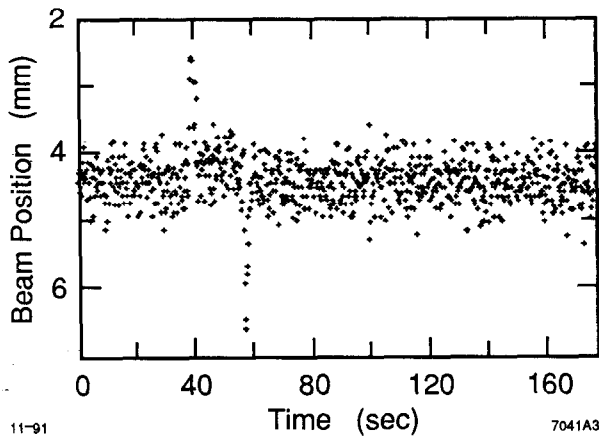

Figure 3: Feedback Response to Step Functions.

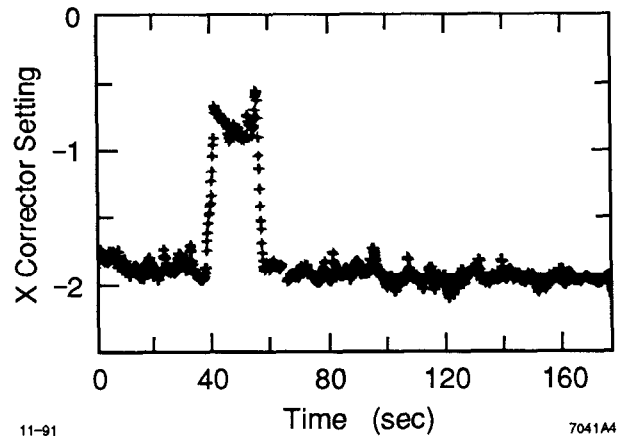

Figure 4: Actuator Control for Step Functions.

Γ is the control input matrix. It describes how changes in the actuators should affect the state.

\mathbf{u} is the actuator vector. It contains the current actuator settings with reference values subtracted.

\mathbf{L} is the Kalman filter matrix. Given an error on the estimate of the sensor readings, it applies a correction term to the estimate of the state vector.

\mathbf{y} is the measurement vector. It contains the current measurements with reference values subtracted.

\mathbf{H} is the output matrix. It maps the state vector to the output vector. That is, given an estimate of the states, it gives an estimate of what the sensors should read.

The matrices Φ , Γ , and \mathbf{H} are obtained from the model of the accelerator. The \mathbf{L} matrix is derived from the other matrices and is designed (via the Linear Quadratic Gaussian method) to minimize the RMS error on the estimate of the state.

The second controller equation calculates the actuator settings based on the estimated state vector.

$$\mathbf{u}_{k+1} = \mathbf{K}\hat{\mathbf{x}}_{k+1} + \mathbf{N}\mathbf{r} \quad (2)$$

where

\mathbf{K} is the gain matrix. It is derived in a manner similar to \mathbf{L} . It is designed to minimize the RMS of selected state vector elements.

\mathbf{N} is the controller-reference-input matrix. It maps the reference vector to actuator settings and is directly derivable from the model of the accelerator.

\mathbf{r} is the reference vector which contains setpoints for the states controlled by the loop.

DIAGNOSTIC CAPABILITY

The micros save measurement, state and actuator data for the last few hundred iterations in a ring buffer; this data is available for display upon user request. These ring buffer displays are one of the most useful diagnostics of the system, enabling analysis of perturbations and beam losses after they have taken place. If the user requests the display within a minute or so after such an event, the associated data is usually available. This functionality is also useful for studies of beam jitter and other phenomena. Figure 3 shows how a feedback-controlled beam position changes with time. Figure 4 shows the associated corrector values during the same time period. During this period, two step functions were purposely introduced to perturb the beam upstream of the feedback loop in order to test the feedback response; one can see how each perturbation is corrected within several pulses. Typically, the first pulse after a large perturbation is rejected by the feedback filtering software as spurious and then the new state estimate is exponentially averaged over several pulses. Newly calculated settings are usually implemented within one or two pulses for most types of actuators.

Additional analysis capabilities include Fourier transforms and plots of the ring buffer data. The same data may be formatted onto disk files which are compatible with offline analysis packages. Beam orbit plots are available to graphically display the beam trajectory through the range of each feedback loop for comparison with the model-predicted orbit. A history plot capability enables review of feedback control over a period of days, weeks or months. Figure 5 shows how a feedback-controlled beam position differs from its setpoint value over a period of fifteen days. The tolerance lines show that for most of the period shown the feedback loop controlled the beam successfully.

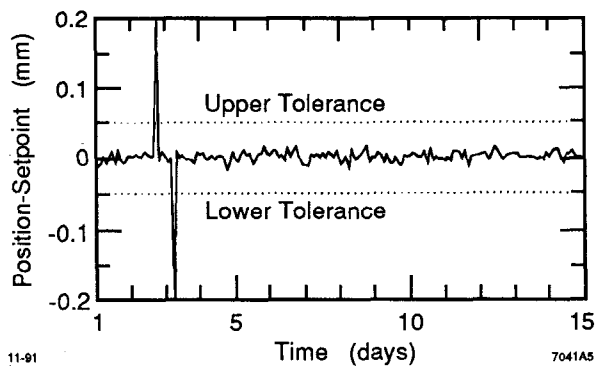

Figure 5: History Plot of Feedback Control.

ADDITIONAL FEATURES

Many system features have been added to the basic algorithm to handle exceptions, improve robustness and add flexibility to the system. For example, a gain factor is implemented as a modification to the second controller equation (actuator calculation), allowing online adjustment of the loop response. The matrices are set up to provide optimal control with a gain factor of 1.0 but it is convenient to allow operators to modify this in response to various operational problems.

An additional capability is the handling of "gold orbits" and loop setpoints. A gold orbit is saved by operators when the state of the accelerator in the region of a feedback loop is believed to be well-tuned. This results in saving the current measurement values and actuator settings. The "gold" measurements are used as offsets in the controller equations. In general the feedback loop will try to control the beam to maintain the gold orbit measurements. The gold orbit values are saved in configuration files which can be reloaded at a later time, facilitating easy reproduction of a particular machine configuration. The operators may wish to tune the machine while the feedback is on by changing the setpoints which control the associated state values. Setpoints may be entered manually, or they may be assigned to a knob and adjusted by turning the knob.

In order to insure that the feedback system does not misbehave, a large part of the micro software involves exception handling. In fact only a small part of the micro software is required for implementing the basic control algorithm. The measurement and actuator values are checked to verify that they are within reasonable limits. If measurements are out of range, have bad status or are not received by the controller, the "expected" values are used in the calculation, based upon the previous state estimates. This allows feedback loops which control both electron and positron beams to continue controlling one beam when the other beam is absent. In order to insure that a single wild pulse does not adversely impact the feedback response, two types of filtering are implemented. Firstly, measurements which vary significantly from the previous pulse are not used unless the value is between

that of the two previous pulses. Secondly, an exponential filtering mechanism is built into the matrices to improve stability.

A calibration function is provided for online measurement of how the beam states change with actuator settings. After the calibration is performed, the user may compare the resulting matrices with the model values and with the currently implemented matrices. An option is provided to implement the new values. This function facilitates diagnosis of how well the feedback loop is performing in addition to improving the feedback response when the model is imperfect.

TESTING ENVIRONMENT

In order to test the initial system as well as new developments, a hardware-based feedback test system has been developed. The typical test feedback loop has three measurements, two states and two actuators. The hardware simulator modifies the values of the measurements to respond to changes in the actuators. A function generator introduces variances in the measurements such as sine-waves or step functions. In addition to facilitating debugging and testing of software features without impacting operation of the SLC, the simulator enables the study of feedback response for various system changes.

OPERATIONAL EXPERIENCE

The feedback system was first commissioned in the SLC in November 1990. Since then seventeen feedback loops have been implemented, with more planned. These are shown in Figure 1. At the front end of the machine a new feedback loop will soon control the intensity of the beam from the polarized laser gun. Steering loops control the beam trajectory from the injector into the linac and also into the damping rings. Additional loops steer the beams out of the damping rings, down the LINAC and into the final focus. An energy loop controls the electron and positron beams into the damping rings. A special-purpose calculation is used to control the energy of the electron beam into the positron target. Furthermore, the prototypical systems for energy control at the end of the LINAC and interaction point collision control are scheduled to be replaced by the generalized software in the near future. Additional steering and energy loops are planned for the new Final Focus Test Beam facility.

The number of feedback loops implemented is much larger than originally planned. More loops were added because of the success of the initial loops and the ease of commissioning. The system worked much better than anticipated. Loops which involve a single micro could be added just by setting up database entries, without requiring any additional hardware or software. Most feedback loops were commissioned by turning them on with a small gain factor, gradually turning up the gain, and monitoring

the loop response by looking at the feedback displays. One of the feedback loops was commissioned “accidentally” by an operator who didn’t realize the loop wasn’t ready; he just turned it on and it worked.

Fast feedback has become an important part of the SLC Control System and is heavily relied upon for stabilizing the machine. It is now much easier to reproduce a particular machine state after interruptions. Furthermore, operators who were previously occupied with keeping the beams stable have been freed to work on more subtle aspects of machine tuning. Since the system was implemented, the average rate of steering knob turns has decreased by a factor of five. The LINAC is now steered every few days instead of once a shift. The orbit bumps required to minimize the beam emittance are now stable for weeks instead of hours. There are fewer machine protection trips because the scavenger energy feedback keeps the beams centered. Since the feedback system was implemented, accelerator performance has been greatly improved and much of this improvement is attributable to fast feedback. All of the major operational goals for the SLC in the last running period were met or exceeded.

“CASCADED” FAST FEEDBACK

One problem encountered in operation was predicted by the initial simulations and is a result of the large string of steering loops down the LINAC. In the current system, these loops are all controlling the same parameters, resulting in overcorrection of upstream perturbations and amplification of beam noise. As a temporary measure, the gain factors of several feedback loops have been decreased, but this reduces the system’s effectiveness.

An enhancement to the feedback system, called “Cascading”, is currently under development. It enables a series of fast feedback loops to communicate, eliminating overcorrection problems and allowing the use of optimal gain factors. In the new system, each upstream loop sends its calculated state vector to the adjacent downstream loop. It is not necessary for an upstream loop to communicate with all loops downstream of it. The downstream loop controls the difference between state elements calculated from downstream beam position monitors and the transported values of the associated states calculated by the upstream feedback loop. This results in each loop correcting only those perturbations not already removed by the upstream loops.

This coordination between feedback loops depends upon a reliable method for mathematically transporting the position and angle at one point to the position and angle at a downstream location. The model of the accelerator, based upon a knowledge of the focusing strengths of the LINAC quadrupoles, provides a basis for this transport, but it is believed that the model is not acceptably accurate over the distances involved. Furthermore, the physical transport characteristics may change during operation. Therefore adaptive methods are used to dynamically up-

date the transport matrices. The adaption calculations are based upon the SEquential Regression (SER) algorithm [7], adapted for use in the SLC feedback system [8].

The adaption is an iterative process which has as inputs the calculated states for a feedback loop and the same states as calculated by an upstream loop. Averaged over time, the transported upstream states should equal the downstream states. The adaption process calculates a transfer matrix which minimizes the difference between the transported upstream and downstream states. This process runs on the same micro as the feedback controller but is implemented as a separate task, allowing the adaption to run more slowly and at a lower priority in order to minimize the CPU impact.

The algorithm is as follows: On each pulse for which the transport matrix is to be updated the following is calculated:

$$\mathbf{S} = \mathbf{Q}(k-1)\mathbf{y}_c(k) \quad (3)$$

$$\gamma = \frac{\alpha}{1-\alpha} + \mathbf{y}_c^T(k)\mathbf{S} \quad (4)$$

$$\mathbf{Q}(k) = \frac{1}{\alpha} \left(\mathbf{Q}(k-1) - \frac{1}{\gamma}\mathbf{S}\mathbf{S}^T \right) \quad (5)$$

where:

$\mathbf{y}_c(k)$ is the state vector from the upstream loop with setpoints subtracted.

k is the beam pulse number.

\mathbf{Q} is the estimate of the inverse of the covariance matrix of \mathbf{y}_c .

\mathbf{S}, γ are intermediate results.

and

$$\alpha = 2^{-1/\tau} \quad (6)$$

where

τ is the number of pulses for covariance matrix averaging, typically 50.

A large γ means the beam fluctuation has suddenly increased, which could cause the transport calculation to be unstable. Therefore the following equations which update the transport matrix are calculated only if γ is less than a cutoff value, typically 20.

$$\begin{aligned} \epsilon &= (\text{raw state vector}) - (\text{raw state setpoints}) \\ &\quad - \mathbf{T}_c(k)\mathbf{y}_c(k) \end{aligned} \quad (7)$$

$$\begin{aligned} \mathbf{T}_i(k+1) &= \mathbf{T}_i(k) + \\ &\quad \eta \mathbf{Q}(k)\mathbf{y}_c(k)\epsilon_i \end{aligned} \quad (8)$$

where

\mathbf{T}_i is the estimate of the i^{th} row of the transport matrix \mathbf{T}_c .

η is the learning rate or gain, typically 0.1 or 0.2.

The calculation of T_i must be evaluated for all i , that is for each row of the transport matrix. If there are changes to the physical model the T and Q matrices converge to new values within a few minutes.

Simulations indicate that this method will behave reliably and will improve the feedback response. It should completely eliminate the overcorrection problems previously experienced. The new system is scheduled to be ready for commissioning by the end of 1991.

CONCLUSIONS

The new fast feedback system has been a remarkably successful addition to the SLC Control System. The generalized approach enables easy addition of new loops and expansion of functionality. Commissioning of new loops has caused relatively little negative operational impact, due to use of simulation and offline testing. The database-driven design and reliance upon existing hardware also helps to minimize commissioning effort. The user interface is easy for operators to use and provides extensive analysis capability. Most importantly, the system has improved the stability and tuning of the SLC, enabling operational goals to be met.

ACKNOWLEDGEMENTS

The authors wish to thank J. Zicker and S. Castillo for their work on the system design. We also appreciate the software contributions of P. Grossberg, R. Hall and L. Patmore.

REFERENCES

- [1] G. Abrams et al., "Fast Energy and Energy Spectrum Feedback in the SLC LINAC," SLAC-PUB-4183, in *Proceedings of the Particle Accelerator Conference*, Stanford Linear Accelerator Center, March 1987.
- [2] F. Rouse et al., "Maintaining micron size beams in collision at the Stanford Linear Collider," SLAC-PUB-5512, in *Proceedings of the IEEE Particle Accelerator Conference*, Stanford Linear Accelerator Center, May 1991.
- [3] Gene F. Franklin and J. David Powell, *Digital Control of Dynamic Systems*, Addison-Wesley, 1980.
- [4] F. Rouse et al., "Design of VAX Software for a generalized feedback system," SLAC-PUB-5511, in *Proceedings of the IEEE Particle Accelerator Conference*, Stanford Linear Accelerator Center, May 1991.
- [5] K. Krauter and D. Nelson, "SLC's Adaptation of the ALS High Performance Serial Link," in *Proceedings of the IEEE Particle Accelerator Conference*, Stanford Linear Accelerator Center, May 1991.
- [6] T. Himel, L. Hendrickson, F. Rouse and H. Shoaee, "Use of Digital Control Theory State Space Formalism for Feedback at SLC," SLAC-PUB-5470, in *Proceedings of the IEEE Particle Accelerator Conference*, Stanford Linear Accelerator Center, May 1991.
- [7] Bernard Widrow and Samuel D. Stearns, *Adaptive Signal Processing*, Prentice-Hall, Inc., 1985.
- [8] T. Himel, "Requirements and Design Overview for Adaptive Cascaded Feedback," Internal SLAC document, Stanford Linear Accelerator Center, September 1991.