

Research Article

Generalized Kudryashov Method for Time-Fractional Differential Equations

Seyma Tuluce Demiray,¹ Yusuf Pandir,² and Hasan Bulut¹

¹ Department of Mathematics, Firat University, 23119 Elazig, Turkey

² Department of Mathematics, Bozok University, 66100 Yozgat, Turkey

Correspondence should be addressed to Seyma Tuluce Demiray; seymatuluce@gmail.com

Received 25 March 2014; Revised 9 June 2014; Accepted 9 June 2014; Published 16 July 2014

Academic Editor: Dumitru Baleanu

Copyright © 2014 Seyma Tuluce Demiray et al. This is an open access article distributed under the Creative Commons Attribution License, which permits unrestricted use, distribution, and reproduction in any medium, provided the original work is properly cited.

In this study, the generalized Kudryashov method (GKM) is handled to find exact solutions of time-fractional Burgers equation, time-fractional Cahn-Hilliard equation, and time-fractional generalized third-order KdV equation. These time-fractional equations can be turned into another nonlinear ordinary differential equation by travelling wave transformation. Then, GKM has been implemented to attain exact solutions of time-fractional Burgers equation, time-fractional Cahn-Hilliard equation, and time-fractional generalized third-order KdV equation. Also, some new hyperbolic function solutions have been obtained by using this method. It can be said that this method is a generalized form of the classical Kudryashov method.

1. Introduction

Partial differential equations are prevalently used as models to identify numerous physical occurrences and have a very crucial role in many sciences. Burgers equation, which is one type of partial differential equations, was first presented by Burgers in 1948 as a model for turbulent phenomena of viscous fluids [1]. The Burgers equation defines the far field of wave propagation in nonlinear dissipative systems. It is well known that this equation is linearizable to the heat equation by using the Cole-Hopf transform. This equation has been considered in a number of fields of implementation such as traffic flows and formation of large clusters in the universe.

The Cahn-Hilliard equation, which is one type of partial differential equations, was first introduced in 1958 as a model for process of phase separation of a binary alloy under the critical temperature [2]. This equation has also arisen as the modelling equation in numerous other contexts with very disparate length scales. For example, models have been improved in which the Cahn-Hilliard equation is used to represent the evolution of two components of intergalactic material or in ecology in the modeling of the dynamics of two populations or in biomathematics in modeling the dynamics

of the biomass and the solvent components of a bacterial film [3].

Korteweg-de Vries (KdV) equation, which is one type of partial differential equations, has been utilized to define a wide range of physical phenomena as a model for the evolution and interaction of nonlinear waves. It was derived as an evolution equation that conducting one-dimensional, small amplitude, long surface gravity waves propagating in a shallow channel of water [4]. Subsequently, the KdV equation has occurred in a lot of other physical sciences such as collision-free hydromagnetic waves, stratified internal waves, ion-acoustic waves, plasma physics, and lattice dynamics. Some theoretical physical occurrences in the quantum mechanics domain are expressed by means of a KdV model. It is utilized in fluid dynamics, aerodynamics, and continuum mechanics as a model for shock wave formation, solitons, turbulence, boundary layer behaviour, and mass transport [5].

The enquiry of exact solutions to nonlinear fractional differential equations has a very crucial role in several sciences such as physics, viscoelasticity, signal processing, probability and statistics, finance, optical fibers, mechanical engineering, hydrodynamics, chemistry, solid state physics, biology, system identification, fluid mechanics, electric control theory,

thermodynamics, heat transfer, and fractional dynamics [6–8]. In recent years, most authors have improved a lot of methods to find solutions of fractional differential equations such as local fractional variational iteration method [9, 10], cantortype cylindrical-coordinate method [11], fractional complex transform method [12], and homotopy decomposition method [13]. Also, exact solutions of fractional differential equations have been considered by using many methods such as the extended trial equation method [14, 15], the modified trial equation method [16, 17], a multiple extended trial equation method [18], and the modified Kudryashov method [19–21].

Our goal in this work is to introduce the exact solutions of time-fractional Burgers equation [16, 22], time-fractional Cahn-Hilliard equation [23–25], and time-fractional generalized third-order KdV equation [14, 22, 26–29]. In Section 2, we give the description of proposed method. In Section 3, as illustrations, we gain exact solutions of time-fractional Burgers equation [16, 22]:

$$\frac{\partial^\alpha u(x, t)}{\partial t^\alpha} - u_{xx} - \beta u^p u_x = 0, \quad t > 0, \quad p > 0, \quad 0 < \alpha \leq 1, \tag{1}$$

time-fractional Cahn-Hilliard equation [24]:

$$\frac{\partial^\alpha u(x, t)}{\partial t^\alpha} = u_x + 6u(u_x)^2 + (3u^2 - 1)u_{xx} - u_{xxxx}, \tag{2}$$

$$t > 0, \quad 0 < \alpha \leq 1,$$

and time-fractional generalized third-order KdV equation [14, 22]:

$$\frac{\partial^\alpha u(x, t)}{\partial t^\alpha} - u_{xxx} - \gamma u^p u_x = 0, \quad t > 0, \quad p > 0, \quad 0 < \alpha \leq 1, \tag{3}$$

where α is a parameter describing the order of the fractional derivative.

2. The Generalized Kudryashov Method

Recently, some authors have investigated Kudryashov method [30–32]. But, in this work, we try to constitute generalized form of Kudryashov method.

We consider the following nonlinear partial differential equation with fractional order for a function u of two real variables, space x and time t :

$$P(u, D_t^\alpha u, u_x, u_{xx}, u_{xxx}, \dots) = 0. \tag{4}$$

The basic phases of the generalized Kudryashov method are explained as follows.

Step 1. First of all, we must get the travelling wave solution of (4) in the following form:

$$u(x, t) = u(\eta), \quad \eta = kx - \frac{\lambda t^\alpha}{\Gamma[1 + \alpha]}, \tag{5}$$

where k and λ are arbitrary constants. Equation (4) was converted into a nonlinear ordinary differential equation of the form

$$N(u, u', u'', u''', \dots) = 0, \tag{6}$$

where the prime indicates differentiation with respect to η .

Step 2. Suggest that the exact solutions of (6) can be written in the following form:

$$u(\eta) = \frac{\sum_{i=0}^N a_i Q^i(\eta)}{\sum_{j=0}^M b_j Q^j(\eta)} = \frac{A[Q(\eta)]}{B[Q(\eta)]}, \tag{7}$$

where Q is $1/(1 \pm e^\eta)$. We note that the function Q is solution of equation [30]:

$$Q_\eta = Q^2 - Q. \tag{8}$$

Taking into consideration (7), we obtain

$$u'(\eta) = \frac{A'Q'B - AB'Q'}{B^2} = Q' \left[\frac{A'B - AB'}{B^2} \right] \tag{9}$$

$$= (Q^2 - Q) \left[\frac{A'B - AB'}{B^2} \right],$$

$$u''(\eta) = \frac{Q^2 - Q}{B^2}$$

$$\times \left[(2Q - 1)(A'B - AB') + \frac{Q^2 - Q}{B} \right.$$

$$\left. \times \left[B(A''B - AB'') - 2B'A'B + 2A(B')^2 \right] \right], \tag{10}$$

$$u'''(\eta)$$

$$= (Q^2 - Q)^3$$

$$\times \left[\left((A'''B - AB''' - 3A''B' - 3B''A')B \right. \right.$$

$$\left. \left. + 6B(AB'' + B'A') \right) (B^3)^{-1} - \frac{6A(B')^3}{B^4} \right] \tag{11}$$

$$+ 3(Q^2 - Q)^2 (2Q - 1)$$

$$\times \left[\frac{B(A''B - AB'') - 2B'A'B + 2A(B')^2}{B^3} \right]$$

$$+ (Q^2 - Q)(6Q^2 - 6Q + 1) \left[\frac{A'B - AB'}{B^2} \right].$$

Step 3. Under the terms of proposed method, we suppose that the solution of (6) can be explained in the following form:

$$u(\eta) = \frac{a_0 + a_1Q + a_2Q^2 + \dots + a_NQ^N + \dots}{b_0 + b_1Q + b_2Q^2 + \dots + b_MQ^M + \dots}. \quad (12)$$

To calculate the values M and N in (12) that is the pole order for the general solution of (6), we progress conformably as in the classical Kudryashov method on balancing the highest-order nonlinear terms in (6) and we can determine a formula of M and N . We can receive some values of M and N .

Step 4. Replacing (7) into (6) provides a polynomial $R(\Omega)$ of Ω . Establishing the coefficients of $R(\Omega)$ to zero, we acquire a system of algebraic equations. Solving this system, we can describe λ and the variable coefficients of $a_0, a_1, a_2, \dots, a_N, b_0, b_1, b_2, \dots, b_M$. In this way, we attain the exact solutions to (6).

3. Applications to the Time-Fractional Equations

In this chapter, we search the exact solutions of time-fractional Burgers equation, time-fractional Cahn-Hilliard equation, and time-fractional generalized third-order KdV by using the generalized Kudryashov method.

Example 1. We take the travelling wave solutions of (1) and we use the transformation $u(x, t) = u(\eta)$ and $\eta = kx - (\lambda t^\alpha / \Gamma[1 + \alpha])$, where k and λ are constants. Then, integrating this equation with respect to η and putting the integration constant to zero, we acquire

$$-\lambda u - k^2 u' - \beta k \frac{u^{p+1}}{p+1} = 0. \quad (13)$$

When we take into consideration the transformation

$$u(\eta) = v^{1/p}(\eta), \quad (14)$$

we obtain the following formula:

$$\lambda p(p+1)v - k^2(p+1)v' - \beta p k v^2 = 0. \quad (15)$$

Setting (7) and (9) into (15) and balancing the highest-order nonlinear terms of v' and v^2 in (15), then the following relation is attained:

$$N - M + 1 = 2N - 2M \implies N = M + 1. \quad (16)$$

If we choose $M = 1$ and $N = 2$, then

$$u(\eta) = \frac{a_0 + a_1Q + a_2Q^2}{b_0 + b_1Q}, \quad (17)$$

$$\begin{aligned} u'(\eta) &= (Q^2 - Q) \\ &\times \left[\frac{(a_1 + 2a_2Q)(b_0 + b_1Q) - b_1(a_0 + a_1Q + a_2Q^2)}{(b_0 + b_1Q)^2} \right], \end{aligned}$$

$$\begin{aligned} u''(\eta) &= \frac{Q^2 - Q}{(b_0 + b_1Q)^2} (2Q - 1) \\ &\times \left[(a_1 + 2a_2Q)(b_0 + b_1Q) - b_1(a_0 + a_1Q + a_2Q^2) \right] \\ &+ \frac{(Q^2 - Q)^2}{(b_0 + b_1Q)^3} \\ &\times \left[2a_2(b_0 + b_1Q)^2 - 2b_1(a_1 + 2a_2Q)(b_0 + b_1Q) \right. \\ &\quad \left. + 2b_1^2(a_0 + a_1Q + a_2Q^2) \right], \\ u'''(\eta) &= (Q^2 - Q)(6Q^2 - 6Q + 1) \\ &\times \left[\frac{(a_1 + 2a_2Q)(b_0 + b_1Q) - b_1(a_0 + a_1Q + a_2Q^2)}{(b_0 + b_1Q)^2} \right] \\ &+ 3(Q^2 - Q)^2(2Q + 1) \\ &\times \left[(2a_2(b_0 + b_1Q)^2 - 2b_1(a_1 + 2a_2Q)(b_0 + b_1Q) \right. \\ &\quad \left. + 2b_1^2(a_0 + a_1Q + a_2Q^2))((b_0 + b_1Q)^3)^{-1} \right] \\ &+ (Q^2 - Q)^3 \\ &\times \left[\frac{-6a_2b_1(b_0 + b_1Q) + 6b_1^2(a_1 + 2a_2Q)}{(b_0 + b_1Q)^3} \right. \\ &\quad \left. - \frac{6b_1^3(a_0 + a_1Q + a_2Q^2)}{(b_0 + b_1Q)^4} \right]. \end{aligned} \quad (18)$$

The exact solutions of (1) are obtained as follows.

Case 1. Consider

$$\begin{aligned} a_0 &= 0, & a_2 &= 0, \\ b_1 &= -\frac{\beta p a_1}{k(1+p)} - b_0, & \lambda &= \frac{k^2}{p}. \end{aligned} \quad (19)$$

When we substitute (19) into (17), we get the following solution of (1):

$$\begin{aligned} v_1(x, t) &= \left(a_1 \left(\frac{1}{1 \pm e^{kx - (k^2 t^\alpha / p \Gamma(1 + \alpha))}} \right) \right) \\ &\times \left(b_0 - \left(\frac{\beta p a_1}{k(1+p)} + b_0 \right) \left(\frac{1}{1 \pm e^{kx - (k^2 t^\alpha / p \Gamma(1 + \alpha))}} \right) \right)^{-1}. \end{aligned} \quad (20)$$

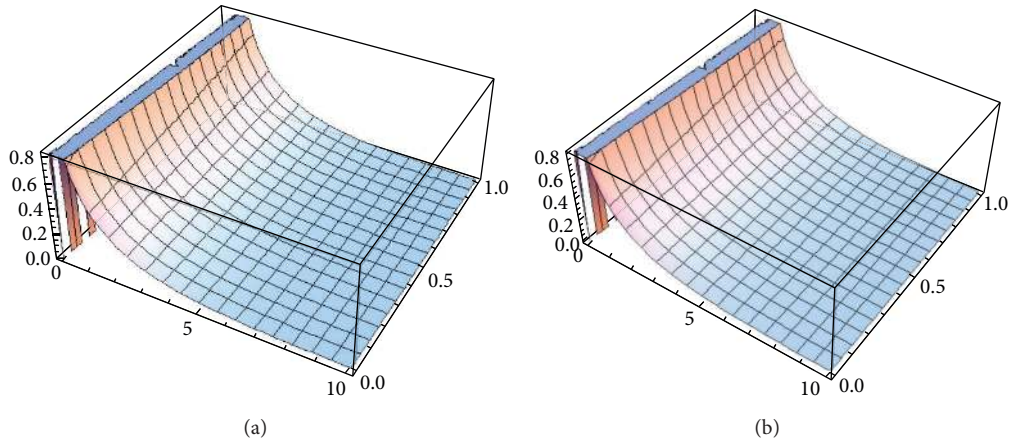

FIGURE 1: Graph of the solution (21) corresponding to the values $\alpha = 0.05, \alpha = 0.85$, respectively, when $k = 1, p = 2, a_1 = 1, b_0 = 2, \beta = 3, 0 < x < 10$, and $0 < t < 1$.

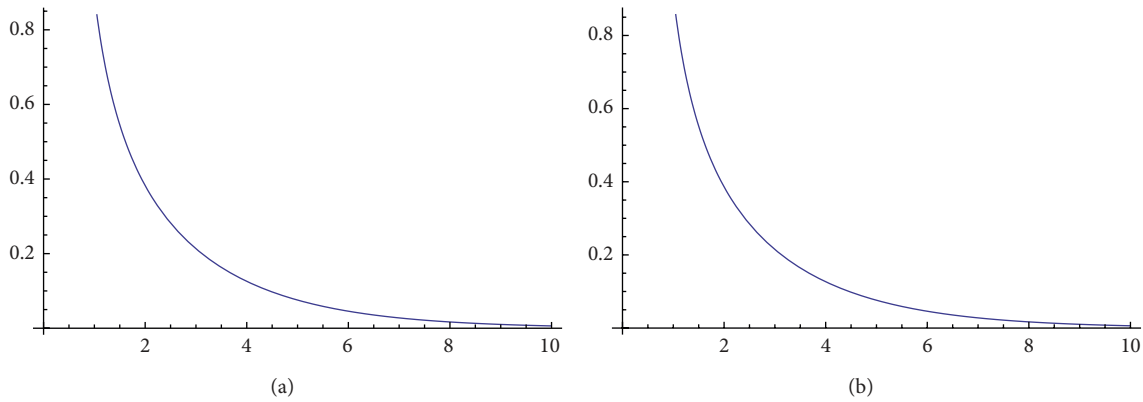

FIGURE 2: Two-dimensional graph of the solution (21) corresponding to the values $\alpha = 0.05, \alpha = 0.85$, respectively, when $k = 1, p = 2, a_1 = 1, b_0 = 2, \beta = 3, t = 1$, and $0 < x < 10$.

Using several simple transformations to this solution, we procure new exact solutions to (1):

$$u_1(x, t) = \left[\frac{1 - \tanh(k_1 x - \lambda_1 t^\alpha)}{K [1 + \tanh(k_1 x - \lambda_1 t^\alpha)] + L [1 - \tanh(k_1 x - \lambda_1 t^\alpha)]} \right]^{1/p}, \tag{21}$$

$$u_2(x, t) = \left[\frac{1 - \coth(k_1 x - \lambda_1 t^\alpha)}{K [1 + \coth(k_1 x - \lambda_1 t^\alpha)] + L [1 - \coth(k_1 x - \lambda_1 t^\alpha)]} \right]^{1/p}, \tag{22}$$

where $K = b_0/a_1, L = -\beta p/k(1 + p), k_1 = k/2$, and $\lambda_1 = k^2/2p\Gamma(1 + \alpha)$.

Case 2. Consider

$$a_0 = \frac{k(1 + p)b_0}{\beta p}, \quad a_1 = \frac{-k(a + p)b_0}{\beta p}, \tag{23}$$

$$a_2 = 0, \quad \lambda = -\frac{k^2}{p}.$$

When we set (23) into (17), we attain the following solution of (1):

$$v_2(x, t) = \left(\frac{k(1 + p)b_0}{\beta p} - \frac{k(1 + p)b_0}{\beta p} \left(\frac{1}{1 \pm e^{kx + (k^2 t^\alpha)/p\Gamma(1 + \alpha)}} \right) \right) \times \left(b_0 + b_1 \left(\frac{1}{1 \pm e^{kx + (k^2 t^\alpha)/p\Gamma(1 + \alpha)}} \right) \right)^{-1}. \tag{24}$$

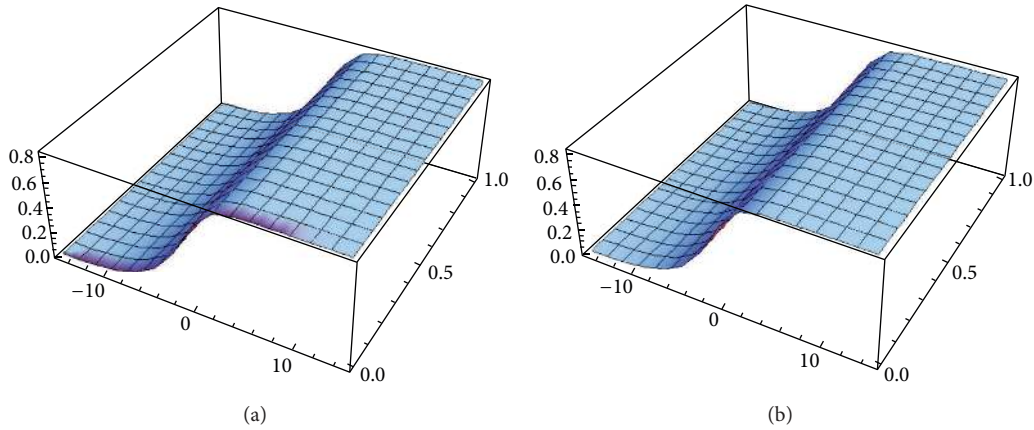

FIGURE 3: Graph of the solution (25) corresponding to the values $\alpha = 0.05, \alpha = 0.85$, respectively, when $k = 1, p = 3, b_0 = 3, b_1 = 1, \beta = 2, -15 < x < 15$, and $0 < t < 1$.

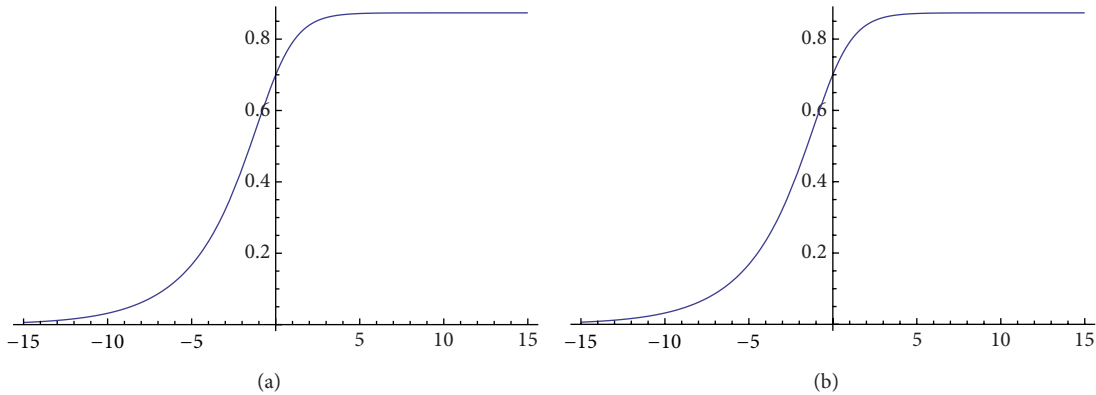

FIGURE 4: Two-dimensional graph of the solution (25) corresponding to the values $\alpha = 0.05, \alpha = 0.85$, respectively, when $k = 1, p = 3, b_0 = 3, b_1 = 1, \beta = 2, t = 1$, and $-15 < x < 15$.

Performing several simple transformations to this solution, we obtain new exact solutions to (1):

$$u_3(x, t) = \left[\frac{M \left[(1/2) + (1/2) \tanh(k_1 x - \lambda_2 t^\alpha) \right]}{b_0 + b_1 \left[(1/2) - (1/2) \tanh(k_1 x - \lambda_2 t^\alpha) \right]} \right]^{1/p} \quad (25)$$

$$u_4(x, t) = \left[\frac{M \left[(1/2) + (1/2) \coth(k_1 x - \lambda_2 t^\alpha) \right]}{b_0 + b_1 \left[(1/2) - (1/2) \coth(k_1 x - \lambda_2 t^\alpha) \right]} \right]^{1/p} \quad (26)$$

where $M = k(1 + p)b_0/\beta p$ and $\lambda_2 = -k^2/2p\Gamma(1 + \alpha)$.

Case 3. Consider

$$\begin{aligned} a_0 = 0, \quad a_1 = 0, \quad a_2 = \frac{-k(1 + p)b_1}{\beta p}, \\ b_0 = \frac{-b_1}{2}, \quad \lambda = \frac{2k^2}{p}. \end{aligned} \quad (27)$$

When we set (27) into (17), we obtain the following solution of (1):

$$\begin{aligned} v_3(x, t) &= \left(\frac{-k(1 + p)b_1}{\beta p} \left(\frac{1}{1 \pm e^{kx - (2k^2 t^\alpha / p\Gamma(1 + \alpha))}} \right)^2 \right) \\ &\times \left(-\frac{b_1}{2} + b_1 \left(\frac{1}{1 \pm e^{kx - (2k^2 t^\alpha / p\Gamma(1 + \alpha))}} \right) \right)^{-1}. \end{aligned} \quad (28)$$

Performing several simple transformations to this solution, we find new exact solutions to (1):

$$u_5(x, t) = \left[\frac{E \left[(1/2) - (1/2) \tanh(k_1 x - \lambda_3 t^\alpha) \right]^2}{\tanh(k_1 x - \lambda_3 t^\alpha)} \right]^{1/p} \quad (29)$$

$$u_6(x, t) = \left[\frac{E \left[(1/2) - (1/2) \coth(k_1 x - \lambda_3 t^\alpha) \right]^2}{\coth(k_1 x - \lambda_3 t^\alpha)} \right]^{1/p} \quad (30)$$

where $E = 2k(1 + p)/\beta p$ and $\lambda_3 = k^2/p\Gamma(1 + \alpha)$.

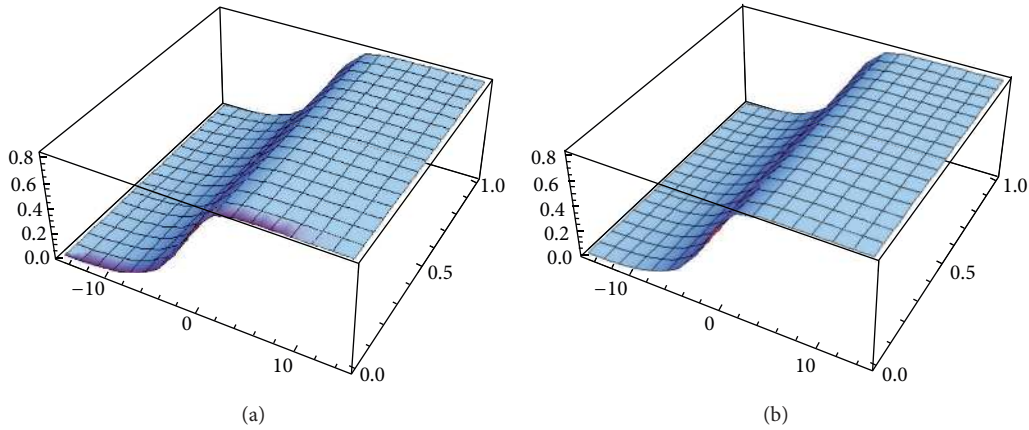

FIGURE 5: Graph of the solution (29) corresponding to the values $\alpha = 0.05, \alpha = 0.85$, respectively, when $k = 1, p = 1, \beta = 4, -15 < x < 15$, and $0 < t < 1$.

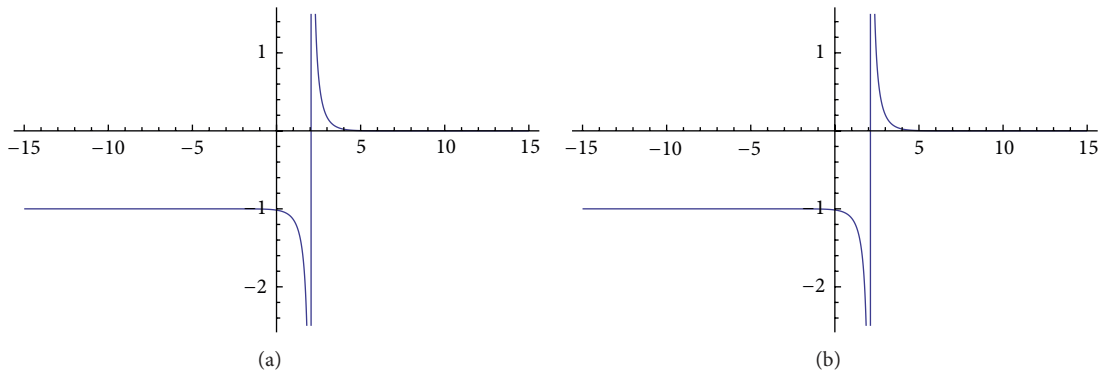

FIGURE 6: Two-dimensional graph of the solution (29) corresponding to the values $\alpha = 0.05, \alpha = 0.85$, respectively, when $k = 1, p = 1, \beta = 4, t = 1$, and $-15 < x < 15$.

Case 4. Consider

$$\begin{aligned}
 a_0 &= 0, & a_1 &= \frac{k(1+p)b_1}{2\beta p}, & a_2 &= \frac{-k(1+p)b_1}{\beta p}, \\
 b_0 &= \frac{-b_1}{2}, & \lambda &= \frac{k^2}{p}.
 \end{aligned}
 \tag{31}$$

When we embed (31) into (17), we get the following solution of (1):

$$\begin{aligned}
 v_4(x, t) &= \left(\frac{k(1+p)b_1}{2\beta p} \left(\frac{1}{1 \pm e^{kx - (k^2 t^\alpha / p \Gamma(1+\alpha))}} \right) \right. \\
 &\quad \left. - \frac{k(1+p)b_1}{\beta p} \left(\frac{1}{1 \pm e^{kx - (k^2 t^\alpha / p \Gamma(1+\alpha))}} \right)^2 \right) \\
 &\quad \times \left(-\frac{b_1}{2} + b_1 \left(\frac{1}{1 \pm e^{kx - (k^2 t^\alpha / p \Gamma(1+\alpha))}} \right) \right)^{-1}.
 \end{aligned}
 \tag{32}$$

Implementing several simple transformations to this solution, we gain kink solutions to (1):

$$u_7(x, t) = [N(1 - \tanh(k_1 x - \lambda_1 t^\alpha))]^{1/p}, \tag{33}$$

$$u_8(x, t) = [N(1 - \coth(k_1 x - \lambda_1 t^\alpha))]^{1/p}, \tag{34}$$

where $N = -k(1+p)/2\beta p$.

Case 5. Consider

$$\begin{aligned}
 a_0 &= \frac{2k(1+p)b_0}{\beta p}, & a_1 &= \frac{-4k(1+p)b_0}{\beta p}, \\
 a_2 &= \frac{2k(1+p)b_0}{\beta p}, & b_1 &= -2b_0, & \lambda &= \frac{-2k^2}{p}.
 \end{aligned}
 \tag{35}$$

When we replace (35) into (17), we reach the following solution of (1):

$$\begin{aligned}
 v_5(x, t) &= \left(\frac{2k(1+p)b_0}{\beta p} - \frac{4k(1+p)b_0}{\beta p} \left(\frac{1}{1 \pm e^{kx + (2k^2 t^\alpha / p \Gamma(1+\alpha))}} \right) \right)
 \end{aligned}$$

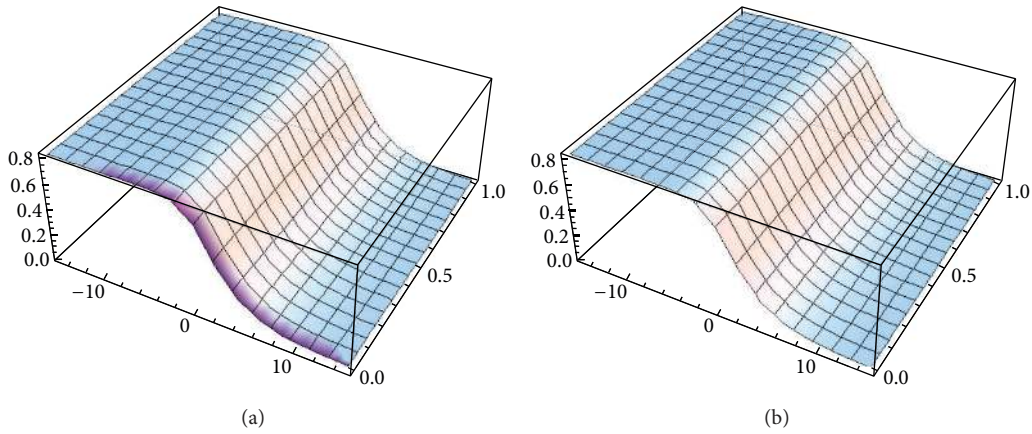

FIGURE 7: Graph of the solution (33) corresponding to the values $\alpha = 0.05, \alpha = 0.85$, respectively, when $k = 1, p = 3, \beta = -2, -15 < x < 15$, and $0 < t < 1$.

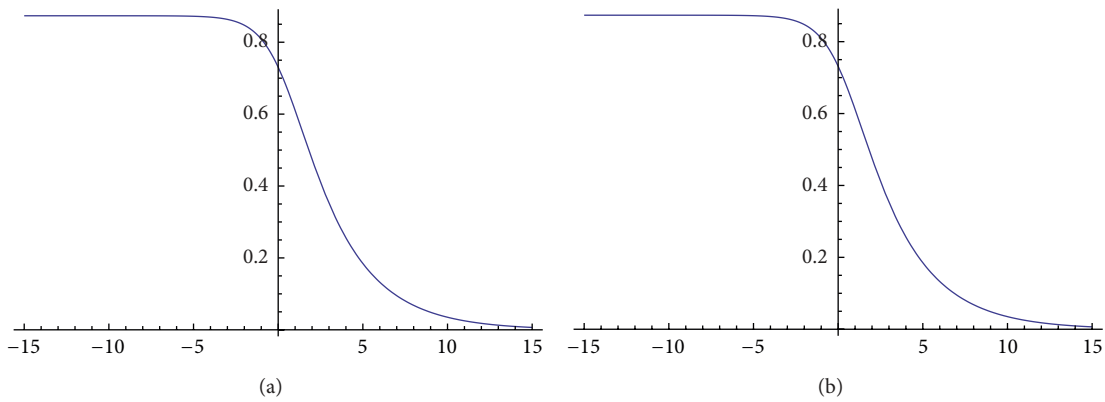

FIGURE 8: Two dimensional graph of the solution (33) corresponding to the values $\alpha = 0.05, \alpha = 0.85$, respectively, when $k = 1, p = 3, \beta = -2, t = 1$, and $-15 < x < 15$.

$$\begin{aligned}
 & + \frac{2k(1+p)b_0}{\beta p} \left(\frac{1}{1 \pm e^{kx+(2k^2t^\alpha/p\Gamma(1+\alpha))}} \right)^2 \\
 & \times \left(b_0 - 2b_0 \left(\frac{1}{1 \pm e^{kx+(2k^2t^\alpha/p\Gamma(1+\alpha))}} \right) \right)^{-1}.
 \end{aligned}
 \tag{36}$$

Applying several simple transformations to this solution, we attain new exact solutions to (1):

$$u_9(x, t) = \left[\frac{E[(1/2) + (1/2) \tanh(k_1x - \lambda_4t^\alpha)]^2}{\tanh(k_1x - \lambda_4t^\alpha)} \right]^{1/p},
 \tag{37}$$

$$u_{10}(x, t) = \left[\frac{E[(1/2) + (1/2) \coth(k_1x - \lambda_4t^\alpha)]^2}{\coth(k_1x - \lambda_4t^\alpha)} \right]^{1/p},
 \tag{38}$$

where $\lambda_4 = -k^2/p\Gamma(1 + \alpha)$.

Case 6. Consider

$$\begin{aligned}
 a_0 &= \frac{k(1+p)b_0}{\beta p}, & a_1 &= \frac{-3k(1+p)b_0}{\beta p}, \\
 a_2 &= \frac{2k(1+p)b_0}{\beta p}, & b_1 &= -2b_0, & \lambda &= \frac{-k^2}{p}.
 \end{aligned}
 \tag{39}$$

When we put (39) into (17), we have the following solution of (1):

$$\begin{aligned}
 v_6(x, t) &= \left(\frac{k(1+p)b_0}{\beta p} - \frac{3k(1+p)b_0}{\beta p} \left(\frac{1}{1 \pm e^{kx+(k^2t^\alpha/p\Gamma(1+\alpha))}} \right) \right. \\
 & \quad \left. + \frac{2k(1+p)b_0}{\beta p} \left(\frac{1}{1 \pm e^{kx+(k^2t^\alpha/p\Gamma(1+\alpha))}} \right)^2 \right) \\
 & \quad \times \left(b_0 - 2b_0 \left(\frac{1}{1 \pm e^{kx+(k^2t^\alpha/p\Gamma(1+\alpha))}} \right) \right)^{-1}.
 \end{aligned}
 \tag{40}$$

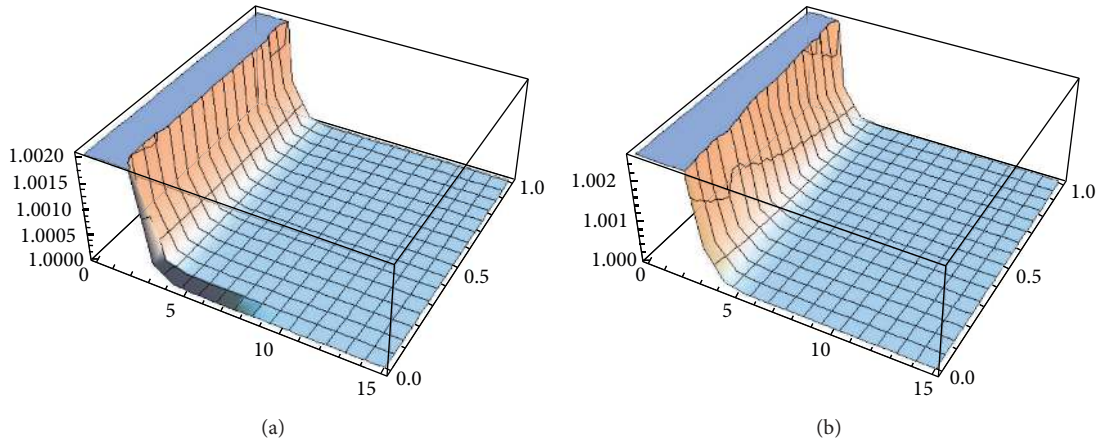

FIGURE 9: Graph of the solution (37) corresponding to the values $\alpha = 0.05, \alpha = 0.85$, respectively, when $k = 1, p = 2, \beta = 3, 0 < x < 15$, and $0 < t < 1$.

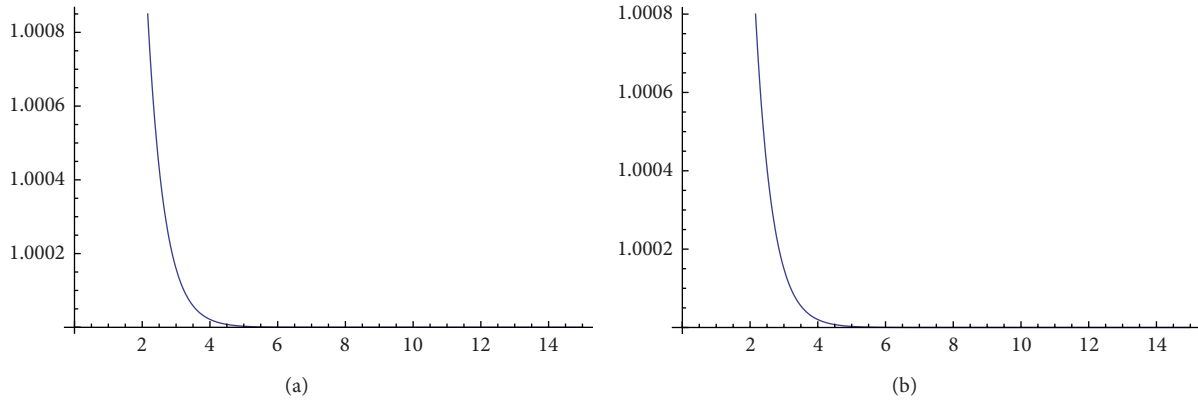

FIGURE 10: Two-dimensional graph of the solution (37) corresponding to the values $\alpha = 0.05, \alpha = 0.85$, respectively, when $k = 1, p = 2, \beta = 3, t = 1$, and $0 < x < 15$.

Fulfilling several simple transformations to this solution, we acquire kink solutions to (1):

$$u_{11}(x, t) = [D(1 + \tanh(k_1x - \lambda_2t^\alpha))]^{1/p}, \quad (41)$$

$$u_{12}(x, t) = [D(1 + \coth(k_1x - \lambda_2t^\alpha))]^{1/p}, \quad (42)$$

where $D = k(1 + p)/2\beta p$.

Remark 2. The exact solutions of (1) were found by using generalized Kudryashov method and have been checked by means of Mathematica Release 9. Comparing our results with results in [16, 22], then we can say that exact solutions of (1) that we obtained in this paper were firstly presented to the literature. Also, the advantage of our method compared to other methods in [16, 22] is to give more exact solutions.

Example 3. We take the travelling wave solutions of (2) and we implement the transformation $u(x, t) = u(\eta)$ and $\eta = kx - (\lambda t^\alpha/\Gamma(1 + \alpha))$, where k and λ are constants. Then, integrating

this equation with respect to η and embedding the integration constant to zero, we obtain

$$(\lambda + k)u + 3k^2u^2u' - k^2u' - k^4u''' = 0. \quad (43)$$

Putting (7), (9), and (11) into (43) and balancing the highest-order nonlinear terms of u''' and u^2u' in (43), then the following formula is procured:

$$N - M + 3 = 3N - 3M + 1 \implies N = M + 1. \quad (44)$$

In an attempt to obtain exact solutions of (2), if we take

$$a_1 = \frac{a_0 \left[-(1 + k^2)b_0 + \sqrt{(1 + k^2)(-3a_0^2 + (1 + k^2)b_0^2)} \right]}{(1 + k^2)b_0},$$

$$a_2 = 0,$$

$$b_1 = -b_0 + \frac{\sqrt{(1 + k^2)(-3a_0^2 + (1 + k^2)b_0^2)}}{(1 + k^2)},$$

$$\lambda = -k,$$

(45)

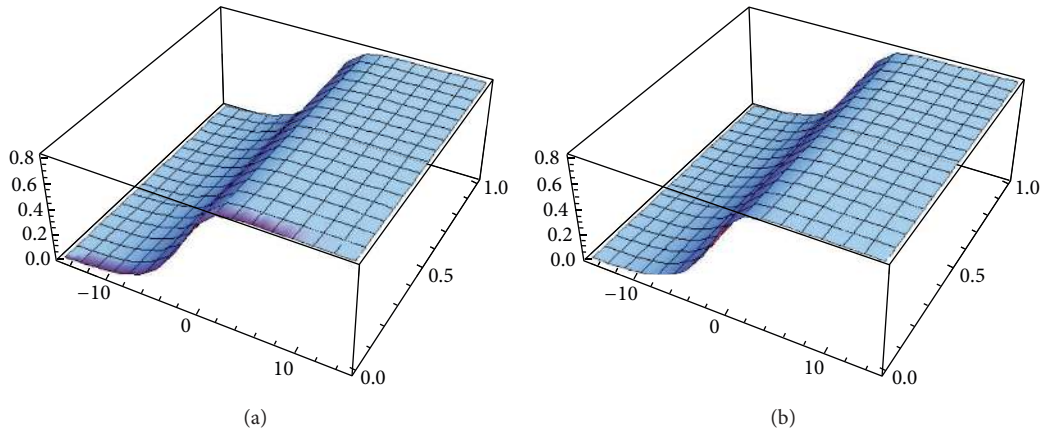

FIGURE 11: Graph of the solution (41) corresponding to the values $\alpha = 0.05, \alpha = 0.85$, respectively, when $k = 1, p = 3, \beta = 2, -15 < x < 15$, and $0 < t < 1$.

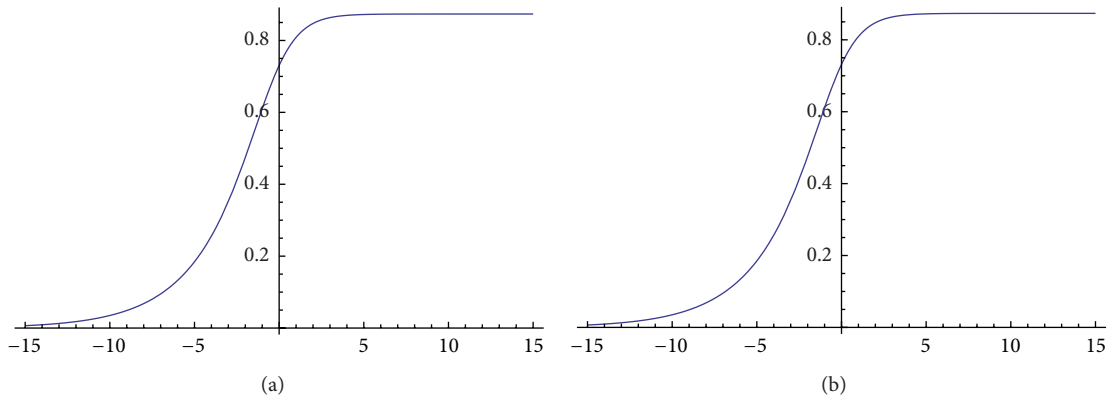

FIGURE 12: Two-dimensional graph of the solution (41) corresponding to the values $\alpha = 0.05, \alpha = 0.85$, respectively, when $k = 1, p = 3, \beta = 2, t = 1$, and $-15 < x < 15$.

and put (45) into (17), we obtain the following solution of (2):

$$\begin{aligned}
 u(x, t) &= \left(a_0 + \left(a_0 \left[-(1+k^2)b_0 + \sqrt{(1+k^2)(-3a_0^2 + (1+k^2)b_0^2)} \right] \right. \right. \\
 &\quad \times \left. \left. \left(\frac{1}{1 \pm e^{kx + (kt^\alpha/\Gamma(1+\alpha))}} \right) \right) \left((1+k^2)b_0 \right)^{-1} \right) \\
 &\quad \times \left(b_0 + \left[-b_0 + \frac{\sqrt{(1+k^2)(-3a_0^2 + (1+k^2)b_0^2)}}{(1+k^2)} \right] \right. \\
 &\quad \times \left. \left. \left(\frac{1}{1 \pm e^{kx + (kt^\alpha/\Gamma(1+\alpha))}} \right) \right)^{-1}. \tag{46}
 \end{aligned}$$

Fulfilling several simple transformations to this solution, we get new exact solutions to (2):

$$u_1(x, t) = P \left[\frac{1 + 1 \tanh(k_1 x - \lambda_5 t^\alpha)}{1 - \tanh(k_1 x - \lambda_5 t^\alpha)} \right] + R, \tag{47}$$

$$u_2(x, t) = P \left[\frac{1 + 1 \coth(k_1 x - \lambda_5 t^\alpha)}{1 - \coth(k_1 x - \lambda_5 t^\alpha)} \right] + R, \tag{48}$$

where $P = a_0 \sqrt{(1+k^2)/(-3a_0^2 + (1+k^2)b_0^2)}$, $R = a_0/b_0$, and $\lambda_5 = -k/2\Gamma(1+\alpha)$.

Remark 4. The solutions given by (47) and (48) of (2) were attained by using the generalized Kudryashov method and have been controlled by means of Mathematica Release 9. If we compare our results with results in [24], then it is clear that the exact solutions of (2) that we obtained in this paper were firstly introduced to the literature.

Example 5. We get the travelling wave solutions of (3) and we apply the transformation $u(x, t) = u(\eta)$ and $\eta = kx - (\lambda t^\alpha/\Gamma(1+\alpha))$, where k and λ are constants. Then, integrating

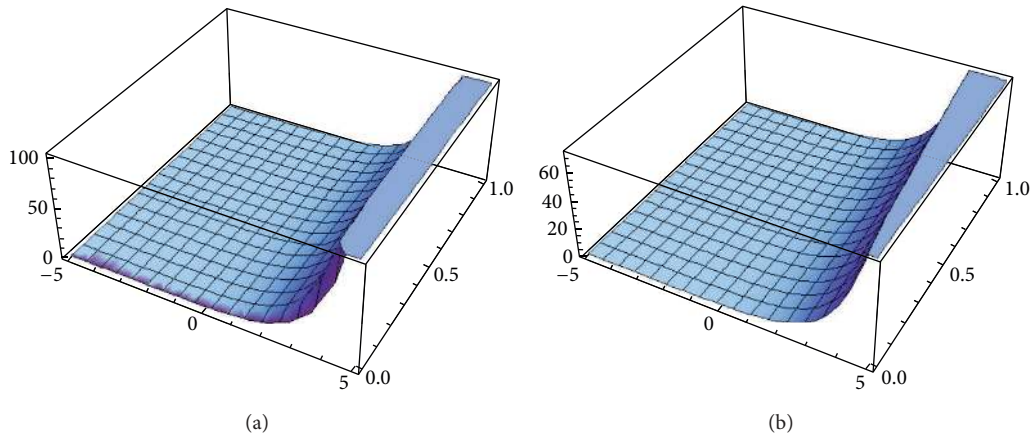

FIGURE 13: Graph of the solution (47) corresponding to the values $\alpha = 0.05, \alpha = 0.85$, respectively, when $k = 1, a_0 = 1, b_0 = 2, -5 < x < 5$, and $0 < t < 1$.

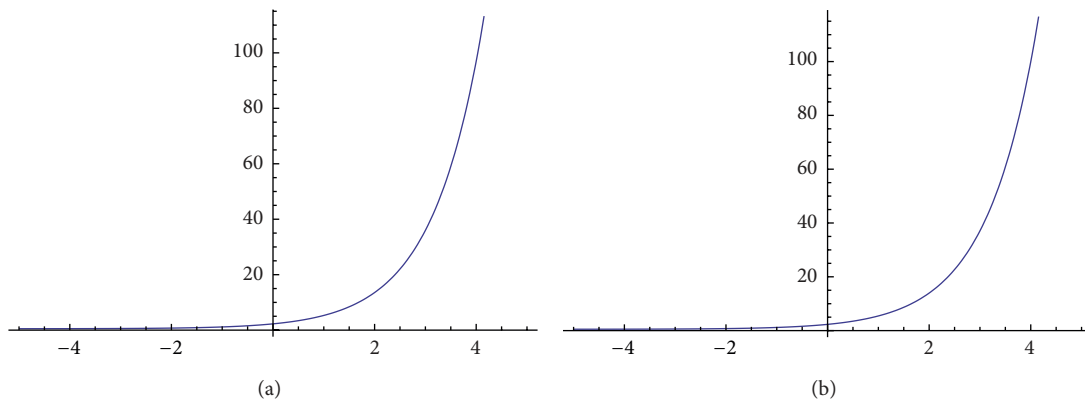

FIGURE 14: Two-dimensional graph of the solution (47) corresponding to the values $\alpha = 0.05, \alpha = 0.85$, respectively, when $k = 1, a_0 = 1, b_0 = 2, t = 1$, and $-5 < x < 5$.

this equation with respect to η and setting the integration constant to zero, we attain

$$\lambda(p+1)u + k^3(p+1)u'' + \gamma k \frac{u^{p+1}}{p+1} = 0. \quad (49)$$

When we take into consideration the transformation

$$u(\eta) = v^{1/p}(\eta), \quad (50)$$

we find the following formula:

$$\lambda p^2(p+1)v^2 + k^3(1-p^2)(v')^2 + k^3 p(p+1)vv'' + \gamma kv^3 = 0. \quad (51)$$

Setting (7) and (10) into (51) and balancing the highest-order nonlinear terms of vv'' and v^3 in (51), then the following relation is attained:

$$2N - 2M + 2 = 3N - 3M + 1 \implies N = M + 2. \quad (52)$$

If we take $M = 1$ and $N = 3$, then

$$u(\eta) = \frac{a_0 + a_1Q + a_2Q^2 + a_3Q^3}{b_0 + b_1Q}, \quad (53)$$

$$\begin{aligned} u'(\eta) &= (Q^2 - Q) \\ &\times \left[\left((a_1 + 2a_2Q + 3a_3Q^2)(b_0 + b_1Q) - b_1(a_0 + a_1Q + a_2Q^2 + a_3Q^3) \right) \times ((b_0 + b_1Q)^2)^{-1} \right], \end{aligned}$$

$$\begin{aligned} u''(\eta) &= \frac{Q^2 - Q}{(b_0 + b_1Q)^2} (2Q - 1) \\ &\times \left[(a_1 + 2a_2Q + 3a_3Q^2)(b_0 + b_1Q) \right] \end{aligned}$$

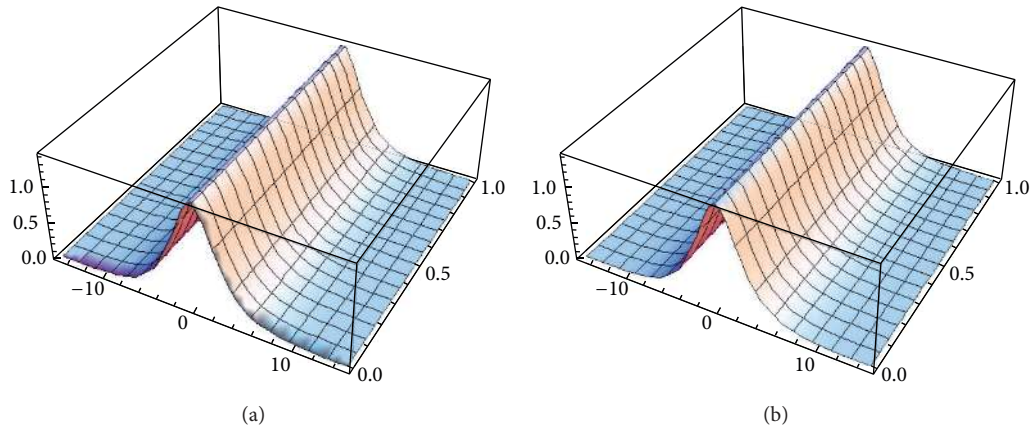

FIGURE 15: Graph of the solution (57) corresponding to the values $\alpha = 0.05$, $\alpha = 0.85$, respectively, when $k = 1$, $p = 2$, $\gamma = 3$, $-15 < x < 15$, and $0 < t < 1$.

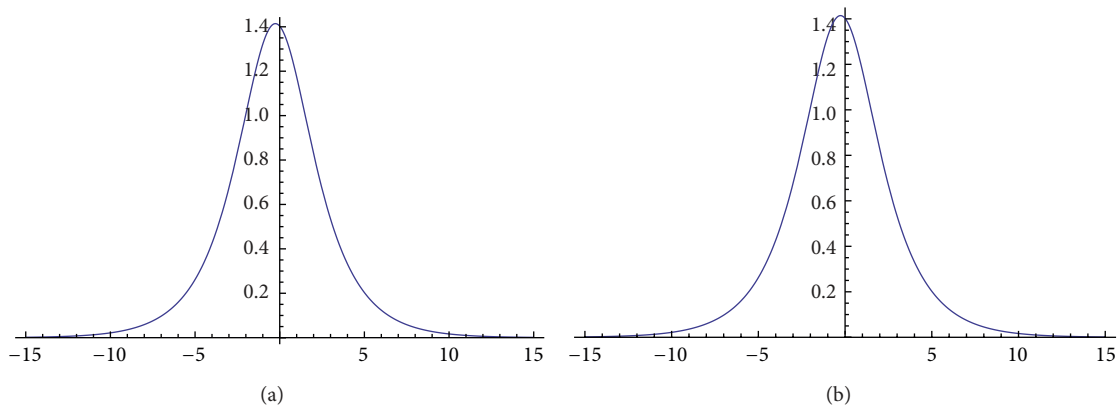

FIGURE 16: Two-dimensional graph of the solution (57) corresponding to the values $\alpha = 0.05$, $\alpha = 0.85$, respectively, when $k = 1$, $p = 2$, $\gamma = 3$, $t = 1$, and $-15 < x < 15$.

$$\begin{aligned}
 & -b_1(a_0 + a_1Q + a_2Q^2 + a_3Q^3)] \\
 & + \frac{(Q^2 - Q)^2}{(b_0 + b_1Q)^3} \\
 & \times \left[(b_0 + b_1Q)^2(2a_2 + 6a_3Q) \right. \\
 & \quad - 2b_1(b_0 + b_1Q)(a_1 + 2a_2Q + 3a_3Q^2) \\
 & \quad \left. + 2b_1^2(a_0 + a_1Q + a_2Q^2 + a_3Q^3) \right].
 \end{aligned}
 \tag{54}$$

In an attempt to find the exact solution of (3), if we choose

$$\begin{aligned}
 a_0 &= 0, & a_1 &= \frac{2k^2(1+p)(2+p)b_0}{\gamma}, \\
 a_2 &= -\frac{2k^2(1+p)(2+p)(b_0 - b_1)}{\gamma}, \\
 a_3 &= -\frac{2k^2(1+p)(2+p)b_1}{\gamma}, & \lambda &= -\frac{k^3}{p^2},
 \end{aligned}
 \tag{55}$$

and embed (55) into (53), we obtain the following solution of (3):

$$\begin{aligned}
 v(x, t) &= \left(\frac{2k^2(1+p)(2+p)b_0}{\gamma} \left(\frac{1}{1 \pm e^{kx + (k^3t^\alpha/p^2)\Gamma(1+\alpha)}} \right) \right. \\
 & \quad - \frac{2k^2(1+p)(2+p)(b_0 - b_1)}{\gamma} \left(\frac{1}{1 \pm e^{kx + (k^3t^\alpha/p^2)\Gamma(1+\alpha)}} \right)^2 \\
 & \quad \left. - \frac{2k^2(1+p)(2+p)b_1}{\gamma} \left(\frac{1}{1 \pm e^{kx + (k^3t^\alpha/p^2)\Gamma(1+\alpha)}} \right)^3 \right) \\
 & \quad \times \left(b_0 + b_1 \left(\frac{1}{1 \pm e^{kx + (k^3t^\alpha/p^2)\Gamma(1+\alpha)}} \right) \right)^{-1}.
 \end{aligned}
 \tag{56}$$

Performing several simple transformations to this solution, we get kink solutions to (3):

$$u_1(x, t) = [S(1 - [\tanh(k_1x - \lambda_6t^\alpha)])^2]^{1/p}, \tag{57}$$

$$u_2(x, t) = \left[S \left(1 - [\coth(k_1 x - \lambda_6 t^\alpha)]^2 \right) \right]^{1/p}, \quad (58)$$

where $S = k^2(1+p)(2+p)/2\gamma$ and $\lambda_6 = -k^3/2p^2\Gamma(1+\alpha)$.

Remark 6. The solutions given by (57) and (58) of (3) were gained by using the generalized Kudryashov method and have been checked by means of Mathematica Release 9. Comparing our results with results in [14, 22], it can be seen that the exact solutions of (3) that we obtained in this paper were firstly submitted to the literature.

We plot solution (21) of (1) in Figures 1-2, solution (25) of (1) in Figures 3-4, solution (29) of (1) in Figures 5-6, solution (33) of (1) in Figures 7-8, solution (37) of (1) in Figures 9-10, solution (41) of (1) in Figures 11-12, which show the dynamics of solutions with suitable parametric choices. Then we plot solution (47) of (2) in Figures 13-14, which show the dynamics of solutions with suitable parametric choices. Finally we plot solution (57) of (3) in Figures 15-16, which show the dynamics of solutions with suitable parametric choices.

4. Conclusion

The Kudryashov method provides us with the evidential manner to constitute solitary wave solutions for a large category of nonlinear partial differential equations. Previously, many authors have tackled Kudryashov method. But, in this paper, we construct generalized form of Kudryashov method. This type of method will be newly considered in the literature to generate exact solutions of nonlinear fractional differential equations.

According to this information, we can conclude that GKM has an important role to find analytical solutions of nonlinear fractional differential equations. Also, we emphasize that this method is substantially influential and reliable in terms of finding new hyperbolic function solutions. We think that this method can also be implemented in other nonlinear fractional differential equations.

Conflict of Interests

The authors declare that there is no conflict of interests regarding the publication of this paper.

References

- [1] J. M. Burgers, "A mathematical model illustrating the theory of turbulence," *Advances in Applied Mechanics*, vol. 1, pp. 171-199, 1948.
- [2] J. W. Cahn and J. E. Hilliard, "Free energy of a nonuniform system. I. Interfacial free energy," *The Journal of Chemical Physics*, vol. 28, no. 2, pp. 258-267, 1958.
- [3] A. Novick-Cohen, "The Cahn-Hilliard equation," in *Handbook of Differential Equations, Evolutionary Equations*, vol. 4, Haifa, Israel, Elsevier, 2008.
- [4] D. J. Korteweg and G. de Vries, "On the change of form of long waves advancing in a rectangular canal and on a new type of long stationary waves," *Philosophical Magazine*, vol. 39, pp. 422-443, 1895.
- [5] M. K. Fung, "KdV equation as an Euler-Poincare'equation," *Chinese Journal of Physics*, vol. 35, no. 6, pp. 789-796, 1997.
- [6] K. S. Miller and B. Ross, *An Introduction to the Fractional Calculus and Fractional Differential Equations*, Wiley, New York, NY, USA, 1993.
- [7] A. A. Kilbas, H. M. Srivastava, and J. Trujillo, *Theory and Applications of Fractional Differential Equations*, Elsevier Science, New York, NY, USA, 2006.
- [8] I. Podlubny, *Fractional Differential Equations*, Academic Press, San Diego, Calif, USA, 1999.
- [9] X.-J. Yang, D. Baleanu, Y. Khan, and S. T. Mohyud-din, "Local fractional variational iteration method for diffusion and wave equations on cantor sets," *Romanian Journal of Physics*, vol. 59, no. 1-2, pp. 36-48, 2014.
- [10] X.-J. Yang and D. Baleanu, "Fractal heat conduction problem solved by local fractional variation iteration method," *Thermal Science*, vol. 17, no. 2, pp. 625-628, 2013.
- [11] X. J. Yang, H. M. Srivastava, J. H. He, and D. Baleanu, "Cantor-type cylindrical-coordinate method for differential equations with local fractional derivatives," *Physics Letters A*, vol. 377, no. 28-30, pp. 1696-1700, 2013.
- [12] X.-J. Yang, D. Baleanu, and J. He, "Transport equations in fractal porous media within fractional complex transform method," *Proceedings of the Romanian Academy A: Mathematics, Physics, Technical Sciences, Information Science*, vol. 14, no. 4, pp. 287-292, 2013.
- [13] A. Atangana, S. T. Demiray, and H. Bulut, "Modelling the nonlinear wave motion within the scope of the fractional calculus," *Abstract and Applied Analysis*, vol. 2014, Article ID 481657, 7 pages, 2014.
- [14] Y. Pandir, Y. Gurefe, and E. Misirli, "The extended trial equation method for some time fractional differential equations," *Discrete Dynamics in Nature and Society*, Article ID 491359, 13 pages, 2013.
- [15] Y. Pandir, "New exact solutions of the generalized Zakharov-Kuznetsov modified equal width equation," *Pramana*, vol. 82, no. 6, pp. 949-964, 2014.
- [16] H. Bulut, H. M. Baskonus, and Y. Pandir, "The modified trial equation method for fractional wave equation and time fractional generalized Burgers equation," *Abstract and Applied Analysis*, vol. 2013, Article ID 636802, 8 pages, 2013.
- [17] Y. Pandir and Y. A. Tandogan, "Exact solutions of the time-fractional Fitzhugh-Nagumo equation," in *Proceedings of the 11th International Conference on Numerical Analysis and Applied Mathematics*, vol. 1558 of *AIP Conference Proceedings*, pp. 1919-1922, 2013.
- [18] Y. Pandir, Y. Gurefe, and E. Misirli, "A multiple extended trial equation method for the fractional Sharma-Tasso-Olver equation," in *Proceedings of the 11th International Conference of Numerical Analysis and Applied Mathematics (ICNAAM '13)*, vol. 1558 of *AIP Conference Proceedings*, pp. 1927-1930, 2013.
- [19] H. Bulut, Y. Pandir, and H. M. Baskonus, "Symmetrical hyperbolic Fibonacci function solutions of generalized Fisher equation with fractional order," *AIP Conference Proceedings*, vol. 1558, pp. 1914-1918, 2013.
- [20] Y. A. Tandogan, Y. Pandir, and Y. Gurefe, "Solutions of the nonlinear differential equations by use of modified Kudryashov method," *Turkish Journal of Mathematics and Computer Science*, Article ID 20130021, 7 pages, 2013.
- [21] Y. Pandir, "Symmetric fibonacci function solutions of some nonlinear partial differential equations," *Applied Mathematics Information Sciences*, vol. 8, no. 5, pp. 2237-2241, 2014.

- [22] R. Sahadevan and T. Bakkyaraj, “Invariant analysis of time fractional generalized Burgers and Korteweg-de Vries equations,” *Journal of Mathematical Analysis and Applications*, vol. 393, no. 2, pp. 341–347, 2012.
- [23] A. Bekir, Ö. Güner, and A. C. Cevikel, “Fractional complex transform and exp-function methods for fractional differential equations,” *Abstract and Applied Analysis*, vol. 2013, Article ID 426462, 8 pages, 2013.
- [24] Z. Dahmani and M. Benbachir, “Solutions of the Cahn-Hilliard equation with time- and space-fractional derivatives,” *International Journal of Nonlinear Science*, vol. 8, no. 1, pp. 19–26, 2009.
- [25] H. Jafari, H. Tajadodi, N. Kadkhoda, and D. Baleanu, “Fractional subequation method for Cahn-Hilliard and Klein-Gordon equations,” *Abstract and Applied Analysis*, vol. 2013, Article ID 587179, 5 pages, 2013.
- [26] J. Hu, Y. Ye, S. Shen, and J. Zhang, “Lie symmetry analysis of the time fractional KdV-type equation,” *Applied Mathematics and Computation*, vol. 233, pp. 439–444, 2014.
- [27] Y. Zhang, “Formulation and solution to time-fractional generalized Korteweg-de Vries equation via variational methods,” *Advances in Difference Equations*, vol. 2014, article 65, 12 pages, 2014.
- [28] S. A. El-Wakil, E. M. Abulwafa, and M. A. Zahran, “Time-fractional KdV equation: formulation and solution using variational methods,” *Nonlinear Dynamics*, vol. 65, no. 1-2, pp. 55–63, 2011.
- [29] G. W. Wang, T. Z. Xu, and T. Feng, “Lie symmetry analysis and explicit solutions of the time fractional fifth-order KdV equation,” *PLoS ONE*, vol. 9, no. 2, Article ID e88336, 2014.
- [30] N. A. Kudryashov, “One method for finding exact solutions of nonlinear differential equations,” *Communications in Nonlinear Science and Numerical Simulation*, vol. 17, no. 6, pp. 2248–2253, 2012.
- [31] J. Lee and R. Sakthivel, “Exact travelling wave solutions for some important nonlinear physical models,” *Pramana—Journal of Physics*, vol. 80, no. 5, pp. 757–769, 2013.
- [32] P. N. Ryabov, D. I. Sinelshchikov, and M. B. Kochanov, “Application of the Kudryashov method for finding exact solutions of the high order nonlinear evolution equations,” *Applied Mathematics and Computation*, vol. 218, no. 7, pp. 3965–3972, 2011.



Hindawi

Submit your manuscripts at
<http://www.hindawi.com>

