

**Iowa State University**

---

**From the Selected Works of R. Bruce Thompson**

---

1979

Generation of horizontally polarized shear waves  
in ferromagnetic materials using  
magnetostrictively coupled meander-coil  
electromagnetic transducers

R. Bruce Thompson



Available at: [https://works.bepress.com/rbruce\\_thompson/38/](https://works.bepress.com/rbruce_thompson/38/)

## Generation of horizontally polarized shear waves in ferromagnetic materials using magnetostrictively coupled meandercoil electromagnetic transducers

R. Bruce Thompson

Citation: *Appl. Phys. Lett.* **34**, 175 (1979); doi: 10.1063/1.90719

View online: <http://dx.doi.org/10.1063/1.90719>

View Table of Contents: <http://apl.aip.org/resource/1/APPLAB/v34/i2>

Published by the [American Institute of Physics](http://www.aip.org).

---

### Related Articles

Giant magnetoelectric effect in mechanically mediated composite structure of TbFe<sub>2</sub> alloy and Pb(Zr,Ti)O<sub>3</sub> ceramics

*J. Appl. Phys.* **113**, 114504 (2013)

Tailoring of the soft magnetic property and uniaxial anisotropy of magnetostrictive films by interlayer

*J. Appl. Phys.* **113**, 17A309 (2013)

The effect of magnetic annealing on the magnetostriction for Sm-Dy-Fe rod alloys

*J. Appl. Phys.* **113**, 17A905 (2013)

Microstructures and magnetostrictive strains of Fe-Ga-Ni ferromagnetic shape memory alloys

*J. Appl. Phys.* **113**, 17A303 (2013)

Magnetoelectric effects in functionally graded multiferroic bilayers

*J. Appl. Phys.* **113**, 084502 (2013)

---

### Additional information on *Appl. Phys. Lett.*

Journal Homepage: <http://apl.aip.org/>

Journal Information: [http://apl.aip.org/about/about\\_the\\_journal](http://apl.aip.org/about/about_the_journal)

Top downloads: [http://apl.aip.org/features/most\\_downloaded](http://apl.aip.org/features/most_downloaded)

Information for Authors: <http://apl.aip.org/authors>

## ADVERTISEMENT

**JANIS** Does your research require low temperatures? Contact Janis today.  
Our engineers will assist you in choosing the best system for your application.



10 mK to 800 K      LHe/LN<sub>2</sub> Cryostats  
Cryocoolers      Magnet Systems  
Dilution Refrigerator Systems  
Micro-manipulated Probe Stations

[sales@janis.com](mailto:sales@janis.com)      [www.janis.com](http://www.janis.com)  
Click to view our product web page.

# Generation of horizontally polarized shear waves in ferromagnetic materials using magnetostrictively coupled meander-coil electromagnetic transducers

R. Bruce Thompson

Rockwell International Science Center, Thousand Oaks, California 91360  
(Received 24 July 1978; accepted for publication 6 November 1978)

A new electromagnetic transducer configuration is described for generating horizontally polarized shear (SH) waves in ferromagnetic materials. The transducer consists of a meander coil and static bias magnetic field parallel to the coil elements. This configuration generates no ultrasonic waves in a nonmagnetic metal since the induced eddy currents are parallel to the bias field and the driving Lorentz forces vanish. However, the configuration provides coupling to SH waves in ferromagnetic materials through magnetostrictive effects. Experimental measurements of the variation of transduction efficiency with bias field in nickel and 4130 steel plate are presented and compared to the efficiency obtained with the same meander coils when the bias is rotated 90° in the plane of the plate so that antisymmetric Lamb waves are generated. Peak efficiencies occur at considerably different bias fields for the two configurations. This result, as well as other features in the data, are interpreted in terms of a simple model.

PACS numbers: 75.80.+q, 43.88.Dv, 62.30.+d

The use of electromagnetic-acoustic transducers (EMAT's) to excite and detect ultrasonic waves has recently received considerable attention because of the ability to operate without a couplant.<sup>1,2</sup> A transducer consists of a coil of wire driven at a dynamic frequency  $\omega$  and a magnet (either permanent or electromagnet) producing a static bias field  $H_0$ . When placed next to a nonmagnetic metal at room temperature, ultrasonic waves are launched as a response to the Lorentz body force

$$\mathbf{f} = \mu_0 \mathbf{J}_\omega \times \mathbf{H}_0, \quad (1)$$

where  $\mathbf{J}_\omega$  is the dynamic eddy current induced in the metal by the coil. Waves can be detected by the same structure through reciprocal processes.

A variety of coil-magnet configurations have been developed to couple to particular elastic wave modes or polarizations.<sup>1,2</sup> In nonmagnetic metals it is desired to arrange the geometry so that the induced eddy currents are perpendicular to the static bias field, so that the maximum force can be developed. For example, one of the widest used transducer types is the meander coil, which is shown in Fig. 1(a). This can be used to excite Rayleigh waves,<sup>3</sup> Lamb waves,<sup>3</sup> or angle shear or longitudinal beams,<sup>4</sup> depending upon the particular drive frequency chosen. A second type of transducer, the periodic permanent magnet EMAT, can excite the orthogonally polarized horizontal shear (SH) plate or bulk modes.<sup>5,6</sup> Both of these transducers, as other previous versions, have been designed for operation on nonmagnetic metals on the basis of the Lorentz driving forces. However, they operate on ferromagnetic materials as well, and, for the meander-coil case with bias field parallel to the direction of propagation, magnetostriction has been identified as a dominant mechanism.<sup>7,8</sup>

This letter describes a new transducer configuration for generating SH waves. The basic structure is shown in Fig. 1(b). The meander coil used is the same as before, but the static bias field is parallel to the wire elements so that the

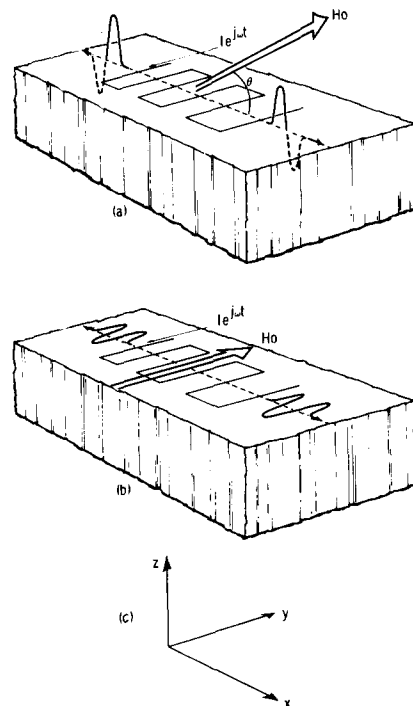
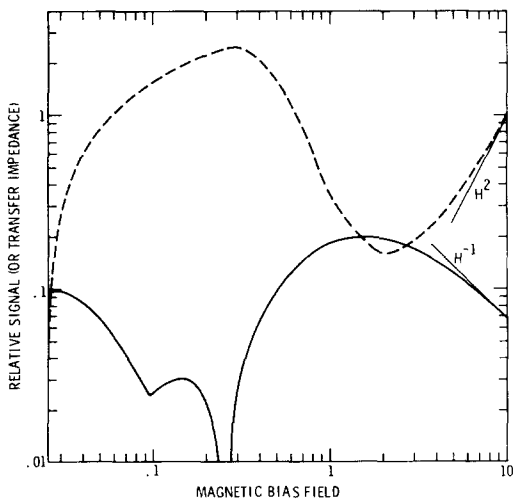

FIG. 1. Meander-coil EMAT's with various bias field directions. (a) Configuration for generating Rayleigh, Lamb, or angle SV beams. Magnetic field is in the sagittal plane. (b) Configuration for generating horizontally polarized shear waves. Magnetic field is parallel to coil elements. (c) Coordinate system.

Lorentz force vanishes. The transducer, therefore, differs from previous transducers not only in detail but in basic principle, since no generation occurs in the nonmagnetic limit. It is only through magnetostrictive forces that the generation can occur in ferromagnetic materials.

This generation is illustrated in Fig. 2, where the field dependence of the amplitude of the signal transmitted between a pair of transducers is plotted for two ferromagnetic materials. Also shown for comparison is the signal produced in the configuration of Fig. 1(a) when  $\theta=0$ . The experiments were performed on 1.6-mm-thick ( $\frac{1}{16}$  in.) plates of nickel and 4130 steel. The meander coil had a period of 0.305 cm (0.120 in.) as required for Rayleigh-wave excitation at approximately 1 MHz on a half-space. In the configuration shown in



(a)

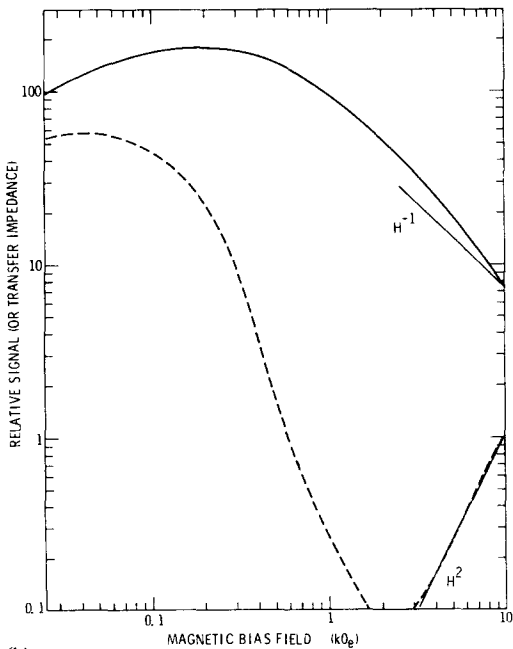

(b)

FIG. 2. Variation of ultrasonic signal transmitted between a pair of transducers for configurations shown in Fig. 1 (a) (dashed line) and Fig. 1(b) (heavy solid line). The light solid lines are high field limits for the SH transducer which varies as  $H_0^{-1}$  and for the Lamb-wave transducer which varies as  $H_0^2$ . (a) 4130 steel. (b) nickel.

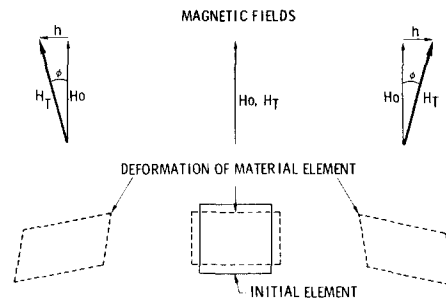

FIG. 3. Sketch of magnetostrictively induced lattice deformation responsible for generation of SH waves as it varies during one-half cycle of drive. Solid lines indicated the deformation of an originally square element that occurs at high fields in a material, such as polycrystalline iron or nickel, with negative magnetostriction.

Fig. 1(a), maximum transmission between the transducer pairs occurred at 0.84 MHz, as expected for excitation of the  $A_0$  plate mode. In the configuration of Fig. 1(b), maximum transmission occurred at 1.04 MHz, substantiating that the  $SH_0$  mode was, in fact, excited with a phase velocity of  $3.2 \times 10^5$  cm/sec, equal to that of a bulk shear mode in these materials. The relative efficiencies of the two mechanisms are approximately maintained in the figures. The new configuration is more efficient than the previous one in nickel, while it is somewhat less efficient in steel.

For the configuration shown in Fig. 1(a), the magnetostrictive contribution to the transduction efficiency has been analyzed in detail.<sup>7,8</sup> This is not the case for the presently reported transducer, and will be the subject of a future paper. However, the basic physical principles are believed to be understood at this time. In the coordinate system shown in Fig. 1(c), it can be seen that the magnetic fields consist of a dynamic component  $h_x$  superimposed on a static bias  $H_{oy}$ . Consider, for simplicity, the high-bias case,  $H_{oy} > 1$  kOe, where the material is close to saturation. The magnetization changes by reversible rotations<sup>10</sup> and will essentially follow the vector sum of these fields. It, therefore, oscillates in the  $xy$  plane about the  $y$  axis. In this limit, both nickel and steel (polycrystalline) tend to shorten in the direction of magnetization.<sup>11</sup> As the field and magnetization rotates, the material tends to shorten along their instantaneous direction. Consequently, a deformation (contraction) of the material is also rotating in the  $xy$  plane as shown in Fig. 3. Under dynamic conditions, this may be described by stresses  $\sigma_{xy}$  which, when coupled with the periodicity induced in the  $x$  direction by the meander coil, will produce an effective body force  $f_y$  in accordance with the relation

$$f_y = \frac{\partial}{\partial x} \sigma_{xy} \quad (2)$$

The SH waves are launched as a response of this force.

Without presenting a detailed analysis, it is possible to explain two prominent features of the data. As in the case where the dynamic and static fields are parallel ( $\theta=0^\circ$ ), it can be shown that the amplitude of the ultrasonic wave transmitted between a pair of these transducers is proportional to  $[\delta(\partial\sigma_{xy}/\partial h_x)]^2$ , where  $\delta$  is the electromagnetic skin

depth, proportional to  $\mu^{-1/2}$  with  $\mu$  being the magnetic permeability, and  $\partial\sigma_{xy}/\partial h_x$  is a magnetostrictive coefficient for the crossed-field case. In the domain rotation regime near saturation, it is well known that  $\mu \simeq [1 + (M_0/H_{0y})]$ ,<sup>12</sup> where  $M_0$  is the magnetization produced by the bias. By similar arguments, it can be shown that  $\partial\sigma_{xy}/\partial h_x \simeq C_{44}(\Delta 1/1)_0/H_{0y}$ , where  $C_{44}$  is the shear modulus and  $(\Delta 1/1)_0$  is the magnetostriction produced by the bias. At high bias, it follows that the ultrasonic signal should vary as  $H_{0y}^{-1}$ . This was, in fact, observed experimentally as indicated by the solid asymptotes in Fig. 2.

Second, these arguments suggest that the strength of the signal in this new configuration should be proportional to  $(\Delta 1/1)_0^2/H_{0y}^2$ , whereas in the previous configuration it was proportional to  $[\partial(\Delta 1/1)_0/\partial H_0]^2$ .<sup>2,8</sup> This is substantiated by the data in Fig. 2. In 4130 steel, the maximum efficiency point for the  $\theta = 0$  configuration occurs when  $h_{ox} = 300$  Oe. At this bias,  $\partial(\Delta 1/1)_0/\partial H_0$  is large, but the absolute value of  $(\Delta 1/1)_0$  can be quite small<sup>11</sup> under many metallurgical conditions. The small transduction efficiency in the new configuration is probably the result of such a case. For higher or lower bias levels,  $(\Delta 1/1)_0$  increases in magnitude but  $\partial(\Delta 1/1)_0/\partial H_0$  diminishes. This is reflected by proportional changes in transduction efficiency. The results in nickel are simpler since there is less structure in the magnetostrictive curve. However, again the peak efficiency is observed at different bias levels for the two configurations, for similar reasons.

It is interesting to note that the newer configuration has a greater efficiency than the previous configuration in nickel and a lower efficiency in steel. This is in agreement with preliminary attempts to quantify the above discussion and will be discussed in a future paper.

It is believed that this new transducer has many potential applications in the excitation of SH waves for both signal processing and nondestructive testing devices. These waves

are important because of the absence of mode conversion when they strike surfaces parallel to their polarization and the resulting simplicity of the resulting signals. Previously they could only be excited by EMAT's using the periodic permanent magnet geometry.<sup>5,6</sup> The new transducer allows one to use an electromagnet to reach one of the high-efficiency points shown in Fig. 2. Such a bias variation is quite difficult using the periodic permanent magnet transducer. Also, the dynamically driven meander coil has practical advantages over the dynamically driven solenoidal coil used with the periodic magnetic transducer because it has a lower impedance level, which is easier to drive with solid-state circuitry, and because it does not strongly radiate electromagnetic energy, thereby reducing shielding and leakage problems.

The author would like to acknowledge several useful discussions, which helped clarify ideas presented in this paper, with Dr. C. F. Vasile and Dr. C. M. Fortunko of this laboratory. This work was supported by the Independent Research and Development Program of the Rockwell International Science Center.

<sup>1</sup>R. Bruce Thompson 1977 *Ultrasonics Symposium Proceedings*, Cat. No. 77CH 1264-1 SV (IEEE New York, 1977), p. 74.

<sup>2</sup>H. M. Frost, in *Physical Acoustics*, Vol. 14, edited by W. P. Mason and R. N. Thurston (Academic, New York, to be published).

<sup>3</sup>R. Bruce Thompson, *IEEE Trans. Sonics Ultrason.* **SU-20**, 340 (1973).

<sup>4</sup>T. J. Moran and R. M. Panos, *J. Appl. Phys.* **47**, 2225 (1976).

<sup>5</sup>C. F. Vasile and R. B. Thompson, Ref. 1, p. 84.

<sup>6</sup>C. F. Vasile and R. B. Thompson, *J. Appl. Phys.* **50**, XXXX (1979).

<sup>7</sup>R. Bruce Thompson, *J. Appl. Phys.* **48**, 4942 (1977).

<sup>8</sup>R. Bruce Thompson, *IEEE Trans. Sonics Ultrason.* **SU-25**, (1978).

<sup>9</sup>B. A. Auld, *Acoustic Fields and Waves in Solids*, Vol. II (Wiley-Interscience, New York, 1973), Chap. 10, p. 63.

<sup>10</sup>R. M. Bozorth, *Ferromagnetism* (Van Nostrand, Princeton, N. J., 1951), Chap. 11, p. 476ff.

<sup>11</sup>R. M. Bozorth, *Ferromagnetism* (Van Nostrand, Princeton, N. J., 1951), Chap. 11, pp. 655ff.

<sup>12</sup>C. Kittel, *Introduction to Solid State Physics* (Wiley, New York, 1956), p. 413.