

VU Research Portal

Genetic and Environmental Influences on the Development of Intelligence

Bartels, M.; Rietveld, M.J.H.; van Baal, G.C.M.; Boomsma, D.I.

published in

Behavior Genetics
2002

DOI (link to publisher)

[10.1023/A:1019772628912](https://doi.org/10.1023/A:1019772628912)

document version

Publisher's PDF, also known as Version of record

[Link to publication in VU Research Portal](#)

citation for published version (APA)

Bartels, M., Rietveld, M. J. H., van Baal, G. C. M., & Boomsma, D. I. (2002). Genetic and Environmental Influences on the Development of Intelligence. *Behavior Genetics*, 32(4), 237-249.
<https://doi.org/10.1023/A:1019772628912>

General rights

Copyright and moral rights for the publications made accessible in the public portal are retained by the authors and/or other copyright owners and it is a condition of accessing publications that users recognise and abide by the legal requirements associated with these rights.

- Users may download and print one copy of any publication from the public portal for the purpose of private study or research.
- You may not further distribute the material or use it for any profit-making activity or commercial gain
- You may freely distribute the URL identifying the publication in the public portal ?

Take down policy

If you believe that this document breaches copyright please contact us providing details, and we will remove access to the work immediately and investigate your claim.

E-mail address:

vuresearchportal.ub@vu.nl

Genetic and Environmental Influences on the Development of Intelligence

M. Bartels,^{1,2} M. J. H. Rietveld,¹ G. C. M. Van Baal,¹ and D. I. Boomsma¹

Received 11 Jan. 2002—Final 24 Apr. 2002

Measures of intelligence were collected in 209 twin pairs at 5, 7, 10, and 12 years of age, as part of a longitudinal project on intelligence, brain function, and behavioral problems. Intelligence was measured at 5, 7, and 10 years of age with the RAKIT, a well-known Dutch intelligence test, consisting of 6 subscales. At 12 years of age, the complete WISC-R was administered (12 subscales). Both intelligence tests resulted in a measure of full-scale IQ (FSIQ). Participation rate is around 93% at age 12. Correlation coefficients over time are high: $r(5-7) = .65$; $r(5-10) = .65$; $r(5-12) = .64$; $r(7-10) = .72$; $r(7-12) = .69$ and $r(10-12) = .78$. Genetic analyses show significant heritabilities at all ages, with the expected increase of genetic influences and decrease of shared environmental influences over the years. Genetic influences seem to be the main driving force behind continuity in general cognitive ability, represented by a common factor influencing FSIQ at all ages. Shared environmental influences are responsible for stability as well as change in the development of cognitive abilities, represented by a common factor influencing FSIQ at all ages and age-specific influences, respectively.

KEY WORDS: General cognitive ability; longitudinal analyses; heritability; twin study; simplex.

INTRODUCTION

Heritability of intelligence has been studied extensively, both in adults and in children, but far less is known about the developmental genetics of cognitive abilities. Many behavior genetic studies yield the largely consistent result that genetic differences account for at least 50% of the observed variability in cognition in adults (e.g., Bouchard and McGue, 1981; McCartney *et al.*, 1990; Bratko, 1996; Rijdsdijk *et al.*, 1997, 1998; Alarcón *et al.*, 1998, 1999, Posthuma *et al.*, 2000). It is also well established that the genetic influences on cognitive functioning increase throughout development, whereas influences of common environment decrease (e.g., Skodak and Skeels, 1949; Wilson, 1983; Labuda *et al.*, 1986; Fulker *et al.*, 1988; Loehlin *et al.*, 1989; McCartney *et al.*, 1990; McGue *et al.*,

1993; Boomsma, 1993; Plomin *et al.*, 1997; Boomsma and Van Baal, 1998; Alarcón, 1998, 1999). A few longitudinal studies have focused on the influences of genes and environment on cognitive development rather than cognition at specific ages. New genetic influences at different ages and a common factor for shared environmental influences have been found (Colorado Adoption Project; e.g., Plomin and DeFries, 1985; Louisville Twin Study; e.g., Wilson, 1983; Eaves *et al.*, 1986).

Longitudinal twin and family data allow the study of persistence and change of genetic, shared environmental, and unique environmental influences. The genetic and environmental influences may exert their effects following several possible mechanisms. First, genetic or environmental factors may exert a continuous influences from their time of onset (common factor influences). This mechanism implies that the same genetic or environmental factors are responsible for stability, possibly with age-dependent factor loadings. Second, genetic and environmental influences may be specific at a certain age and exert an effect on cognition at that age

¹ Department of Biological Psychology, Vrije Universiteit, Amsterdam, The Netherlands.

² To whom correspondence should be addressed at Department of Biological Psychology, Vrije Universiteit, room 1F 57, van der Boerhorststraat 1, 1081 BT, Amsterdam, The Netherlands. Fax: +31 20 4448812. e-mail: m.bartels@psy.vu.nl

only. Change in cognitive development may be due to these age specific factors. Finally, there can be a simplex-like continuity in genetic and environmental effects (Eaves *et al.*, 1986; Boomsma and Molenaar, 1987). In this simplex-like continuity, there are effects specific to each age and there are “carry-over effects” or transmission effects from one age to the subsequent age (Fig. 1). In other words, earlier influences may be transmitted from one occasion to the next and new influences (innovations) may come into play at each occasion. Data that are collected from the same subjects repeatedly in time often display this simplex structure for the observed correlations among the measures at different time points. Specifically, it is observed that correlations are highest among adjoining occasions and that they decrease systematically as the distance between time points increases (Guttman, 1954).

Notable longitudinal studies on cognition are the Colorado Adoption Project (CAP) (e.g., Plomin and DeFries, 1985) and the Louisville Twin Study (LTS) (e.g., Wilson, 1983). These studies are more or less comparable to the current study, in which intelligence is assessed longitudinally in twins from age 5 to age 12. We will introduce the CAP and LTS and also mention other studies, which offer an insight in the genetic and environmental patterns that account for variance in cognitive development (for reviews, see also Thompson, 1993; Patrick, 2000).

The CAP is a longitudinal “full” adoption study of behavioral development. The study started in 1975 and included adopted children and their adoptive and biological parents. Children in the sample were tested yearly on age-appropriate cognitive measures. Until now, longitudinal results from 1 to 16 years of age have been published for the CAP. The CAP original sample consisted of 245 adoptive families and 245 nonadoptive control families. In 1999, the CAP sample consisted of 129 adopted individuals tested at 16 years of age and their adoptive and biological parents. The non-adoptive (control) sample included 125 sets of parents and nonadoptive children (Alarcón *et al.*, 1999).

The LTS was initiated in 1957 by Falkner. In the LTS, twins were tested every 3 months in the first year of life. Testing continued at 6-months intervals during second and third year of life, and annually through age 9, with follow-up visits at age 15 and adulthood. In 1983, the sample of the LTS consisted of 494 pairs of twins active in the longitudinal study, ranging in age from 3 months to 15 years. Recruitment has been an ongoing process, with 25–35 pairs added each year since 1963. However, like in every longitudinal design, the study suffers from dropouts over the years.

Sophistication in developmental behavior genetics involves the formulation of models that attempt to describe the etiology of genetic and environmental influences on variation in cognitive development. Phillips

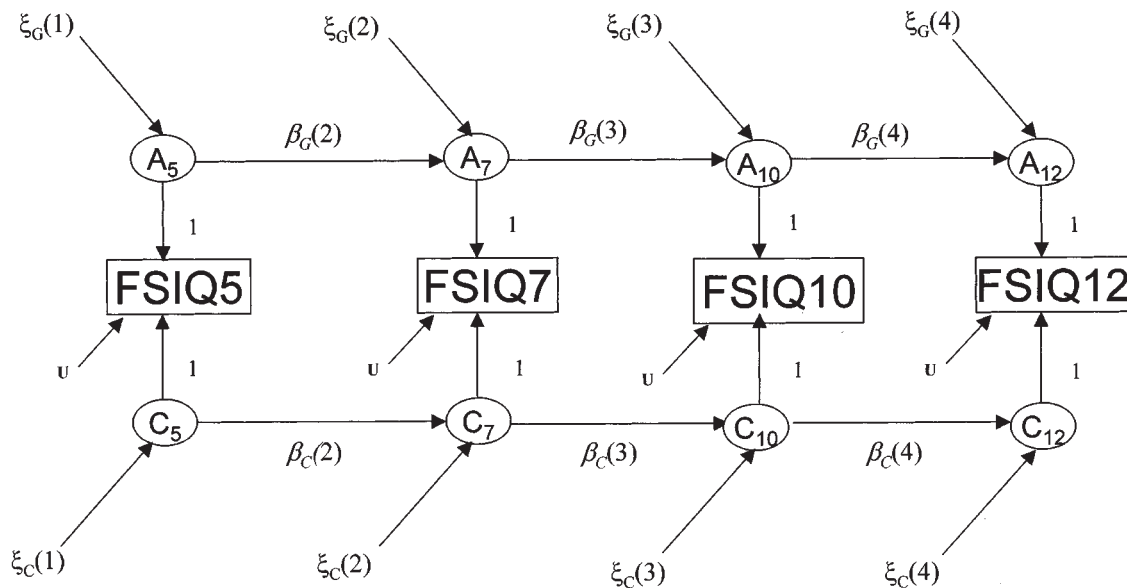

Fig. 1. Simplex model examining developmental pattern of genetic, shared environmental and unique environmental influences on IQ. $\xi_G(t)_4$ are the innovation parameters. $\beta_G(t)$ are the transmission parameters. U are time-specific influences of unique environment.

and Fulker (1989) developed a model, based on a quasi-simplex model presented earlier by Eaves *et al.* (1986), in which it was possible to distinguish between the three possible longitudinal mechanisms (time-specific, common factor, simplex). This model was applied to a large data set combined from several major projects (Cardon *et al.*, 1992). The CAP data at ages 1, 2, 3, 4, and 7 were combined with data from twins at ages 1, 2, and 3 from the MacArthur Longitudinal Twin Study (MLTS) (Plomin *et al.*, 1990) and the Twin Infant Project (TIP) (DiLalla *et al.*, 1990; Benson, *et al.*, 1993). The best model for genetic influences on IQ was a simplex model, with time-specific innovations included. That is, genetic variation initially shown at age 1 is expressed through at least age 7 with new genetic variation, independent of the initial genetic influence, at ages 2, 3, and 7, but not at age 4. For shared environment, the best-fitting model showed only a single common factor influence on IQ, with equal factor loadings at each age. This longitudinal outcome suggests that shared environmental effects contribute to continuity only. In complete contrast is the picture that emerged for unique environment. For unique environment, the influences were specific to each time-point, which implied that change in cognition is, at least partly, accounted for by these influences.

In a subsequent publication involving CAP, TIP, and MLTS subjects, including subjects from the CAP sample at age 9, very similar results were found (Fulker *et al.*, 1993a). This time, a Cholesky decomposition was used. A common genetic factor present at year 1 continued to account for observed variance in IQ, but with diminishing impact with increasing age. Evidence for genetic change at two important developmental transitions was found. The first was transition from infancy to early childhood (ages 2 and 3). The second was the transition from early to middle childhood (age 7). Fulker *et al.* (1993a) speculated that the new genetic influence at age 7 might be in response to the 'novel environmental challenge' of schooling. No new genetic effect was apparent at age 9. Further, there was one continuous source of shared environmental influence across all ages. Application of the quasi-simplex model to the same data yielded identical results (Cherny and Cardon, 1994). Finally, the only longitudinal model-fitting results based on the LTS data showed that a simplex model gave a better fit compared to a common factor model for genetic effects from ages 1 to 9 years (Humphreys and Davey, 1988).

To summarize, the general picture that emerges from these studies with young children is that genetic

effects account both for stability and change in cognitive performance. This is implied by the simplex-like structure with time-specific innovation effects. Shared environmental effects appear to account for stability in intellectual performance, indicated by the single common factor structure, without age-specific effects. Consistent across studies, the unique environment is best modeled as exerting time-specific influences only. This structure implies that the unique environment is important in explaining variance in cognitive performance at each age, but not in explaining stability of cognitive performance across ages.

In the present longitudinal study, structural modeling techniques were used to examine the influences of genetic and environmental factors on development of full-scale IQ (FSIQ), using data of 209 Dutch twin pairs tested at 5, 7, 10, and 12 years of age. In addition to estimating the importance of heritability and environmental influences, the focus was on the developmental pattern of cognition. A genetic simplex model and a common factor model were used to study continuity and changes of genetic and environmental influences over time. Based on previous results of longitudinal studies on the development of cognitive functioning, a simplex structure for genetic influences was expected. Further, it was assumed that shared environmental factors show continuing effects over the years and unique environmental influences are age specific only.

METHODS

Participants

This study is part of an ongoing, longitudinal study of the development of intelligence and problem behavior. The study started in 1992 with recruitment of 209 twin pairs from the Netherlands Twin Register (NTR; Boomsma, Orlebeke, & Van Baal, 1992). The initial sample of 209 twin pairs was selected on the basis of age and zygosity of the twins, and their city of residence. Mean age at the first measurement occasion was 5.3 years (80% ranging from 5 years and 1 month to 5 years and 6 months). At the second measurement occasion, mean age was 6.8 years (80% ranging from 6 years and 6 months to 7 years and 1 month). Mean age at the third measurement occasion was 10 years (80% ranging from 9 years and 11 months to 10 years and 1 month). Mean age at the fourth measurement occasion was 12 years and several days (80% ranging from 11 years and 11 months to 12 years and 1 month). Zygosity of the same-sex twins was established by either

blood group polymorphisms (137 pairs) or DNA analyses (24 pairs) and, in a few pairs, by physical resemblance assessed by the test administrator (9 pairs). There were 47 monozygotic female (MZF), 37 dizygotic female (DZF), 42 monozygotic male (MZM), 44 dizygotic male (DZM), and 39 dizygotic pairs of opposite sex (DOS). The intelligence test was administered to all 209 twin pairs at age 5. At the second measurement occasion (age 7), 192 pairs of the original sample provided complete data on all subtests. The number of participating twin pairs increased to 197 when the children were tested around their 10th birthday. At the fourth measurement occasion (age 12), 192 twin pairs participated. A small group of four families refused consistently to participate after the first measurement occasion. Five families dropped out at ages 10 and 12. The remaining nonparticipants refused participation at one measurement occasion. At ages 5 and 12, one incomplete twin pair can be found in the data because of difficulties during testing (age 5) and refusal to participate (age 12). Because of serious loss of hearing, one twin pair was assigned missing value at all four ages for FSIQ. This left a sample of 176 twin pairs with complete data at all four ages. No significant difference in initial FSIQ (at age 5) has been found for twins who dropped out on one or more of the following occasions ($F_{3, 415} = 2.25, P = .082$). Details on the demographic characteristics of the sample and information on parental occupation can be found in Rietveld *et al.* (2000).

Procedure and Intelligence Tests

At ages 5 and 7 years, the twins participated in a study on the development of cognitive abilities and brain activity (Boomsma and Van Baal, 1998). At both measurement occasions, the twin and their family visited the laboratory at the university. While one of the twins participated in the electrophysiological experiment, the co-twin participated in an intelligence test. At ages 10 and 12 years, a different procedure was followed. The twins and their parents could choose whether they preferred to come to the university or whether they preferred to be visited at home to participate in the intelligence test. The majority of the families (around 70% at both ages) preferred testing at home. No significant difference in FSIQ was observed between children tested at home or at the university. The intelligence test was assessed by an experienced test administrator. At ages 5, 7, and 10, the test took approximately 1 hour to complete, and at age 12 the test took 1 and 1/2 hours to complete. All children received a present afterwards.

At age 5, 7, and 10, the children were tested with the Revised Amsterdamse Kinder Intelligentie Test (RAKIT) (Bleichrodt *et al.*, 1984). Six subtests, with age-appropriate items, were employed to assess cognitive functioning. Raw subtest total scores are corrected for age and transformed into standardized scores with a mean of 15 and a standard deviation of 5. The total IQ score is based on the combination of these transformed subtests with a mean of 100 and standard deviation of 15. The standardization is based on a population sample of Dutch 6- to 11-year-old children. No difference is made for boys and girls. For further details on this well-known Dutch intelligence test see Rietveld *et al.* (2000). At age 12, the twins conducted the complete version of the WISC-R, Dutch version (Van Haasen *et al.*, 1986). The WISC-R consists of 12 subtests, 6 mainly verbal and 6 mainly nonverbal. The subtest scores are standardized, based on results of same-aged children in the Netherlands. No differences are made for boys and girls. Addition of the twelve standardized subtest scores results in FSIQ. The concurrent validity of the RAKIT and the WISC-R is .86 (Pijl *et al.*, 1984).

Statistical Analyses

Descriptive statistics for FSIQ were calculated using SPSS/windows 10. Twin correlations with their 95% confidence intervals at each age have been calculated. These correlations are informative on the importance of genes and environment in explaining observed variance at each age. To assess stability of intelligence, phenotypic cross correlations over time were calculated. MZ and DZ cross correlations over time have been calculated to get a first impression of the genetic and environmental contributions to the covariance over time.

Genetic Modeling

Univariate model fitting procedures were used to estimate genetic and environmental influences at each age separately and to investigate the presence of sex-differences and influences of sex-specific genes in these data. Genetic model fitting of twin data allows for separation of the observed phenotypic variance into its genetic and environmental components. Additive genetic variance (A), is the variance that results from the additive effects of alleles at each contributing genetic locus. Shared environmental variance (C) is the variance that results from environmental events common to both members of a twin pair. Unique environmental variance (E) is the variance that results from environmental effects that are not shared by members of a twin

pair. Estimates of the unique environmental effects also include measurement error. To account for this source of variance, E is always specified in the model.

The different degree of genetic relatedness between monozygotic (MZ) and dizygotic (DZ) twin pairs was used to estimate the contribution of these factors to the phenotypic variation in cognitive abilities. Similarities for MZ twins are assumed to be due to additive genetic influences plus environmental influences that are shared by both members of a twin pair. Experiences that make MZ twins different from one another are unique environmental influences. Because DZ twins share 50% of their genetic material on average, like other siblings, genetic factors contribute only half to their resemblance. As for MZ twins the shared environment contributes fully. Model fitting to twin data is based on the comparison of the variance-covariance matrices in MZ and DZ twins. Exploiting the known difference in genetic contribution to intrapair resemblance of MZ and DZ twin pairs and the influences of additive genetic, shared environmental and unique environmental factors are estimated using the computer program Mx.

Differences between boys and girls can occur in two ways. First, a difference in the magnitude of additive genetic, shared environmental and unique environmental influences can exist, represented in a distinct pattern of twin correlations for boys and girls. Second, heterogeneity, an expression of different genes in boys and girls, can occur. This heterogeneity would be represented by a lower twin correlation in dizygotic twins of opposite sex in comparison to dizygotic same sex twins. Differences in magnitude of additive genetic, shared environmental and unique environmental influences is tested by the change in fit after constraining the parameter estimates equal for boys and girls. Testing for heterogeneity is accomplished by testing the genetic correlations between two members of a dizygotic twin of opposite sex. Normally the genetic correlation of DZ twins is fixed at .5. Heterogeneity would result in a genetic correlation of less than .5.

Multivariate genetic model fitting techniques were used to obtain insight in the developmental pattern of cognitive functioning and to obtain estimates of the genetic and environmental influences on cognitive development. Parameters were estimated by maximum likelihood, using the computer program Mx (Neale *et al.*, 1999). Rather than decomposing the variance of a measurement into genetic and environmental sources of variance, multivariate genetic analysis decomposes the variance of each measurement occasion and the covariance between the measurement occasions into genetic and environmental sources. The total variances and covariances

were decomposed into additive genetic (A), shared environmental (C), and unique environmental (E) parts. First, to get an initial insight in the variance and covariance structure a Cholesky decomposition model was applied to the data. Next, to investigate the stability and change in FSIQ a genetic simplex model was applied to the data. For each source of variance (A, C, and E) a simplex structure was specified. A simplex model is a first-order autoregressive process. In the simplex model, covariances among the four ages of measurement are specified by genetic and environmental factors specific to each age and by 'carry-over effects' or transmission of these factors to subsequent ages. The model specifies the variance unique to each measurement occasion by an innovation term that comes into play at each time point. The variance is a product of the age-specific effects and age-to-age transmission effect (see appendix 1 and Fig. 1). Finally, it was investigated whether a common factor, possibly with age-dependent factor loadings and age-specific influences, could replace the simplex structure for genetic and shared environmental influences.

To make optimal use of all available data, analyses were performed on the raw data. Submodels were compared by hierarchic χ^2 tests. The χ^2 statistic is computed by subtracting $-2LL$ for the full model from that for a reduced model ($\chi^2 = 2(LL_1 - LL_0)$). A good model is indicated by a low nonsignificant χ^2 test statistic ($P > .05$). Apart from the χ^2 test statistic, Akaike's Information Criterion ($AIC = \chi^2 - 2 \times \text{degrees of freedom}$) was computed. The lower the AIC, the better is the fit of the model to the observed data.

Reductions of the model were based on the expectations raised by previous studies. In detail, a simplex structure for genetic influences, a common factor for shared environmental influences and time-specific structure for unique environmental influences is expected. Estimates of genetic, shared environmental, and unique environmental influences on the age-specific variance and between age covariance of general cognitive abilities are reported based on the Cholesky decomposition model, the full simplex model, and the best fitting reduced model.

RESULTS

Descriptive statistics for FSIQ at 5, 7, 10, and 12 years of age showed that the variables were approximately normal distributed (Table I). Table II shows the twin correlations for the five zygosity groups calculated separately for each age. MZ correlations are higher than DZ correlations, suggesting genetic influences at each age. The low DOS correlation at age 12 suggests sex

Table I. Descriptive Statistics for Full-Scale IQ at Different Ages

	<i>N</i> ^a	Mean age	Min	Max	Mean	Std	Skewness		Kurtosis	
								S.E.		S.E.
FSIQ5	415	5.3	64	142	102.75	13.18	-.059	.120	.209	.239
FSIQ7	382	6.8	62	145	102.90	14.67	-.127	.125	.023	.249
FSIQ10	392	10.0	63	145	106.96	15.54	-.066	.123	-.166	.246
FSIQ12	381	12.0	61	138	100.03	13.18	-.039	.125	.177	.249

^a Number of children in the study.

differences and univariate model fitting procedures were used to explore this possibility. Estimates for genetic and shared environmental influences based on the univariate model-fitting procedure are presented in Table III. These results are consistent with previous results (Boomsma and Van Baal, 1998; Bouchard and McGue, 1981) showing increase of genetic influences and diminishing effects of shared environment over the years. Shared environmental influences are insignificant at ages 10 and 12. Univariate model fitting showed no presence of sex differences at the four ages separately and no presence of sex-specific genes at age 12.

To get a first impression of the developmental pattern of cognitive abilities, phenotypic cross correlations over time were calculated (Table IV). All correlations are rather large, which indicates a strong degree of stability of intellectual performance. This structure may best be described by a common factor mechanism. Cross correlations over time for monozygotic (MZ) and dizygotic (DZ) twins were calculated separately to explore the genetic and environmental influences on the observed stability. As can be seen in Table IV, the MZ cross correlations over time (above the diagonal) are higher than the DZ cross correlations over time (below the diagonal), suggesting that stability in intelligence over time is

mainly due to genetic factors. Further, when the correlations of the adjoining age-intervals are compared (ages 5–7; ages 7–10; ages 10–12), the increased difference between MZ and DZ correlations suggests an increase in the genetic contribution to stability with increasing age.

Analyses were continued with the application of the different models to the longitudinal data. Model-fitting procedures yielded the results presented in Table V. The genetic simplex model without restrictions (model 2) was taken as a reference for evaluating changes in χ^2 and associated degrees of freedom of more parsimonious models. First, reduction of the model was based on the expectation of age-specific unique environmental factors only (model 3). No significant change in χ^2 arose. Second, model reduction was based on the expectation of a common factor for shared environmental influences (model 4). Because the order of model reduction may influence the fit of the model, a model with a common factor for genetic influences and a simplex structure for shared environmental influences was fitted to the data as well (model 5). No clear distinction could be made between models 4 and 5, both being more parsimonious than model 3 but not significantly different. A model with a common factor for both genetic and shared environmental influences, allowing for time-spe-

Table II. Twin Correlations with 95% Confidence Intervals

Age	MZF ^a	DZF	MZM	DZM	DOS
5	.78 (.64–.87) 46 ^b	.73 (.53–.85) 37	.77 (.62–.87) 42	.53 (.29–.72) 43	.64 (.41–.79) 39
7	.77 (.61–.87) 41	.50 (.20–.70) 34	.56 (.29–.74) 37	.41 (.13–.63) 41	.56 (.30–.74) 38
10	.87 (.78–.92) 43	.45 (.16–.67) 37	.73 (.54–.85) 38	.53 (.28–.72) 41	.50 (.21–.70) 37
12	.86 (.76–.92) 43	.67 (.46–.82) 37	.84 (.71–.91) 36	.57 (.32–.75) 39	.35 (.03–.60) 35

^a MZF = monozygotic female; DZF = dizygotic female; MZM = monozygotic male; DZM = dizygotic males; DOS = dizygotic opposite sex.

^b Number of complete twin pairs.

Table III. Univariate Model-Fitting Results for the Four Ages

	Model	-2LL	df	$\Delta\chi^2$	Δdf	p	A	C	E
5	ACE + SD ^a	3178.20	408						
	ACE	3180.40	411	2.20	3	.53	.26 (.03-.52) ^b	.50 (.26-.68)	.24 (.18-.33)
	AE	3193.71	412	13.31	1	.00			
	CE	3185.25	412	4.85	1	.03			
7	ACE + SD ^a	3051.33	375						
	ACE	3054.37	378	3.04	3	.39	.39 (.07-.72)	.30 (.00-.55)	.31 (.23-.44)
	AE	3058.12	379	3.75	1	.05	.70 (.60-.78)	—	.30 (.22-.40)
	CE	3059.83	379	5.46	1	.02			
10	ACE + SD ^a	3135.48	385						
	ACE	3140.87	388	5.39	3	.15	.54 (.28-.83)	.25 (.00-.48)	.21 (.15-.29)
	AE	3143.62	389	2.75	1	.10	.80 (.72-.85)	—	.20 (.15-.28)
	CE	3156.99	389	16.12	1	.00			
12	ACE+ r _g ^{freec} + SD ^a	2903.40	373						
	ACE+ SD ^a	2903.71	374	.31	1	.58			
	ACE	2908.72	377	5.01	3	.17	.64 (.40-.88)	.21 (.00-.43)	.15 (.11-.22)
	AE	2910.81	378	2.09	1	.15	.85 (.79-.89)	—	.15 (.11-.21)
	CE	2936.28	378	27.56	1	.00			

^a Model with sex differences for parameter estimates.

^b 95% confidence intervals.

^c Model with sex-specific genes.

cific influences as well, did not give a significant worse fit (model 6). Further, it was tested whether dropping the age-specific influences, either genetic or shared environmental, altered the χ^2 significantly (model 7 and model 8). Based on the difference in χ^2 and the lower AIC, model 7 was preferred above model 8. The genetic (co)variance is modeled as a common factor without specifics, whereas the shared environmental (co)variance is modeled as a common factor with specifics. These results suggest that stability in cognitive performance is mainly due to genetic factors. Finally, a model with a common factor, without time-specific influences for both genetic and shared environmental influences showed a significant increase in χ^2 (model 9).

Estimates of the path coefficients for the best fitting model (model 7) are presented in Fig. 2. The percentage of age-specific variance explained by genetic, shared environmental and unique environmental factors based on the Cholesky decomposition (model 1), the full simplex model (model 2), and the best fitting model (model 7) are presented in Table VI. Table VII contains the percentages of between-age covariances explained by genetic, shared environmental, and unique environmental factors based on the Cholesky decomposition, the full simplex model, and the best fitting model. Indicated by the observed MZ and DZ cross correlations, genes become more important in explaining stability in cognitive performance with increasing age.

Table IV. Phenotypic Cross Correlations for FSIQ, Calculated for the Complete Dataset and MZ (Above Diagonal) and DZ (Below Diagonal) Cross Correlations over Time for FSIQ

Total sample	5	7	10	12
5	1.00	.65 (.59-.70)	.65 (.59-.70)	.64 (.57-.69)
7		1.00	.72 (.67-.77)	.69 (.63-.74)
10			1.00	.78 (.74-.82)
12				1.00
DZ/MZ	5b	7b	10b	12b
5a	—	.66 (.54-.75)	.67 (.56-.76)	.68 (.57-.77)
7a	.42 (.30-.54)	—	.71 (.60-.79)	.68 (.57-.77)
10a	.42 (.30-.54)	.39 (.26-.52)	—	.79 (.70-.85)
12a	.42 (.29-.54)	.42 (.29-.54)	.45 (.32-.57)	—

Table V. Model Fitting Results for FSIQ

Model	-2LL	df	χ^2	Δ df	Compared to model	<i>P</i>	AIC
1. A: Cholesky C: Cholesky E: Cholesky	11527.470	1520					
2. A: Full simplex structure C: Full simplex structure E: Full simplex structure with time-specific factors ^a	11510.105	1508					
3. A: Full simplex structure C: Full simplex structure E: Time-specific factors only ^b	11517.278	1512	5.681	4	2	.22	-2.319
4. A: Full simplex structure C: Common factor + specifics E: Time-specific factors only ^b	11513.722	1511	3.617	3	2	.31	-2.383
5. A: Common factor + specifics C: Full simplex structure E: Time-specific factors only ^b	11517.303	1511	7.198	3	2	.07	1.198
6. A: Common factor + specifics C: Common factor + specifics E: Time-specific factors only ^b	11513.743	1510	3.638	2	2	.16	-.362
7. A: Common factor C: Common factor + specifics E: Time-specific factors only ^b	11513.743	1514	—	4	6	1.00	-8.000
8. A: Common factor + specifics C: Common factor E: Time-specific factors only ^b	11521.677	1514	7.934	4	6	.09	-.066
9. A: Common factor C: Common factor E: Time-specific factors only ^b	11545.797	1518	32.05	8	6	.00	16.050

^a These time-specific factors are equal at all ages.

^b These time-specific factors are estimated separately at every age.

As opposed to this outcome, the shared environment accounts for a decreasing portion of the covariance between age intervals, whereas the unique environment explains, in general, around one quarter of the total variance at each age (Table VI). The unique environment contributes only minimally to the observed covariance between ages (Table VII). It should be noted that the genetic, shared environmental and unique environmental variance components estimated from fit-

ting the multivariate models to these data are somewhat different from what univariate analyses at each age separately might yield. These differences arise because the multivariate models take into account the cross-sibling cross-time covariance structure, which can affect the within-time parameter estimates. In addition, multivariate model-fitting increases the power to detect shared environmental influences as a source of familial aggregation.

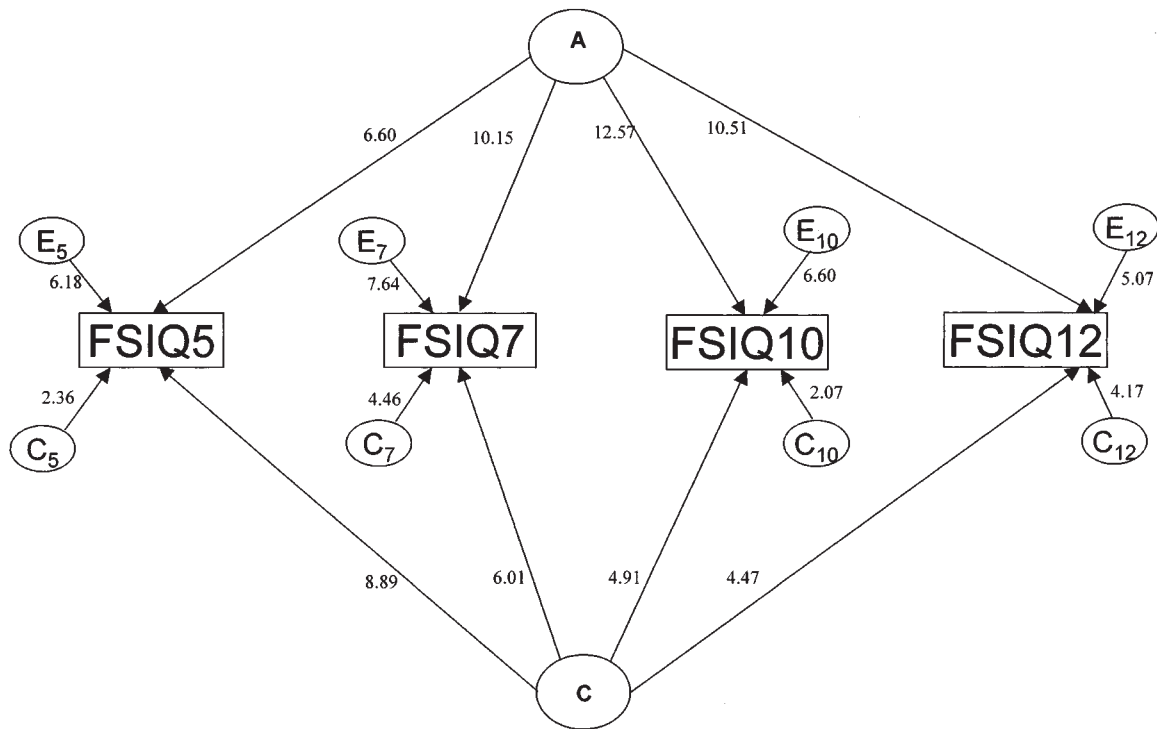

Fig. 2. Model 7; common factor for A, common factor with time-specific influences for C and time-specific influences for E.

DISCUSSION

The influences of genes and environment on cognitive development and on its developmental structure

were studied in a longitudinal sample of Dutch twins at 5, 7, 10, and 12 years of age. It can be concluded that the development of general cognitive abilities is a continuous process. Continuity is represented by a com-

Table VI. Percentage of Variance Explained by A, C, and E, Based on a Cholesky Decomposition, a Simplex Model, and the Best Fitting Model, with 95% Confidence Intervals

Model 1	Variance	A Cholesky	C Cholesky	E Cholesky		
	5	.30 (.15-.54)	.46 (.24-.62)	.24 (.18-.30)		
	7	.42 (.21-.67)	.28 (.05-.49)	.30 (.22-.39)		
	10	.61 (.36-.82)	.19 (.00-.43)	.20 (.15-.27)		
	12	.62 (.39-.86)	.23 (.00-.45)	.15 (.11-.21)		
Model 2	Variance	A simplex	C simplex	E simplex		
	5	.38 (.22-.60)	.39 (.18-.56)	.23 (.18-.30)		
	7	.38 (.20-.63)	.32 (.09-.50)	.30 (.23-.39)		
	10	.72 (.33-.83)	.08 (.00-.46)	.20 (.15-.27)		
	12	.62 (.37-.85)	.23 (.01-.46)	.15 (.11-.21)		
Model 7	Variance	A common factor	C total	Common	Specific	E time specific
	5	.26 (.14-.46)	.51 (.31-.65)	.47	.04	.23 (.18-.29)
	7	.47 (.29-.62)	.26 (.11-.45)	.17	.09	.27 (.21-.35)
	10	.69 (.49-.82)	.12 (.00-.33)	.10	.02	.19 (.14-.25)
	12	.64 (.45-.77)	.21 (.09-.40)	.11	.10	.15 (.11-.20)

Table VII. Percentage of Covariance Explained by A, C, and E, Based on a Cholesky, Model, a Simplex Model, and a Restricited Model, with their 95% Confidence Intervals

Model 1	Covariance	A Cholesky	C Cholesky	E Cholesky
	5-7	.55 (.32-.87)	.40 (.10-.63)	0.5 (.00-.12)
	5-10	.66 (.40-.99)	.34 (.01-.58)	.00 (.00-.07)
	5-12	.66 (.42-.98)	.34 (.02-.58)	.00 (.00-.04)
	7-10	.71 (.43-.93)	.21 (.00-.48)	.08 (.02-.15)
	7-12	.73 (.46-.98)	.24 (.01-.50)	.03 (.00-.10)
	10-12	.78 (.51-.99)	.20 (.00-.45)	.02 (.00-.08)
Model 2	Covariance	A simplex	C simplex	E simplex
	5-7	.59 (.33-.95)	.38 (.04-.63)	.03 (.00-.10)
	5-10	.82 (.55-.99)	.17 (.00-.45)	.01 (.00-.04)
	5-12	.76 (.48-.99)	.24 (.01-.52)	.00 (.00-.02)
	7-10	.73 (.46-.97)	.20 (.00-.46)	.07 (.01-.15)
	7-12	.69 (.42-.98)	.29 (.01-.56)	.02 (.00-.07)
	10-12	.84 (.55-.99)	.13 (.00-.42)	.03 (.00-.08)
Model 7	Covariance	A common factor	C common factor	E time specific ^a
	5-7	.56 (.35-.83)	.44 (.17-.65)	—
	5-10	.66 (.42-.95)	.34 (.05-.58)	—
	5-12	.64 (.41-.92)	.36 (.08-.59)	—
	7-10	.81 (.55-.98)	.19 (.02-.45)	—
	7-12	.80 (.54-.98)	.20 (.02-.46)	—
	10-12	.86 (.63-.99)	.14 (.01-.37)	—

^a E is represented in time-specific influences only.

mon factor, with age-specific factor loadings, for both genetic and shared environmental influences. Change in development, represented by age-specific factors, are presented in the shared environmental structure and, as expected, in the unique environmental structure. Further, decomposition of the between-age covariances in additive genetic, shared environmental, and unique environmental influences showed that the continuity in cognitive abilities is mainly due to additive genetic factors.

In this study, increasing additive genetic influences and decreasing influences of shared environmental factors are found in both age-specific variances and between-age covariances. The increase of genetic influences on cognitive functioning throughout development is already well established in U.S. samples and is now also found in a sample of Dutch twins. In the common factor pattern for genetic influences (model 7; see Fig. 2), increasing influences of heritability are represented by increasing factor loadings from age 5 to 10. Further, in the common factor pattern for shared environmental influences, decreasing influences are represented by decreasing factor loadings from age 5 to 10 and decreasing age-specific influences from age 5 to 10.

The developmental pattern for genetic influences found in this study is partly different from previous, com-

parable studies like the combined study of CAP, MLTS, and TIP (Cardon *et al.*, 1992; Fulker, *et al.*, 1993). Results provided by these studies show a simplex pattern for genetic influences with genetic innovation at 2, 3, and 7 years of age, with the suggestion that genetic innovation at age 7 may be due to “the novel environmental challenge of schooling”. In our study, no indication for genetic innovation is obtained. Comparison of the different longitudinal studies is limited due to distinct ages of testing. In our study, no information is available for cognitive development prior to age 5 and the results, mainly presented by the CAP studies, provide no information on the development of general cognitive ability between ages 9 and 16. Another difficulty in longitudinal studies in general and in comparing different longitudinal studies on cognitive development in particular is the measurement of cognitive performance. There are no cognitive assessments that are common to all ages, so different age-appropriate instruments must be used. One of the difficulties with this is that no distinction can be made between true changes in development and changes related to different measurement instruments. A major advantage of our longitudinal study is that the same intelligence test (RAKIT), with age-specific items, is used at the first three measurement occasions. Further,

the intelligence test used at the fourth measurement occasion (WISC-R) shows a high concurrent validity with the RAKIT (.86 for FSIQ) (Pijl *et al.*, 1984).

More striking is the finding for shared environmental influences. Previous studies suggested a common factor for shared environmental influences. Our study indicates that, besides a continuing influence of shared environmental factors, age-specific influences are present. These age-specific effects were significant, but the proportion of variance explained is much smaller compared to the proportion explained by the shared environmental factor common to all ages. This common factor could be accounted for by SES and parental education, because these environmental aspects are not sensitive to large changes over a time span of 7 years. Aspects outside the family environment, such as friends or being a member of a sportsclub, might also cause similarities between two children of a twin pair during childhood. For the age-specific shared environmental influences one may consider the school environment. Information on same or different teacher for both children of a large sample of 12-year-old twin pairs ($N = 1,164$) indicates that in 63% of the cases both children of a twin pair are taught by the same teacher, whereas 37% go to separate classes. This ratio makes teacher or classroom environment a shared environmental influence for the majority of the children. In the Dutch school system, children move to a different teacher each school year; this results in a lack of continuity in this particular aspect of shared environment. So, these shared but age-specific experiences within the classroom may be represented by the age-specific factors as specified significant in the best fitting model. In addition to SES and aspects of school, the direct neighborhood experienced during childhood may contain shared environmental influences. Nearly half of the initial sample (47%) changed residency after the twins were born. The majority of those families who moved once during the twins' lifetime did so before the twins' fifth birthday. If this particular source of shared environmental variance has an impact on the development of cognition, it may be considered a continuous source of influence. That is, the impact of change of residency remains detected years after the actual change took place. Further, the model fitting results imply that this hypothetical influence of the shared environment diminishes with increasing age. This is what one expects when a change of domicile has taken place early in a child's life. The unique environment was found to explain a substantial portion of the variance at each age (best model, range from 15%–27%). With

respect to developmental aspects of the data, the unique environment acts in a well-established manner. The environment that is uniquely experienced by an individual contributes to change rather than stability in cognitive performance.

The above mentioned findings are in line with those obtained by multivariate analyses of the RAKIT subtests collected at the twin's ages 5, 7, and 10 (Rietveld *et al.*, submitted). Subtest performance, either verbal or nonverbal, displays stability mainly due to genetic effects and to a lesser extent to shared environmental effects. The unique environment is important at each age but plays no role of significance when one attempts to explain stability in subtest performance.

For future purposes of disentangling genetic and environmental influences on cognitive development, it might be important to collect more information on possible shared or unique environmental influences, because previous studies on the development of cognition mainly focus on heritability estimates. The nature of the influences of shared and unique environment is underexposed and only modestly discussed in behavior genetic literature. Ideally, one should measure a range of potential environmental influences to be able to gain more insight into the exact nature of these influences.

Besides the above mentioned use of different age-appropriate tests, longitudinal studies in general are subjected to other unavoidable difficulties. A major difficulty in longitudinal studies is the participation rate. By studying the same subjects over the years, dropout is inevitable. In our study the dropout rate is low. Over 90% of the initial sample continued to participate at the fourth measurement occasion, and the reasons for leaving the study were found unrelated to the initial measurement of the twins' FSIQ. Complete intelligence data at all ages are available for 84% of the sample.

Our ongoing longitudinal study has the potential to overcome some of the mentioned shortcomings of the unknown influence of the use of different intelligence tests. To clarify the influences on the change of FSIQ test between ages 10 and 12, a sample of younger siblings of the twins will be tested by making use of both tests. A continuity of the study has just begun to see whether hormonal influences, induced by puberty, change the developmental pattern of general and specific cognitive abilities between ages 12 and 14.

In summary, the results of our study did not fully reach our prior expectations based on previous studies. In our study, genetic influences are the main driving force behind continuity in general cognitive ability. The shared environment contributes to continuity and to a

lesser extent to change. As expected, unique environmental influences contribute to the change of cognitive abilities solely.

APPENDIX I

The longitudinal simplex model consists of a measurement model, which represents the relation between the latent and the observed variables ($FSIQ = F + U$), in which $FSIQ$ is the observed variable, F is the latent variable (A , C , or E), and U is the measurement error. Further, it consists of a structural equation model, which represents the relation among the latent variables ($A = \beta A + \xi$), in which A is the latent variable, β is the transmission factor, and ξ is the innovation factor. A simplex model is a first-order autoregressive process. In other words, each latent variable is influenced by the preceding latent variable (see Fig. 1):

$$A_i = \beta_i A_{i-1} + \xi_i$$

In which β_i is the autoregressive (transmission) coefficient and ξ_i represents innovation at that point in time. Further, units of measurement in the latent variables are the same as in the observed variables resulting in:

$$FSIQ = (I - \beta)^{-1} \xi + U$$

Hence, the expected additive genetic covariance matrix is:

$$H = (I - G)^{-1} A^* A'^* ((I - G)^{-1})'$$

where genetic transmission parameters are modeled in matrix G , a 4×4 matrix with three transmission parameters on its subdiagonal, based on the four points in time used in this study. These autoregressive coefficients ($\beta_G(t)$) are a measure of the amount of genetic variation at time point $t - 1$ that is transmitted to time point t and therefore associated with stability. Genetic innovation parameters are modeled in matrix A , a 4×4 diagonal matrix. These innovation parameters ($\xi_G(t)$) denote the effects of new genes turned on at time point t and will therefore lower the stability of the genetic process between $t - 1$ and t . Similar parameter matrices can be defined for unique and common environment.

ACKNOWLEDGMENT

This research was financially supported by The Netherlands Organization for Scientific Research (575-25-012).

REFERENCES

- Alarcón, M., Plomin, R., Fulker, D. W., Corley, R., and DeFries, J. C. (1998). Multivariate path analysis of specific cognitive abilities data at 12 years of age in the Colorado Adoption Project. *Behav. Genet.* **28**:255–264.
- Alarcón, M., Plomin, R., Fulker, D. W., Corley, R., and DeFries, J. C. (1999). Molarity not modularity: Multivariate genetic analysis of specific cognitive abilities in parents and their 16-year-old children in the Colorado Adoption Project. *Cog. Dev.* **14**:175–193.
- Benson, J. B., Cherny, S. S., Haith, M. M., and Fulker, D. W. (1993). Rapid assessment of infant predictors of adult IQ: Midtwin-midparent analyses. *Dev. Psychol.* **29**:434–447.
- Bleichrodt, N., Drenth, P. J. D., Zaal, J. N., and Resing, W. C. M. (1984). *Revisie Amsterdamse Kinder Intelligentie Test* [Revised Amsterdam Child Intelligence Test]. Swets and Zeitlinger B. V., Lisse, The Netherlands.
- Boomsma, D. I., Orlebeke, J. F., and Van Baal, G. C. M. (1992). The Dutch Twin Register: Growth data on weight and height. *Behav. Genet.* **22**:247–251.
- Boomsma, D. I., and Molenaar, P. C. (1987). The genetic analysis of repeated measures. I. Simplex models. *Behav. Genet.* **17**(2):111–123.
- Boomsma, D. I. (1993). Current status and future prospects in twin studies of the development of cognitive abilities: Infancy to old age. In Bouchard, T. J. Jr, Propping, P. (Ed.), *Twins as a Tool of Behavioral Genetics*. John Wiley & Sons Ltd., pp. 67–82.
- Boomsma, D. I., and Van Baal, G. C. M. (1998). Genetic influences on childhood IQ in 5- and 7-year-old Dutch twins. *Dev. Neuropsychol.* **14**:115–126.
- Bouchard, T. J., Jr. (1981). Galton Lecture: Behaviour genetic studies of intelligence, yesterday and today: The long journey from plausibility to proof. *J. Biosoc. Sci.* **28**:527–555.
- Bouchard, T. J. Jr., and McGue, M. (1981). Familial studies of intelligence: a review. *Science* **212**:1055–1059.
- Bratko, D. (1996). Twin study of verbal and spatial abilities. *Personal and Individual Differences* **21**:621–624.
- Cardon, L. R., and Fulker, D. W. (1994). A model of developmental change in hierarchical phenotypes with application to specific cognitive abilities. *Behav. Genet* **24**:1–16.
- Cardon, L. R., Fulker, D. W., DeFries, J. C. and Plomin, R. (1992). Continuity and change in general cognitive ability From 1 to 7 years of age. *Dev. Psychol.* **28**:1–10.
- Cherny, S. S., and Cardon, L. R. (1994). General cognitive ability. In DeFries, J. C., Plomin, R. and Fulker, D. W. (eds.), *Nature and Nurture During Middle Childhood*. Blackwell, Oxford, England, Ch. 4.
- DeFries, J. C., Plomin, R., and LaBuda, M. C. (1987). Genetic stability of cognitive development from childhood to adulthood. *Dev. Psychol.* **23**:4–12.
- DiLalla, L. F., Thompson, L. A., Plomin, R., Phillips, K., Fagan III, J. F., and Haith, M. M. (1990). Infant predictors of preschool and adult IQ: A study of infant twins and their parents. *Dev. Psychol.* **26**:759–769.
- Eaves, L. J., Long, J., and Heath, A. C. (1986). A theory of developmental change in quantitative phenotypes applied to cognitive development. *Behav. Genet.* **16**:143–162.
- Fulker, D. W., Cherny, S. S., and Cardon, L. R. (1993). Continuity and change in cognitive development. In Plomin, R., and McClearn, G. E. (eds.), *Nature, Nurture and Psychology*. American Psychological Association, Washington, D.C., pp. 77–97.
- Fulker, D. W., DeFries, J. C., and Plomin, R. (1988). Genetic influence on general mental ability increases between infancy and middle childhood. *Nature* **336**:767–769.
- Guttman, L. (1954). A new approach to factor analysis: The radax. In Lazarsfeld, P. F. (ed.), *Mathematical Thinking in the Social Sciences*. Free Press, Glencoe, IL, pp. 258–349.

- Humphreys, L. G., and Davey, T. C. (1988). Continuity in intellectual growth from 12 months to 9 years. *Intelligence* **12**:183–197.
- LaBuda, M. C., DeFries, J. C., Plomin, R., and Fulker, D. W. (1986). Longitudinal stability of cognitive ability from infancy to early childhood: Genetic and environmental etiologies. *Child Dev.* **57**:1142–1150.
- Loehlin, J. C., Horn, J. M., and Willerman, L. (1989). Modeling IQ change: Evidence from the Texas Adoption Project. *Child Dev.* **60**:993–1004.
- McCartney, K., Harris, M. J., and Bernieri, F. (1990). Growing up and growing apart: A developmental meta-analysis of twin studies. *Psychol. Bull.* **107**:226–237.
- McGue, M., Bouchard, T. J., Iacono, W. G., and Lykken, D. T. (1993). Behavioral genetics of cognitive ability: A life-span perspective. In Plomin, R., and McClearn, G. E. (eds.), *Nature, nurture and psychology*. American Psychology Association, Washington, D.C., pp. 59–76.
- Neale, M. C., Boker, S. M., Xie, G., and Maes, H. H. (1999). *Mx: Statistical Modeling*, 5th ed. Box 126 MCV, Richmond, VA 23298: Department of Psychiatry.
- Patrick, C. L. (2000). Genetic and environmental influences on the development of cognitive abilities: Evidence from the field of developmental behavior genetics. *J. School Psychol.* **38**:79–108.
- Phillips, K., and Fulker, D. W. (1989). Quantitative genetic analysis of longitudinal trends in adoption designs with application to IQ in the Colorado Adoption Project. *Behav. Genet.* **19**:621–658.
- Pijl, Y. J., Hofman, R. H., Bleichrodt, N., Resing, W. C. M., Lutje-Spelberg, H., Bruijn, E., de, and Zaal, J. N. (1984). *Vergelijkbaarheid van de WISC-R en RAKIT*. Research Instituut voor Onderwijs in het Noorden, Vrije Universiteit., Amsterdam.
- Plomin, R., Campos, J., Corley, R., Emde, R. N., Fulker, D. W., Kagan, J., Reznick, J. S., Robinson, J., Zahn-Waxler, C., and DeFries, J. C. (1990). Individual differences during the second year of life: The MacArthur Longitudinal Twin Study. In Colombo, J., and Fagan, J. (eds.), *Individual Differences in Infancy: Reliability, Stability, and Predictability*. Hillsdale, New York.
- Plomin, R., and DeFries, J. C. (1983). The Colorado Adoption Project. *Child Dev.* **54**:276–289.
- Plomin, R., and DeFries, J. C. (1985). Origins of individual differences in infancy. In Plomin, R., and DeFries, J. C. (eds.), *Origins of Individual Differences in Infancy*, Orlando, pp. 48–64, 90–127.
- Plomin, R., Emde, R. N., Braungart, J. M., Campos, J., Corley, R., Fulker, D. W., Kagan, J., Reznick, J. S., Robinson, J., and Zahn-Waxler, C. (1993). Genetic change and continuity from fourteen to twenty months: The MacArthur Longitudinal Twin Study. *Child Dev.* **64**:1354–1376.
- Plomin, R., Fulker, D. W., Corley, R., and DeFries, J. C. (1997). Nature, nurture, and cognitive development from 1 to 16 years: A parent-offspring adoption study. *Psychol. Sci.* **8**:442–447.
- Posthuma, D., De Geus, E. J., Bleichrodt, N., and Boomsma, D. I. (2000). Twin-singleton differences in intelligence?, *Twin Res.* **3**(2):83–87.
- Rietveld, M. J. H., Van Baal, G. C. M., Dolan, C. V., and Boomsma, D. I. (2000). Genetic factor analyses of specific cognitive abilities in 5-year-old Dutch children. *Behav. Genet.* **30**(1):29–40.
- Rietveld, M. J. H., Dolan, C. V., Van Baal, G. C. M., and Boomsma, D. I. (submitted). A twin study of differentiation of cognitive abilities in childhood.
- Rijsdijk, F. V., and Boomsma, D. I. (1997). Genetic mediation of the correlation between peripheral nerve conduction velocity and IQ. *Behav. Genet.* **27**(2):87–98.
- Rijsdijk, F. V., Vernon, P. A., and Boomsma, D. I. (1998). The genetic basis of the relation between speed-of-information-processing and IQ. *Behav. Brain Res.* **95**(1):77–84.
- Skodak, M., and Skeels, H. M. (1949). A final follow-up of one hundred adopted children. *J. Genet. Psychol.* **75**:85–125.
- Thompson, L. A. (1993). Genetic contributions to intellectual development in infancy and childhood. In Vernon, P. A. (ed.), *Biological Approaches to the Study of Human Intelligence*, pp. 95–138.
- Van Haasen, P. P., De Bruyn, E. E. J., Pijl, Y. J., Poortinga, Y. H., Lutje-Spelberg, H. C., Vander Steene, G., Coetsier, P., Spoelders-Claes, R., and Stinissen, J. (1986). *Wechsler Intelligence Scale for Children-Revised, Dutch Version*. Swets & Zetlinger B. V., Lisse, The Netherlands.
- Wilson, R. S. (1993). The Louisville Twin Study: Developmental synchronies in behavior. *Child Dev.* **54**:298–316.