

## Genetic Defects in Karnataka (India): Evidence and Factors

V. Rami Reddy and B.K. Chandrasekhar Reddy

*Department of Anthropology, S.V. University, Tirupati 517 502, Andhra Pradesh, India*

**KEY WORDS** Pedigree; genetic defects; variable expression; Karnataka

**ABSTRACT** Five family pedigrees of people of Karnataka have been analysed to study the inheritance pattern of the genetic defects of missing left forearm, polydactyly, atrophied toes and nails and lobster claw deformity of hands and syndactylous feet, all possibly autosomal dominant genetic traits. These deformities affected eight persons among a total of 211 individuals represented by five pedigrees belonging to 18 generations. They are from Lingayat, Muslim, Valmiki and Brahmin communities inhabiting Dharwad city, Hosahalli Village in Dharwad district and Hubli city. The first pedigree siblings of the propositus with missing left forearm and the second and third pedigree siblings as well as the ancestors of the propositi with polydactylous hands were all phenotypically normal, indicating the variable expression of the gene for polydactyly. The fourth pedigree propositus with atrophied toes and nails might be attributed to a condition known as anonychia. The fifth pedigree proposita with cleft hands and syndactylous feet might have resulted due to autosomal dominant genes with variable expressivity and penetrance. The variable expression of genes for polydactyly and anonychia in the Karnataka females is predominantly a vertical type of inheritance rather than horizontal one. With the help of these pedigrees an attempt has been made to interpret the pattern of inheritance of the reported anomalies.

### INTRODUCTION

There are two important concepts in the study of genetics that stand out prominently: one is the constancy and regularity of a given genotype in its expression from parents to offspring as also in its effect on development and the other is the variability in the expression of genes. Both these characters infuse dynamism to the subject of genetics in general and human genetics in particular and make the very pattern of inheritance interesting in its general understanding and the implications of its interpretation. In the case of variability in the expression of genes, it has to be remembered, as Curt Stern (1960) rightly put it, that there are "numerous interconnecting steps" between gene and effect, the variability of which may cause change in the expression of the gene. The other possibility, namely the variability of the gene itself or mutation as the cause of the variable expression of a gene can not also be ruled out, but it has been well established by the study of transmission of genes through germ cells from parents to offspring that such a possibility is rare. We have to therefore fall back to the consideration of the concept of interacting developmental processes in the interpretation of the variable expression of genes.

The variable expression of genes resulting in different defects may involve single genes,

multiple genes and chromosomes. The single gene defects which occur in simple Mendelian fashion are generally uncommon, while those of multiple genes together with the environmental factors and chromosomes are common. The rapid strides made by genetics in the west greatly owe to the explosion of knowledge on the genetic defects whereas in India the expertise, resources and energies have all along been directed to tackling the diseases mainly caused by malnutrition, infections etc. rather than in the investigation of genetic disorders, their analysis and estimation of their risk to health as also their curation or therapy and appropriate counselling. Bhatnagar et al. (1986) discussed at length about the scope and relevance of genetic counselling and the circumstances under which it is rendered.

As genetic disorders affect tissues of different systems of the human beings, they cut across various medical fields and non-medical disciplines like molecular biology and human biology, it is needless to say as Jagannatha Reddy (1978) opined that the screening of genetic disorders is an interdisciplinary pursuit. Narahari (2003) in his recent study also emphasized the need for linkage analysis at protein level for understanding the mechanism of inheritance of autosomal dominant traits.

India with thousands of endogamous caste/tribal population groups apart from the religious groups like Muslims and Christians practicing

different mating patterns and inhabiting a wide range of environmental situations offers excellent opportunities to screen the genetic abnormalities. A number of earlier studies, both prospective and retrospective, have been based mostly on hospital data in different parts of the country. In majority of the cases, there was no proper diagnosis of the abnormalities nor the studies have been planned with appropriate design and methodology, let alone their management (Verma 1978). There is also no concern shown by any quarter in the government or outside to undertake the important task of surveying the different ethnic groups of the country for understanding the distribution pattern of various abnormalities and their scientific interpretation as also publication.

#### PRESENT STUDY

The present paper is attempted from a part of the data generated through a larger project undertaken by the first author. The data on a family pedigree of the multiple abnormalities of polydactyly, clinodactyly and hare-lip from the same project was earlier published (Rami Reddy et al. 1986). In this paper the data based on the screening of five pedigrees among the people of North Karnataka affected by the genetic anomalies of missing left forearm, polydactyly, atrophied toes and nails and lobster clawed hands and syndactylous feet is endeavoured to be presented.

#### MATERIALS AND METHODS

Hubli and Dharwad cities, and Hosahalli village in Savanur taluk, located 60 and 77 kms. to the southeast of former cities are the places from where the study samples of the five pedigrees, containing a total of 211 individuals representing 18 generations, have been drawn. There are eight affected persons. The members of the first and third pedigrees belong to the Lingayat community, those of the second pedigree to the Muslim community, those of the fourth pedigree to the Valmiki community and those of the last pedigree to the Brahmin community. The Socio-cultural traditions as also lifestyles and religious practices of these communities broadly conform to those of their counterparts in other parts of South India. Further these communities like the latter elsewhere in the country practise consanguinity in varying

degrees which generally occurs in higher proportions.

The first pedigree from Dharwad City consists of a total of 15 individuals spread over three generations. The affected person with missing left forearm was a male aged about 22 years belonging to the III generation. There were 29 persons in four generations observed in the second pedigree with two males from Hosahalli village - father aged about 30 years and son aged about eight years - affected by polydactyly in the III and IV generations respectively. The third pedigree from Hublicity, also of polydactyly, contained 33 individuals traced through three generations. The affected persons were girls aged about 17 years and one-and-a-half months respectively. The fourth pedigree, an uncommon one of a woman aged about 40 years, was affected by atrophy of toes and nails and came from the II generation of a family pedigree of 25 individuals spread over three generations. The last pedigree which is the largest and rarest of all the pedigrees, was also recorded from the Hubli city. It consisted of a total of 109 individuals distributed in five generations. The girl affected by the lobster clawed deformity of hands and syndactylous feet was about 19 years of age and belongs to the IV generation of the family. The other case was of a boy aged about six years from the V generation of the same pedigree in which only lobster-clawed hands were reported to have been observed.

During the course of investigation of each of the pedigrees, care was taken to verify the personal information of all the members, including the propositus/ proposita. They were carefully observed as well as interviewed for the different anomalies. Further, the information about the dead persons including their afflictions if any, was ensured to be accurate. This aspect of the data was recorded by interviewing the living family members and their neighbours as also their relatives in order to know whether the dead were affected by any congenital anomalies. Finally, the respective family pedigrees were prepared according to standard procedures, and photographs of the respective defects of the propositus/proposita were taken.

#### RESULTS AND DISCUSSION

The analysis of the data was undertaken with the help of field observations made on the

anomalies as well as with the information recorded and verified by interviewing the people themselves, with the photographs of the defects taken, with the pedigree charts prepared, with the records on the pedigrees and comparison of all these aspects with the available published literature on the subject. This was followed by the interpretation of the pattern of inheritance of the reported abnormalities. The pedigree charts and photographs of the defects of the respective propositus/proposita are shown in figures 1-12. Each of the pedigrees is separately dealt with as under.

**Missing Left Forearm**

This is perhaps the first case reported from India. The pattern of its inheritance is shown in figure 1 and the photograph of the propositus with the missing left forearm is shown in figure 6. The pedigree contains three generations of 15 individuals. The propositus aged about 22 years belonged to the III generation of the pedigree. Although the parents of the propositus are phenotypically normal, the occurrence of this congenital abnormality in the affected individual suggests that either parent must be heterozygous for the trait, or due to the incomplete expression of the gene for the trait. Information was also obtained regarding the persons died in the second and third generations of the pedigree, to have a complete understanding about the presence of the trait in all the sibships of the family in this generation.

Since the published literature either on the incidence or on the pattern of inheritance of this trait is extremely meagre, systematic pedigree

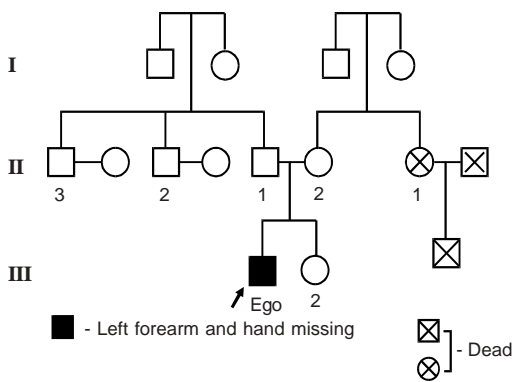

**Fig. 1. Pedigree missing left forearm and hand**

analysis could not be carried out in the light of the present one alone.

**Polydactylous Hands**

The family pedigrees of the individuals affected with polydactyly are shown in figures 2 and 3, duly supported by photographs of the respective anomaly as in figures 7-9. The propositus (Fig. 2) belongs to the IV generation of the family. He is an affected male aged about eight years. His father aged about 30 years was also affected with the anomaly while the mother was phenotypically normal. Since the gene for polydactyly is fully expressed phenotypically, the affected individual is homozygous for the trait. His father's genotype was also of the same type as expected since he is also phenotypically polydactylous. The maternal parent of the propositus might however be heterozygous with variable expressivity since she is phenotypically normal. The absence of expression of this gene either among the sibships of the III or IV generations might be due to variable expressivity of this gene (Malhotra 1964), or its incomplete penetrance or its absence among the persons in the pedigree. The condition of polydactyly in the affected individual is postaxial in nature represented by the left thumb divided with an extra finger bent on the ulnar direction.

Figure 3 shows the family pedigree of the two

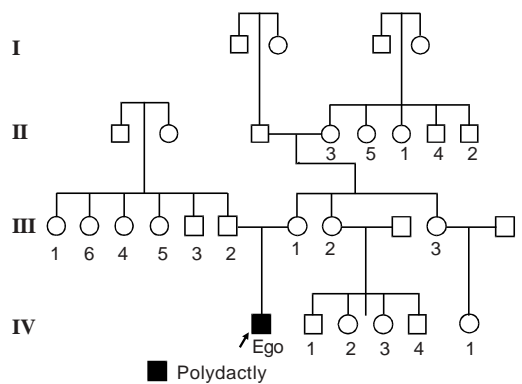

**Fig. 2. Pedigree showing polydactyly**

affected females by polydactyly both in the III generation. The affected are illustrated in figures 8-9. The parents of the affected individuals are phenotypically normal. The presence of this trait in the propositi might be due to the passage of the gene responsible for this trait either from the

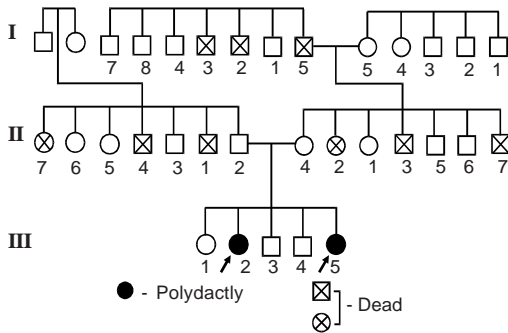

Fig. 3. Pedigree of Showing polydactyly

maternal or paternal parent, or from both. The normal phenotypic expression among the parents of the propositi reveals that either parent or both might be heterozygous with variable expressivity of the defective gene. The possibility of the existence of the gene responsible for this trait in the generation earlier than the observed I (first) generation of this pedigree can not be ruled out due to its skipping nature in some pedigrees reported earlier. The ratio between the affected and normal individuals in the III generation is 2:3, which supports the Mendelian mode of inheritance. The propositi of the pedigree has the right and left thumbs respectively divided with the extra fingers bent on the ulnar direction as in the previous pedigree.

#### Atrophied Fingers and Nails

This is a rare condition observed for the first time in a family pedigree in this part of South India and is shown in figures 4 and 10. The condition, identified as the atrophy of toes and nails, is believed to have resulted due to what is called anonychia (Roberts 1974). The proposita aged about 40 years at the time of investigation was found in the II generation of a family pedigree of three generations. The parents and sibs of the proposita were phenotypically normal. None of her children of either sex were affected with this abnormality. The reasons for the absence or its expression among the siblings of the III generation are beyond our comprehension in view of its absence among all the sibships of either sex of the III generation.

A cursory look at the published literature shows the non-availability of previous reports either on the incidence or on the mode of inheritance of this abnormality and therefore it is

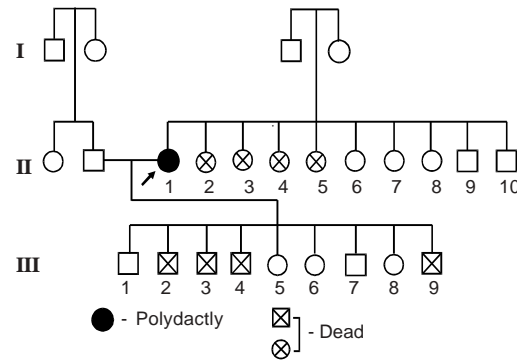

Fig. 4. Pedigree of Showing Atrophied (Reduced) Toes

rather difficult to interpret the nature of its exact mode of inheritance in the affected family merely based on the present pedigree.

#### Lobster Clawed Hands and Syndactylous Feet

In this pedigree, there are 109 individuals traced through five generations (Figs. 5, and 11-12). The proposita aged about 19 years was born to phenotypically normal parents, who were reported to be consanguineously related for over a number of generations. During the investigation, it was revealed that the girl underwent operation in 1957, just about a year after she was born for possible correction of the deformity in the hands. Before the operation, the first two digits of the right hand were separate while the third and fourth digits were fused and had nails. The left hand digits too were fused with three nails present on the fingerballs. By operative treatment, only thumb could be separated in either hand with the rest of the digits remained fused. The right hand presents bifid appearance with thumb separated from the other four fingers which are fused. The left hand has crooked thumb and the rest of the finger remnants are fused with local gigantism of ring finger (Fig. 11).

No corrective treatment was attempted on the syndactylous feet. Webbing on the right foot is present between the second and the third, and between the fourth and fifth toes. The first toe of this foot, which is somewhat curved outwardly, is free and in line with other toes. The fused right fourth and fifth toes, showing combined shortening, are approximately of the same length, the latter being prominently projected laterally. Webbing on the left foot is present between the

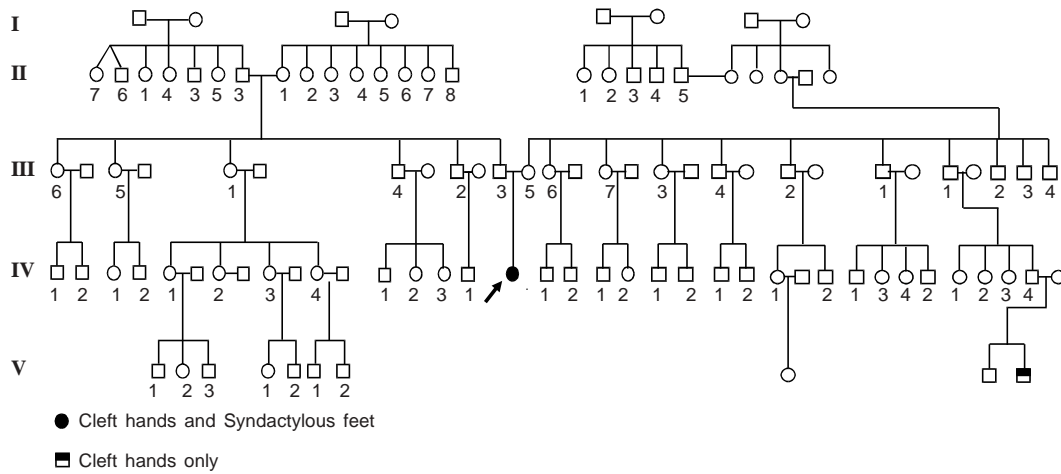

Fig. 5. Pedigree of Lobster-claw deformity of hands and Syndactylous feet



Fig. 6. Missing left forearm



Fig. 7. Polydactylous left hand

second, third and fourth toes, and the outcurved first and fifth toes are free. All the toes are of normal size. The syndactylous condition between the toes, extending nearly to their tips, manifests bilateral symmetry. It seems to have formed by the union of skin and fibrous tissue (Fig. 12). A rudimentary cleft exists between the right third and fourth toes, and between the left

first and second toes, and fourth and fifth toes. The proposita belongs to the IV generation of the family pedigree and the abnormality was an autosomally inherited dominant genetic trait. Both the parents of the affected person are phenotypically normal. A similar defect of clawed hands was reported to have occurred in a boy of six years belonging of the V generation of the



pedigree. He is the great grandson of the proposita's grandmother's elder sister. The occurrence of this abnormality in two persons among a total of 109 individuals of the family observed indicates its uncommonness substantiating the earlier findings.

The science of genetics has successfully disproved a large number of age-old misconceptions, false beliefs, impressions, myths, superstitions, etc. regarding the methods of inheritance of traits. These range from influence of blood, parents' age, drugs, acquired characteristics to heredity or environment and maternal impressions. In the case of a child born with only one hand, for instance, as Winchester (1969) states, the mother attributes the abnormality to a serious automobile accident witnessed by her in her late pregnancy. Such impressions can never occur and are scientifically untenable as revealed by the knowledge of genetics and embryology. One such case of an adult male with missing left forearm from the III generation of the Dharwad family pedigree of the present study (Figs. 1 & 6) is closely comparable to the one reported by Winchester (1969, Fig. 1-4). Owing to the limitations of this being the solitary case in the third generation, the absence of the affected persons in the first two generations, the numerically small size of the pedigree and lack of published literature, both on the incidence as well as on the pattern of inheritance of the abnormality, no convincing explanation can be advanced on its possible mode of inheritance. However, it may be surmised that the parents of the propositus were heterozygous for the defect or it might have occurred due to incomplete expression of the gene

Polydactyly, a genetic trait characterized by the presence of extra fingers or toes, is the first reported inherited trait in humans and is governed by a single gene effecting inheritance in an autosomal dominant fashion with variable expressivity and penetrance (Winchester 1969). This abnormality was also observed earlier in monkeys, horses, dogs, cats and other animals. Approximately one-half of the children of both sexes are affected from an affected couple. In some pedigrees, polydactyly occasionally skips a generation. Postaxial polydactyly is represented by a fully developed extra ulnar or fibular digit while preaxial polydactyly is expressed as an extra thumb or great toe (Woolf and Woolf 1970). In the case of the propositus from Hosahalli under

study (Figs. 2 & 7) the gene for polydactyly is fully expressed and hence it is homozygous for the trait as is his father who was also phenotypically polydactylous. The absence of the phenotypic expression of this abnormality either in the grand parental generation or in the siblings indicates the heterozygosity of the gene with variable expressivity or its incomplete penetrance, or even its absence. More or less similar explanation can be offered for the mode of inheritance of the polydactylous condition in the propositi of the Hubli pedigree. In this pedigree however the ratio of the affected to normals supports the Mendelian mode of inheritance (Figs. 3 & 8-9). The aforesaid interpretation is subject to the association of the inheritance pattern of the trait of polydactyly with a number of other genetic syndromes besides the limited number of affected individuals in the pedigrees (Smith et al. 1963; Temtamy and McKusick 1969).

The proposita affected by atrophied toes and nails does not seem to have a parallel in this country as shown by the examination of the published literature (Figs. 4 & 10). Her affected feet present a swollen appearance giving the impression that the woman was suffering from a serious disease whereas our enquiries revealed that she was a perfectly normal individual. The mode of inheritance of this abnormality is not clear at this stage of our knowledge due to limitations of its absence in other generations of the pedigree and lack of earlier works. The issue may be resolved by systematic future research.



**Fig. 8. Polydactylous right hand**

The lobster clawed hands and syndactylous feet of the girl in the Hubli pedigree constitute an unique instance of a serious deformity (Figs. 5 & 11-12). The lobster claw deformity affecting both hands and feet with a hereditary history of five generations was reported perhaps for the first time in humans by Lewis and Embleton (1908). Subsequently, a pedigree of cleft hand involving an affected woman and her affected children by four different normal fathers was reported by Curt Stern (1960). The affected children had their hands as well as feet with the deformity unlike their mother. Three Yugoslavian families investigated by Zergollern (1978) also had this syndrome – the first one with an affected sister and brother and the other two with one affected child each.



**Fig. 9. Polydactylous left hand**



**Fig. 10. Atrophied toes and nails**

The anomaly in the first family was considered to be autosomal recessive type due to negative family history, non-consanguinity and normal progeny of the affected persons, while in the other two families it was inferred that the affected were due to fresh mutation of an autosomal dominant trait. In India too this syndrome was reported by Verma et al. (1976) who believe that the deformity is an autosomal recessive trait, and by Kumbhani (1991) who, based on the occurrence of the affliction in both hands and feet of a woman and her five children born of a normal father, thinks that the mode of inheritance was autosomal dominant.

The proposita with lobster clawed hands is in the IV generation besides the reported case of a boy with similar deformity in the V generation. All the earlier generations are devoid of the abnormality. The abnormality seems to be due to an autosomal dominant gene with variable expressivity and penetrance in right and left hand digits of the same individual. The differences in the expressivity of the defect are apparently due to the influence of intrinsic and extrinsic factors (Figs. 5 & 11).

The above proposita also presents the anomaly of syndactylous toes which is a variable trait (Figs. 5 & 12). The condition of webbing shows sex-linked inheritance in some families.



**Fig. 11. Lobster clawed hands**

As it occurs in either sex, the trait may be caused by an autosomal recessive gene (Winchester 1969). In a western Indian kindred investigated by Malhotra (1963) there are 33 direct descendants of a syndactylous man and phenotypically normal wife. Two of their male children in the II generation are both clinodactylous and syndactylous and two of the female grand children in the III generation are syndactylous. He believes that both these traits are transmitted, independently of each other, as dominants with incomplete penetrance. In our example, the family history is negative for both cleft hands and webbed feet and their occurrence in one and the same individual is a sheer coincidence. The webbing of feet may have been caused by an autosomal dominant gene with variable expressivity and penetrance.



**Fig. 12. Syndactylous feet**

This individual-level study makes it clear that the genetic defects in general are all-pervasive in nature occurring in all ethnic groups and are not limited to particular racial or community groups and families. Many of these disorders place considerable social stigma on the concerned communities or families while others indeed endanger their health and physical well-being. These thus call for taking appropriate measures ranging from curation, therapy, management to prevention. It is against this background that a

systematic country-wide population survey has to be organised as a multidisciplinary pursuit to establish the frequencies of different defects by age-groups, communities, regions and so on.

## REFERENCES

- Bhatnagar SM, Kothari ML, Mehta LA 1986. *Essentials of Human Genetics*. Third Edition, Bombay: Orient Longman Ltd.
- Jagannatha Reddy D 1978. Prepare to meet new challenges in the changing scene of medical practice. In: Ishwar C. Verma (Ed): *Medical Genetics in India*, Volume I, Pondicherry: Auroma Enterprises pp.1-4.
- Kumbnani HK 1991. Lobster claw – its occurrence and genetic counselling. Presented at the *XVI Annual Conference of Indian Society of Human Genetics* held at Tirupati from January 18-20, Souvenir; Programme-Cum-Abstracts, p.21.
- Lewis T, Embleton D 1908. Split-hand and split-foot deformities: Their types, origin and transmission. *Diometrika*, **VI** (i).
- Malhotra KC 1963. Syndactyly and clinodactyly within an Indian Kindred. *Journal of Heredity*, **LIV** (5): 219-220.
- Malhotra KC 1964. A pedigree of polydactyly. *The Anthropologist*, **8**: 1-4.
- Narahari S 2003. A case report of Genetic malformations in a Jatapu tribal girl of Andhra Pradesh. *Int J Hum Genet*, **3**(3): 191-194.
- Rami Reddy V, Naidu GP, Reddy BKC 1986. A pedigree of polydactyly, clinodactyly and hare-lip from a Karnataka village. *Ind J Phys Anthropol & Hum Genet*, **12**(1): 69-74.
- Roberts JAF 1974. *An Introduction to Medical Genetics*. First E.L.B.S. Edition, Oxford: Oxford University Press.
- Smith DW, Patau K, Therman E, Inhorn SL, Demars RI 1963. The  $D_1$  trisomy syndrome. *J Pediat*, **62**: 326-341.
- Stern, Curt 1960. *Principles of Human Genetics*. Second Edition, Tokyo: Toppan Company Limited.
- Temtam S, McKusick VA 1969. Synopsis of hand malformations with particular emphasis on genetic factors. *Birth Defects: Orig Art Ser*, **5**: 125-184
- Verma IC 1978. *Medical Genetics in India*. Volume 1. Pondicherry: Auroma Enterprises.
- Verma IC, Joseph R, Bhargava S, Mehta, S 1976. Split-hand and split-foot deformity inherited as an autosomal recessive trait. *Clin Gen*, **9**: 8-14.
- Winchester AM 1969. *Genetics: A Survey of the Principles of Heredity*. Third Edition. Calcutta: Oxford & IBH Publishing Co.
- Woolf CM, Woolf RM 1970. A genetic study of polydactyly. *Am J Hum Genet*, **22**: 75-88.
- Zergollern Lj 1978. Genetic counselling in the prevention of skeletal malformations. In: Ishwar C. Verma (Ed): *Medical Genetics in India*, Volume 1, Pondicherry: Auroma Enterprises pp.209-213.