

5467/80

IC/80/158

**INTERNATIONAL CENTRE FOR
THEORETICAL PHYSICS**

GEON-TYPE SOLUTIONS
OF THE NON-LINEAR HEISENBERG-KLEIN-GORDON EQUATION

Eckehard W. Mielke

and

Reinhard Scherzer



**INTERNATIONAL
ATOMIC ENERGY
AGENCY**



**UNITED NATIONS
EDUCATIONAL,
SCIENTIFIC
AND CULTURAL
ORGANIZATION**

1980 MIRAMARE-TRIESTE

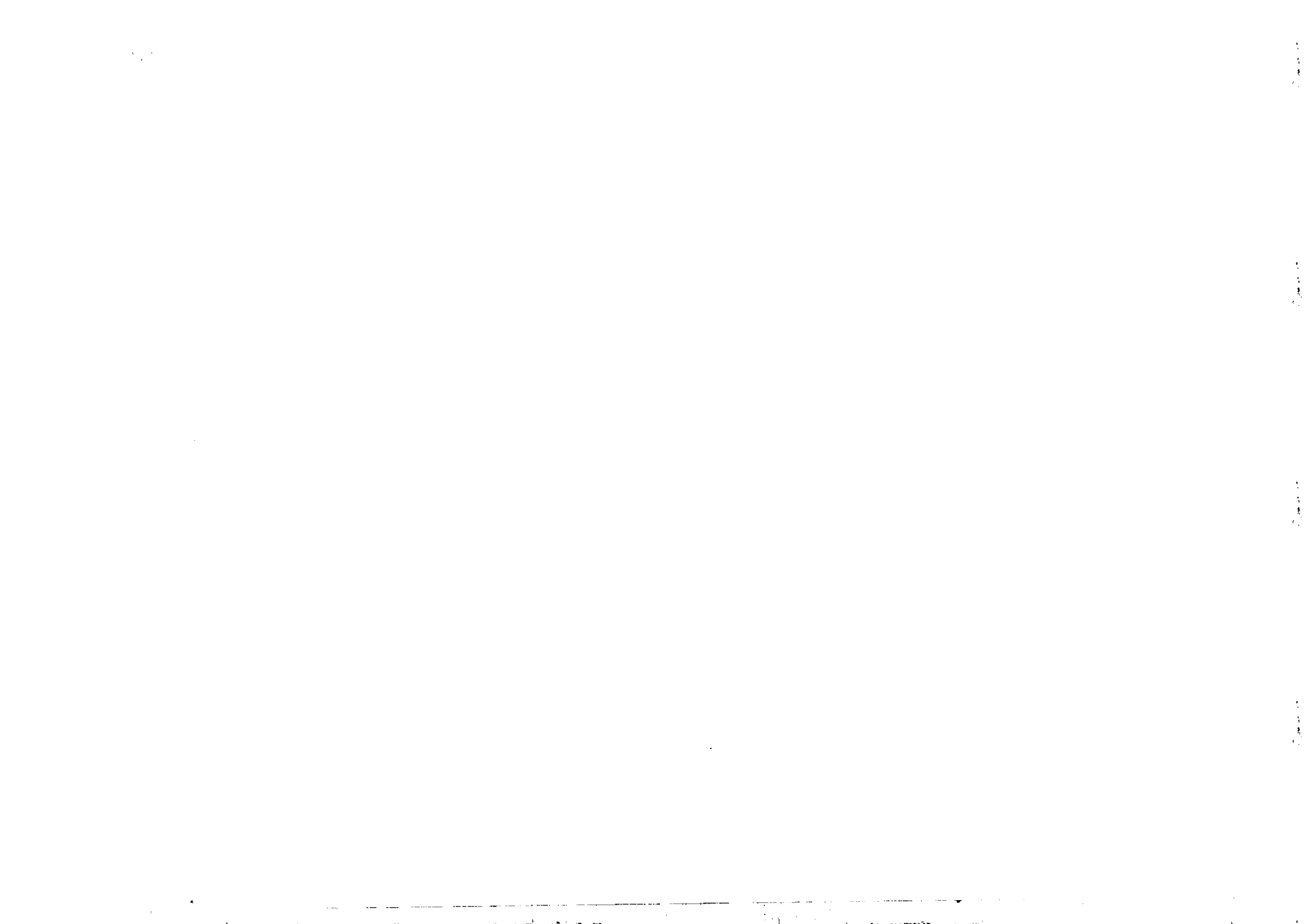

International Atomic Energy Agency
and
United Nations Educational Scientific and Cultural Organization

INTERNATIONAL CENTRE FOR THEORETICAL PHYSICS

GEON-TYPE SOLUTIONS OF THE NON-LINEAR HEISENBERG-KLEIN-GORDON EQUATION *

Eckehard W. Mielke
International Centre for Theoretical Physics, Trieste, Italy,

and

Reinhard Scherzer
Institut für Reine und Angewandte Kernphysik
der Christian-Albrechts Universität Kiel, 2300 Kiel,
Federal Republic of Germany.

MIRAMARE - TRIESTE

October 1980

* To be submitted for publication.



ABSTRACT

As a model for an "unitary" field theory of extended particles we consider the non-linear Klein-Gordon equation - associated with a "squared" Heisenberg-Pauli-Weyl non-linear spinor equation - coupled to strong gravity. Using a stationary spherical ansatz for the complex scalar field as well as for the background metric generated via Einstein's field equation, we are able to study the effects of the scalar self-interaction as well as of the classical tensor forces. By numerical integration we obtain a continuous spectrum of localized, gravitational solitons resembling the geons previously constructed for the Einstein-Maxwell system by Wheeler. A self-generated curvature potential originating from the curved background partially confines the Schrödinger type wave functions within the "scalar geon". For zero angular momentum states and normalized scalar charge the spectrum for the total gravitational energy of these solitons exhibits a branching with respect to the number of nodes appearing in the radial part of the scalar field. Preliminary studies for higher values of the corresponding "principal quantum number" reveal that a kind of fine splitting of the energy levels occurs, which may indicate a rich, particle-like structure of these "quantized geons".

1. INTRODUCTION

A fundamental theory of matter based on the quark hypothesis ¹⁾ has to accommodate an in-built mechanism of (at least partial) confinement of the constituent field in stable particles, otherwise they should be observable at some detectable rate ²⁾. In order to circumvent the Pauli exclusion principle, these fundamental fermion fields are assumed to obey parastatistics, or equivalently, have to carry, besides, flavour, additional colour ³⁾ degrees of internal freedom. These colour models are distinguished by the binding mechanism of quarks in hadrons, ^{i.e.} whether this is mediated by scalar ⁴⁾ vector (see e.g. Ref.5) or tensor "gluons" ^{6),7)}.

In "quantum chromodynamics" (QCD) ⁵⁾, nowadays the most prominent model for strong interactions, the dynamics of the mediating vector gluons is determined by an action modelled after Maxwell's theory of electromagnetism. The resulting model is a gauge theory of the Yang-Mills type ⁸⁾. However it is known ⁹⁾ that in such sourceless non-abelian gauge theories there are no classical glueballs which otherwise would be an indication for the occurrence of confinement in the quantized theory. (The phenomenological consequences of the possible existence of glueballs in QCD have been discussed by Robson ¹⁰⁾.) The reason simply being that nearby small portions of the Yang-Mills fields always point in the same direction ⁱⁿ internal space and therefore must repel each other as like charges. Nevertheless, vector gauge fields might be an important ingredient of any model in order to explain saturation ⁶⁾.

The confinement itself, according to the proposals of an unconventional scheme termed "colour geometrodynamics" (CGMD) ^{11),12),13)} may be achieved by strongly ^{14),15),16)} interacting massless tensor gluons, their dynamics presumably being determined by Einstein-type field equations. CGMD is a $GL(2N, C)$ gauge model in curved space-time which may be regarded as a generalization of Einstein's gravity theory. The latter corresponds to a gauging of the covering group $SL(2, C)$ of the Lorentz group. Since CGMD is, in general, based on a Riemann-Cartan space-time ¹⁷⁾, Cartan's notion of torsion is known ¹⁷⁾ to induce non-linear spinor terms into the Dirac equation. This has a profound effect on the "fundamental" spinor fields

$$\psi = \{ \psi^{(q)}(x) \mid q = 1, \dots, N \} \quad (1.1)$$

distinguished by N colour (or flavour) internal degrees of freedom. It can also be shown for this $GL(2N, C)$ gauge invariant generalization¹²⁾ that these quark type fields have to satisfy the Heisenberg-Pauli-Weyl^{18),19),20)} non-linear spinor equation

$$\{iL^\mu \nabla_\mu - \frac{3\epsilon}{8} \ell^{*2} \psi L^5 \gamma_\mu \psi L^5 L^\mu - \mu c / \hbar\} \psi = 0 \quad (1.2)$$

generalized to a curved²¹⁾ space-time (compare also with Ivanenko²²⁾). Here L^μ are space-time dependent generalizations of the Dirac matrices γ^α tensored with the $U(n)$ vector operators λ^j (generalized Gell-Mann matrices). Essentially the modified Planck length

$$\ell^* \equiv (8\pi\hbar G_S / c^3)^{1/2} = (8\pi)^{1/2} \hbar / c M^* \approx 10^{-13} \text{ cm} \quad (1.3)$$

of strong gravity^{14),15),16)} occurs also as the coupling constant of the self-interaction in (1.2).

If we transfer the ideas of Mach and Einstein to the microcosmos, the curving-up of the hadronic background metric should be self-consistently produced by the stress energy content $T_\mu^\nu(\psi)$ of the spinor fields (1.1) via the Einstein equations

$$G_\mu^\nu + \int_\mu^\nu \Lambda_{\text{conv}} = - \frac{\ell^{*2}}{\hbar c} T_\mu^\nu \quad (1.4)$$

with "cosmological term" (we employ the sign conventions of Tolman²³⁾). In this new geometrodynamical model extended particles owning internal symmetries should be classically described by objects which closely resemble the geons and wormholes of Wheeler²⁴⁾. In some sense this approach is also related to the issue to which Einstein and Rosen addressed their 1935 paper²⁵⁾.

"Is an atomistic theory of matter and electricity conceivable which, while excluding singularities in the field, makes use of no other fields than those of the gravitational field ($g_{\mu\nu}$) and those of the electromagnetic field in the sense of Maxwell (vector potentials φ_μ)?"

The geon, i.e. a "gravitational electromagnetic entity" was originally devised by Wheeler²⁴⁾ to be a self-consistent, non-singular solution of the otherwise sourcefree Einstein-Maxwell equations having persistent large scale features. Such a geon provides a well-defined model for a classical "body" in general relativity. If spherically symmetric geons would stay completely stable objects they could acquire the possibility to derive their equations of motions solely from Einstein's field equations²⁶⁾ without the need to introduce field singularities. In a sense this approach also embodies the goals of the so-called unitary field theory^{27),28)}.

Geons, as we are using the term, are gravitational solutions, which are held together by self-generated gravitational forces and are composed of localized fundamental classical fields. The coupling of gravity to neutrino fields has already been considered by Brill and Wheeler²⁹⁾. The latter work lays the appropriate groundwork for an extension of their analysis to non-linear spinor geons satisfying the combined equations (1.2) and (1.4). In this paper, however, we have avoided algebraic complications resulting from the spinor structure as well as from the internal symmetry by considering rather non-linear scalar fields coupled to gravity. In order to maintain a similar dynamics we assume - as in a previous paper (Ref.30, hereafter referred to as I) - a self-interaction of these scalar fields which can be formally obtained by "squaring" the fundamental spinor equation (1.2). "Linear" Klein-Gordon geons have been previously constructed³¹⁾. However, we view the additional non-linearity of the scalar fields as an important new ingredient for our model.

The precise set-up of this theory is given in Sec.II. For the intended construction of localized geons, the stationary, spherical ansätze of I are employed for the scalar fields, whereas the metric is taken in its general spherically symmetric canonical form. As in the case of a prescribed Schwarzschild background - analysed in I - the curved space-time effects the resulting Schrödinger equation for the radial function essentially via an external gravitational potential.

The stress energy content of these scalar solutions determines the curvature via Einstein's field equations. In Sec.II we review the spherical symmetric case and include also a method which enables us to incorporate non-zero angular momentum states into this framework by averaging the stress energy of these scalar fields over a spherical shell.

Our geons contain a fixed (quantized) scalar charge. By imposing this restriction in Sec.V we not only fix an otherwise undetermined scale of our geons but may also increase their stability. The main concern of Sec.V is,

however, to contrast two notions of energy for our gravitational solitons, 1) the field energy of the general relativistic scalar waves and 2) the total gravitational energy of such an isolated system³²⁾. In order to probe our concepts we construct in Sec.VI a simplified geon by considering radially constant scalar solutions owning the particular constants admitted by the non-linear self-interaction. Outside a ball of radius \mathfrak{S}_B the scalar fields are discontinuously set to zero. Although this procedure is rather artificial, we thereby obtain a "bag"-like³³⁾ object having inside a portion of an Einstein microcosmos and outside a Schwarzschild manifold as background space-time.

In general, the resulting system of three coupled non-linear equations for the radial parts of the scalar and the (strong gravitational) tensor fields has to be solved numerically. In order to specify the starting values for the ensuing numerical analysis we derive in Sec.VII asymptotic solutions at the origin and at spatial infinity. Sec.VII is then devoted to a discussion of the numerical results. Preliminary speculations are offered with the aim to interpret particles as "quantum geons".

Sec.VIII concludes the paper with a prospective overview of other developments concerning "gravitational solitons".

II. THE MODEL

Following the outline given in the Introduction we may consider as a simplified model a theory consisting of N complex scalar fields

$$\varphi = \{ \varphi^q(x) \mid q = 1, \dots, N \}. \quad (2.1)$$

Their dynamics is governed by the Lagrangian density

$$\mathcal{L}_{\text{HKG}} = \frac{\hbar^2}{2\mu} \sqrt{|f|} \left[f^{\mu\nu} (\partial_\mu \varphi^*) (\partial_\nu \varphi) - U(|\varphi|^2) \right] \quad (2.2)$$

defined on curved pseudo-Riemannian space-time with metric tensor $f_{\mu\nu}$. In order to obtain a similar dynamical problem as in the non-linear spinor theory given by (1.2) the self-interaction potential

$$U(|\varphi|^2) = (\mu c/\hbar)^2 \varphi^* \varphi - \frac{3\epsilon\kappa c}{16\hbar} \ell^2 (\varphi^* \varphi)^2 + \frac{3\bar{\epsilon}}{256} \ell^4 (\varphi^* \varphi)^2, \quad \epsilon, \bar{\epsilon} = 0, \pm 1 \quad (2.3)$$

is chosen to be similar to that used in I. Such a model has recently been treated in 1+1 dimensions according to quantum field theoretical methods³⁴⁾. Variation for $\delta\mathcal{L}_{\text{HKG}}/\delta\varphi^*$ yields the non-linear Klein-Gordon equation

$$[\square + dU/d(|\varphi|^2)] \varphi = 0, \quad (2.4)$$

where

$$\square = \frac{1}{\sqrt{|f|}} \partial_\mu (f^{\mu\nu} \sqrt{|f|} \partial_\nu) \quad (2.5)$$

denotes the generally covariant Laplace-Beltrami operator. When (2.4) is explicitly written^{out} for the choice (2.3) of the self-coupling it will be referred to as the non-linear Heisenberg-Klein-Gordon equation

$$[\square - \frac{3\epsilon\kappa c}{8\hbar} \ell^2 |\varphi|^2 + \frac{3\bar{\epsilon}}{256} \ell^4 |\varphi|^4 + (\mu c/\hbar)^2] \varphi = 0 \quad (2.6)$$

In I it has been shown that (2.6) is formally similar to that obtained by "squaring" the fundamental spinor equation (1.2). This is part of the motivation for considering a $|\varphi|^6$ -term in the corresponding Lagrangian density (2.2).

Although the resulting quantum field theory, contrary to the $|\varphi|^4$ model, would not be renormalizable according to standard criteria of perturbation theory we include in this paper the additional $|\varphi|^6$ self-interaction term. For a semiclassical approach it may be instrumental for the construction of quasistable, spherically symmetric and localized solutions. At least in flat space-time, Anderson³⁵⁾ has shown by means of a phase-space analysis that for

$$-\infty < B_{\text{And.}} \equiv \frac{\bar{\epsilon}}{4} (1 - \omega^2) < \frac{3}{16} \quad (2.7)$$

particle-like (stable) solutions can exist. ω is the ratio between dynamical mass and the "bare" mass μ of this model (see Sec. III). Intuitively, we suspect that the stability of these solutions (and possibly also their degree of "confinement") is enhanced by the attractive forces exerted on them via the coupling to strong tensor gluons^{11),7)}. Geometrically speaking, this would correspond to a curved background manifold. In our model this curving up of the background is self-consistently produced from the stress energy tensor³⁶⁾ (MTW, p.504)

$$T_{\mu\nu}(\varphi) \equiv -\frac{2}{\sqrt{|f|}} \frac{\delta \mathcal{L}_{HKG}}{\delta f^{\mu\nu}} = 2 \delta(|f|^{-1/2} \mathcal{L}_{HKG}) / \delta f^{\mu\nu} - f_{\mu\nu} |f|^{-1/2} \mathcal{L}_{HKG} \quad (2.8)$$

of the scalar fields φ via Einstein's field equations (1.4). In effect, our geometrodynamical model is then completely determined by the Lagrangian density

$$\mathcal{L}_{GMD} = \frac{\hbar c}{2\pi^2} \sqrt{|f|} (R - 2\Lambda_{conv.}) + \mathcal{L}_{HKG} \quad (2.9)$$

since (2.6) and (2.9) can be derived from it by a variation for $\delta \mathcal{L}_{GMD} / \delta \varphi^*$ and for $\delta \mathcal{L}_{GMD} / \delta f^{\mu\nu}$.

III. SPHERICAL SCALAR WAVES IN A CURVED BACKGROUND

As a semiclassical model for a particle we are considering spherical geon type^{24),37)} solutions which minimize (2.9). More precisely, we are looking for spherical wave configurations which solve the HKG equation (2.6) in a static, spherically symmetric background space-time which in turn is determined by (1.4).

As is well known³⁶⁾ (see, e.g. MTW, p.594 and box 23.3) a canonical form of the general (dimensionless) line element for this background reads:

$$d\bar{s}^2 \equiv \frac{2\pi}{\ell^*} ds^2 = \frac{2\pi}{\ell^*} f_{\mu\nu} dx^\mu dx^\nu = \frac{2\pi}{\ell^*} e^\nu c^2 dt^2 - e^\lambda ds^2 - \xi^2 (d\theta^2 + \sin^2\theta d\phi^2) \quad (3.1)$$

if the sign conventions of Tolman²³⁾ are adopted. Here $\nu \equiv \nu(\xi)$ and $\lambda \equiv \lambda(\xi)$ are functions which depend solely on the dimensionless "Schwarzschild type" (MTW, p.721) radial co-ordinate

$$\xi \equiv \frac{\sqrt{2\pi}}{\ell^*} r = \frac{M^* c}{2\hbar} r, \quad r = |\vec{x}| \quad (3.2)$$

The determinant of this metric is given by

$$\sqrt{|f|} = \left(\frac{\ell^*}{\sqrt{2\pi}}\right)^3 c e^{(\nu+\lambda)/2} \xi^2 \sin\theta \quad (3.3)$$

For the construction of spherical scalar waves, we take up the well-known fact that solutions of the free, linear Klein-Gordon equation can be expanded in terms of spherical harmonics $Y_l^m(\theta, \phi)$ which are eigenfunctions

$$\begin{aligned} & [\Delta_2 + L(L+1)] Y_l^m(\theta, \phi) \\ & \equiv \left[\frac{1}{\sin\theta} \partial_\theta (\sin\theta \partial_\theta) + \frac{1}{\sin^2\theta} \partial_\phi^2 + L(L+1) \right] Y_l^m(\theta, \phi) = 0 \end{aligned} \quad (3.4)$$

of the Laplace operator Δ_2 on 2-sphere S^2 . Although a non-linear theory in general does not respect such an expansion, the non-linear terms of the field equation (2.6) admit the two distinct separation ansätze of I:

$$\varphi^{(q)} = \frac{4}{\ell} (\mu c / \hbar)^{1/2} \left(\frac{4\pi}{3N}\right)^{1/2} e^{-it\omega\mu c^2/\hbar} \times \begin{cases} R_l^\omega(\xi) Y_l^{q-l-1}(\theta, \phi) & \text{if } N = 2L+1 \\ R_0^\omega(\xi) Y_0^0(\theta, \phi) & \text{elsewhere} \end{cases} \quad (3.5)$$

Due to the familiar addition theorem³⁸⁾ (Landau and Lifschitz, §26)

$$\sum_{m=-l}^l Y_l^m(\theta, \phi)^* Y_l^m(\theta, \phi) = \frac{2l+1}{4\pi} \quad (3.7)$$

a self-interaction given by a polynomial in $|\varphi|^2 = \sum_{q=1}^n \varphi^{(q)*} \varphi^{(q)}$ remains spherically symmetric as required by separability.

In order to see how space-time curvature affects the wave equation it is instructive to define

$$R_l^\omega(\xi) \equiv \frac{1}{\xi} F_l^\omega(\xi) \quad (3.8)$$

(in some equations below abbreviated by R or F, respectively) and to introduce Wheeler's ³⁶⁾ "tortoise co-ordinate" ξ^* (MTW, p.663) via the differential form ³⁷⁾

$$d\xi^* \equiv e^{(\lambda-\nu)/2} d\xi. \quad (3.9)$$

Then the line element (3.1) takes the form

$$d\bar{s}^2 = e^\nu \left(\frac{2\pi}{l^{*2}} c^2 dt^2 - d\xi^{*2} \right) - \xi^2 (d\theta^2 + \sin^2\theta d\phi^2). \quad (3.10)$$

It resembles the metrical ground form of a space-time with two conformally flat portions. Then a kind of "conformal change" ³⁹⁾ of the Laplace-Beltrami operator (2.4) may be calculated with the formal result

$$\begin{aligned} \frac{l^{*2}}{2\pi} \xi \square \frac{1}{\xi} &= e^{-\nu} \left(\frac{l^{*2}}{2\pi c^2} \partial_t^2 - \partial_{\xi^*}^2 \right) \\ &- \frac{1}{\xi^2} \left[\frac{1}{\sin\theta} \partial_\theta (\sin\theta \partial_\theta) + \frac{1}{\sin^2\theta} \partial_\phi^2 \right] \\ &+ \frac{1}{\xi} e^{-(\nu+\lambda)/2} \left(\partial_\xi e^{(\nu-\lambda)/2} \right) \end{aligned} \quad (3.11)$$

With respect to the new co-ordinate ξ^* and the Schrödinger type wave function $F_l^\omega(\xi^*)$, the structure of the Laplace-Beltrami operator is similar to that of a conformally flat Klein-Gordon operator with an external potential.

Consequently, the stationary ansätze (3.5) and (3.7) together with the property (3.11) cast the HKG equation (2.6) into the Schrödinger type equation

$$\begin{aligned} &[\partial_{\xi^*}^2 - V_{\text{eff}}^L(\xi^*)] F \\ &= \frac{1}{\beta^2 N^2} e^\nu \left(\frac{\bar{\epsilon}}{\xi^4} F^4 - \frac{2\epsilon}{\xi^2} F^2 + 1 - e^{-\nu} \omega^2 \right) F \end{aligned} \quad (3.12)$$

with an effective curvature potential (compare with MTW ³⁶⁾, p.868) implicitly given by

$$V_{\text{eff}}^L(\xi^*) = \frac{e^\nu}{\xi^2} \left[l(l+1) - \frac{1}{2} \xi e^{-\lambda} \partial_\xi (\lambda - \nu) \right]. \quad (3.13)$$

Here and in the following the factor

$$\beta \equiv \frac{M^*}{2N\mu} \quad (3.14)$$

denotes the dimensionless ratio between the Planck mass M^* and the "bare mass" μ of the N "constituent" fields. So far for the formal aspects of the theory. For the ensuing numerical calculations, however, it is more convenient to use the equivalent radial equation

$$\begin{aligned} &R'' + \left[\frac{1}{2} \partial_{\xi^*} (\nu - \lambda) + \frac{2}{\xi} \right] R' - l(l+1) \frac{e^\lambda}{\xi^2} R \\ &= \frac{e^\lambda}{\beta^2 N^2} \left(\bar{\epsilon} R^4 - 2\epsilon R^2 + 1 - e^{-\nu} \omega^2 \right) R \end{aligned} \quad (3.15)$$

written explicitly in terms of ξ . (The dash denotes differentiation with respect to ξ .) It may be obtained from (3.12) and (3.13) by resubstitutions, or more directly from (2.6) and the original ansätze (3.5) and (3.6) founded on the background (3.1). It generalizes Eq.(3.9) of Kaup ³¹⁾ derived there from a linear Klein-Gordon equation.

IV. THE EINSTEIN FIELD EQUATIONS

By applying Machian ideas to the microcosmos, the strong gravitational background will be determined from the stress energy content of the scalar waves via the Einstein equations (1.4).

With respect to the diagonal metric of (3.1) these equations reduce to (see Tolman²³), p.242)

$$-e^{-\lambda} \left(\frac{\nu'}{g} + \frac{1}{g^2} \right) + \frac{1}{g^2} - \Lambda = \frac{l^{*4}}{2\pi \hbar c} T_r^r \quad (4.1)$$

$$\begin{aligned} -e^{-\lambda} \left(\frac{\nu''}{2} - \frac{\lambda' \nu'}{4} + \frac{\nu'^2}{4} + \frac{\nu' - \lambda'}{2g} \right) - \Lambda \\ = \frac{l^{*4}}{2\pi \hbar c} T_\theta^\theta = \frac{l^{*4}}{2\pi \hbar c} T_\phi^\phi \end{aligned} \quad (4.2)$$

and

$$e^{-\lambda} \left(\frac{\lambda'}{g} - \frac{1}{g^2} \right) + \frac{1}{g^2} - \Lambda = \frac{l^{*4}}{2\pi \hbar c} T_0^0 \quad (4.3)$$

Here

$$\Lambda \equiv \frac{l^{*2}}{2\pi} \Lambda_{conv.} \quad (4.4)$$

denotes a dimensionless "cosmological" constant and the dash again means differentiation with respect to g .

Although this set of equations may look like an overdetermined system, a simple argument shows that this is not the case.

According to second-order variational principles which can be generalized to a curved space-time⁴⁰⁾ there exist the conservation law $\nabla_\nu T_\mu^\nu = 0$ for the stress energy tensor (2.8) provided that the matter field equations (2.4) hold. In our case, this law relates the two tangential tensions $T_\theta^\theta = T_\phi^\phi$ to the radial tensions T_r^r , T_0^0 and $d T_r^r / dr$. This knowledge of $T_\theta^\theta = T_\phi^\phi$ is not instrumental for the determination of the

gravitational fields from the field equation (2.9). Due to the contracted Bianchi identity $\nabla_\nu G_\mu^\nu = 0$ there exists the same relation between the diagonal elements of the Einstein tensor G_μ^μ . Therefore it is enough to consider the two remaining equations (4.1) and (4.3) only. (Ref.41, p.488).

For the supposed spherically symmetric background (3.1) we notice that the non-trivial ansatz (3.5) would lead to an inconsistency in the gravitational field equations. The reason being that the corresponding stress energy tensor (2.8), in the scalar case given by

$$T_\mu^\nu = \frac{\hbar^2}{\mu} (\partial_\mu \varphi^*) (\partial^\nu \varphi) - \delta_\mu^\nu |f|^{-1/2} \mathcal{L}_{HKG}, \quad (4.5)$$

would also depend on the angular distribution of the solutions, contrary to the Einstein tensor.

For localized solutions the spherical asymmetry of the scalar waves (3.5) is expected to be negligible sufficiently far away from the centre of the geon. Therefore it is physically justifiable not to discard ansatz (3.5) but rather consider the Einstein equations (4.1)-(4.3) with respect to an averaged stress energy tensor $\langle T_\mu^\nu \rangle$ as proposed by Power and Wheeler⁴¹⁾ (see p.488). Suitable is an average $\langle \rangle$ over a spherical shell defined by the property

$$\langle |Y_l^m|^2 \rangle \equiv \frac{1}{4\pi} \int_0^{2\pi} \int_0^\pi |Y_l^m(\theta, \phi)|^2 \sin\theta d\theta d\phi = \frac{1}{4\pi} \quad (4.6)$$

The evaluation of $\langle T_\mu^\nu \rangle$ will be facilitated by employing the identity

$$\begin{aligned} \langle |\partial_\theta Y_l^m|^2 + \frac{1}{\sin^2\theta} |\partial_\phi Y_l^m|^2 \rangle + \langle Y_l^{m*} \Delta_2 Y_l^m \rangle \\ = \langle \frac{1}{\sin\theta} \partial_\theta (Y_l^{m*} \sin\theta \partial_\theta Y_l^m) + \frac{1}{\sin^2\theta} \partial_\phi (Y_l^{m*} \sin\theta \partial_\phi Y_l^m) \rangle \\ = \frac{1}{4\pi} \int_{S^2} \partial^k (Y_l^{m*} \sin\theta \partial_k Y_l^m) d^2x = 0 \end{aligned} \quad (4.7)$$

which results from the application of Stoke's theorem.

With respect to the ansätze (3.5) and (3.6) the averaged radial tensions come out as

$$\begin{aligned} \langle T_r^r \rangle &= \frac{16}{3\beta^2 N^2} \frac{2\pi \hbar c}{\ell^2 \ell^{*2}} \omega^2 e^{-\nu} R^2 - \left\langle \frac{\mathcal{L}_{HKG}}{\sqrt{|f|}} \right\rangle \\ &\equiv \frac{2\pi \hbar c}{\ell^{*4}} \bar{\rho}_{00} \end{aligned} \quad (4.8)$$

and

$$\begin{aligned} \langle T_r^r \rangle &= -\frac{16}{3} \frac{2\pi \hbar c}{\ell^2 \ell^{*2}} e^{-\lambda} (R')^2 - \left\langle \frac{\mathcal{L}_{HKG}}{\sqrt{|f|}} \right\rangle \\ &\equiv -\frac{2\pi \hbar c}{\ell^{*4}} \bar{p}_0 \end{aligned} \quad (4.9)$$

where the spherical average of the Lagrange function is explicitly given by

$$\begin{aligned} \left\langle \frac{\mathcal{L}_{HKG}}{\sqrt{|f|}} \right\rangle &= \frac{8}{3\beta^2 N^2} \frac{2\pi \hbar c}{\ell^2 \ell^{*2}} \left[(\omega^2 e^{-\nu} - \frac{\mathcal{L}(\mathcal{L}+1)}{\mathcal{S}^2} \beta^2 N^2 - 1) R^2 \right. \\ &\quad \left. - \beta^2 N^2 e^{-\lambda} (R')^2 + \epsilon R^4 - \frac{\bar{\epsilon}}{3} R^6 \right] \end{aligned} \quad (4.10)$$

In order to bring the radial Einstein equations in close analogy with those known for a perfect fluid (Ref.23, p.244) we may formally introduce in (4.8) the dimensionless proper density $\bar{\rho}_{00}$ of the scalar field. It turns out to be explicitly given by

$$\begin{aligned} \bar{\rho}_{00} &= \frac{8}{3\beta^2 N^2} \frac{\ell^{*2}}{\ell^2} \left[(\omega^2 e^{-\nu} + \frac{\mathcal{L}(\mathcal{L}+1)}{\mathcal{S}^2} \beta^2 N^2 + 1) R^2 \right. \\ &\quad \left. + \beta^2 N^2 e^{-\lambda} (R')^2 - \epsilon R^4 + \frac{\bar{\epsilon}}{3} R^6 \right] \end{aligned} \quad (4.11)$$

Furthermore, the dimensionless proper "hydrostatic pressure" \bar{p}_0 of a scalar field can (implicitly) be defined by (4.9).

By subtracting (4.1) from (4.3) and evaluating the combination

$$\begin{aligned} \bar{\rho}_{00} + \bar{p}_0 &= \\ &= \frac{16}{3\beta^2 N^2} \frac{\ell^{*2}}{\ell^2} \left[\omega^2 e^{-\nu} R^2 + \beta^2 N^2 e^{-\lambda} (R')^2 \right] \end{aligned} \quad (4.12)$$

we obtain

$$\nu' + \lambda' = (\bar{\rho}_{00} + \bar{p}_0) \mathcal{S} e^\lambda \quad (4.13)$$

whereas in this notation (4.3) is equivalent to

$$\lambda' = (\bar{\rho}_{00} + \mathcal{L}) \mathcal{S} e^\lambda - \frac{1}{\mathcal{S}} e^\lambda + \frac{1}{\mathcal{S}} \quad (4.14)$$

These equations are generalizations of those considered by Kaup³¹⁾ for a linear and e.g. by Kodama *et al.*⁴²⁾ for a non-linear Klein-Gordon field.

It should be noted that (4.14) is a linear differential equation in $e^{-\lambda}$. As is well known the general formal solution can be written as

$$e^{-\lambda} = 1 - \frac{\alpha(\mathcal{S})}{\mathcal{S}} - \frac{\mathcal{L}}{3} \mathcal{S}^2 \quad (4.15)$$

where

$$\alpha(\mathcal{S}) = \int_0^{\mathcal{S}} \bar{\rho}_{00} x^2 dx \quad (4.16)$$

denotes a mass function. The meaning of the latter terminology will be illuminated if we consider the Einstein equations outside the region where "matter" fields vanish, i.e. $R = 0$ in our case. Then the non-linear equations (4.13) become linearized and the vacuum Einstein equations admit the (with respect to the canonical metric (3.1)) unique set of exact solutions

$$e^\nu = e^{-\lambda} = 1 - \frac{\alpha}{3} - \frac{1}{3} \beta^2 \quad (4.17)$$

They describe the exterior Schwarzschild-de Sitter geometry for a mass distribution located at the origin. Here $\alpha \equiv \alpha(\infty)$ is the parameter measuring the gravitational mass αM^* at spatial infinity.

V. GRAVITATIONAL ENERGY OF GEONS WITH QUANTIZED CHARGE

In order to associate some quantum meaning to the time-dependent localized solutions of the HKG equation the Bohr-Sommerfeld quantization rules may be imposed. For a field theory with infinitely many degrees of freedom this semiclassical quantization condition⁴³⁾ reads

$$2c \int_{-\pi/2\Omega}^{\pi/2\Omega} dt \int d^3x \sum_{q=1}^N \overline{\Pi}_{(q)} \partial_0 \varphi^{(q)} = \pi k \hbar \quad (5.1)$$

the time integration being performed over the semiperiod $\pi\Omega$ of the solution. In a curved space-time the canonical conjugate field momenta are defined (see, e.g. Fulling⁴⁴⁾) by

$$\overline{\Pi}_{(q)} = \frac{\delta \mathcal{L}_{HKG}}{\delta (\partial_0 \varphi_{(q)})} = \frac{\hbar^2}{2\mu} \sqrt{|f|} f^{0\mu} \partial_\mu \varphi^{*(q)} \quad (5.2)$$

In a static background and for the stationary ansätze (3.2) or (3.3) owing the semiperiod $\pi\Omega = -\omega \mu c^2 / \hbar$ it is not difficult to see that the Bohr-Sommerfeld condition (5.1) is equivalent (see also Ref.45, Sec.3.6) to the charge quantization

$$Q(\varphi) = k e, \quad k = 1, 2, \dots \quad (5.3)$$

where

$$Q(\varphi) = \frac{e \hbar}{2 \mu c} i \int d^3x \sqrt{|f|} f^{0\mu} [\varphi^* \partial_\mu \varphi - (\partial_\mu \varphi^*) \varphi] \quad (5.4)$$

in a curved space-time is the conserved total charge of the complex scalar fields. The condition (5.3) may also increase the stability of these "quantum geons"²⁶⁾ provided that this stabilizing device for non-linear semiclassical field theories⁴⁵⁾ applies also in curved space-time.

By insertion of the ansätze (3.2) or (3.3) we obtain the expression

$$\frac{Q(\varphi)}{e} = \frac{32}{3} \frac{\omega}{\beta N} \frac{\ell^{*2}}{\ell^2} \int_0^\infty ds^* F_c^\omega(s^*)^2 = k \quad (5.5)$$

For fixed β and pre-assigned ω this condition normalizes the a priori arbitrary Planck length ℓ^* with regard to the coupling constant ℓ of our non-linear model. On the other hand, if we fix this ratio to be e.g. $\ell^*/\ell = 1$ as we will assume in our numerical calculations, the condition (5.6) determines the physically immaterial initial constant C_{∞} appearing in the asymptotic solutions (7.1) discussed in Sec.VII.

Our normalization (5.4) is the same as that used by Kaup³¹⁾ but deviates from the condition suggested by Feinblum and McKinley⁴⁶⁾.

In a curved space-time the energy concept is known to be rather subtle. Let us recall that for matter fields coupled to gravitation the locally conserved 4-momentum is given by

$$P_\mu = \frac{1}{c} \int_{\text{space-like hypersurface}} (T_\mu{}^\nu + t_\mu{}^\nu) \sqrt{|f|} d\Sigma_\nu \quad (5.6)$$

the integration being performed over a space-like hypersurface. Differently as in the case of flat Minkowski space, in (5.6) the stress-energy pseudotensor $t_{\mu\nu}$ of Landau and Lifshitz³⁶⁾ (MTW, p.466) must be included in order to account for the contribution from the gravitational field.

For a quasistatic isolated system and $\Lambda = 0$ Tolman³²⁾ (see also Ref.23, p.235) has derived the following equivalent expression for its total energy

$$P_0 = \frac{1}{c} \int (2T_0^0 - T_\mu^\mu) \sqrt{|f|} d^3x \quad (5.7)$$

is operationally more useful

This result which is exact in the static case, in particular in numerical calculations, since the volume integral has to be extended only over the region actually occupied by the "matter" fields.

In our construction of localized geons we can satisfy the criteria for the applicability of (5.7) if we require the radial part of the scalar field to be exponentially decreasing in the asymptotic region $\bar{g} \rightarrow \infty$ (see Sec.VII).

Thereby the gravitational background field (3.1) tends sufficiently fast to that of a Schwarzschild geometry given by (4.17) with $\Lambda = 0$. By construction the total mass of our geon is then known to be αM^* (compare with Eq.(6.2) of Ref.41) and the Einstein relation

$$P_0 = \alpha M^* c^2 \quad (5.8)$$

holds in a rest frame.

Using the static background (3.1) and the formal relations (4.8) and (4.9) the Tolman energy (5.7) can be cast into the form

$$P_0 = M^* c^2 \int_0^\infty d\bar{g}^* \bar{g}^2 e^\nu [\bar{g}_{00} + 3\bar{p}_0] \quad (5.9)$$

(Tolman²³⁾, p.248). With respect to a non-linear scalar field theory defined by (2.2), the total energy is equivalent to

$$P_0 = \frac{2\ell^{*3}}{\sqrt{2\pi}} \frac{\hbar^2}{\mu} \int_0^\infty \langle 2f^{00} |\partial_0 \varphi|^2 - \mathcal{U}(|\varphi|^2) \rangle e^{\frac{\nu+\lambda}{2}} \bar{g}^2 d\bar{g} \quad (5.10)$$

the integration over angular variables formally being absorbed in the averages defined earlier by (4.6). After inserting the ansätze (3.5) or (3.6) we obtain the more explicit result

$$P_0 = \frac{32}{3} \frac{\mu c^2}{\beta N} \frac{\ell^{*2}}{\ell^2}$$

$$\times \int_0^\infty d\bar{g}^* \bar{g}^2 e^\nu [2\omega^2 e^{-\nu} - 1 + \epsilon R^2 - \frac{\bar{\epsilon}}{3} R^4] R^2 \quad (5.11)$$

The model dependent ratio ℓ^*/ℓ may be eliminated by the previously derived normalization condition (5.5). Then in view of (3.14) the formula

$$\alpha = \frac{k}{\beta N} \left\{ \omega - \frac{1}{2\omega} \frac{\int_0^\infty d\bar{g}^* \bar{g}^2 e^\nu R^2 (1 - \epsilon R^2 + \frac{\bar{\epsilon}}{3} R^4)}{\int_0^\infty d\bar{g}^* \bar{g}^2 R^2} \right\} > 0 \quad (5.12)$$

finally determines the total gravitational mass αM^* of a "scalar geon with quantized charge". It is interesting to note that gravity alone modifies the "bare" mass μ by $2k\omega$, whereas a "mass renormalization" on this semi-classical level is due to the (non-linear) self-interaction. The relation (5.12) may be contrasted with the curved space-time definition (see, e.g. Ref.44)

$$E = \frac{1}{c} \int T_0^0 \sqrt{|f|} d^3x = \frac{2\ell^{*3}}{\sqrt{2\pi}} \int d\bar{g}^* \bar{g}^2 e^\nu \langle T_0^0 \rangle \quad (5.13)$$

of the field energy of the N scalar "constituent" fields $\varphi^{(q)}$ of the geon without the contributions from the self-consistently generated gravitational field.

Inserting (4.9) together with (4.10) and then substituting the normalization condition (5.4) yields the "mass formula"

$$\frac{E}{c^2} = k \frac{M}{2} \left\{ \omega + \frac{1}{\omega} \left(\int_{s_0}^{\infty} ds^* s^2 R^2 \right)^{-1} \right.$$

$$\left. \times \int_{s_0}^{\infty} ds^* s^2 e^{\nu} R^2 \left[1 + \frac{(l+1)}{s^2} \beta^2 N^2 + \beta^2 N^2 e^{-\lambda} \left(\frac{R'}{R} \right)^2 - \epsilon R^2 + \frac{\bar{\epsilon}}{3} R^4 \right] \right\} \quad (5.14)$$

for $s_0 = 0$. As a precautionary measure for the case that this expression diverges at the origin, we have introduced a "cut-off" length $\rho_0 > 0$ in (5.14), enabling us to study the "regularized" field energy E_{reg} , instead. After subtracting the boundary term

$$E_0 \equiv -\frac{\hbar^2}{2\mu} \int d^3x \partial_a (g^* \sqrt{|f|} f^{ab} \partial_b g) \quad (5.15)$$

from (5.13) and then using the normalization condition (5.5) we may alternatively consider what we call the normalized energy

$$E - E_0 = k \mu c^2 \left\{ \omega + \frac{1}{\omega} \frac{\int_{s_0}^{\infty} ds^* s^2 e^{\nu} \left[\frac{\epsilon}{2} R^2 - \frac{\bar{\epsilon}}{3} R^4 \right]}{\int_{s_0}^{\infty} ds^* s^2 R^2} \right\} \quad (5.16)$$

which should be compared with (4.9) of I. Furthermore, it could be physically interesting to study the binding energy

$$E_{\text{bind}} \equiv \omega \mu c^2 - \frac{\alpha}{N} M^* c^2 = (\omega - 2\alpha\beta) \mu c^2 \quad (5.17)$$

of a scalar particle within a geon as a function of ω and β . Following Ref. 31 we may define it as the energy of a "free" scalar particle from which its energy contribution to the total geon mass at rest is subtracted. A "free" test particle means free of gravitational and self-interaction. In view of (5.16) the corresponding normalized energy is $\omega \mu c^2$ which is the factor appearing in the phase of the ansätze (3.5) or (3.6).

VI. GEON WITH A CONSTANT "BAG-LIKE" CORE

Before we turn to a numerical analysis of the spherical Einstein-Klein-Gordon system it is instructive to study an exact solvable geon containing a constant scalar "core" of radius s_B . In order to obtain this highly idealized configuration one has to note the fact that the non-linear equation (3.15) for the radial distribution of the scalar field φ admits for $l = 0$, besides zero, the constant solution

$$\begin{aligned} (R_c^\omega)^2 &= \frac{\epsilon}{\bar{\epsilon}} (\bar{\omega}) \sqrt{1 - \frac{1}{\bar{\epsilon}} + \frac{1}{\bar{\epsilon}} e^{-\nu_c} \omega^2} \\ &= \epsilon (\bar{\omega}) e^{-\nu_c/2} \omega \quad \text{for } \bar{\epsilon} = 1 \end{aligned} \quad (6.1)$$

also in a curved space-time (3.1), provided that the f_{00} component of the metric tensor is also a constant, i.e.

$$\nu_c' = 0 \Rightarrow e^{\nu_c} = 1 - \frac{\alpha}{s_B} = \text{const.} \quad (6.2)$$

In the case that this condition holds Anderson's analysis³⁵⁾ of the classical phase space (R, R') of the HKG equation can be applied to a certain extent. The main result is that stable (particle-like) solutions can exist if the parameter B_{And} employed already in (2.7) satisfies the condition

$$B_{\text{And}} \equiv \frac{1}{4} (1 - e^{-\nu_c} \omega^2) < \frac{3}{16} \quad (6.3)$$

Then the stable equilibrium points in the phase space of the asymptotic version of (3.15) correspond to the constant solution (6.1) with the negative sign of the square root. This solution which the geon may adopt in its interior gives rise to a constant scalar density

$$\bar{s}_{00} = \frac{8}{9 \beta^2 N^2} \frac{l^{*2}}{l^2} \left[4 \omega^2 e^{-\nu_c} + 2 - \epsilon (R_c^\omega)^2 \right] (R_c^\omega)^2 \quad (6.4)$$

as well as to a constant "pressure" term

$$\bar{p}_0 = \frac{g}{9\beta^2 N^2} \frac{\ell^{*2}}{\ell^2} [2e^{-\gamma_c} \omega^2 - 2 + \epsilon (R_c^\omega)^2] (R_c^\omega)^2 \quad (6.5)$$

If we absorb (6.4) into an effective "cosmological"

$$\Lambda_{\text{eff}} = \Lambda_{\text{bag}} + \bar{g}_{00} \quad (6.6)$$

solutions of (4.14) which are regular at the origin read

$$e^{-\lambda} = 1 - \frac{1}{3} g^2 \Lambda_{\text{eff}} \quad (6.7)$$

From $e^{\gamma_c} = \text{const}$, i.e. Eq.(6.2), we can infer that the constant radial solutions (6.1) exist only in (a portion of) an Einstein "microcosmos" (compare with Tolman²³), §135 and §139). (Note that (2.6) admits also non-trivial radial solutions⁴⁷) in an Einstein Universe. These exact solutions however are not geon-type solutions, i.e. they do not satisfy the Einstein equations (1.4) at the same time.)

The remaining radial Einstein equation (4.13) yields the "equation of state"

$$\bar{g}_{00} = 2 \Lambda_{\text{bag}} - 3 \bar{p}_0 \geq 0 \quad (6.8)$$

for the "density" \bar{g}_{00} in terms of the "hydrostatic pressure" \bar{p}_0 . After insertion of (6.4) and (6.5) into (6.8) we obtain

$$5 \omega^2 e^{-\gamma_c} - 2 + \epsilon (R_c^\omega)^2 = \frac{3 \beta^2 N^2 \ell^2}{8 \ell^{*2}} \Lambda_{\text{bag}} \quad (6.9)$$

which, in view of (6.1), determines $\gamma_c = \gamma_c(\omega)$ as a function of ω and Λ .

Our geon construction may now follow closely those by which Schwarzschild (see Ref.23, §96) obtained the exterior and interior solutions for a spherical star consisting of an incompressible perfect fluid of constant property density \bar{g}_{00} . To this end we may use (6.1) together with the condition

(6.2) and the resulting metric function (6.7) as solutions for the interior $0 \leq \varrho \leq \varrho_B$ of a ball. Then the curvature potential (3.13) associated with this metrical background is also a constant, i.e. more precisely

$$V_{\text{eff}}^0 = -\frac{1}{3} e^{\gamma_c} \Lambda_{\text{eff}} \quad (6.10)$$

In order to interpret the interior solution (6.1) as a kind of "bound state" within a negative potential produced by a gluonic "bag" of tensor forces we have to require $\Lambda_{\text{eff}} > 0$.

In view of (6.6) and (6.8) this condition can be satisfied for $\Lambda_{\text{bag}} \geq \frac{3}{2} \bar{p}_0 > 0$ only. Such a non-zero "bag constant" Λ_{bag} is necessary for the interior of the geon in order to compensate for the "vacuum" pressure (6.5) of the "quark-type" scalar fields. A similar mechanism has been proposed in the phenomenological MIT "bag" model of hadrons³³. (If Λ_{bag} would be zero, the condition (6.8) is the same as that for a random distribution of electromagnetic radiation (Tolman²³), p.217) except for the sign.)

Outside the constant bag-like core of radius ϱ_B we may simply continue with $R = 0$ (if in this idealized construction we are contented with solutions which are only piece-wise differentiable and continuous) and obtain for $\Lambda_{\text{ext}} = 0$ a Schwarzschild solution (4.17) for

$$g \geq \varrho_B \equiv \left(\frac{3\alpha}{\Lambda_{\text{eff}}} \right)^{1/3} > \alpha \quad (6.11)$$

This crude geon construction allows us to evaluate the total charge (5.4) in closed form:

Insertion of (6.1), (6.2) and (6.7) into (5.5) yields

$$\frac{Q}{e} = \frac{32}{3} \frac{\omega}{\beta N} \frac{\ell^{*2}}{\ell^2} e^{-\gamma_c/2} (R_c^\omega)^2 \int_0^{\varrho_B} d\varrho \varrho^2 \left(1 - \frac{1}{3} g^2 \Lambda_{\text{eff}} \right)^{-1/2} \quad (6.12)$$

The remaining integration can be performed with the aid of an integral representation (see Eq.(30) of Ref.47) of the hypergeometric function. The charge quantization (5.3) then leads to the normalization condition

$$k = \frac{32}{9} \frac{\omega}{\beta N} \frac{\ell^{*2}}{\ell^2} (R_c^\omega)^2 e^{-\gamma_c/2} s_B^3 \times {}_2F_1\left(\frac{1}{2}, \frac{3}{2}, \frac{5}{2}, \frac{1}{3} s_B^2 \Lambda_{\text{eff}}\right). \quad (6.13)$$

For $\Lambda_{\text{ext}} = 0$ and assuming here also $\alpha = 3\Lambda_{\text{eff}}$ the above result can be used to determine the scalar density (6.4) respecting the condition (6.8) as

$$\bar{s}_{00} = \frac{16}{3} \frac{\beta^2 N^2}{k^2} \frac{e^{\gamma_c}}{\omega^2} \quad (6.14)$$

In a similar way we may calculate the already normalized expression (5.12) for the gravitational mass αM^* .

Let us consider the case $\bar{E} = 1$. The insertion of (6.1) and furthermore (6.9) into (5.12) yields

$$\alpha = \frac{k}{\beta N} \frac{5\omega^2 \bar{\sigma} \epsilon e^{\gamma_c/2} - e^{\gamma_c}}{6\omega} = k \frac{\beta N}{16} \frac{\ell^2}{\ell^{*2}} \frac{\Lambda_{\text{bag}}}{\omega} \quad (6.15)$$

a result which could also be inferred from the comparison of condition (6.8) with the equivalent expression (5.9) of the Tolman energy.

Since for $\varrho > \varrho_B$ the space-time geometry is determined by the Schwarzschild solution (4.17) with $\Lambda_{\text{ext}} = 0$ and α given by (6.15), an "observer" placed outside the core will regard this gravitational bound state of scalar fields as an object having the mass αM^* . For $\Lambda_{\text{bag}} = 0$ the hadronic environment, i.e. the strong curvature generated by the "tensor gluons" $f_{\mu\nu}$ inside the "constant core" gives rise to such a strong "Archimedes effect" (7) on the scalar constituent fields, that their binding energy (5.14) becomes equal to the rest mass $\omega \mu c^2$ of a self-interacting "quark".

This can be summarized in a Wheeler-type phrase: A constant "bag-like" geon may have "mass without mass" (Ref. 37, p.25).

VII. LOCALIZED GEON SOLUTIONS FROM NUMERICAL INTEGRATION

According to our introductory remarks we will reserve the term "geon-type solution" (compare Sec. VIII for other notions) for configurations resulting from a self-consistent coupling of fields to gravity in which both the "matter" waves and ^{the} metric tensor are (non-singular) and sufficiently localized. A precise criterion for localization depends crucially on the circumstance of whether or not a cosmological constant Λ is included. For the present we put $\Lambda = 0$ and may then require for localized, spherically symmetric scalar geons the following set of

a) Asymptotic solutions at spatial infinity

We proceed similarly as in Sec. III.c of paper I ³⁰⁾ and consider radial solutions which behave asymptotically as

$$R_c^\omega(\varrho) \approx C_\omega \varrho^6 \exp\left[-\frac{1}{\beta N} \sqrt{1-\omega^2} \varrho\right] \quad (7.1)$$

If $|\omega| < 1$, such boundary conditions for the numerical integration would necessary lead to exponentially decreasing Yukawa-type solutions (see also Ref. 48) irrespective of the parameter ϱ . Since the scalar waves would already be sufficiently localized, the equations (4.13) and (4.14) pass into the Einstein vacuum equations. Given the canonical form (3.1) these yield uniquely the Schwarzschild solutions (4.9) with $\Lambda = 0$.

Therefore

$$e^\nu \approx e^{-\lambda} = 1 - \frac{\alpha}{\varrho} + O(\varrho^2) \quad (7.2)$$

will hold. The asymptotic forms (7.1) and (7.2) are then inserted into (3.15) in order to determine ϱ on ^{the} grounds of self-consistency. By equating the coefficients of the $1/\varrho$ -expansion we obtain

$$\bar{\sigma} = -1 \bar{\sigma} \frac{\alpha(1-2\omega^2)}{2\beta N \sqrt{1-\omega^2}} \quad (7.2)$$

This result being independent of the quantum number l of angular momentum agrees for the plus sign with that obtained by Kaup ³¹⁾.

Let us turn to the

b) Asymptotic solutions at the origin

Guided by the "constant core" case analysed in the preceding section we found it reasonable to assume

$$y' \simeq 0 \Rightarrow e^y \simeq e^{y_c} = \text{const.} \quad (7.4)$$

in the vicinity of the origin.

0_I) Suppose we find

$$R' \simeq \bar{c}_0 \quad (7.5)$$

Then from (4.14) and (4.13) it follows that the radial metric function behaves as

$$e^{-\lambda} \simeq 1 - \frac{1}{3} s^2 \mathcal{L}_{\text{eff}} \quad (7.6)$$

at the origin. This corresponds to the exact result (5.7). Then the radial equation (3.15) takes the asymptotic form

$$\begin{aligned} & \left[\partial_s^2 + \frac{2}{s} \partial_s - \frac{\mathcal{L}(\mathcal{L}+1)}{s^2} \right] R = \\ & = \frac{1}{\beta^2 N^2} (\bar{\epsilon} R^4 - 2\epsilon R^2 + 1 - e^{-\frac{1}{2}\omega^2}) R \end{aligned} \quad (7.7)$$

(compare with Eq.(3.11) of I). A familiar argument expanded in I yields

$$R_l^\omega(s) \simeq c_0 s^l \quad (7.8)$$

as asymptotic solutions regular at the origin. The system of approximate solutions (7.4), (7.6) and (7.8) turns out to be consistent.

0_{II}) Another set of asymptotic solutions can be obtained by proposing instead of (7.5) the trial function

$$R_0^\omega(s) \simeq \sqrt{\frac{3}{8}} \frac{l}{l^*} \ln s \quad (7.9)$$

for $l = 0$.

Assuming that $e^\lambda \simeq 0$ for $s \rightarrow 0$ such that

$$\bar{s}_{00} e^\lambda \simeq \frac{1}{s^2} \quad (7.10)$$

we obtain from (4.14) the result

$$e^\lambda \simeq 4 A_0^2 s^2 \quad (7.11)$$

This together with (7.4) satisfies also (4.13). Furthermore, the insertion of (7.11) into the radial equation (3.15) yields

$$\frac{R''}{R'} \simeq -\frac{1}{s} \quad (7.12)$$

Its integration results in (7.9), the integration constant already being determined by (7.10). The sets (7.4), (7.9) and (7.10) of asymptotic solutions have earlier been discussed by Feinblum and McKinley⁴⁶⁾.

In spite of the fact that in the latter case the radial part of the scalar waves is logarithmically divergent at origin, we should not disregard these solutions. For a more precise reasoning we have to also take the strongly deformed space-time manifold at the origin into account. This effect becomes more transparent if we consider the function $F_0^\omega(s^*)$ defined via (3.8) in terms of the "tortoise" co-ordinate (3.9). In view of (7.4) and (7.12) the latter acquires the asymptotic behaviour

$$s^* \simeq \frac{1}{A_0} s^2 \quad (7.13)$$

near the origin. By applying l'Hospital's rule we find that

$$\begin{aligned} F_0^\omega(s^*) & \simeq \sqrt{\frac{3}{8}} \frac{l}{l^*} \sqrt{A_0 s^*} \ln \sqrt{A_0 s^*} \\ & \rightarrow -\sqrt{\frac{3}{2}} \frac{l}{l^*} s \rightarrow 0 \end{aligned} \quad (7.14)$$

tends to zero for $\xi \rightarrow 0$. Therefore the charge integral (5.5) should be bounded even at the origin. Since the subsidiary conditions of bounded square-integrability and fast decrease at spatial infinity turn out to be fulfilled, solutions with the asymptotics O_{II} in curved space-time can also be regarded as "eigenfunctions", according to the criteria of quantum mechanics (see §16 of Ref.38). With respect to the formal Schrödinger-type equation (3.12) the dynamics corresponds to the motion of a "particle" in a centrally symmetric field characterized by a centripetal potential

$$V_{\text{eff}}(\xi^*) \simeq -\frac{e^{\chi}}{4\xi^{*2}} \quad (7.15)$$

near the origin (compare with Ref.38, p.109).

With this information at hand we have performed the numerical calculations on a DEC-PDP-10-computer using single precision NAG and IMSL Library subroutines. The evaluation of the functions $R_c^{\alpha}(\xi)$, $e^{\chi(\xi)}$ and $e^{\lambda(\xi)}$ has been done in double precision mode. For all calculations the free parameters of the model have been fixed according to:

$$\Lambda = 0, \quad \bar{\epsilon} = \epsilon = 1, \quad n = 3, \quad k = 1, \quad L = 0, \quad L^*/L = 1, \quad \beta = 0.2$$

Then for each given ω and n_r the system of ordinary differential equations (3.15), (4.13) and (4.14) has been numerically solved by Runge-Kutta formulas of order 5 and 6 as developed by J.H. Verner and coded by Hull and co-workers⁴⁹⁾ in the IMSL subroutine DVERK. The global error of the solutions has been estimated to be less than 1.10^{-4} . Using the asymptotic conditions (7.1) and (7.2) as starting values the integration has been performed going from $\xi_{\infty} = 30$ backwards to zero. Self-consistent solutions are constrained by two additional conditions. First, they have to fulfill the charge normalization (5.5) and second, they have to reproduce the parameters α chosen for the initial conditions consistent with the Tolman integral (5.12) for α . This has been achieved by an iterative least squares fit using the NAG subroutine E04FAF which is based on a method due to Peckham⁵⁰⁾. Thus the parameters α and C_{∞} have been determined by minimizing the sum of squares

$$\sum_j = \left(\frac{k - Q_j}{k}\right)^2 + \left(\frac{\alpha_{j-1} - \alpha_j}{\alpha_{j-1}}\right)^2 \quad (7.16)$$

where j denotes the j^{th} iteration step, α_{j-1} is the result of the $(j-1)^{\text{th}}$ step which fixed the initial conditions (7.1) and (7.2) and Q_j, α_j are calculated from (5.5) and (5.12), respectively.

Using appropriate starting values for C_{∞} and α , a convergence of (7.16) better than 1.10^{-8} has been obtained by the method resulting in a relative error in α and Q of less than 1.10^{-4} . The numerical integration of Q, α and E_{reg} has been performed by using the NAG Library procedure D01GAF which estimates the value of a definite integral (when the functional is specified numerically) using the method described by Gill and Miller⁵¹⁾. The maximal relative error should in no case be larger than 1.10^{-6} .

As can be deduced from the asymptotic solutions (7.10) and (7.12) of the second set O_{II} , the energy expression (5.14) contains a term $\ln \xi_0$ which diverges for $\xi_0 \rightarrow 0$. Therefore in Fig.4 we have computed only the finite part of E , i.e. E_{reg} , corresponding to the "cut-off" parameter $\xi_0 = 0.001$.

So far our method of integrating backward has produced solutions belonging solely to the set O_{II} of asymptotic solutions at the origin. In this case we found solutions with and without nodes. The number of nodes of the radial part $R_c^{\alpha}(\xi)$ of the wave function for finite values of ξ (excluding the point $\xi = 0$) may be used to define as a radial quantum number n_r as in the non-relativistic Schrödinger theory (Ref.38, p.109). From the theory of the hydrogen atom we suspect the relation

$$n_r = n - L - 1 \quad (7.17)$$

to hold (Ref.38, p.123) where n would denote the "principal quantum number of the geon"

Figs.1 and 2 reveal that our numerical results interpolate rather well between the asymptotic solutions at infinity and at the origin (set O_{II}). In the case without nodes (Fig.1a) the radial scalar function $R_0^{\alpha}(\xi)$ joins smoothly the asymptotic solution (7.9) with the localized solution (7.1). Both metric functions show a Schwarzschild-type behaviour for large ξ . For small ξ , e^{χ} becomes constant (Figs.1b, 2b) similar as in the constant core case, whereas e^{λ} tends to zero in accordance with (7.11). The latter function develops inbetween a noticeable peak (Figs.1c, 2c) which corresponds to the confining barrier in the effective curvature potential (3.13) Figs.1e, 2e).

An interesting phenomenon can be observed on the level of the Schrödinger-type wave function $F_0^{\omega}(\xi^*)$ being defined with respect to the "pseudo-flat" space-time (3.10). $F_0^{\omega}(\xi^*)$ is concentrated (see Figs.1d, 2d)

within the negative well of $V_{\text{eff}}^0(\omega)$ with its maximum close to the zero of the potential. For smaller values of ω this maximum is shifted by the barrier of the curvature potential closer to the origin. This seems to indicate a self-generating effect of the geometro-dynamical confinement mechanism (being here only partial): This confinement scheme and its proposed ¹³⁾ extension including colour may be compared with, e.g. the MIT "bag" model ³³⁾ (see also Hasenfratz and Kuti ⁵²⁾ for a review). There an ad-hoc introduction of a "vacuum" pressure term Λ_{bag} is needed to compensate for the outside directed pressure of the "quark gas". In contrast to this phenomenological device our approach rather resembles Creutz's ⁵³⁾ reconstruction of a bag model from local non-linear field theory. Similar to his, the "core" of our "bag" is produced by employing the stable (quantum-mechanically metastable solution) of the HKG equation for an extended part of the space. Surrounding this "core" is a transition region, the "skin" of the "bag", consisting of an exponentially decreasing Yukawa-type radial solution for the scalar field and a Coulomb type potential for the "tensor gluons".

The total gravitational mass (5.12) as measured at infinity exhibits a branching for the zero and one node solutions with respect to its ω -dependence (Fig.3). For $n_r = 0$ and low ω we may understand the qualitative behaviour of $\alpha(\omega)$ by comparing it with (see Ref.54)

$$\alpha'(\omega) = \frac{k}{\beta N} (\omega - 2\beta N \omega^3) \quad (7.18)$$

but for higher values of ω Eq.(5.12) tends to

$$\alpha \approx \frac{k}{\beta N} (\omega - \frac{1}{2\omega}) \quad (7.19)$$

The resulting predictions for the zero and the maximum of the Tolman energy, i.e.

$$\omega_0 = \sqrt{\frac{1}{2}} = 0.71 \quad (7.20)$$

and

$$\omega_{\text{max}} = (6\beta N)^{-1/2} = 0.53, \quad (7.21)$$

$$\alpha(\omega_{\text{max}}) = 0.59 \quad (7.22)$$

respectively, agree quite well with our results (Fig.3).

Already for $n_r = 1$ and higher node solutions we found parts of several sub-branches in $\alpha(\omega)$, i.e. the Tolman energy of these geons deviates in a noticeable way (not shown in Fig.3). In a preliminary study we could distinguish the corresponding solutions among others by the number of nodes in R .

Further analysis is in progress in order to understand these highly interesting instances of a possible "fine structure" in the energy levels of the geons. In view of these rich and prospective structures does there exist the speculative alternative to interpret quantum geons ²⁶⁾ as extended particles capable of internal excitations?

VIII. OTHER GRAVITATIONAL SOLITONS

To some extent Wheeler's ²⁴⁾ geon concept has anticipated the, (non-integrable) soliton solutions ⁴⁵⁾ of classical non-linear field theories. As mentioned in the Introduction a geon or gravitational soliton originally was meant to consist of a spherical shell of electromagnetic radiation held together by its own gravitational attraction. In the idealized case of a thin spherical geon the corresponding metric functions have the values $e^{\nu c} = \frac{1}{9}$ well inside and $e^{-\lambda} = 1 - \frac{\alpha}{9}$ well outside the active region. The trapping area for the electromagnetic wave trains has a radius of $r_{\text{active}} = \frac{9}{8} \alpha$. ⁵⁵⁾ This result has been confirmed by applying Ritz variational principles ⁵⁵⁾.

Constructions with toroidal or linear electromagnetic waves have been given by Ernst ⁵⁵⁾ whereas neutrino geons have been analysed by Brill and Wheeler ²⁹⁾.

Brill and Hartle ⁵⁶⁾ could even demonstrate the existence of pure gravitational solitons. By expanding the occurring gravitational waves in terms of tensor spherical harmonics ⁵⁷⁾ it can be shown that the radial function experiences the same effective potential (3.13) except that an additional factor $\frac{3}{2}$ appears in front of the contribution from the background metric.

In a relevant paper the coupling of linear Klein-Gordon fields to gravity has been numerically studied by Kaup ³¹⁾. Moreover, the problem of the stability of the resulting scalar geons with respect to radial perturbations

is treated. It is shown that such objects are resistant to gravitational collapse (related works include Refs. 58, 46 and 48). These considerations are on a semiclassical level. However, using a Hartree-Fock approximation for the second quantized two-body problem it can be shown⁵⁴⁾ that the same coupled Einstein-Klein-Gordon equations apply.

As an important new ingredient, Kodama et al.⁴²⁾ have considered a real scalar field with a ϕ^4 self-interaction as a source for the gravitational field. In this preliminary study the Klein-Gordon operator corresponding to flat space-time is assumed.

A general relativistic Klein-Gordon field with an effective ϕ^3 self-interaction for an interior ball has also been analysed by this group⁵⁹⁾. In order to avoid a singular configuration at origin a repulsive (or "ghost-like") scalar field has been chosen as a source of Einstein's equations. In a further step Kodama⁶⁰⁾ constructed a spherically symmetric kink-type solution for a repulsive scalar field with ϕ^4 self-coupling (compare also with Ellis⁶¹⁾). As is common for kinks, the radial function at spatial infinity is chosen to be a constant characterizing this non-linear model. If we want to transfer the method to our case, we may use instead of (2.3) the symmetric self-interaction

$$\begin{aligned} \tilde{U}(|\phi|^2) &\equiv \frac{3}{4} \ell^4 \left(|\phi|^2 - \frac{16\epsilon}{3\ell^2} \frac{\mu c}{\hbar} \right)^3 \\ &= U(|\phi|^2) - \frac{16\epsilon}{9\ell^2} \left(\frac{\mu c}{\hbar} \right)^3 \quad \text{for } \bar{\epsilon} = 1 \end{aligned} \quad (8.1)$$

The additional constant in (8.1) necessarily eliminates the gravitational source which otherwise would occur for the constant solution

$$\varphi_c^{(N)} = \frac{4}{\ell} \sqrt{\frac{\epsilon \mu c}{3 \hbar}} e^{i\delta}, \quad \varphi^{(q)} = 0 \quad \text{if } q \neq N \quad (8.2)$$

characterizing the kink solution asymptotically. In flat Minkowski space it is a conjecture that (8.2) constitutes a first approximation to the vacuum expectation value $\langle 0 | \Phi | 0 \rangle$ of the corresponding quantum field.

For the general relativistic kink of Kodama⁶⁰⁾ the radial solution becomes zero at a certain radius r_0 at which the background geometry develops a Schwarzschild-type horizon. (Geon-type solutions exhibiting an event horizon may be termed "black solitons"⁶²⁾.) The boundary condition at r_0 ,

however, allows an extension of these solutions into a 3-manifold consisting of two asymptotically Euclidean spaces connected by an Einstein-Rosen bridge²⁵⁾. Arguments are given⁶³⁾ that this extended, non-singular configuration is stable with respect to radial oscillations.

It should be noted that such solutions cannot be constructed for the "wormhole" topology $R \times S^1 \times S^2$ which would be obtainable by identifying the asymptotically flat regions. The reason simply being that the radial functions of the kink has an opposite sign in the other sheet of the Universe. Since the quantum-mechanical probability density $|\varphi(x)|^2$ is single valued and completely regular also for the wormhole topology, such scalar kinks provide interesting objects for further studies.

Although we have no intention to give a complete review, we would like to mention that other studies on geons involve massless scalar fields⁶⁴⁾⁻⁶⁷⁾ coupled Einstein-Maxwell-Klein-Gordon systems^{58),68)-70)} or even combined Dirac-Einstein-Maxwell field equations⁷¹⁾.

As a final observation we remark that, according to a result of Brill⁷²⁾ a massless scalar field can be geometrized in the sense of the "already unified field theory" or "geometrodynamics" of Rainich, Misner and Wheeler³⁷⁾. Loosely speaking, this means that the scalar field can be completely read off from the "footprints" it leaves on the geometry.

ACKNOWLEDGMENTS

We would like to thank Professor R. Ruffini and Professor Abdus Salam for useful hints. One of us (E.W.M.) would like to express his sincere gratitude to Professors F.W. Kehl, Abdus Salam and J.A. Wheeler for encouragement and support, and would also like to thank Professor Abdus Salam, the International Atomic Energy Agency and UNESCO for hospitality at the International Centre for Theoretical Physics, Trieste. This work was supported by the Deutsche Forschungsgemeinschaft. The computations were performed at the Rechenzentrum of the Christian-Albrechts-Universität, Kiel.

REFERENCES

- 1) J.J.J. Kokkedee, The Quark Model (Benjamin, New York 1969).
- 2) R.N. Boyd, D. Elmore, A.C. Melissimos and E. Sugarbaker, Phys. Rev. Letters 40, 216 (1978).
- 3) O.W. Greenberg and C.A. Nelson, Phys. Rev. 32C, 69 (1977).
- 4) D. Friedberg, T.D. Lee and A. Sirlin, Phys. Rev. D13, 2739 (1976); Nucl. Phys. B115, 1; 32 (1976).
- 5) W. Marciano and H. Pagels, Phys. Rep. 36C, 137 (1978).
- 6) A. Salam and J. Strathdee, Phys. Letters 67B, 429 (1977).
- 7) A. Salam and J. Strathdee, Phys. Rev. D18, 4596 (1978).
- 8) C.N. Yang and R.L. Mills, Phys. Rev. 96, 191 (1954).
- 9) S. Coleman and L. Smarr, Commun. Math. Phys. 56, 1 (1977).
- 10) D. Robson, Nucl. Phys. B130, 328 (1977).
- 11) E.W. Mielke, Phys. Rev. Letters 39, 530 (1977); 39, 851 (E) (1977).
- 12) E.W. Mielke, "Gauge-theoretical foundation of colour geometrodynamics" (to be published in the Proceedings of the 1978 Clausthal meeting, Ed. H.D. Doebner).
- 13) E.W. Mielke, ICTP, Trieste, preprint IC/80/54 (to appear in Int. J. Theoret. Phys.);
- 14) C.J. Isham, A. Salam and J. Strathdee, Phys. Rev. D3, 867 (1971).
- 15) C.J. Isham, A. Salam and J. Strathdee, Phys. Rev. D8, 2600 (1973).
- 16) C.J. Isham, A. Salam and J. Strathdee, Phys. Rev. D9, 1702 (1974).
- 17) F.E. Hehl, P. von der Heyde, G.D. Kerlick and J.M. Nester, Rev. Mod. Phys. 48, 393 (1976).
- 18) H. Weyl, Proc. Nat. Acad. Sci. (USA) 15, 323 (1929).
- 19) H. Weyl, Phys. Rev. 77, 699 (1950).
- 20) W. Heisenberg, Introduction to the Unified Field Theory of Elementary Particles (Wiley, London 1966).
- 21) E. Schrödinger, Sitzungsber Preuss. Akad. Wiss. Phys.-Math. Kl. XI, 105 (1932).
- 22) D. Ivanenko, Sov. Phys. 13, 141 (1938); Suppl. Nuovo Cimento 6, 349 (1957).
- 23) R.C. Tolman, Relativity, Thermodynamics and Cosmology (Clarendon Press, Oxford 1934).
- 24) J.A. Wheeler, Phys. Rev. 97, 511 (1955).
- 25) A. Einstein and N. Rosen, Phys. Rev. 48, 73 (1935).
- 26) J.A. Wheeler, Rev. Mod. Phys. 33, 63 (1961).
- 27) R.J. Finkelstein, Phys. Rev. 75, 1079 (1949).
- 28) R. Finkelstein, R. Lelevier and M. Ruderman, Phys. Rev. 83, 326 (1951).
- 29) D.R. Brill and J.A. Wheeler, Rev. Mod. Phys. 29, 465 (1957), (E) 33, 623 (1961).
- 30) W. Deppert and E.W. Mielke, Phys. Rev. D20, 1303 (1979).
- 31) D.J. Kaup, Phys. Rev. 172, 1331 (1968).
- 32) R.C. Tolman, Phys. Rev. 35, 875 (1930).
- 33) A. Chodos, R.L. Jaffe, K. Johnson, C.B. Thorne and V.F. Weisskopf, Phys. Rev. D9, 3471 (1974).
- 34) P. Boyanovsky and L. Masperi, Phys. Rev. D21, 1550 (1980).
- 35) D.L.T. Anderson, J. Math. Phys. 12, 945 (1971).
- 36) C.W. Misner, K.S. Thorne and J.A. Wheeler, Gravitation (W.H. Freeman and Co., San Francisco 1973), (quoted as MTW).
- 37) J.W. Wheeler, Geometrodynamics (Academic Press, New York 1962) (contains reprints of Refs. 24 and 41).
- 38) L.D. Landau and E.M. Lifschitz, Quantum Mechanics - Non-Relativistic Theory (Pergamon, London 1967).
- 39) E.W. Mielke, Gen. Rel. Grav. 8, 321 (1977).
- 40) H. Rund and D. Lovelock, Jber. Deutsch. Math.-Verein 74, 1 (1972).
- 41) E.A. Power and J.A. Wheeler, Rev. Mod. Phys. 29, 480 (1957).
- 42) T. Kodama, K.C. Chung and A.F. da F. Teixeira, Nuovo Cimento 46, 206 (1978).
- 43) R. Jackiw, Rev. Mod. Phys. 49, 681 (1977).
- 44) S.A. Fulling, Phys. Rev. D7, 2850 (1973).
- 45) V.G. Makhankov, Phys. Rep. 35C, 1 (1978).
- 46) D.A. Feinblum and W.A. McKinley, Phys. Rev. 168, 1445 (1968).
- 47) E.W. Mielke, J. Math. Phys. 21, 543 (1980).
- 48) A.F. da F. Teixeira, I. Wolk and M.M. Som, Phys. Rev. D12, 319 (1975).

- 49) T.E. Hull, W.H. Enright and K.R. Jackson, TR No.100, Dept. of Computer Science, University of Toronto (1976).
- 50) G. Peckham, Computer J. 13, 418 (1970).
- 51) P.E. Gill and G.F. Miller, Computer J. 15, 80 (1972).
- 52) P. Hasenfratz and J. Kuti, Phys. Rep. 40C, 75 (1978).
- 53) M. Creutz, Phys. Rev. D10, 1749 (1974).
- 54) R. Ruffini and S. Bonazzola, Phys. Rev. 187, 1767 (1969).
- 55) F.J. Ernst, Jr., Phys. Rev. 105, 1662; 1665 (1957).
- 56) D.R. Brill and J.B. Hartle, Phys. Rev. 135, B271 (1964).
- 57) T. Regge and J.A. Wheeler, Phys. Rev. 108, 1063 (1957).
- 58) A. Das, J. Math. Phys. 4, 45 (1963).
- 59) K.C. Chung, T. Kodama and A.F. da F. Teixeira, Phys. Rev. D16, 2412 (1977).
- 60) T. Kodama, Phys. Rev. D18, 3529 (1978).
- 61) H.G. Ellis, GRG 10, 105 (1979).
- 62) A. Salam and J. Strathdee, Phys. Letters 61B, 375 (1976); 66B, 143 (1977).
- 63) T. Kodama, L.C.S. de Oliveira and F.C. Santos, Phys. Rev. D19, 3576 (1979).
- 64) S. Deser and J. Higbie, Ann. Phys. (N.Y.) 58, 56 (1970).
- 65) J.D. Bekenstein, Ann. Phys. (N.Y.) 82, 535 (1974).
- 66) M. Gürses, Phys. Rev. D15, 2731 (1977).
- 67) M. Lunetta, I. Wolk and A.F. da F. Teixeira, Phys. Rev. D21, 3281 (1980).
- 68) K.A. Bronnikov, V.V. Melnikov, G.N. Shikina and K.P. Staniukovich, Ann. Phys. (N.Y.) 118, 84 (1979).
- 69) A.F. da F. Teixeira, I. Wolk and M.M. Som, J. Phys. A9, 53 (1976).
- 70) A. Banerjee and S.B. Dutta Choudhury, Phys. Rev. D15, 3062 (1977).
- 71) M.J. Hamilton and A. Das, J. Math. Phys. 18, 2026 (1977).
- 72) D. Brill, Nuovo Cimento Suppl. 2, 1 (1964).

FIGURE CAPTIONS

- Fig.1 Scalar geon without node. The results of the numerical integration are shown for the case $\ell^*/\ell = 1$, $\beta = 0.2$, $\Lambda = 0$, $\bar{\epsilon} = \epsilon = 1$, $n = 3$, $k = 1$, $\ell = 0$. The solutions which depend on ω and ξ or ξ^* , respectively, are presented as relief.
- Radial solutions $R_0^{\omega}(\xi)$.
 - Time-like metric function $e^{\nu(\xi)}$.
 - Space-like metric function $e^{\lambda(\xi)}$.
 - Schrödinger-type wave function $F_0^{\omega}(\xi^*)$ given in terms of the "tortoise" co-ordinate ξ^* .
 - Effective curvature potential $V_{\text{eff}}^0(\xi^*)$ exhibiting a deep well together with a confining barrier.
- (In Figs.1a and 1d only a few solutions are shown in order to avoid a too strong screening in the 3D plot which would otherwise occur. In Figs.1d and 1e the curves are plotted up to ξ^* -values corresponding to $\xi = 5$.)
- Fig.2 Scalar geon with one node. Same case and presentation as in Fig.1, except for a broader ω range.
- Radial solutions $R_0^{\omega}(\xi)$ exhibiting one node.
 - Time-like metric function $e^{\nu(\xi)}$.
 - Space-like metric function $e^{\lambda(\xi)}$.
 - Schrödinger-type wave function $F_0^{\omega}(\xi^*)$ having also one node outside the origin (see the magnification (2x in F and 50x in ξ^*) of part of the relief).
 - Effective curvature potential $V_{\text{eff}}^0(\xi^*)$ with a deep well in a confining barrier.
- (Again in Figs.2d and 2e the curves are plotted up to ξ^* -values corresponding to $\xi = 5$.)
- Fig.3 Tolman energy or Schwarzschild mass αM^* as a function of ω for "quantized" scalar geons with "principal quantum number" $n = 1, 2$.
- Fig.4 "Regularized" field energy of the scalar waves within scalar geons as a function of ω , corresponding to a "cut-off" length $\xi_0 = 0.001$.

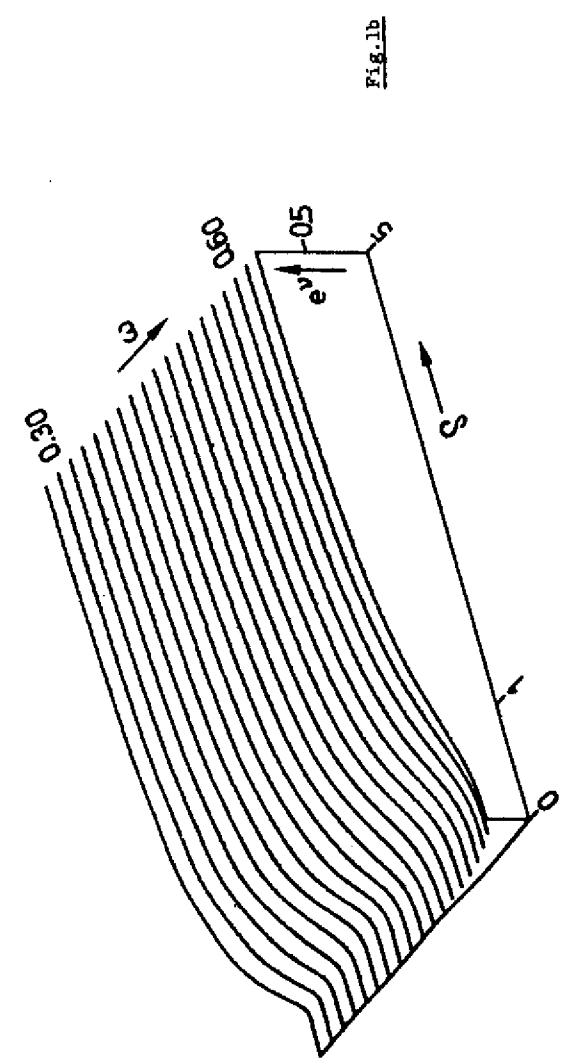
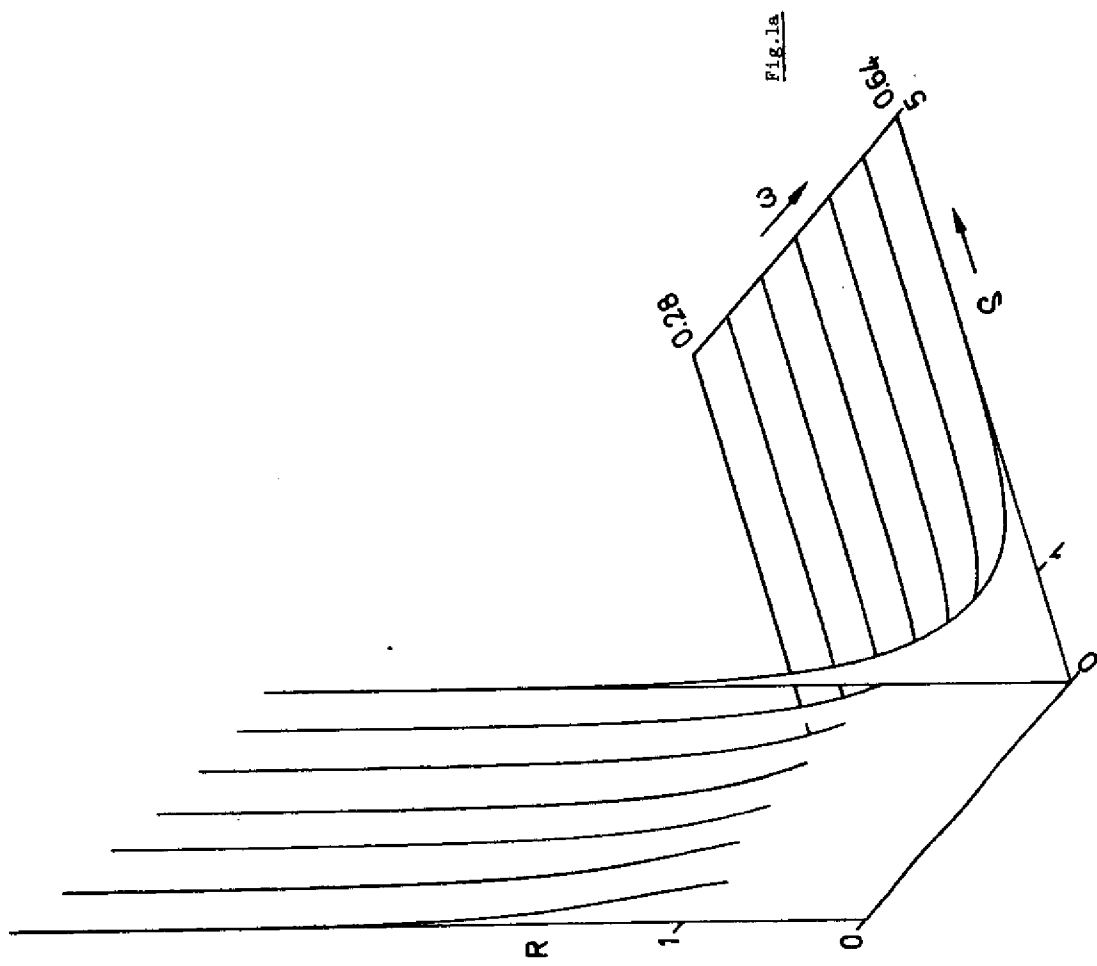

Fig. 1c

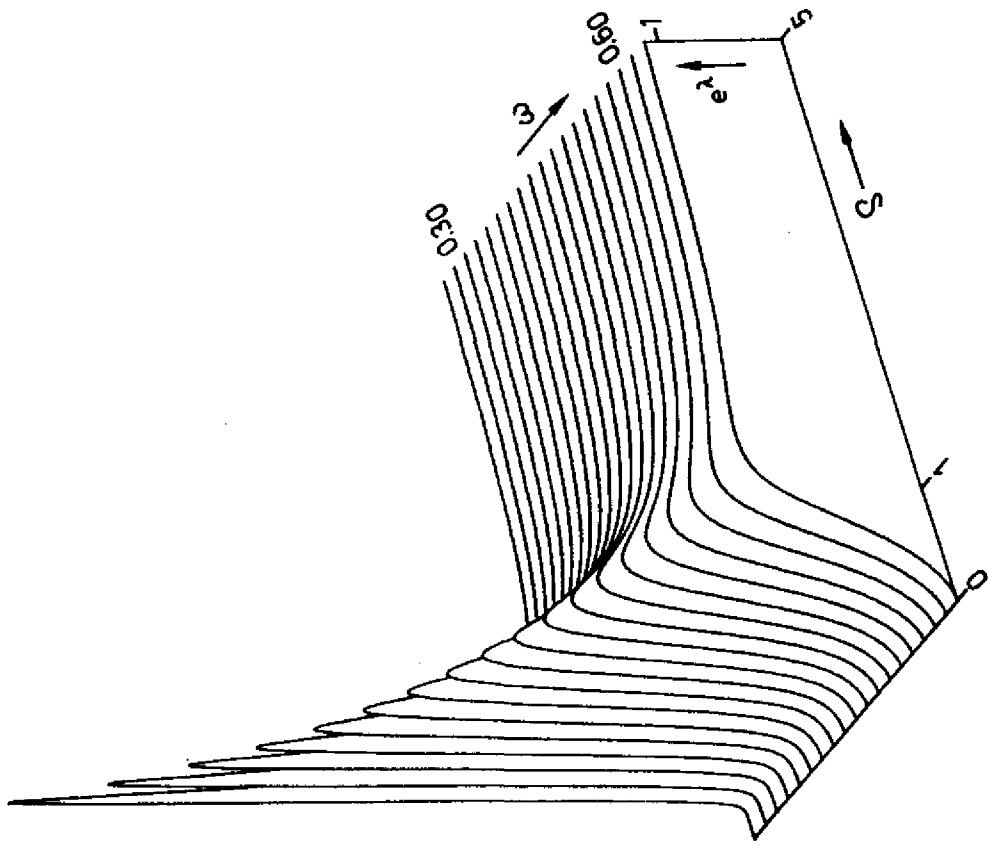
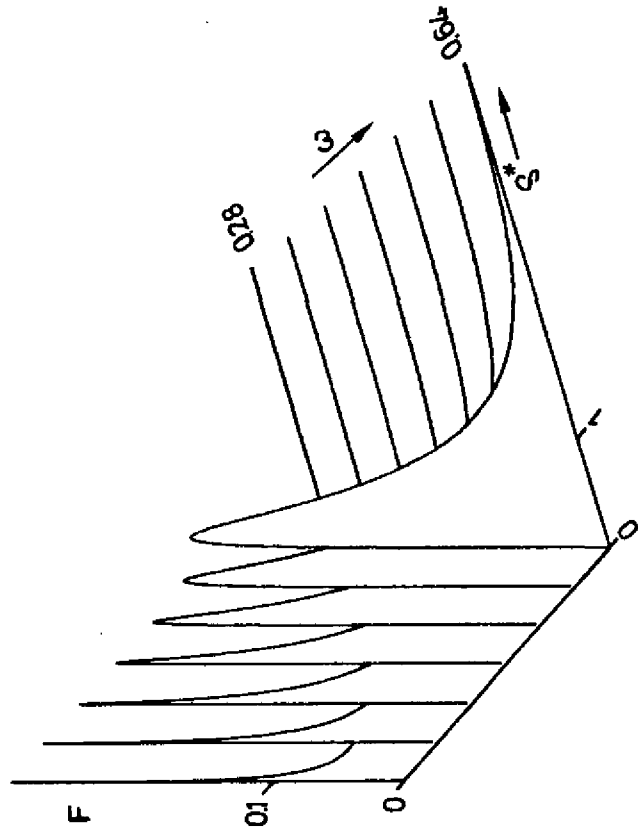

Fig. 1d



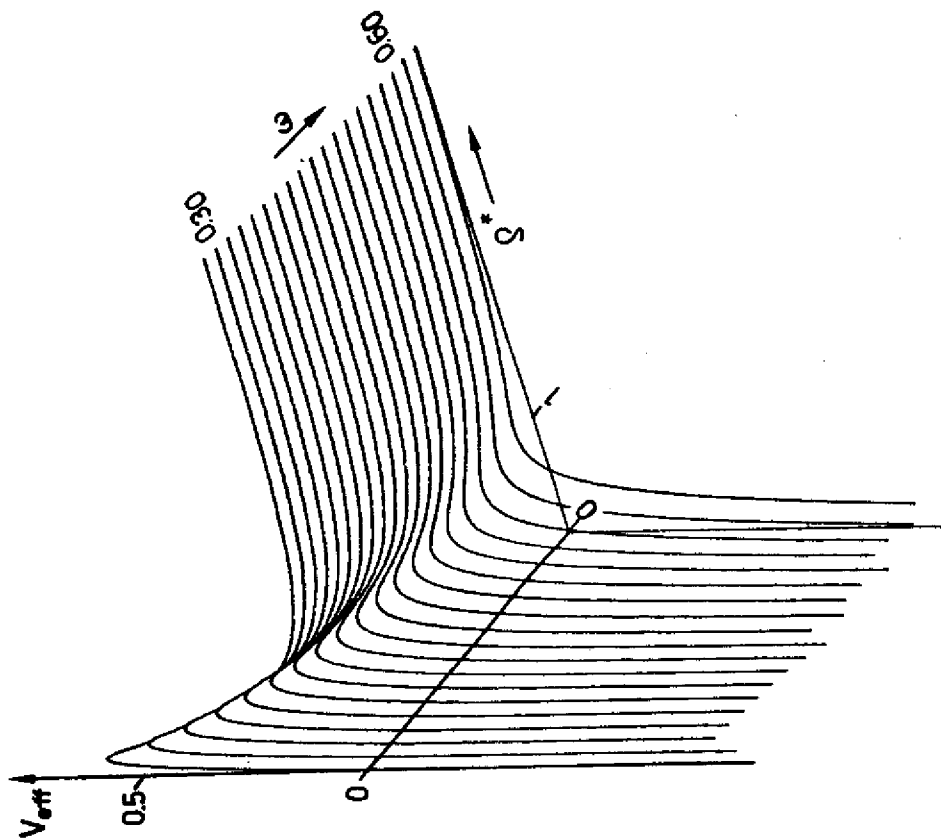

Fig. 1e

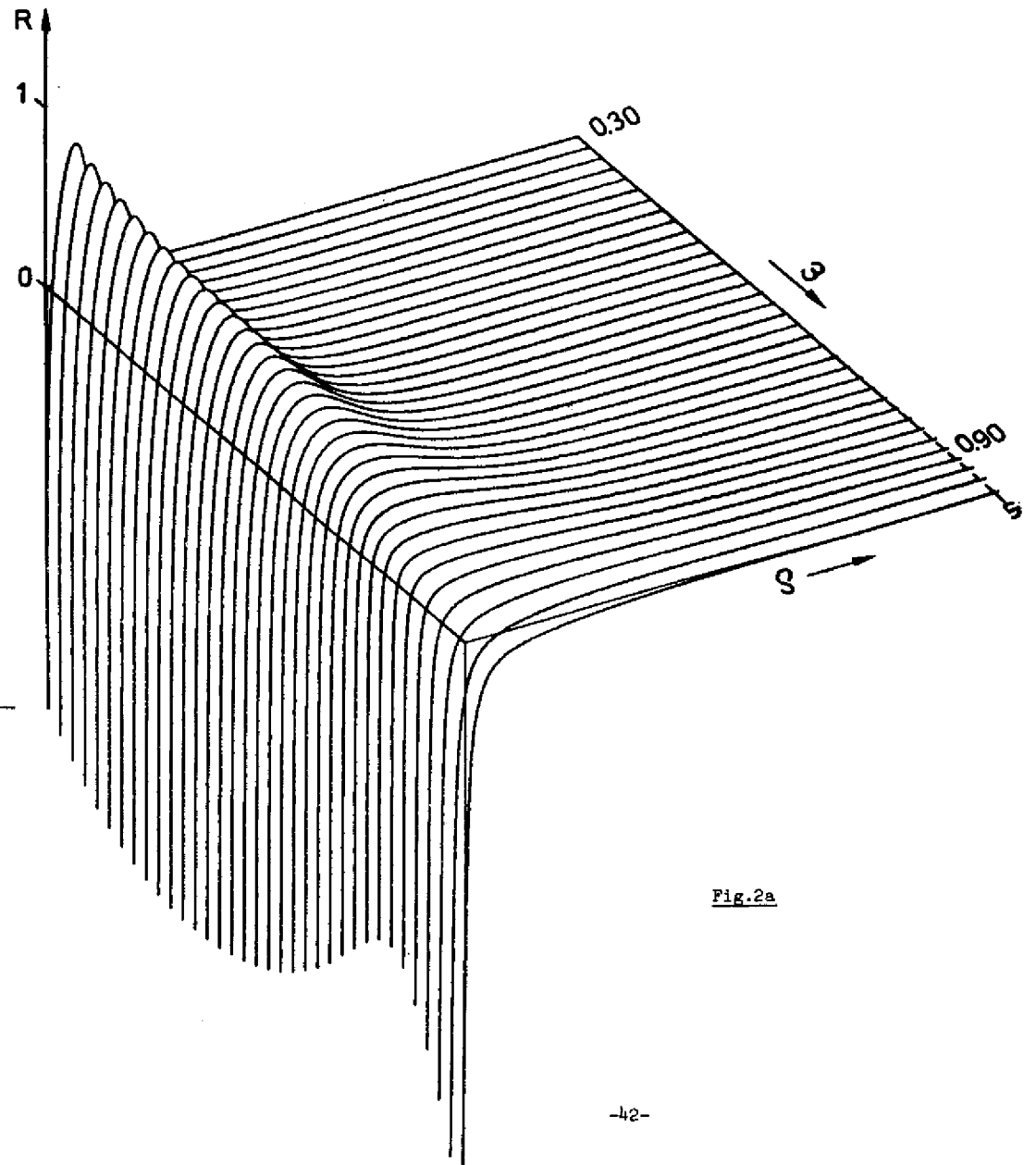
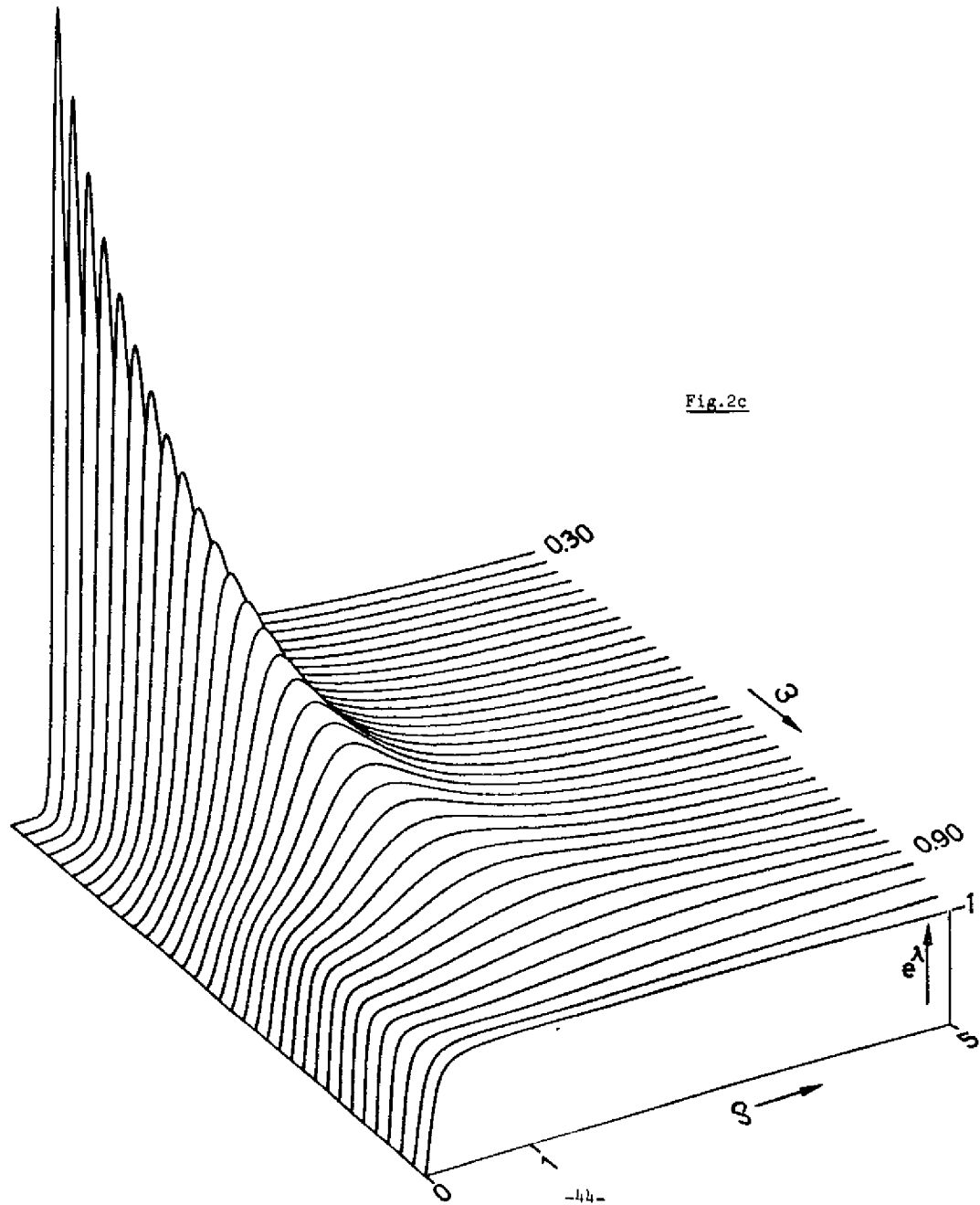
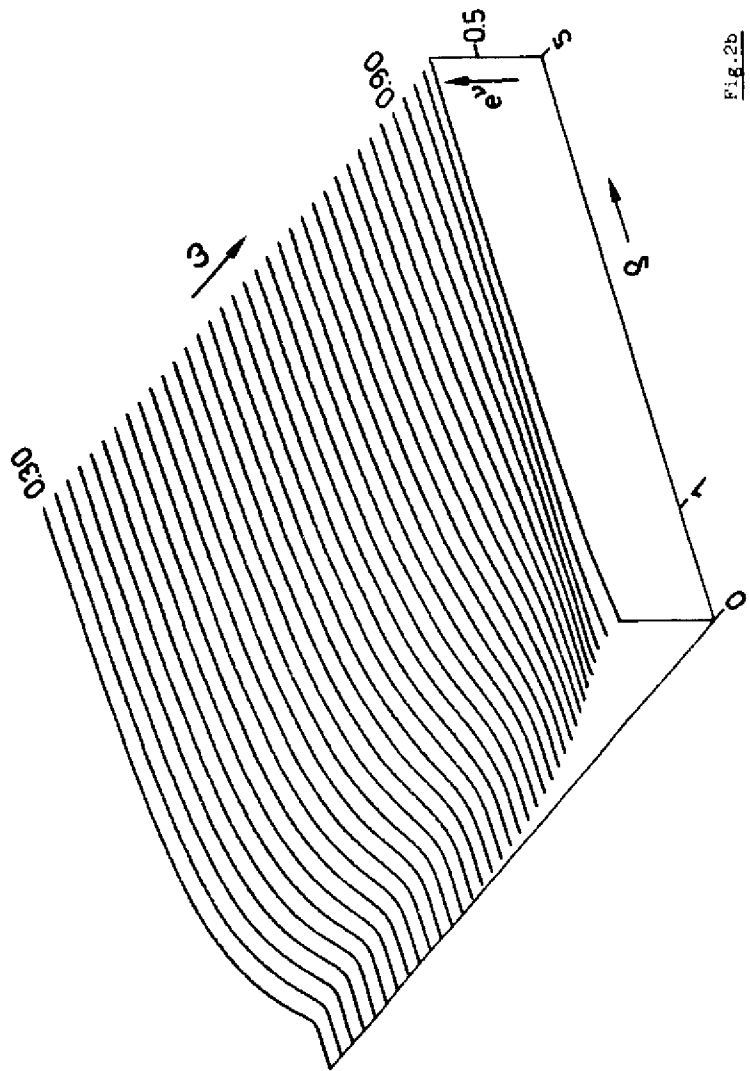

Fig. 2a



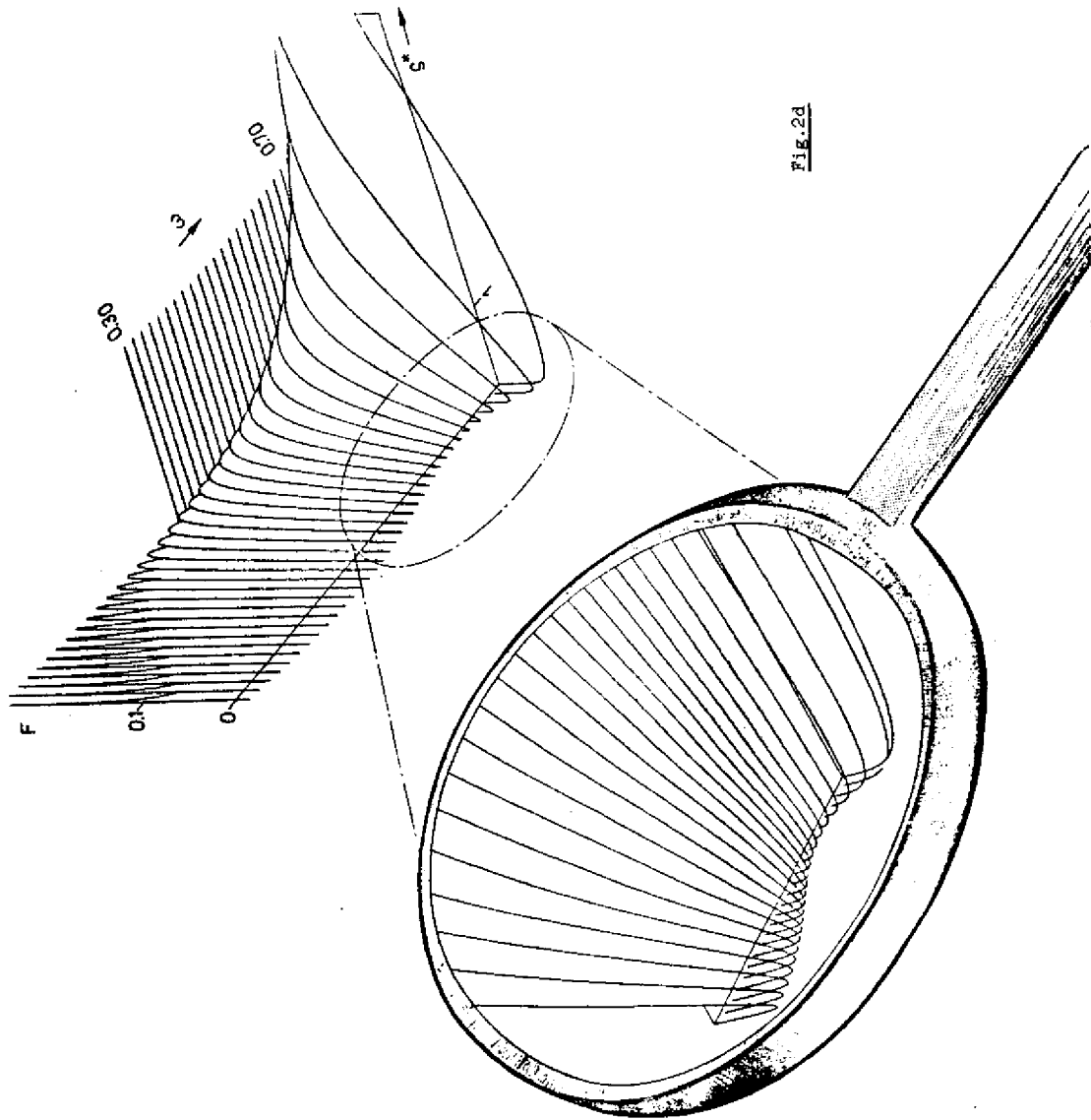

FIG. 2a

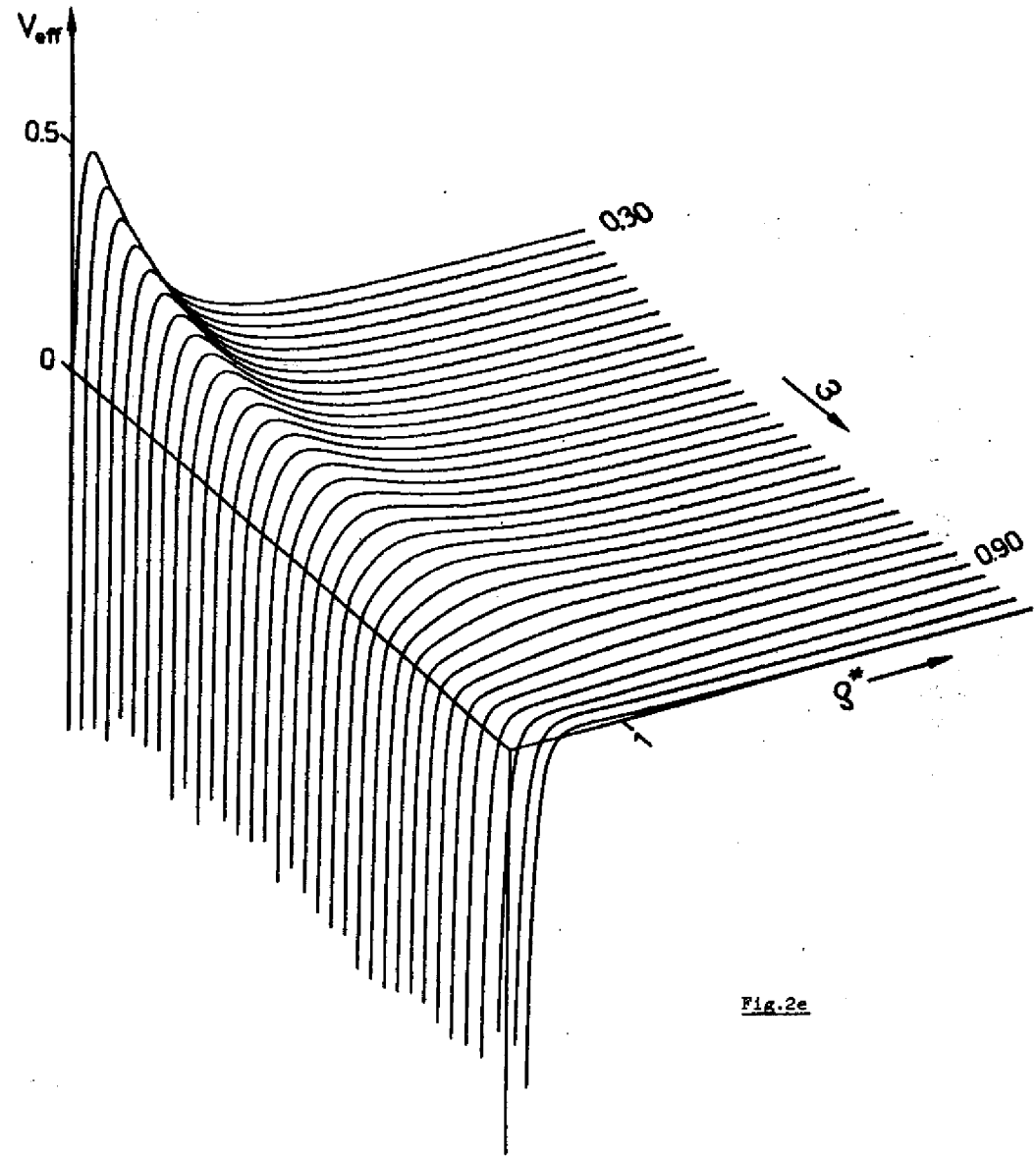

Fig. 2e

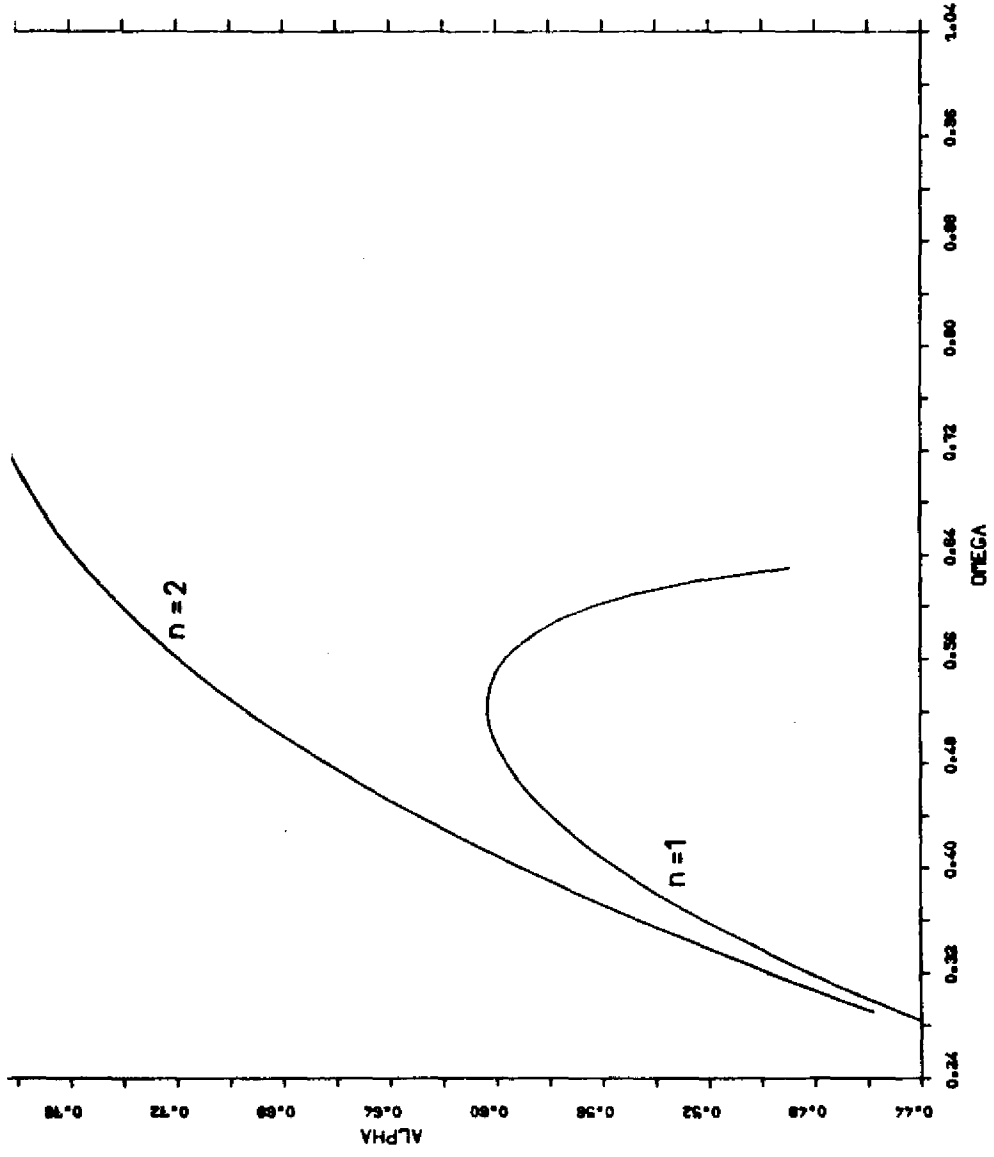

FIG. 3

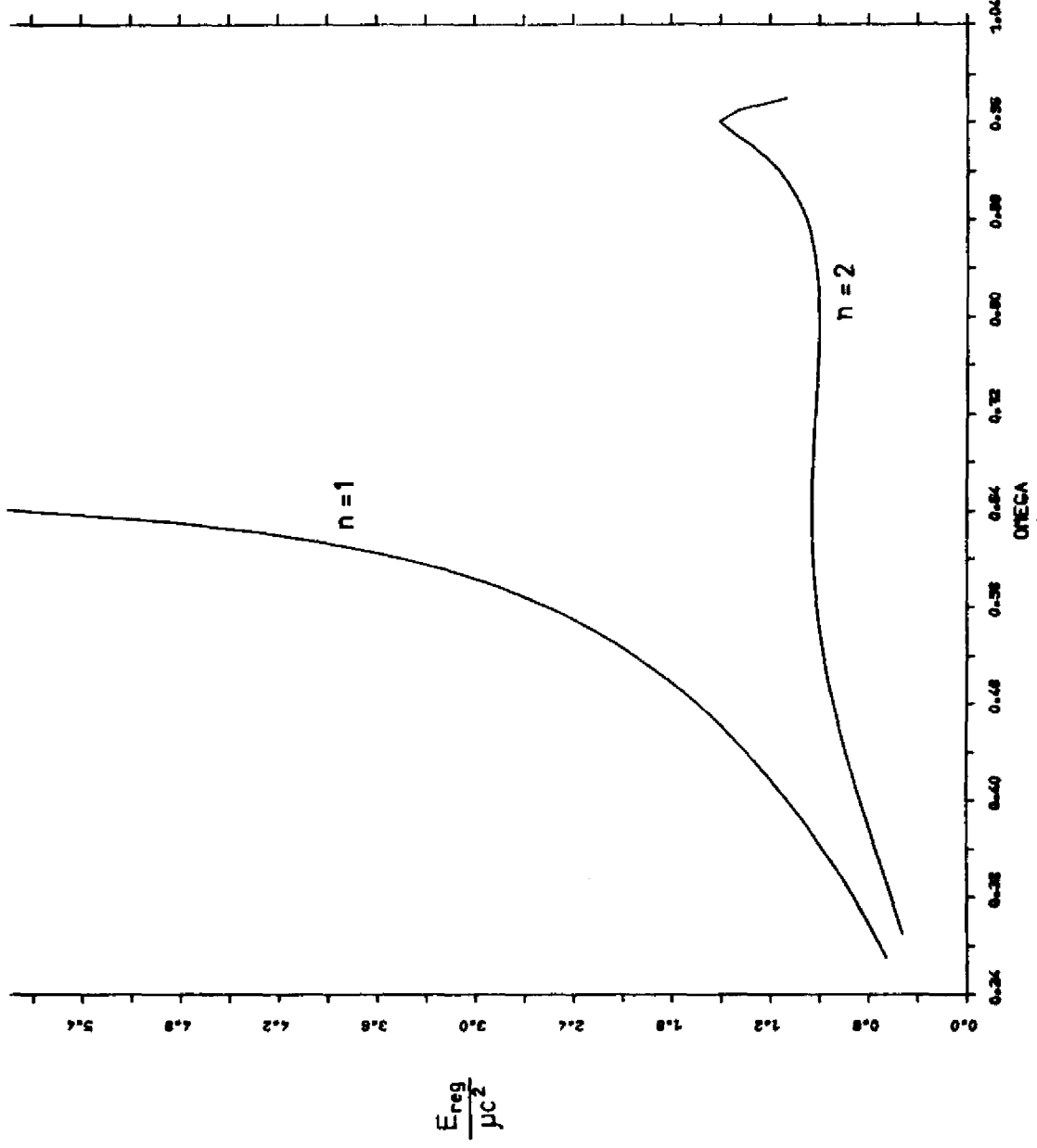

FIG. 4

- IC/80/2 A.P. BUKHVOSTOV and L.N. LIPATOV: Instanton-anti-instanton interaction in the $O(3)$ non-linear σ -model and an exactly soluble fermion theory.
- IC/80/3 RIAZUDDIN: $K \rightarrow 2\pi$ decays in non-relativistic quark-gluon model.
- IC/80/4 G. SENATORE and M.P. TOSI: Theory of the surface dipole layer and of surface tension in liquids of charged particles.
- IC/80/15 S. RAI CHOUDHURY: QCD effects in a model of non-leptonic hyperon decays.
- IC/80/21 NAMIK K. PAK: Electric charge as the source of CP violation.
- IC/80/22 T. NATTERMANN and J. PRZYSTAWA: Locking-in and incommensurability of the structural transition in $BaMnF_4$.
- IC/80/29 E.W. MIELKE: On pseudoparticle solutions in Yang's theory of gravity.
- IC/80/32 ABDUS SALAM and VICTOR ELIAS: Induced Higgs couplings and spontaneous symmetry breaking.
- IC/80/33 INT.REP.* A. AMUSA: Point-triton analysis of exchange free direct two-nucleon transfer reaction cross-sections.
- IC/80/38 WITHDRAWN
- IC/80/39 ABDUS SALAM: The nature of the "ultimate" explanation in physics (Herbert Spencer Lecture - 12 November 1979).
- IC/80/43 V. de ALFARO, S. FUBINI and G. FURLAN: Classical solutions and extended supergravity.
- IC/80/47 J.C. PATI: Unity behind diversity in Nature.
- IC/80/48 J. LUKIERSKI: Supersymmetric σ models and composite Yang-Mills theory.
- IC/80/49 W. KROLIKOWSKI: Are lepton and quark families quantized dynamical systems?
- IC/80/50 W. DEPPERT: The role of interaction in neutrino statistics.
- IC/80/52 D. KUSNO and M.J. MORAVCSIK: On the problem of the deuteron shearing corrections - I: The conventional approach.
- IC/80/54 E.W. MIELKE: The eight-fold way to colour geometrodynamics.
- IC/80/55 A.R. HASSAN: Phonon-assisted transitions in crossed electric and magnetic fields.
- IC/80/56 A.R. HASSAN: Two-photon indirect transitions in crossed electric and magnetic fields.
- IC/80/57 S. NARISON: Techniques of dimensional renormalization and application to the two-point functions of QCD and QED.
- IC/80/62 N.S. CRAIGIE: Quantum chromodynamics - A theory of the nuclear force.
- IC/80/67 WITHDRAWN
- IC/80/68 A. AYENSU: Dynamic dislocations in high quartz.
- IC/80/69 INT.REP.* T. PERSI: Time dispersion relations and small-time behaviour in the decay of an unstable system.
- IC/80/70 M.F. KOTKATA, A.A. EL-ELA, E.A. MAHMOUD and M.K. EL-MOUSLY: Electrical transport and structural properties of Se-Te semiconductors.
- IC/80/71 INT.REP.* A.Yu. GROSBERG and A.R. KHOKHLOV: Some problems of the statistical theory of polymeric lyotropic liquid crystals.
- IC/80/72 J.C. PATI and ABDUS SALAM: Quark-lepton unification and proton decay.
- IC/80/73 ASHOK DAS: Are massless supersymmetric gauge theories really massless?
- IC/80/74 INT.REP.* G. MAIELLA: Chiral rotations and the fermion-boson equivalence in the Schwinger model.
- IC/80/75 J. SPALEK and K.A. CHAO: Kinetic exchange interaction in a doubly degenerate narrow band and its applications to $Fe_{1-x}Co_xS_2$ and $Co_{1-x}Ni_xS_2$.
- IC/80/76 INT.REP.* L.K. SHAYO: The generalized pressures on oscillating cantilever pipes conveying inviscid fluid.
- IC/80/77 E. GAVA, R. JENGO and C. OMERIO: Finite temperature approach to confinement.
- IC/80/78 INT.REP.* A. AYENSU: The dependence of mechanical, electrical, thermal and acoustic properties of tropical hardwood on moisture content.
- IC/80/79 J.S. NKOMA: Effect of impurities on the two-dimensional electron gas polarizability.
- IC/80/80 A.M. JAYANNAWAR and N. KUMAR: Orbital diamagnetism of a charged Brownian particle undergoing birth-death process.
- IC/80/81 INT.REP.* L.K. SHAYO: On the solution of the Laplace equation in the presence of a semi-infinite boundary - The case of an oscillating cantilever plate in uniform incompressible flow.
- IC/80/82 INT.REP.* E.R. NISSIMOV: Higher quantum conserved current in a new completely integrable model.
- IC/80/85 Tao RUIBAO and Pa FUCHO: A proof of the absence of modulated phase transition and spin density wave phase transition in one- and two-dimensional systems.

* Internal Reports: Limited distribution.

THESE PREPRINTS ARE AVAILABLE FROM THE PUBLICATIONS OFFICE, ICTP, P.O. BOX 586, I-34100 TRIESTE, ITALY.

- IC/80/86 INT.REP.* Pu FUCHO: Density of states, Poisson's formula of summation and Walfiaz's formula.
- IC/80/87 INT.REP.* A.K. BANDYOPADHYAY, S.K. CHATTERJEE, S.V. SUBRAMANYAM and B.R. BULKA: Electrical resistivity study of some organic charge transfer complexes under pressure.
- IC/80/88 INT.REP.* In-Gyu KOH and Yongduk KIM: Global quantity for dyons with various charge distributions.
- IC/80/89 K.G. AKDENIZ, M. GOODMAN and R. PERCACCI: Monopoles and twisted sigma models.
- IC/80/90 INT.REP.* A.R. HASSAN and F. Abu-ALALLA: Exciton-polarizations by two-photon absorption in semiconductors.
- IC/80/91 INT.REP.* A.R. HASSAN: Phonon-polaritons by two-photon absorption in solids.
- IC/80/92 INT.REP.* L. LONGA and J. KONIOR: Exact results for some 2D-Ising models with periodically distributed impurities.
- IC/80/94 INT.REP.* ABDUS SALAM and J. STRATHDEE: On Witten's charge formula.
- IC/80/95 INT.REP.* ABDUS SALAM and J. STRATHDEE: Dynamical mass generation in $(U_L(1) \times U_R(1))^2$.
- IC/80/96 H.S. CRAIGIE, P. BALDRACCHINI, V. ROBERTO and M. SOCOLOVSKY: Study of factorization in QCD with polarized beams and A production at large p_T .
- IC/80/97 K.K. SINGH: Renormalization group and the ideal Bose gas.
- IC/80/98 INT.REP.* HARESH DADHICH: The Penrose process of energy extraction in electrodynamics.
- IC/80/99 INT.REP.* G. MUKHOPADHYAY and S. LUNDQVIST: Dynamical polarizability of atoms.
- IC/80/100 INT.REP.* A. QADIR and A.A. MUFTI: Do neutron stars disprove multiplicative creation in Dirac's large number hypothesis?
- IC/80/101 INT.REP.* V.V. MOLOTKOV and I.T. TODOROV: Gauge dependence of world lines and invariance of the S-matrix in relativistic classical mechanics.
- IC/80/102 INT.REP.* Kh.I. PUSHKAROV: Solitary excitations in one-dimensional ferromagnets at $T \neq 0$.
- IC/80/103 INT.REP.* Kh.I. PUSHKAROV and D.I. PUSHKAROV: Solitary clusters in one-dimensional ferromagnet.
- IC/80/104 V.V. MOLOTKOV: Equivalence between representations of conformal superalgebra from different subgroups. Invariant subspaces.
- IC/80/105 MENDEL SACHS: On proton mass doublet from general relativity.
- IC/80/106 INT.REP.* L.C. PAPALOUCAS: Uncertainty relations and semi-groups in B-algebras.
- IC/80/109 INT.REP.* P. FURLAN and R. RACZKA: On higher dynamical symmetries in models of relativistic field theories.
- IC/80/111 INT.REP.* A. BREZINI and G. OLIVIER: Localization on weakly disordered Cayley tree.
- IC/80/112 S.K. OH: The Bjorken-Paschos relation in the unified gauge theory.
- IC/80/113 INT.REP.* A.A. PADLALLA: On a boundary value problem in a strongly pseudo-convex domain.
- IC/80/117 P. FAZEKAS: Laser induced switching phenomena in amorphous $GeSe_2$: A phase transition model.
- IC/80/118 P. BUDINI: On spinor geometry: A genesis of extended supersymmetry.
- IC/80/119 G. CAMPAGNOLI and E. TOSATTI: AsF_6 -intercalated graphite: Self-consistent band structure, optical properties and structural energy.
- IC/80/120 Soe Yin and E. TOSATTI: Core level shifts in group IV semiconductors and semimetals.
- IC/80/121 INT.REP.* D.K. CHATURVEDI, G. SENATORE and M.P. TOSI: Structure of liquid alkali metals as electron-ion plasma.
- IC/80/126 INT.REP.* The Seventh Trieste Conference on Particle Physics, 30 June - 4 July 1980 (Contributions) - Part I.
- IC/80/127 INT.REP.* The Seventh Trieste Conference on Particle Physics, 30 June - 4 July 1980 (Contributions) - Part II.
- IC/80/128 PARID A. KHWAJA: Temperature dependence of the short-range order parameter and the concentration dependence of the order-disorder temperature for Ni-Pt and Ni-Fe systems in the improved statistical pseudopotential approximation.
- IC/80/130 INT.REP.* A. QADIR: Dirac's large number hypothesis and the red shifts of distant galaxies.
- IC/80/131 INT.REP.* S. ROBASZKIEWICZ, R. MICNAS and K.A. CHAO: Ground-state phase diagram of extended attractive Hubbard model.
- IC/80/133 K.K. SINGH: Landau theory and Ginzburg criterion for interacting bosons.
- IC/80/134 INT.REP.* R.P. HAZOUME: Reconstruction of the molecular distribution functions from the site-site distribution functions in classical molecular fluids at equilibrium.
- IC/80/135 INT.REP.* R.P. HAZOUME: A theory of the nematic liquid crystals.
- IC/80/136 INT.REP.* K.G. AKDENIZ and M. HORTACSU: Functional determinant for the Thirring model with instanton