

## GEOTECHNICAL PROCESSES IN CLOSED OIL SHALE MINES

E. REINSALU\*, I. VALGMA

Department of Mining,  
Tallinn Technical University  
82 Kopli St., Tallinn, 10412 Estonia

*During the years 1998–2001 geotechnical processes in closed underground oil shale mines and opencasts were investigated. In addition to kukersite oil shale deposit, the closed Sillamäe uranium (Dictyonema shale) mine was prospected. The main tools and methods included mine plans, aerial photographs and Geographical Information System data. 290 km<sup>2</sup> of underground and 130 km<sup>2</sup> of strip-mined areas were studied. The mining maps of Estonian underground and surface mines were created. The stability of underground mined area, where room-and-pillar method was used, was the main objective of the study. It was studied with the help of aerial photographs, mine drawings, maps of quaternary sediments and mathematical modeling of rock failure. The main results are: 20 % of subsidences remain undiscovered and 42 % of subsidence occurrences have no remarkable influence to the land cover; the probability of subsidence remains and may increase in the case of mine drowning. As several mines will be closed during the next few years, the problems of drowned waste (which were not subjects of this study) are going to be more actual than before: increasing underground water level, pollution of underground water, formation of technogenic water sources, overflowing of reclaimed areas, etc.*

There are two kinds of oil shale in Estonia: kukersite as the principal one and Dictyonema argillite (black oil shale, alum shale) as uranium shale. Both oil shales are deposited in low depth and their fields are large. Kukersite oil shale deposits cover more than 5 % of Estonian mainland. There are fourteen closed and/or abandoned underground mines (including two Sillamäe uranium mines) and nine partly reclaimed kukersite open casts today. The total area of mined-out lands exceeds 400 km<sup>2</sup> that is less than 1 % of the Estonian area.

In Estonia since the year 1916 almost 1 billion tonnes kukersite oil shale has been extracted, approximately 2 billion m<sup>3</sup> overburden has been excavated and about 200 million m<sup>2</sup> underground workings have been formed.

---

\* Corresponding author: e-mail [ere@cc.ttu.ee](mailto:ere@cc.ttu.ee)

Between 1949 and 1952 Dictyonema oil shale was mined in Estonia for the production of uranium in the Sillamäe uranium processing plant. Since there was a lack of stripping excavators suitable for open-cast mining in the USSR, an underground mine was dug. The average depth of the mine was 14 m. The average thickness of the horizontally lying argillite bed was 1.24 m. Mining was carried out by the roof caving method. Altogether, 240.5 thousand tonnes of ore with an average uranium content of 0.036 % was extracted that makes the potential yield of 63.3 tonnes of the metal. The mine was not closed completely until 1969. The land above the mine is now a typical subsided wasteland. One of the closed vertical shafts is fallen open. In the field there are some open cave-ins.

We have classified all underground mined areas as steady, subsided, stable and quasistable land [3].

**Steady land** is located on the mining claims but is unmined because of protective or remnant pillars (Fig. 1). The area of the steady land is always smaller than the area of the pillar.

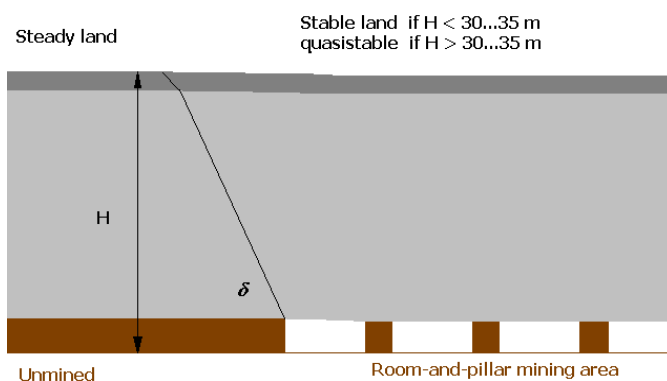

Fig. 1. Steady, stable and quasistable land

**Subsided land** is located above the hand-mined area: advancing-and-retreating mining and longwall mining with double-unit-face areas (Fig. 2).

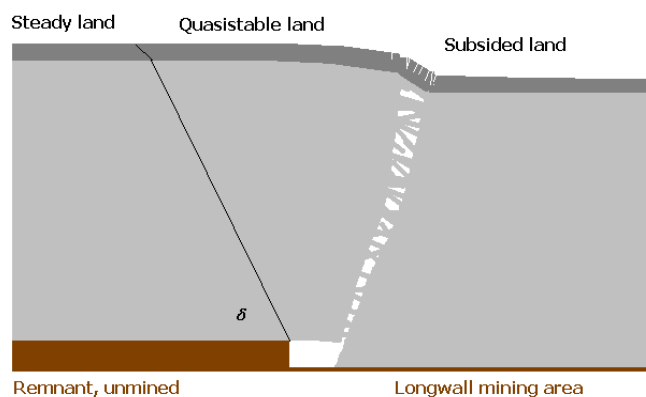

Fig. 2. Steady, quasistable and subsided land

The relief of subsided land depends on the quantity of the filling material and filling quality, and on the roof structure. Mining technology and mining conditions used could characterize subsided land in an oil shale deposit. Backfilling was used together with the double-unit-face methods in the eastern part of *Ahtme* mine, and in Kiviõli, Küttejõu, Kukruse, Käva and Ubja. In parts of *Kohtla*, *Sompa*, *No. 2* and *No. 4* mines the breaking edge support was used in the low seam. The same was tested and used in the high seam in *Ahtme*, *Kohtla*, *Sompa*, *Estonia*, *No. 2* and *Tammiku* mines. Initiated caving of blocks of rooms was tested in *Ahtme* and *Viru* mines.

**Stable land** is located in pillar-protected areas (see Fig. 1). Land stability depends on the strength of pillars. The width of rooms and drifts is the second stability factor. These spaces may be so narrow that caving could not reach the land surface. Vertical ground movement may reach 20 mm in stable land, and horizontal one even less. These movements are caused by compression of pillars or by consolidation of soil because of draining or seismic effects of blasting. There is no secondary subsidence on the stable area. Stable land covers the rooms whose pillars were not been mined before abandoning, and thickness of the hard roof remains in the range of 10–35 m. Secondary subsidences may occur in the areas with thinner limestone cover. Stable land is located in the room-and-pillar mining area of *Käva*, *No. 2* and *Tammiku* mines.

**Quasistable land and area** forms in places where pillars keep mine workings during mining but may break afterwards (Fig. 3).

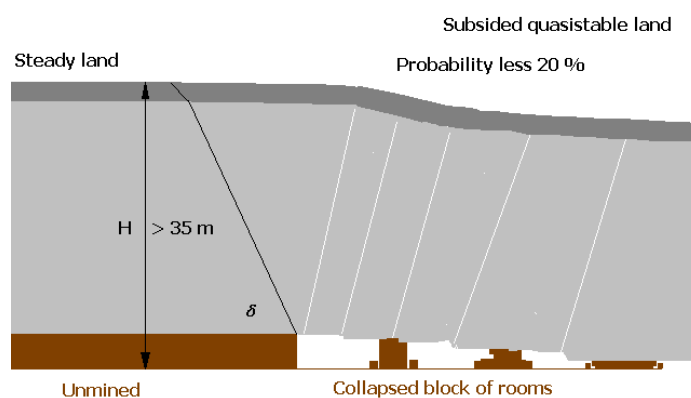

Fig. 3. Steady and quasistable land

All the room-and-pillar mining area that is unstable is quasistable. This is the area in *Ahtme*, *Estonia* and *Viru* mines where hard roof thickness exceeds 30–35 m. Quasistable areas occur also by sides of caved longwall mining areas (see Fig. 2), and above drifts, adits, and galleries on low-depth mining area (Figs 4 and 5).

Land usage depends on the land type. The main limitations are shown in the Table.

**Limitations for Building and Land Usage  
Depending on the Type of Underground-Mined Land**

Type of land	Buildings, roads, etc	Agricultural and forest land
Steady	No limitations	
Stable	Only light buildings	No limitation
Subsided	Considering the possibility of size and nature of land deformations in the future	Considering possible changes of humidity regime, especially unfavourable composition of Quaternary sediments
Quasistable	Generally building is forbidden, permission only for the project which has passed geotechnical expertise	Considering the risk of cultivated plant destroying, especially unfavourable composition of Quaternary sediments

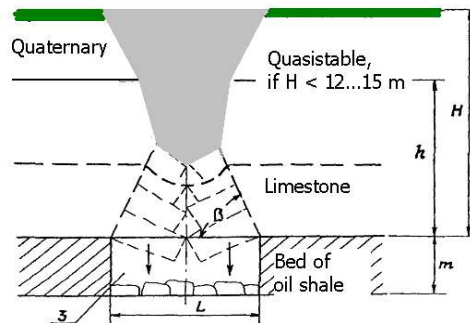

Fig. 4. Quasistable land above the drift in low-depth-mined area. Roof failure section by A. Toomik [4]

Fig. 5. Failed roof of a drift in the *Sillamäe* uranium mine

It is not possible to give general recommendations for land usage, or to compose maps describing large areas. Every specific case has to be solved separately, depending on the mining conditions and method. A corresponding example is shown in Fig. 6.



Fig. 6. Layout of mined land in Kohtla. Legend: 1 is steady land, 2 – stable land, 3 – quasistable land, 4 – subsidized land

The calculations of land cover situation were done for the southern part of *Kohtla* mine. The purpose was to establish which types of land stability characterize the areas forming after longwall mining. The initial data included a digital map of longwall-mining blocks, various kinds of remnants, faults, drifts and blocks of rooms. In this area steady area forms above the remnants – unmined karst zones and protective pillars. Stable land is located above the drifts and their pillars between the blocks of rooms. Quasistable area forming by sides of the border of the caved area is 34 m wide at this locality. Buffer zones were created around the borders of longwall-mining

blocks depending on the thickness of limestone and soft cover. The 1-m bottom of the subsidence moulds is subsided land.

## Conclusions

The main objective of the study was the stability of the underground-mined area mined by room-and-pillar method. The main results of our investigations are as follows:

- Quasistability of the mined area is the problem of an underground mine. 20 % of subsidences remain undiscovered and 42 % of the subsidence occurrences have no remarkable influence on the land cover.
- The probability of subsidence remains and may increase in the case of mine drowning.
- Building on the underground-mined area should follow the regulations foreseen by mine layout.
- Land and forest damages are only occasional cases on the area of oil shale underground mines nowadays recovered to wildlife.

## Acknowledgements

The study is supported by Grant No. 3403 (in 1998–2000), recommendations and limitations are worked up by support of Grant No. 4870 (in 2001–2003) by the Estonian Science Foundation.

## REFERENCES

1. *Valgma, I.* Geographical Information System for Oil Shale Mining – MGIS : Doctoral thesis on mining engineering. <http://www.ttu.ee/maeinst/mgis> // Tallinn Technical University. 2002.
2. *Valgma, I.* Map of oil shale mining history in Estonia // Proc. II. 5th Mining History Congress, Greece, Milos Conference Center – George Eliopoulos, 2001. P. 198–193.
3. *Reinsalu, E., Toomik, A., Valgma, I.* Mined-Out Land. – Tallinn : Department of Mining of TTU, 2002 [in Estonian, see the abstract in English at: Oil Shale, 2002. Vol. 19, No. 4, P. 442).
4. *Toomik, A.* Assessment of the impact of underground mining on the ground surface // Impact of Oil Shale Mining and Processing on the Environment in North-East Estonia / Institute of Ecology TPU, Publication No. 6. 1999. P. 109–129 [in Estonian, extended summary in English].