

GIS approaches to regional analysis: A case study of the island of Hvar

Vincent Gaffney and Zoran Stančič with preface by Kenneth Kvamme
Znanstveni institut Filozofske fakultete Ljubljana, 1991 (reprinted in 1996)

You can order this book at

Oxbow Books
Park End Place
Oxford, OX1 1HN, UK

Tel: (044)-1865-241249
Fax: (044)-1865-794449

E-mail: oxbow@patrol.i-way.co.uk

WWW: www.oxbowbooks.com

CONTENTS

Illustrations

Preface

Introduction

Section one: The concepts and components of Geographical Information Systems

1. GIS - introduction and definition
2. The components of GIS
 - 2.1. Hardware
 - 2.1.1. Data input devices
 - 2.1.2. Remote sensing
 - 2.2. Software
 - 2.2.1. The data acquisition modules
 - 2.2.2. Data processing modules
 - 2.2.3. Analytical modules
 - 2.2.4. Data presentation modules
3. GIS data
 - 3.1. Vector vs. Raster GIS
4. GIS and Archaeology
5. Choosing a Geographic Information System
6. GIS software and hardware used in the case study

Section two: The Hvar case study

1. The study area
2. The environmental data base
 - 2.1. DEM
 - 2.2. Soils
 - 2.3. Lithology
 - 2.4. Micro-climate
3. The Hvar archaeological database
 - 3.1. Previous archaeological work on the island
 - 3.2. An outline of the archaeology of Hvar
 - 3.2.1. The Neolithic period
 - 3.2.2. The Bronze Age
 - 3.2.3. The Iron Age
 - 3.2.4. The Greek Period
 - 3.2.5. The Roman Period
 - 3.2.6. The Post Roman period
 - 3.3. The archaeological database
4. GIS approaches to the archaeology of Hvar
5. GIS approaches to territorial boundary definition
6. Cairns and tumuli; agricultural clearance or ritual activity
 - 6.1. Problems in the definition of stone cairns and tumuli
 - 6.2. The analysis of stone cairns on the island of Hvar
7. Roman villas in the landscape
8. The Greeks on Hvar: optimal paths and visibility analysis in archaeology
9. Neolithic settlement on Hvar: archaeological limitations and GIS applications
10. GIS and heritage management
11. Concluding comments

Appendix: Codes used in the Hvar sites and monuments register

Bibliography

ILLUSTRATIONS

1. GIS hardware
2. The digitiser
3. The scanner
4. The electromagnetic spectrum
5. Examples of information derived from the Digital Elevation Model (DEM)
6. GIS data layers
7. Raster representation of vegetation data layer
8. Flow chart representing GIS information paths
9. Location of the island of Hvar within Europe
10. The Hvar DEM
11. Simplified soil map based on agricultural potential
12. Pie chart illustrating soil classes on the island of Hvar
13. Lithological map of Hvar
14. Pie chart illustrating lithology classes on the island of Hvar
15. Microclimate zones
16. Neolithic findspots on the island of Hvar
17. Bronze Age findspots on the island of Hvar
18. Iron Age findspots on the island of Hvar
19. Greek findspots on the island of Hvar
20. Roman findspots on the island of Hvar
21. Distribution of hillfort sites with boundaries defined through GIS modules
22. Traditional site catchments for hillfort sites
23. Traditional and GIS derived catchments for the Gracisce hillfort
24. Traditional and GIS derived catchments for the Hvar Castle hillfort
25. GIS catchments for major hillfort sites on the island of Hvar
26. Gracisce catchment and soil types
27. Hillfort catchments and soil types on the island of Hvar
28. Relative size of hillfort catchments in hectares
29. Hillfort sites and pie charts illustrating the proportion of soil types within individual catchments
30. Soils and hillfort catchments including the Umic site
31. The distribution of stone cairns
32. The distribution of tumuli
33. Cairns and tumuli: expected and actual occurrences against soil type
34. Cairns and tumuli: expected and actual occurrences against lithology
35. Cairns, tumuli and the Gracisce catchment
36. Cairns, tumuli and the Hvar Castle catchment
37. Tumuli within the bay at Vira (after Zaninovic 1978b)
38. The distribution of cairns and tumuli within hillfort catchments on the eastern part of the island of Hvar
39. Correlation of Roman settlement sites and soil types
40. Correlation of Roman settlement sites and climate
41. Roman settlement sites, climate and soil ranked by chi square value
42. GIS derived model for Roman settlement
43. The distribution of Roman settlement sites on the Stari Grad plain
44. The distribution of Roman settlement sites and soil groups on the Stari Grad plain
45. The distribution of Roman settlement sites and lithologies on the Stari Grad plain
46. Roman settlement sites and soils on the Stari Grad plain: expected and actual occurrence
47. Roman settlement sites and lithology on the Stari Grad plain: expected and actual occurrence
48. Roman sites with pie charts illustrating the proportions of soil types within GIS derived catchments
49. GIS derived territory and soil types for the Roman site at Dolcic
50. Visibility analysis based on the Greek tower at Maslinovik
51. Cost surface analysis between Pharos and the tower at Tor
52. Optimal path between Pharos and the tower at Maslinovik
53. Neolithic cave sites on Hvar
54. Soil types within neolithic cave site catchments
55. Soils and lithologies within the catchment of the cave site of Vela spilja
56. Soils and lithologies within the catchment of the cave site of Markova spilja
57. Land surface falling within the catchments of neolithic cave sites
58. Neolithic cave sites and lithology on the island of Hvar
59. Levels of destruction on archaeological sites on Hvar
60. Excavated sites on Hvar
61. Slightly damaged sites on Hvar

- 62. Badly damaged sites on Hvar
- 63. Totally destroyed sites on Hvar

ACKNOWLEDGEMENTS

We would like to acknowledge all the help, finance and encouragement given by the following individuals and institutions without whom we would not have been able to complete this volume. Lots of beers and lots of fun. The staff of the Arkansas Archaeological Survey especially; Dr. F. Limp, J. Lockhart, R. Harris, J. Fairley, I. Williams, The Department of Archaeology, The University of Ljubljana, The Department of Archaeological Sciences, University of Bradford (Great Britain), The Centre for the Protection of the Cultural Heritage of the Island of Hvar, The British Council, The British Academy, The Archaeological Museum in Split, The Department of Archaeology, University of Reading (Great Britain), The Urban Institute of the Republic of Croatia, Dr. J. Bintliff, Dr. F. Carter, Dr. B. Slapsak, Dr. J. Hayes, Dr. G. Bozovic, Dr. P. Sivic, Prof. M. Fulford, S. Levi, B. Kirigin, M. Kolumbic, M. Petric, N. Vujnovic, J. Kovacic, N. Petric, H. Watson, T. Grajf, K. Predovnik. Special thanks to G. Burrows for the cartons.

Finally, we should thank the staff and students of the universities of Ljubljana, Bradford, Belgrade, Zagreb and Skopje who did all the real work, collecting the data.

PREFACE

It is incontrovertible that the study of archaeology implies, by its very nature, the investigation of spatial distributions: archaeological cultures are associated with particular localities on a continental scale; sites of past occupation have location within regions; and artifacts have spatial positions within sites.

It is also equally true that archaeologists generally are slow to incorporate new technologies into their research repertoires -- we have an intense focus on the past, after all, which perhaps inhibits us from looking forward. There are notable exceptions to this rule, however, and the present volume is a case in point. GIS APPROACHES TO REGIONAL ANALYSIS: A CASE STUDY OF THE ISLAND OF HVAR presents one of the first concrete applications of a relatively new computer technology known as Geographic Information Systems (GIS) in archaeology.

GIS are software systems specifically designed for handling data that have a spatial, or mappable, component. As such, they are ideally suited for the handling, manipulation, and analysis of archaeological data regardless of their context, scale, or setting. Moreover, since archaeologists have a long tradition of map-making -- maps are made of artifact distributions within structures, structures within settlements, and settlements within regions, for example -- they will appreciate the cartographic capabilities of GIS. As this volume so amply illustrates, GIS can produce maps in a variety of formats, scales, and colors that greatly facilitate regional research because maps can be obtained very rapidly allowing ready portrayal of data, and spatial relationships between various phenomena can easily be recognized when they are viewed in map form.

Gaffney and Stančić are greatly concerned with transmitting an understanding of the fundamental principles and concepts of GIS. In Section One they present a knowledgeable overview of the technology including descriptions of hardware devices, the various software components, system design issues, data capture methods, and fundamental GIS operations. They are to be commended for this effort which will be welcome reading for the novice.

The real contribution toward influencing archaeological opinion about the potential of GIS in regional studies lies in the excellent applications examples, which form Section Two of the volume. Drawing from the diverse and well-documented archaeology of the Island of Hvar, on the Dalmatian Coast of Yugoslavia, several case studies are presented that focus on various domains fundamental to landscape analysis and regional archaeology.

Site Catchment Analysis is applied to investigate the distributions of Bronze and Iron Age hillforts and later, to Neolithic cave sites. In these applications GIS provide a substantial deviation from the traditional approach that relies on simple circular catchments. Using computer models of the terrain surface, movement difficulties, and travel times, more realistic approximations of travel cost catchments are achieved that often are irregularly shaped owing to the influence of terrain on travel. The outcome provides a new and improved perspective on this form of analysis that can yield profoundly different conclusions. The authors are overly modest when they suggest that these studies might have been undertaken manually; without GIS the sheer number of computations required to obtain an accurate result would be beyond manual means.

GIS also facilitate the statistical analysis of site location tendencies, as illustrated by two case studies. In one, the distribution of stone cairns and tumuli, ranging in age from the early Bronze Age to the first century BC, are shown to bear a strong statistical relationship with the best agricultural lands. Since nearly 50 percent of these large stone piles bear no evidence of burials when excavated, this association lends considerable support to the hypothesis that many of these features simply are the result of past agricultural field clearance practices rather than funerary monuments. Similar analyses undertaken for the later Roman Villa occupation illustrate pronounced statistical correlations with the best agricultural lands, climatic settings, and certain geologic conditions that helped promote this largely agricultural system.

Perhaps the best exposition of the power of GIS for archaeological settlement studies lies in the analysis of the Greek period occupation. The Greeks, confined principally to the settlement of

Pharos on Hvar, were apparently in a state of perpetual competition and conflict with their Illyrian neighbors. Two watchtowers, located some distance from Pharos, quite likely provided a system whereby the town could be alerted of approaching danger, probably through the use of smoke signals. GIS-based line-of-sight and intervisibility studies using a digital representation of landform clearly show that these towers were visually linked with Pharos and that they provided a view of substantial portions of the surrounding region, thereby offering an early-warning system.

Judging from the enthusiasm of the authors and the many archaeological insights they gain from their employment of GIS, it seems clear that GIS-based regional studies will soon become a regular feature of modern archaeology. Archaeologists must deal with vast amounts of spatial information in regional work and GIS are designed specifically for the handling and manipulation of spatial data. Consequently, GIS and archaeology may represent an ideal marriage.

Kenneth L. Kvamme University of Arizona May, 1991

INTRODUCTION

A recent review of the use of Geographical Information Systems (GIS) quoted a British Government report which stated that the impact of GIS on spatial analysis was as significant as, "the invention of the microscope and the telescope were to science, the computer to economics and the printing press to information dissemination. It is the biggest step forward in the handling of geographic information since the invention of the map." (DoE. 1988,8 in Harris and Lock 1990)

One would think that any product with such a billing would have been welcomed with open arms by archaeologists throughout the world. The manipulation of spatial data has, after all, been the bread and butter of archaeologists for decades. Despite this fact, widespread adoption of GIS has not been the case. There has been a significant delay between the development of the techniques in North America and their application elsewhere in the world. The reasons for this gap are many. The initial cost of hardware and software was undoubtedly a problem. Key institutions have been resilient to the use of GIS and widespread ignorance of the existence or the potential of the technique amongst archaeologists has been notable until very recently.

This situation is changing. The falling cost of both software and hardware places some form of GIS within the reach of virtually all institutions and there are increasing numbers of computer literate archaeologists who are both willing and capable of using GIS to the full. Despite this, the progress of GIS within European archaeology at least is likely to remain a slow process, a problem exacerbated by the arcane nature of the literature and the difficulty in acquiring so much of it.

This monograph is an attempt to introduce GIS to a wider audience within Europe. No attempt has been made to provide a handbook to GIS applications or a review of available hardware and software, (although the references within the text lead to such information). The intention is simply to give the reader some insight into the potential of GIS for archaeological application. The first section introduces basic components and concepts of GIS, some of which may be unfamiliar to the general reader. The second applies selected GRASS (Geographical Resources Analysis Support System) GIS modules to an archaeological and environmental database relating to the island of Hvar in Dalmatia, Yugoslavia. The problems approached within this section include; territorial boundary definition, the analysis of communication routes and the relationship of archaeological sites to agricultural land within their economic territories. Although the data used is specific to Yugoslavia and the karst region of Dalmatia, the research themes are general to most periods and areas of archaeological research and will be familiar to most archaeologists. Consequently, we hope that readers will interpret the results we have achieved in the light of their own interests. We should also stress that we have deliberately included several instances where the analyses were not as successful as we had hoped, generally the result of inadequacies in the archaeological or environmental databases. In doing so we hope that we can help others avoid some of the pitfalls which we ran headlong into.

Vincent Gaffney Department of Archaeology, University of Reading, Great Britain

Zoran Stančič Department of Archaeology, University of Ljubljana, Slovenia

SECTION ONE: THE CONCEPTS AND COMPONENTS OF GEOGRAPHICAL INFORMATION SYSTEMS

1. GIS - INTRODUCTION AND DEFINITION

The presentation of spatial data in map form has a long history. Until recently the production of such maps was often in the hands of civil authorities or military institutions, a reflection of the importance placed upon the possession of such information. Data collection for these early maps was a slow and expensive manual process. The graphical representation of data within such maps was, however, generally considered adequate because of the relatively slow rate of change within society. Consequently, the maps produced by such societies retained their value and might be used for decades.

Today, the increased rate of change within modern societies has created a need for faster and more efficient data collection and this has led to the development of new collection techniques. Photogrammetric plotting, for example, was developed within the arena of topographic mapping, but even this involved the presentation of different data types as a series of separate maps. Gradually the demand for computer storage of spatial information grew, along with the need for systems which allowed the easy retrieval of such data for the production of thematic maps. This goal has only been possible as a result of the startling development of computer design during the 1960's and 1970's. These changes allowed the initial development of Geographical Information Systems (GIS). The origins of GIS are to be found within the development of Computer Aided Mapping (CAM) during the 1970's. CAM is a technique which allows fast and qualitative map production. It is primarily directed towards quality graphic representation of data. GIS goes beyond this and is a computer aided system for the collection, storage, retrieval, analysis and presentation of spatial data (Clarke 1986). It incorporates the capabilities of CAM, computerised databases and statistical packages, but differs significantly in its structure and purpose.

CAM for instance, is concerned with faster and cheaper map production. Although early CAM programmes did allow limited analysis, manipulation and output of spatial data through line printers, the map remained the primary goal of information storage and display. Computer run databases, alternatively, enable the manipulation of spatial data but have limited capabilities, for collection, analysis and presentation. GIS, however, can be better understood as a computer database with CAM capabilities but which incorporates the ability to carry out statistical analysis of spatial data. GIS is further separated from these other systems by its ability to generate new information based on the data held within it (Cowen 1987).

The increased demand by modern societies for collection, analysis and presentation of rapidly updated spatial information has spurred on GIS development, a process which has involved many related disciplines (see Parent and Church 1987 for a discussion of this development). Indeed it could be said that GIS should be viewed not as a system but a technology, a technology based upon developments within cartography, computer graphics, computer aided design (CAD), photogrammetry, geodesy, remote sensing and related fields. As a result of this GIS has been rapidly adopted by disciplines with an interest in the analysis of space, for example in the fields of cadastral analysis, environmental protection, documentation of service networks including electrical supplies and most aspects of urban planning. Some archaeologists have also been quick to apply GIS. The large amounts of data generated by archaeology has necessitated the application of computer aided documentation. The spatial nature of much of this data, artifacts within a site, sites within a region or cultures distributed across a landmass, invite GIS applications. Indeed the full potential of spatial analysis within archaeology including intra site analysis, regional settlement studies and cultural heritage management is probably not realisable without the use of GIS.

2. THE COMPONENTS OF GIS

Within this chapter we will outline the principal components of GIS. In order to do this we must view GIS within the context of the hardware/software configurations which produce the best results. In this monograph we will concentrate on the hardware and software, further detail on GIS organisation can be found within Burrough (1986).

2.1. Hardware

GIS, like every other computer system, utilises a series of devices for data input, central processing, data storage and data output (figure 1). With the exception of data input these devices are not specific to GIS, but they should be mentioned briefly.

The central processing unit, the brains of the system, controls data manipulation as well as input, output and storage. Storage devices such as diskettes, disks and tapes are magnetically based. However, these are currently being replaced by optical storage media.

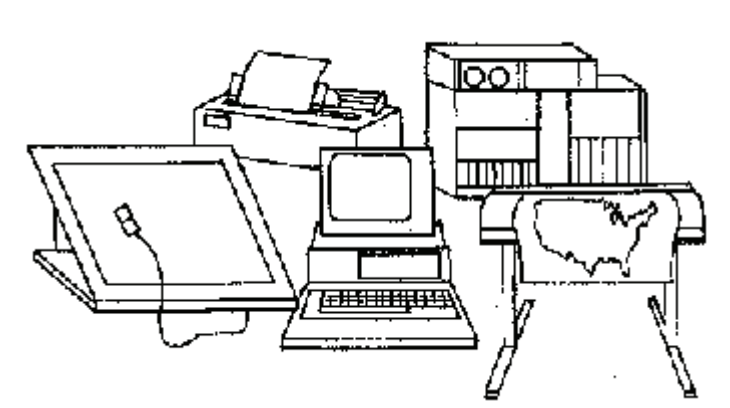

Figure 1. GIS hardware

Output devices include monitors, printers and plotters. Within GIS two types of monitor are normally in use; a high resolution graphical monitor and a text monitor. The text monitor is used for basic computer/user communication. It enables basic text output and is monochrome. The high resolution graphic monitor provides quality images. Several types of monitor are currently available which vary in screen size, resolution and the numbers of available colours.

Printers are used for text output and map plotting. The resolution and monochrome nature of many printers means that output is often not of a very high quality. Some colour printers are now available that can provide better results. However, the best output is provided by plotters. Plotters produce high quality line maps. The major disadvantage of such plotters is their relatively high price.

2.1.1. Data input devices

Principal data input devices are the keyboard, the digitiser and data from remote sensing. Although the keyboard is the principal communication device, the ability to use high resolution data within GIS relegates it's role to communication with the CPU and elementary data entry. Data input from maps is carried out by digitisers.

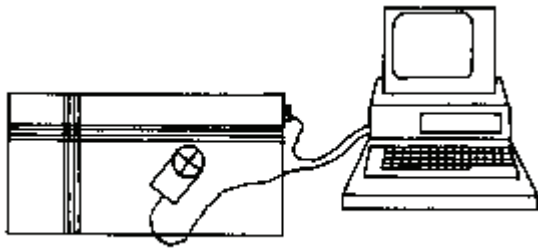

Figure 2. The digitizer

Digitising devices may be either scanners or co-ordinate digitisers. Flat board co-ordinate digitisers (figure 2) are usually equipped with a pointing device which can record the co-ordinates of any desired point upon the board. Board digitisers are produced in a variety of sizes but they usually range between 30 x 40 cm. and 120 x 150 cm. and are accurate between 1 and 0.1mm. The most simple digitisers demand that every point is inputted individually via the pointer to the computer. A shape is approximated as a set of individually recorded short lines forming a polygon. Available software can alleviate the tedium of data inputting. This arduous task is made easier if the digitiser uses a stream mode. Here the pointer follows the line and co-ordinates are directly transferred to the computer. Using this technique we do not have to discriminate between the individual sections of the polygon and digitise each part separately. We do however have to choose the resolution of the digitiser. This choice will be dependant upon the complexity of the line and the level of accuracy we seek. Having made this choice we simply inform the computer that we are digitising in stream mode and then follow the line. A "stream" of co-ordinate pairs will then be transferred to the computer. Recent developments in digitisers allow the machine to follow the line by itself. The operator "teaches" the digitiser to recognise the line and then need only control the procedure and act when the machine needs help. The digitisation of existing maps is very monotonous work. It is labour intensive and is often a source of errors (Ottawa 1987).

In particularly complex situations modern digitisers are not particularly useful, eg when digitising topographic maps. An alternative solution to this problem is the use of scanners. Scanners are automated systems which can read in entire maps as an image. They do not therefore store a series of co-ordinates of points or objects. Scanning is very fast but the resulting image has to be edited and cleaned. At this moment computers often cannot separate distinct structures such as rivers and roads on such images.

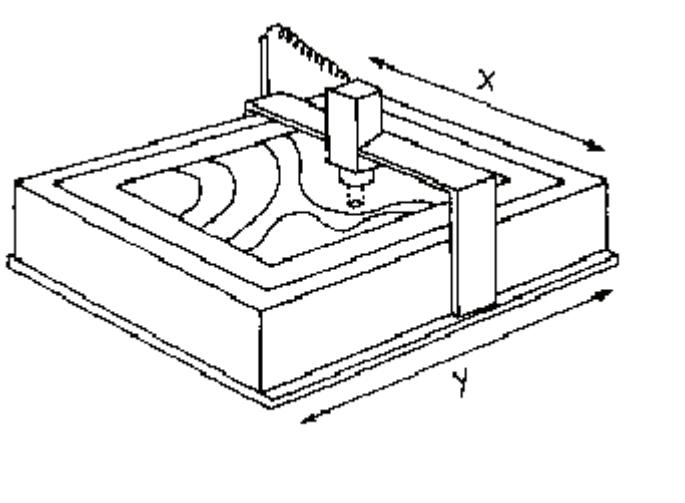

Figure 3. The scanner

There are a few scanner variants. The majority use a light sensitive device to scan the map in a series of stripes (figure 3). Other systems exist which enable input via video cameras.

Apart from the functional differences between scanners and digitisers and the differing labour input demanded by the two techniques, there is a wide difference between the costs of the respective hardware. Whilst the smaller, simplest digitisers cost about the same as a keyboard, the best may cost 100 times more and the better scanners 1000 times more. Although simple scanners may also be obtained at costs similar to the cheaper end of the digitiser market, they usually demand better software support and systems organisation (Blakeman 1987).

2.1.2. Remote Sensing

Up until now we have been concerned with hardware relating to the input of pre-existing graphical data in map form. When this information is not available it may be necessary to resort to remote sensing data. This information is usually obtained by aeroplanes or space satellites. Given the general confusion about the application of such data within archaeology it is worth considering the potential of such data in some detail.

Remote sensing covers those techniques which obtain information on objects, areas or phenomena via devices which have no contact with the subject under study. Here we should stress the role of non-photographic images acquired by sensors and not cameras. Such images have a variety of sources although satellite technology has been a major contributor to the development of remote sensing techniques and now produces the majority of such images.

ERTS-1 (Earth Resources Technology Satellite, renamed LANDSAT 1 in 1975) was launched in 1972 and began to gather systematic information which is now freely available. This has been followed by a number of American, Soviet and French satellites. Although we cannot deal with the minutiae of remote sensing technology here (see Colwell 1983 for further details), we can discuss some of the main characteristics of the images provided by such equipment. The quality of the image is defined by their resolution, a quality based on the pixel size and their spectral resolution. Objects smaller than the pixel cannot be seen on the image. LANDSAT 1 has a nominal pixel size of 57 x 79m., LANDSAT 4 and 5' thematic sensors provide a 30 x 30m. resolution and the French satellite SPOT has a pixel size 10 x 10m. and 20 x 20m.

The second characteristic of non-photographic sensors is their spectral resolution. Spectral resolution is defined as the capability of sensors to register certain bands of the electromagnetic spectrum. Such sensors usually have the capability to monitor not only that part of the electromagnetic spectrum which is visible to the naked eye but also a much wider band, and are usually capable of monitoring the near infra-red part of the spectrum (figure 4).

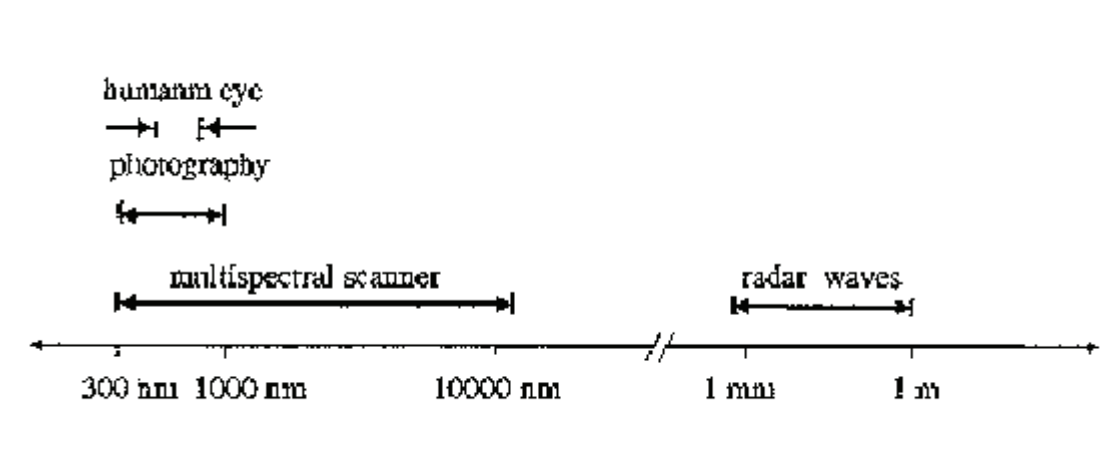
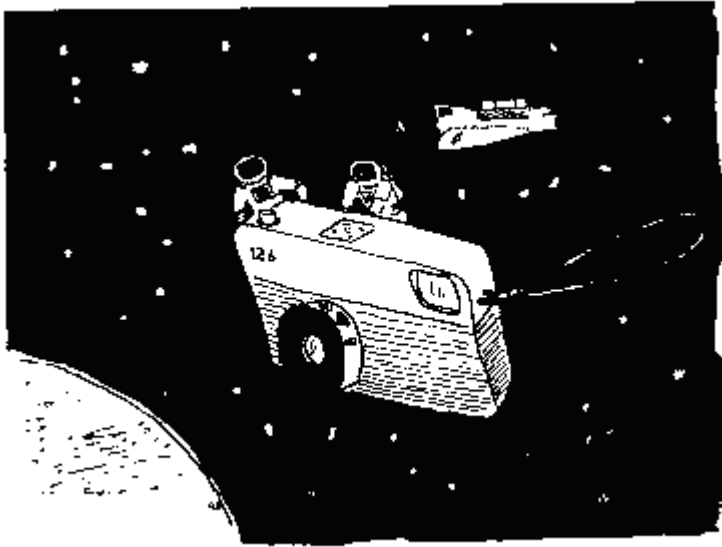

Figure 4. The electromagnetic spectrum

The potential of satellite imagery was readily seen and applied in a number of fields including archaeology. An early example of the exploration of satellite imagery was its use by Quann and Bevan (1977) to identify the pyramids. This example emphasises some of the limits of such images - the resolution of the image (the pixel size) is usually larger than the average archaeological site. Satellite images are therefore not very useful for the direct location of

archaeological sites (see Limp 1987; Farley et al. 1990 for further discussion of this point). Despite this, these images can be of enormous help. Archaeologists can use them to define physiographic regions, soil zones etc. and this images can then be combined with our knowledge of archaeological sites and their distribution to produce predictive settlement models (Lyons and Scovill 1978,9). We can therefore define two distinct approaches to archaeological data. One which is site based and a second which is problem oriented. In the first approach we ar generally asking where sites are, in the second why they are there. Given the problems associated with image resolution, it is within the latter area that satellite imagery will eventually prove the most useful (Custer et al. 1986).



Cartoon 1. If those archaeologists knew the truth about satellite images there'd be hell on.

Despite this, there are some areas in which remote sensing can contribute to site oriented research. Airborne non-photographic remote sensing, in particular, has potential within site oriented research because of the higher resolution of such techniques (Perriset and Tabbagh 1981; Hemans et al. 1987).

Within GIS, satellite images are treated as a data input source. Where cartographic information is not available or is not of high enough quality the use of such images is usually the best solution. For a few thousand U.S. Dollars an individual can purchase a multi band image of the area of the earth they are interested in. If correctly used these images can provide an enormous amount of information about the environment.

2.2. Software

Software is defined as the group of instructions which enable the execution of a certain procedure by a computer. A computer without software is a dead machine. Within this section we do not intend to discuss computer operating systems, this is of little value to the general reader, rather we will discuss characteristics which are shared by most GIS software packages.

GIS usually has a series of software modules which can be broken down into the following groups:

- the data acquisition modules
- the data processing modules
- the analytical modules - the data presentation modules

2.2.1 The data acquisition modules

The data acquisition modules enable data input within GIS. As we have already discussed, the information used in GIS comes from a series of sources and types. Satellite images may be used, different databases and a variety of maps, some of which may be of different scales and even different geographic projections. The module which controls communication with these inputs, especially with the digitiser, and transforms imported information into a form which is compatible with computer memory storage is therefore very important. This data must be collected in a form which can be edited and labelled in order to record not only spatial position but also the name and quality of data points. Modules for digitising have to be user friendly and allow the operator to concentrate on digitising with editing and labelling being carried out through the computer monitor. Data acquisition modules must also allow the direct input of satellite data. This is most often held on magnetic tapes. The images can then be re-processed via other modules.

These systems must also be able to input data held on other databases. Therefore, the GIS system must be able to communicate with other computers and to read and write data in a form that can then be inputted and supported by other specialist systems. Here we should emphasise the importance of integration between GIS, databases and specialist statistical packages. Careful consideration needs to be given to the integration of GIS and databases if they are to be used effectively (Farley 1989; Parker 1989). The communication process does not simply include the reading and writing of ASCII files. The system should be able to read data in such a form that no further manipulation is needed, eg when transferring data between different GIS packages or the importation of thematic maps which are already stored in a digitised form. Integration in this case means the ability to use specialist packages without the need to exit from the GIS.

2.2.2. Data processing modules

These modules process data prior to their use in specific analyses. The use of maps of different scales or cartographic projections demands the ability to transform the maps. These modules also transform data from vector to raster form and vice versa (see section 3.1. below). They will also allow data reclassification. For example, a map with a large number of soil classifications can be simplified into a map with a smaller number of soil types based on the shared possession of soil qualities defined by the user as significant. Alternatively, a topographic map can easily be redefined if we seek to isolate associations between archaeological sites and particular altitude bands.

Included within these modules are procedures for redefining spatial areas of interest. One such procedure involves the definition of a "window" or a "mask" which contains an area of interest chosen from a much larger area. The window is a simple rectangular area whilst a mask is a polygon whose size and shape defines a particular area chosen for specific research needs, eg the outline of a county or state.

One of the most important aspects of processing modules are those involving the treatment of satellite images. Raw satellite images have to be processed in order to get out the information we need for analysis. This involves radiometric correction to improve the image quality, geometric correction to compensate for the curve of the Earth, compensation for irregularities in the geometry of the sensor, atmospheric refraction etc. After these corrections the image then has to be placed within a usable co-ordinate system. After all this the most difficult part is the classification of data held within the image (Hamlin 1977).

The application of these modules allows the useful incorporation of data acquired from a wide variety of sources within a well organised system which can then be used within detailed analyses.

2.2.3. Analytical modules

Analytical modules allow the manipulation of data. The majority of this work could, with enough time, be carried out with a sheet of paper and a handful of coloured pencils. For example maps

produced through the application of simple Boolean logic. These allow combinations of two or more thematic maps using logical operators; and, or and not. Simple scalar operations including adding, subtraction, division and multiplication may also be used for similar operations.

More complex are modules used in the manipulation of the Digital Elevation Model (DEM). The DEM is the digital representation of continuous changes of relief within space (Burrough 1986,39). Information generated from the DEM is of critical importance within many GIS applications and is used to produce contours and many other types of information including; intervisibility, slope, profiles, watersheds, aspect and the concavity and convexity of a surface (figure 5). A number of these techniques are used in the case studies presented later in this monograph and it is worth considering some of these modules in slightly more detail.

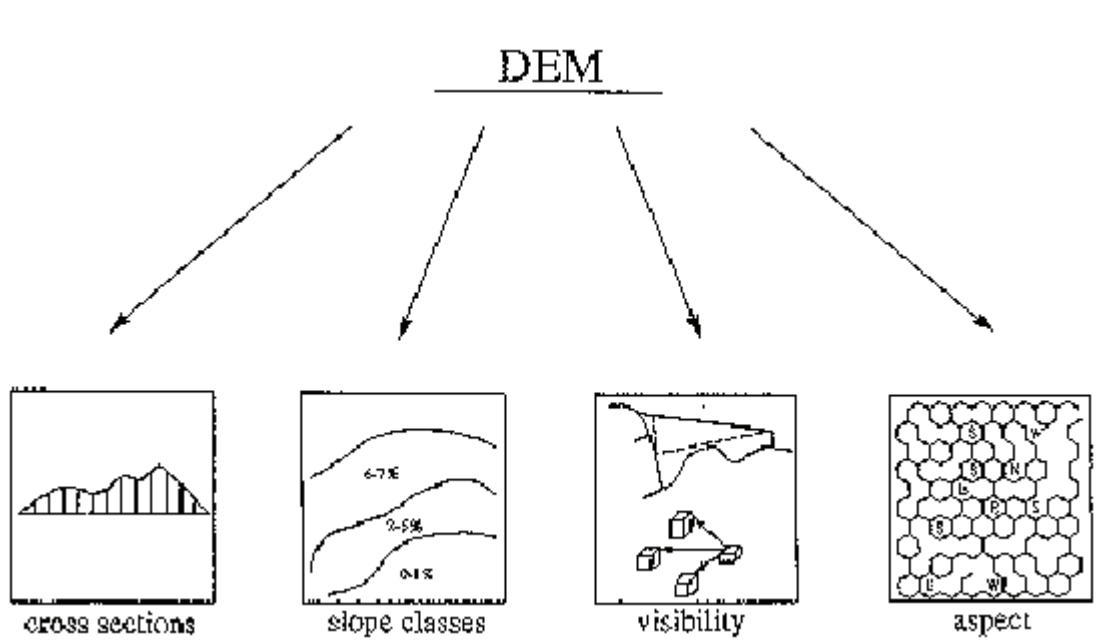

Figure 5. Examples of information derived from the Digital Elevation Model (DEM)

Intervisibility modules generate a thematic map which incorporates all areas which can be seen from a specific point. The better GIS packages allow the starting point to be defined as lying above the DEM ground surface if necessary. Within archaeology such information might be of interest to individuals studying the intervisibility of burial mounds. Slope maps carry information on user defined slope groups. This is essential information if we are studying the impact of erosion on past land use (Sheil and Chapman 1988). Aspect, often a key variable in site placement, is usually defined within 8, 16 or 24 compass segments. Watersheds are often defined as suitable archaeological study areas and can be easily provided from the DEM.

Using the DEM, GIS can calculate an optimal path between two points. This is related to the analysis of cost surfaces. A cost surface analysis defines points which can be reached with the same consumption of energy. If we assume a homogenous flat surface, points which can be reached with a similar consumption of energy will be a similar distance from the initial point. Areas of constant energy consumption will therefore be represented by a series of concentric circles. However, if the surface is not flat steeper surfaces will limit linear movement from the initial point. In its simplest form such an analysis will only be concerned with elevation, however a totally artificial surface could also be created using another variable, eg vegetation cover or soil types as the Z axis. The cost surface in such an example could then represent many factors which circumscribe man's ability to move within the environment. Results from the modules listed above can then be superimposed upon such surfaces. The last two moduls described above are often used during road planning. Within archaeology there are clear uses for such tools in the analysis and reconstruction of past communication systems, predicting the routes of water channels and the construction of hypothetical site territories, especially site catchments.

The enormous amount of information which can be derived from the DEM means that it is often the most basic and important layer held within the GIS.

Finally we should consider the role of statistical packages within GIS. Modules within such systems are usually quite simple and are mostly related to the general analysis of thematic maps, areas covered by surfaces, and the distribution of points across such surfaces etc. Complex operations such as multivariate analysis are not usually available within the system. It is therefore very important that an output module is available that allows interaction with packages that can carry out such specialist statistical functions (Farley 1987).

2.2.4. Data presentation modules

Data presentation modules control output devices forming part of the GIS. These modules enable the display of thematic maps on high resolution monitors. Apart from the data itself we also need the ability to present additional information about the map including; the legend, co-ordinates of the grid, map title etc. These have to be presented using different styles and sizes of lettering and different colours. Multiple simultaneous thematic images may also be needed perhaps to present different projections of study areas, for example to provide an orthogonal and perspective view from a defined point. Most GIS's will therefore include one or more modules for the generation of "3 dimensional" images. These modules usually allow the generation of a perspective projection based on the DEM. Whilst limited analytically such images are a popular form of data presentation, probably resulting from their similarity to the human visual concept of perspective. The image produced is familiar and comparatively easier to understand than orthogonal views.

Data presentation modules include the facility for the output of thematic maps onto paper. On the cheaper systems this usually occurs via a monochromatic matrix printer. These models also produce printouts of statistical analysis in graphical and numeric form. Better systems allow the use of plotters. The principal guide in considering these outputs is that the larger the number of outputs available, the better the system will be. All too often the use of specific printers demands that additional communication modules have to be specially written.

The complexity of the above modules is variable. Some are very simple and some very complex. However, the majority can be used on the "black box" principle. We can generally put data in and take the results out without having to understand the processes which link the two. Care, though, must be taken with some modules for which it is essential to understand the basic limitations and data demands. If these are not understood the output may be inadequate or totally wrong. Every GIS should come with adequate documentation - use it!

3. GIS DATA

The data held within GIS differs from that held in other systems because it also holds information on the spatial location and attributes of each object or point documented. Geographical data can be reduced to three basic types; point, line and area. Each of these units can be presented along with an attribute and identifying tag, a number or a name. An archaeological find would therefore be represented by an X or Y co-ordinate and a find number, whilst a road would be recorded as a string of co-ordinate pairs and its name. A forested area would be defined as a string of co-ordinates forming a polygon surrounding the area along with a descriptive name or a toponym. Each map defined by the sum of such features is composed of a group of points, lines and areas defined by their spatial position and their non-spatial attributes (Burrough 1986,13).

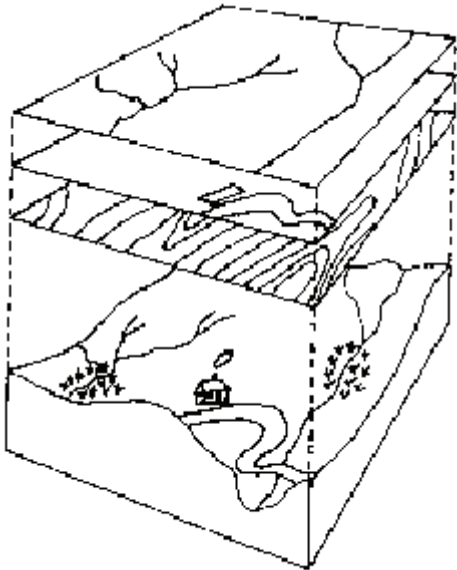

Figure 6. GIS data layers

Topographic maps represent an enormous amount of environmental data on relief, communications, hydrology etc. If we wish to transfer this to a GIS environment we must divide this information into map layers containing information on individual environmental variables. Other types of data do not always exist in the form of topographic maps eg climate, soils, and these must also be stored as separate data layers (figure 6). How then does GIS manipulate such potentially large numbers of data layers? There are two forms of organisation used in GIS - vector and raster based systems. The potential of the data for manipulation depends on the choice of data organisation and it is worth considering the characteristics of the two systems.

3.1. Vector vs. Raster GIS

Within vector based GIS all data is stored as points, lines and polygons. The aim of the polygon is to define an area by enclosing it with a continuous line. The point is defined as a co-ordinate pair and the line and polygon as a line defined by a string of co-ordinate pairs. Vector systems allow very accurate documentation of spatial data. This information is stored accurately and economically with respect to memory needs. These characteristics have resulted in vector systems often being used as the basis of network and land information systems and within high quality cartographic projects.

Raster systems, however, represent the area of interest as a series of cells connected like the squares of a chessboard. Each cell is identified through its position within the rows and columns of the grid. The point in such a system is therefore represented by a single cell, the line as a string of connecting cells and an area as a group of adjoining cells. A data layer recording

vegetation, for example, is therefore represented as a grid within which each cell contains information on the vegetation present at that point (figure 7). Difficulties occur if more than one vegetation type is present within a cell. In the example presented here, the cell has been assigned to the majority type. Raster based information is simple to store but has greater memory demands. Raster based GIS's are most suited for data groups whose edges are difficult to define or have been smoothed in some way. They are particularly suitable for the analysis of continuous surfaces such as environmental data.

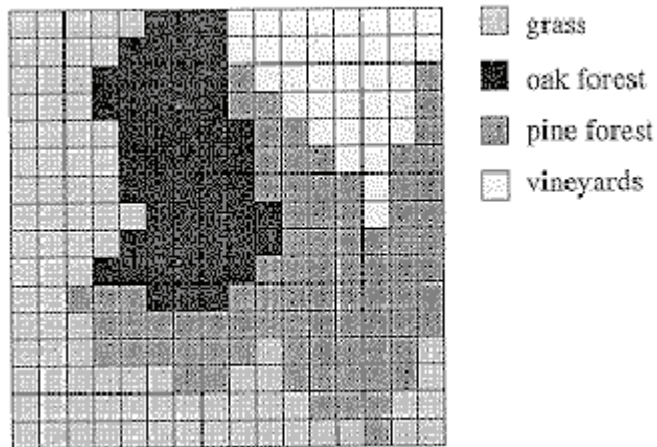
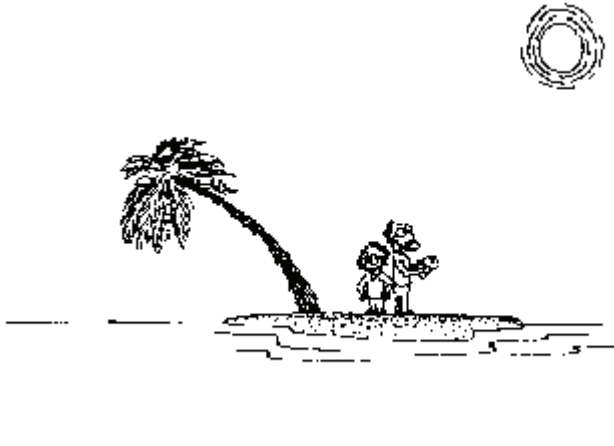

Figure 7. Raster representation of vegetation data layer

Raster systems developed from the needs of remote sensing systems and are still closely related to these systems. Vector systems, however, are more closely linked to computer aided mapping. Until recently the two systems were not compatible. Recent developments now allow most raster based systems to utilise vector based data, although analysis is still performed in raster form. We can anticipate that future developments will cause this distinction to blur or even disappear.

What then is the form most suitable for archaeological application? There is no simple answer to this question. At the regional level of analysis we are often interested in the relationship between the archaeology and the environment. The most significant point is, therefore, the manner in which environmental data is stored. In such a situation, raster systems are the preferred option. Such a choice is also suggested because of the problems associated with the collection and analysis of palaeo-environmental data. The uncertainties resulting from sampling procedures and analysis caution against attempting to provide boundaries which are more accurate than is dictated by sampling procedure. In making this assertion we are not stating that there are no specific archaeological problems which demand vector analysis, there certainly are. Intra site analysis for instance may demand the incorporation of excavated feature plans which are more likely to be in the form of vector maps.



Cartoon 2. Altitude, vegetation and slope shouldn't cause too many problems.

In considering these problems we are faced with a fundamental problem in all GIS analysis - at what level of accuracy do we have to organise a GIS system in order to carry out our analysis and what information do we wish to incorporate. Some environmental data, eg geology or soil often exists as thematic maps and some are available in digital form. Other key elements, especially the DEM, will not be available in this form. The cost of providing such information may often be prohibitive and alternative methods must be sought. The simplest solution here would be to input data manually from a topographic map where a grid of a size suitable to the nature of the investigation has been overlaid. Other alternatives could include the creation of the DEM using photogrammetric stereo pairs. Using these techniques it is possible to read in the known height of distinctive landscape features, peaks, ridges, valleys etc. and interpolate the points in between. It is also possible to use stereo satellite images and a variety of digital image processing techniques to provide the same information (Day and Muller 1988).

The importance of considering the required degree of resolution can be developed further if we hypothesise a situation in which we have chosen a raster based GIS system for an archaeological project. Here we can simplify the problem by saying that the data resolution equals the size of the raster cell. We, therefore, have to decide how large the cell should be. The cell is an indivisible unit and is therefore dependant upon the accuracy of the cartographic map used in digitisation. Such maps are usually printed with a degree of error of 0.2mm. in the map scale. An error of plus or minus 10m. on a map with a scale of 1:50,000 can be assumed if the digitiser is absolutely accurate.

Thematic maps may well be even less accurate. It is not uncommon for geological maps produced through geophysical techniques to be inaccurate at a level of plus or minus 100m. In such circumstances it would seem illogical to choose a cell resolution equal to several metres, not only because the data is unsuitable, but also because of the huge memory commitment that such a decision would demand. For instance, if we decide to use a 10 x 10m. cell size in a study area of 10km. we would have to store 1,000,000 cells. If we use only twenty map layers and each cell uses only one byte, the total memory demand is twenty megabytes. An amount comfortably stored, perhaps, on a PC, but extremely slow to manipulate on a small computer. If, alternatively, we decided that 100 x 100m. cells are adequate, the whole database can be stored within 200,000 kbytes. This amount of data can be stored and manipulated on quite a small computer. The resolution or cell size is a key point in GIS and deserves careful consideration as such decisions carry important implications on the costs of digitisation, hardware used and the speed, accuracy and value of results. Optimal cell size is not simply a question of getting results down to two decimal places, but follows from a careful consideration of research aims and the quality of available data.

A further complication for archaeologists is the use of modern natural and environmental data within GIS studies. Whilst useful in many forms of analysis of palaeo-landscapes, the availability

of large amounts of data on the modern environment may be a trap for the unwary. In an ideal world each study would come equipped with its own individual palaeo-environmental research programme. Unfortunately, this situation is rare and often we have to use modern environmental data albeit circumscribed by our limited knowledge of past environments provided through excavation and other forms of sampling.

4. GIS AND ARCHAEOLOGY

Despite many successful GIS applications in the USA (Kvamme 1989; Allen et al. 1990), there are few instances of such work in Europe (Green 1990; Madry and Crumley 1990; Wansleben 1988; Harris 1986). However, now that we have considered some of the basic principles of GIS, we may begin to consider what the technique has to offer archaeology. The first and most obvious point is the ability of GIS to handle large amounts of data. Archaeology has only just begun to fully utilise computer based spatial analysis in order to regulate data and test models. The complexity of some databases, especially those involving the integration of archaeological and environmental databases is such that work has been painfully slow or has eventually been limited to the visual analysis of simple distributions of sites across landscapes. It is invidious to criticise past approaches retrospectively, however, we can, after the example given in Goran et al. 1987, consider the case of the hypothetical archaeologist "X" who, in 1950, had been carrying out survey for the past twenty five years within a valley 10 x 10km. in area. Every single site X has found has been documented and the data stored in a card file. X knows his valley well. After twenty five years he has realised that the position of his prehistoric sites depends on natural factors, not just relief, but distance to water, soil quality, aspect and so on. He therefore started to collect data on the natural environment with the intention of creating a model of environmental change. This would then be used in conjunction with the distribution of site by period in order to investigate the effect of the environment on human activities. X, meaning serious business, considers at what level data collection should take place. Given the nature of environmental change he decides on a 10 x 10m. square - a mere 1,000,000 cells. Who is going to collect this information, where will he store it and could he finish analysing it in the finite time before his grant body pulls the plug on the finances? He considers the problems again and decides that despite the loss of some detail a resolution of 100 x 100m. will be adequate.

Having made this decision X spends a sleepless night trying to decide which data he should collect and which might be important for sites of all periods. Altitude, relief vegetation, slope..., all have to be considered. Twenty data types are eventually chosen. Twenty variables for 10,000 cells. The next morning, pencil and paper suggests that a fully trained team working for a year might finish collecting the data. A further glance at the project finances convinces him that the whole concept was a beer induced fantasy and he quickly forgets it.



Cartoon 3. Information on cell 1282045? Yes I think we've got it here somewhere.

A few decades later and we can carry out everything that X wanted with relative ease. Satellites provide a cheap and easy vehicle for data acquisition, much of which has already been converted into thematic maps. Huge quantities of data can now be stored on computers which can carry out analyses which previously took years in a fraction of the time. Virtually all of this can now be carried out using geographical information systems.

One other vitally important aspect of the development of GIS is the freedom it has given archaeologists to move away from the artificial confines of the archaeological site and to consider of the wider aspects of settlement studies. In the past much site location analysis has proceeded along the lines of a study of the physical attributes of the site itself. Those attributes which were physically present were then judged as central to the placement of the site. For example, the distance of a site to water or the amount of arable land within a site catchment. However, we have often missed the negative side of such arguments. We have rarely been able to handle information on situations without sites and a similar distance to water or where there is a similar amount, or even more, arable land but no site. The result has been a situation in which we are unable to judge the real value of specific attributes to site location. Our failure to look at the other side of the coin is largely the result of our past inability to handle the very large amounts of information demanded by such studies (Kvamme 1985). These situations demand that we either study a random sample of points throughout a study area or, we would suggest, analyse the environment of sites and non-sites through GIS.

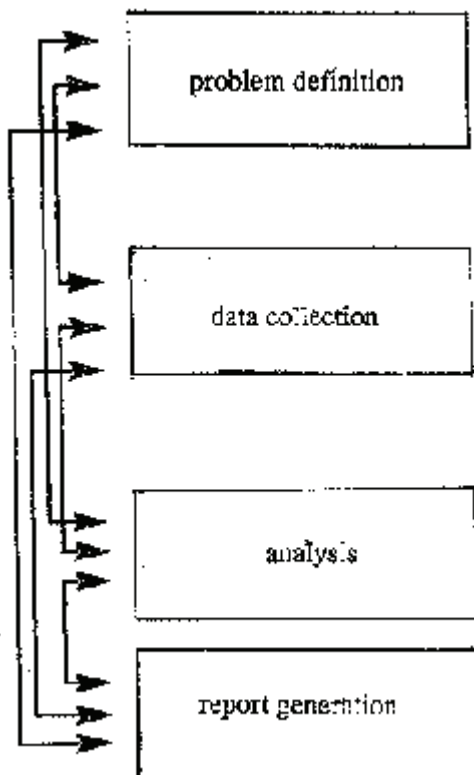

Figure 8. Flow chart representing GIS information paths

If the introduction of GIS into archaeology is as important as we believe it is, how should we use the techniques practically? We have already seen that GIS should be viewed as a tool to manipulate spatial data. Archaeological spatial data may be viewed at a number of different levels (Williams et al. 1990). At the macro level we might study the distribution of cultural groups or trade networks across Central Europe. Below this we are interested in the analysis of space within a political/socio-economic boundary or a settlement pattern within a region. At the lowest level we would probably like to investigate the site and the spatial analysis of objects within a site. As we have discussed already, each of these levels demands a different level of data resolution. Resolutions of 1km. plus will be more normal when investigating cultural phenomena and

centimetres when dealing with intra-site analysis. However, whilst the data in such studies varies, the tools used by GIS to analyse them are essentially the same

The specific nature of individual problems within GIS analyses as in other mathematical models, demands a structured approach comprising of: problem definition, data acquisition, data manipulation and report generation (Ressler 1989). The process is not linear (figure 8). Earlier phases may need to be reviewed in the light of results and further data sought if necessary. Even the original questions may be redefined at a later date, if not with impunity then, given the nature of GIS, with relative ease. A situation which could not have been entertained prior to the development of GIS techniques.

Given the flexibility of the technique, the list of applications is almost limitless. Some of the permutations of regional analysis will be explored in the following chapters devoted to data from the island of Hvar. However, further examples can be found elsewhere in the literature (Allen et al. 1990), along with applications in intra-site analysis (Gill and Howes 1985), and cultural heritage management (Parker 1986; Altschul 1990). Apart from the width of applications, published examples indicate that after the first successful experience with GIS, many archaeologists will find it difficult to imagine serious work without access to such techniques (Peregrine 1988).

5. CHOOSING A GEOGRAPHICAL INFORMATION SYSTEM

Having, hopefully, convinced some of our readers to apply GIS within their specialist fields, the choice has to be made of a suitable system. A number of publications provide reviews of available hardware and software and there is no need to repeat such detailed information here (The American Farmland Trust 1985; Eastman 1988; Parker 1989), nor to discuss the problems of the organisation of such systems (Burrough 1986; Meckley 1987; McRae 1989). Rather, we feel that it would be of more use to consider some of the initial problems faced by an individual or group setting up a system

The price of GIS software can vary from a free public domain package to commercial systems costing tens, or even hundreds of thousand of U.S. Dollars. Price, however, does not guarantee that the system is suitable for the user. At the lower end of the market a number of systems are available that can be run on PC's and which require basic hardware, a small hard disk and a cheap digitiser. Output can be achieved through an ordinary dot matrix printer. These systems are not commercially oriented and are often the product of research by universities. These systems may cost as little as a few hundred U.S. Dollars and the hardware may impose severe limitations but may still be compared with their bigger brothers with whom they may have excellent communications, facilitating easy exchange of information for more complex analysis.

A larger project will, quite naturally, create greater demands on the GIS and considerable thought must be given to the system before any purchase is made. Apart from academic considerations, care must be taken concerning the support provided by the software for specific hardware configurations, the existence of a suitable customer support and training service. It is often advisable to look at systems which come from reliable companies working with government agencies or established educational institutions, as these software projects are more likely to continue and develop. The organisation of the hardware is critical within large projects and will involve considerable expenditure. At this level you should anticipate the use of graphic workstations with a large storage capacity and with tape drives. Such a hardware configuration will also support the better quality data input and output devices.

6. GIS SOFTWARE AND HARDWARE USED IN THE CASE STUDY

The pilot study presented in this monograph was carried out using equipment belonging to the Arkansas Archaeological Survey (AAS) at the University of Arkansas (Fayetteville). The AAS has been involved in the development of new analytical methods within archaeology for a number of years and, since 1986, has been active in the application of GIS within archaeological research and data management. The GIS system used by the AAS and which was made available for this work is the Geographical Resources Analysis Support System (GRASS).

GRASS was designed as a high performance interactive environment for geographic data management, analysis and display. It was originally created for the U.S. Army and was intended to be applied in land management programs associated with military installations. Its primary aim is to allow the optimal use of available training areas and ranges, to maintain land in a manner suitable for long term military use whilst protecting valuable natural and cultural resources and accommodating secondary land uses including forestry, grazing, hunting and recreation (Lozar and Goran 1987).

The origins of GRASS lie in the use of raster based software in the analysis of the Fort Hood area in Texas (Westervelt 1988). GRASS itself, however, has only been available since 1986 and is still undergoing development. Despite this the software has now been released into the public domain and it can now be obtained without cost from the Army Corps of Engineers, Construction Engineering Research Laboratory and a number of associated federal agencies. A negative side of many other public domain softwares is that they suffer from poor documentation and a lack of consistent development funding, training opportunities and system support. However, this is offset in the case of GRASS by the fact that the number of users within the U.S. establishment virtually ensures continuing development of the system and the fact that some private companies and universities are now distributing GRASS commercially and will assist with training and installation of the system.

GRASS is a UNIX based software written in C. It is distributed in source code and is currently running on a number of different workstations including; Sun, Concurrent, Intergraph, Apple Macintosh, PC386 and 486's, HP9000, AT&T 3B2, DEC, and IBM 6000. It has recently been released in the X-Windows environment increasing its portability to any machine running under such an environment (Gardels 1988; Westervelt 1990). GRASS is a raster based GIS which allows the user to manipulate, analyse and display data, and output data as colour images or in tabular statistical form. GRASS allows digitisation of data layers manually through a digitising table or alternatively to input data in digital format either as a DEM, digitised aerial photographs or satellite data including SPOT or LANDSAT. Inputted images can be processed using a variety of filters, geo-referenced and information extracted via multispectral classification (Madry 1989). GRASS contains modules for the analysis of watersheds, drainage networks, visibility analyses and least cost surfaces and paths. Boolean and weighted analyses can be carried out along with distance measurements from points, lines and polygons. Powerful modules for univariate statistics are also included within GRASS. Modules exist allowing GRASS to communicate with other GIS packages, however, the integration of GRASS with some specific database management systems and statistical packages allows the retrieval and interactive manipulation of data from relational databases and the performance of sophisticated multivariate analysis (Farley 1989; Parker 1989)

Several different hardware platforms were used during the study. A Compaq 386 PC with Altec digitiser was used for data input whilst Masscomp and Concurrent machines with larger monitors and greater resolution were used for analysis. Inkjet and thermal printers provided hardcopy output. The performance of GRASS on these different units was essentially the same, the only difference occurring as a result of the mass storage units and the processing speed. In this respect the older Masscomp was a relatively poor performer. Given the resolution of the raster data, nearly 4,000,000 20 x 20m. cells per data layer, greater speed of the newer machines was of great value.

We should put on record the fact that we found the software surprisingly easy to use. Each GRASS module could be approached from several routes. For the beginner, the easiest path is via a series of pull down menus, whilst a more experienced user can use interactive commands to proceed through an analysis. In the latter path, whenever a module is initiated, a series of questions will prompt for information necessary for the completion of the exercise. The advanced GRASS user can execute modules via direct command lines. The software design allows each user to adopt the execution mode most appropriate to their knowledge of the system.

All in all we were most satisfied by the performance of the system and emerged with the distinct feeling that GRASS was the correct choice of software for our particular applications. However, do remember, different applications require different solutions. GRASS is simply one possible option amongst available raster based GIS and image processing systems.

SECTION TWO: THE HVAR CASE STUDY

1. THE STUDY AREA

The area chosen as the subject of this pilot study was the island of Hvar in Dalmatia, Yugoslavia (figure 9). At the nearest point the island lies only 4km. from the mainland. It is c. 68 km. long and nowhere exceeds 15km. in width. The long, narrow shape of the island is dominated by a high mountainous spine which is topped over the most part by a bevelled plain at c. 300m. but rises to 626m. at the highest peak named Sv. Nikola. The coastline is precipitous but the northern central section is dominated by the low, fertile Stari Grad plain.

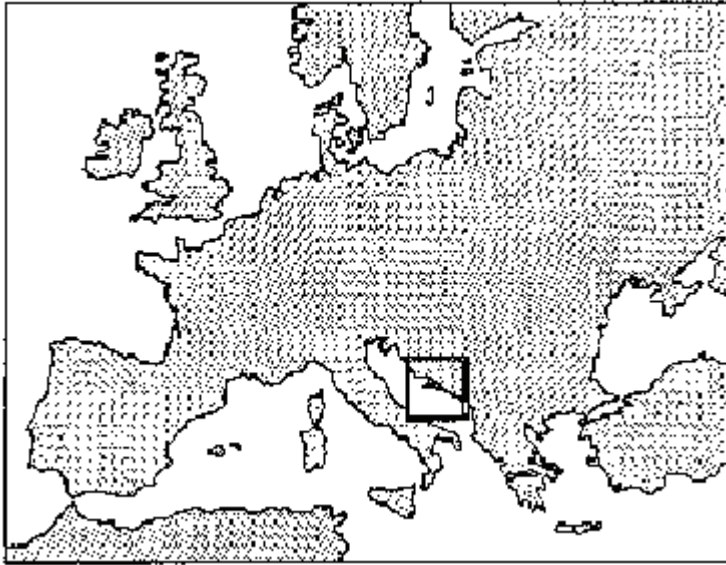

Figure 9. Location of the island of Hvar within Europe.

The dominant limestone geology of the island has produced typical karst scenery. Steep slopes and caves abound and the soils are generally terra rossa variants which can vary dramatically in depth. The Mediterranean vegetation of the island also reflects Hvar's geology. The peaks and steepest slopes are largely bare, with pine forests covering the lower slopes. Large areas of land are now covered with secondary scrub. Elsewhere olives, vines, lavender and rosemary dominate the scenery.

The climate of Hvar is particularly pleasant and the population of the island is now largely devoted to catering for the tourists that flock here during the summer months. The island averages 2711 hours of sun annually and averages only three days of frost per year. Rainfall, varying between 741mm. (Hvar town) and 1022mm. (Zastrazisce) annually falls mainly between October and April.

The island has a population of c. 11,000 people, the majority of whom are found in three coastal settlements; Hvar, Stari Grad and Jelsa. Most of the population are directly or indirectly involved in the tourist industry. Traditional agricultural and industrial pursuits are in a steep decline and the settlements associated with these activities in the interior of the island are rapidly becoming depopulated.

2. THE ENVIRONMENTAL DATA BASE

Despite the increasing awareness in Yugoslavia of the importance of environmental data to archaeology, their study is still at an early stage. Consequently, very little information on the palaeo-environment of Dalmatia is currently available and no significant data is obtainable for the island of Hvar specifically. However, we were fortunate that the island had recently been the subject of a major developmental plan study. This study included reappraisals of all the major contemporary environmental variables relating to the island. Given the lack of palaeo-environmental data, and despite the dangers of using information relating to the modern environment, we decided to use this data as variables for input into the GIS study.

A pixel resolution of 20 x 20m. was chosen for use within the case study. This meant that Hvar, the small islands close by and the surrounding areas of sea were covered by a grid of 3,800,000 pixels. Four variables were chosen for incorporation into the pilot study. These were;

- Digital Elevation Model
- Soils
- Lithology
- Micro-climate

2.1. Digital Elevation Model (DEM)

The DEM (figure 10) was derived from a topographic map of Hvar at the scale of 1:50,000. Contours with an interval of 20m. were digitised and some additional characteristic features added eg peaks, ridges etc. Altogether more than 11,000 points were collected. Given the chosen resolution, and the fact that the data was collected with a precision of plus or minus 10m., this number of points should have been sufficient for the derivation of a DEM. However, serious problems were encountered. After 120 hours of continuous calculation, the computer could not interpolate the DEM using the most suitable algorithm. Therefore, another algorithm was used. This was less satisfactory as it produced a stepped surface which had to be smoothed separately (Kvamme 1990). This decreased the vertical accuracy of the DEM to plus or minus 30m. although the basic horizontal grid remained unchanged.

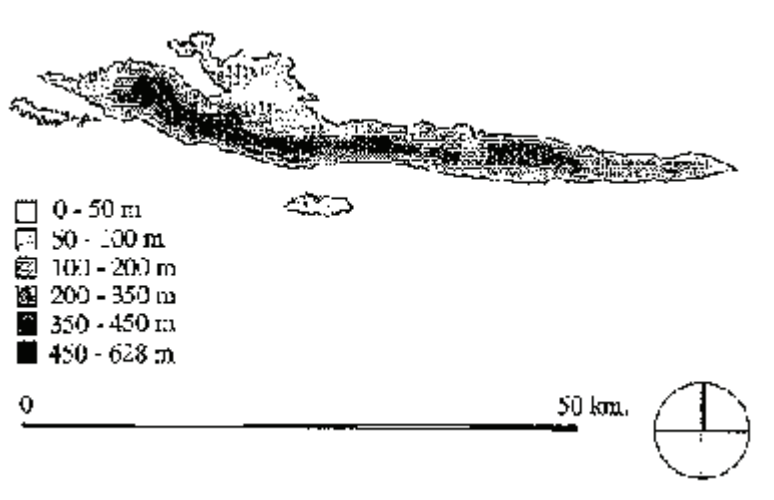

Figure 10. The Hvar DEM

Some care must be expressed in using the data derived from this information. There has been significant landscape change in the Adriatic basin since the late pleistocene when the sea level of the proto-adriatic may have been 150m. lower than it is today (Chapman 1981). Consequently we must expect to have lost not only palaeolithic and mesolithic settlement sites as a result of these changes, but also significant amounts of economic and social territories associated with early sites that have survived. In the future, as more refined data becomes available some degree of reconstruction of earlier shore levels and associated territories should be possible using GIS techniques. For the purposes of this analysis, however, the data provided from the DEM is

likely to be significant for most of the periods under study and we can proceed with some degree of confidence in the relevance of the results.

2.2. Soils

The detailed soil map (Colak 1955; Bogunovic and Smanjak 1984) made available for analysis within this study contained no less than twenty five soil groups classified according to their chemical and physical properties, depth, and agricultural potential. This map was digitised using a coordinate digitiser with an accuracy of plus or minus 10m. After editing, the data was transferred from vector to raster form with a basic resolution of 20 x 20m. It was considered that this classification was too detailed for archaeological purposes and the map was reclassified on the basis of agricultural potential. Four land potential classes were produced through this procedure and the results are shown in figure 11 and the relative percentage of each class is shown as a pie chart in figure 12.



Figure 11. Simplified soil map based on agricultural potential

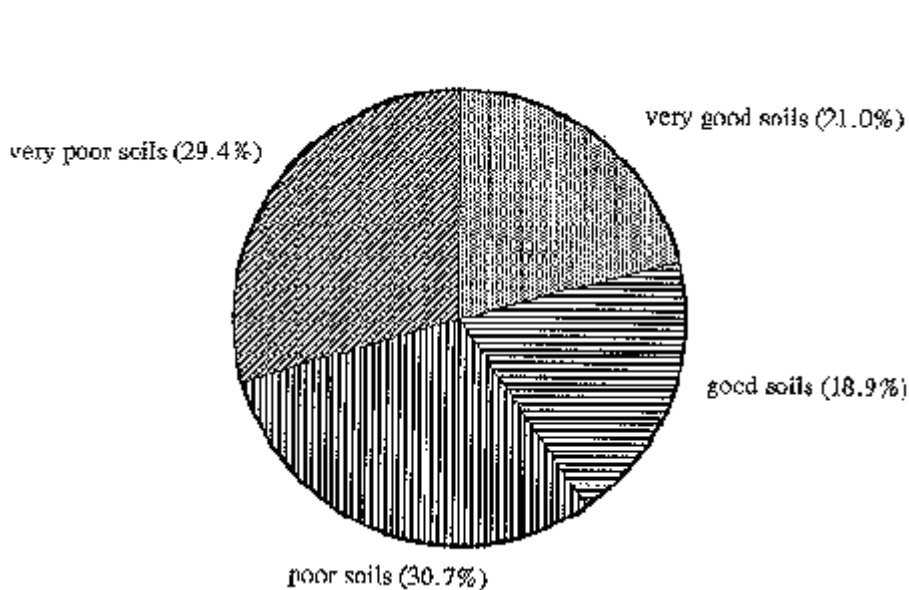

Figure 12. Pie chart illustrating soil classes on the island of Hvar

Once again we must stress caution in the use of such data for archaeological research. The soils of the karst are disturbingly fragile and prone to erosion. Significant changes can occur within karst soils during very short periods of time, and change over the period covered by this study has undoubtedly been dramatic (Shiel and Chapman 1988). Many areas which now have limited agricultural potential must have been more attractive to human use in the past, and some areas which may not have been so useful eg seasonally flooded valley bottoms, may now have been modified to form attractive agricultural zone. Once again we can suggest that future GIS research will be able isolate these areas, and indicate which zones were susceptible to erosion and pedological change in the past, thus allowing an attempt at detailed environmental reconstruction. For the purposes of this study, however, we are reliant upon contemporary data and the belief

that the soils which are considered useful today also played a significant role in earlier agriculture regimes.

2.3. Lithology

Lithology (figure 13) is undoubtedly the most stable of environmental factors used in the study of Hvar. The basic solid geology of the island has remained unchanged throughout the period under study (Herak et al. 1976). The island is dominated by a core of dolomite and limestone laid down during the cretaceous, overthrust and raised during later orogenies. The archaeologically important flysch deposits on the southern side of the island are eocene in date whilst quaternary deposits including alluvium and colluvium are restricted, mainly to Stari Grad plain and the narrow coastal valleys. The relative percentage of lithology groups for the whole island is shown in figure 14. The data was digitised from a thematic map at a scale of 1:50,000 and consequently we were able to achieve the resolution desired for the environmental data. However, it must be emphasised that the source of the thematic map was the state geological map which was at the scale of 1:100,000.

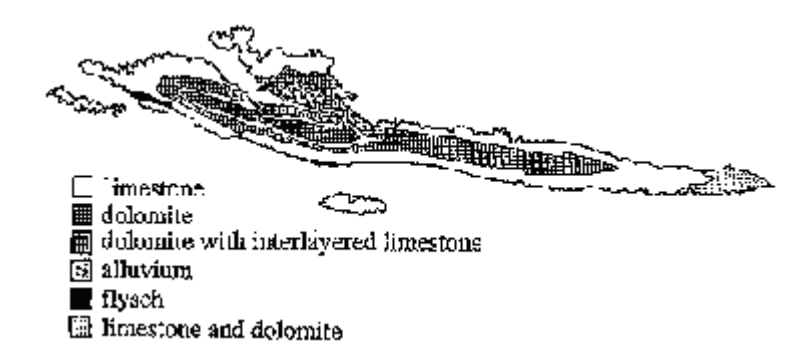

Figure 13. Lithological map of Hvar

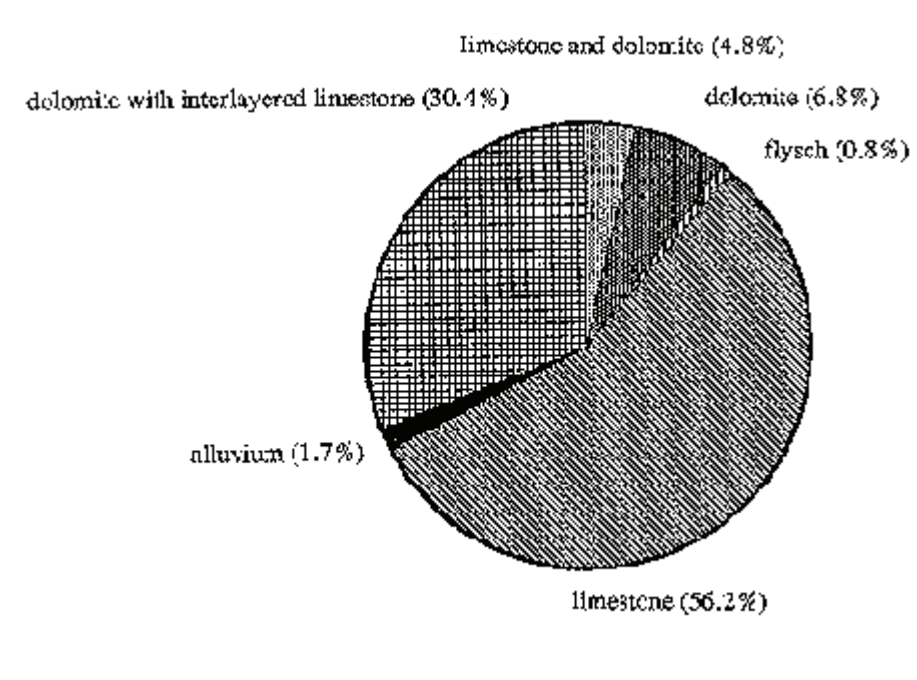

Figure 14. Pie chart illustrating lithology classes on the island of Hvar

2.4. The Micro-climate

Data on the micro climate of Hvar is derived from a relatively limited number of samples and incorporates data relating to insolation, rainfall and wind (Makjanic and Volaric 1979). This information has been analysed to provide information on the relative qualities of micro-climates

across the island (figure 15). Although the climatological data was also stored in pixels of 20 x 20m., it must be emphasised that because of the nature of the sampling strategy, the achieved accuracy could be estimated as plus or minus 1km.

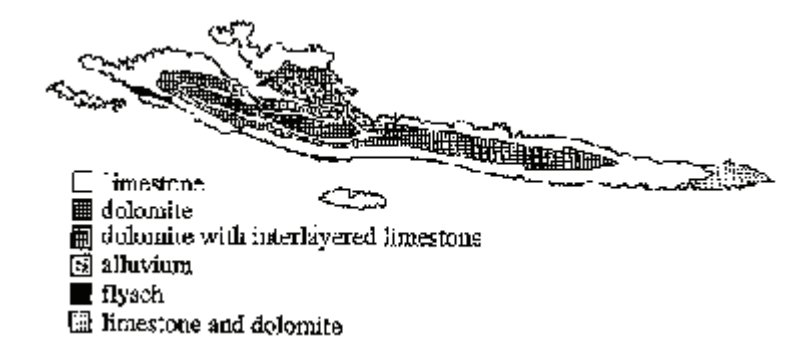

Figure 15. Microclimate zones

Hvar has a relatively long history of climatological research. Grgur Bucic (1829-1911), an important early antiquarian on the island was also a keen meteorologist (Tadic 1978). Unfortunately, this data cannot be extrapolated back with confidence. Despite this the relative attractions of large parts of the island, eg the area of Hvar town on the south coast as opposed to the town of Jelsa on the central northern part of the island, during specific periods are worth investigating using this data as a guide. Within the study presented here climate data was only applied to the most recent period under study, the Roman period, in an attempt to use GIS to gauge the relative value of soil quality and climate to Roman agriculture.

3. THE HVAR ARCHAEOLOGICAL DATABASE

This monograph is not the place to present a history of archaeological research on the Island of Hvar nor attempt to provide an authoritative description of the archaeology of the island. However, it is essential to briefly describe the basic chronology of the archaeological remains on the island and acknowledge the considerable amount of past archaeological research which has been carried out. Cumulatively, it is the work of past and present archaeologists on the island that has provided a database capable of responding to the considerable demands of GIS techniques.

3.1. Previous Archaeological Work on Hvar

Modern archaeology on the island of Hvar began during the nineteenth century with the work of Peter Nisiteo (Nikolanci 1977). Nisiteo's work on classical antiquities was carried on during the nineteenth and early twentieth century by a number of distinguished academics and antiquaries, perhaps the most well known of which were Sime Ljubic and Don Frane Bulic, the famous director of the Archaeological Museum in Split (VAHD 1986).

DATE	PERIOD	PRINCIPAL SITE
7-800	The arrival of the Slavs? Decline of the power of Rome, Hvar ruled by	Late Roman fortifications at Grad,
6-700	Byzantium	Jelsa
A.D.		
0	Domination by Rome Roman Pharia	
B.C.		
385/4	Greek colony founded at Stari Grad	Greek Pharos Full development of the hillfort system. Hvar Castle
1000	The Iron Age	
		The first hillforts. Burials within tumuli. The barrow cemetery at Vira.
2000	The Bronze Age	
2500	The Eneolithic	
		Cave sites at Markova and Grabceva spilja
	The Neolithic Hvar Culture Danilo Impressed ware	
7000		
	The Mesolithic	?

Table 1: Chronological table for the Island of Hvar

Work on the important prehistoric remains on the island began slightly later than that on the Classical and later antiquities. Despite this the work of Grgur Bucic during the mid-nineteenth century on sites including the prehistoric caves; Markova spilja, Grabceva spilja and Sveta Nedjelja demonstrated the importance of the remains on the island. This was rapidly followed by a large number of cave and tumuli excavations by Ivan Krstitelj Novak, M.E. Weisser, Sime Ljubic and others (Petric 1979).

Throughout most of the twentieth century, Hvar archaeology has been dominated by the work of one man - Grga Novak. Novak who was born on the island was one of the most influential archaeologists in Yugoslavia eventually becoming President of the Yugoslav Academy of Arts and Sciences. He wrote copiously on the history of the island and led a series of important archaeological excavations on sites of many periods (Novak 1972). His most significant work was the excavation of a series of caves on the island and the definition of the late Neolithic Hvar Culture (Novak 1955). The results of the work of these and other archaeologists has given us a relatively clear idea of the chronology of archaeological settlement on the island (table 1).

3.2. An outline of the Archaeology of Hvar

3.2.1. The Neolithic (figure 16)

Grga Novak's publications of the painted pottery of the later Neolithic Hvar culture brought the attention of many archaeologists to the island of Hvar. The distinctive and rather beautiful pottery of the later Neolithic tends to distract attention from the evidence for earlier settlement on the island. Finds of impressed ware sherds from a number of cave sites on the island indicate that man was living on the island c.7,000 years ago. Although we assume that these early settlers were farmers we have little direct evidence for their lifestyle on the island. What little we know has been provided from the excavation of the two cave sites of Grabceva and Markova spilja (Novak 1955, 1959a) Apart from the archaeological deposits in caves we have very little other settlement evidence other than chance finds relating to this period. Presumably this reflects the loss of sites over the very long period of time and the lack of fieldwork.



Figure 16. Neolithic findspots on the island of Hvar

3.2.2. The Bronze Age (figure 17)

During the Bronze Age there is increasing evidence for human settlement on the island. A number of hilltop sites with bronze age pottery are located across the island, several of which are very large and some at least must have been equipped with defences.



Figure 17. Bronze Age findspots on the island of Hvar

Burials under mounds of stones gathered from the fields became common practice for a portion of the population during this period (Petric 1975; Marovic 1985). Within these tumuli the most frequent burial practice is that of a crouched burial within a rectangular stone cist. Although some of these mounds achieve massive proportions, up to four metres high and thirty metres in diameter, grave goods tend to be relatively poor and restricted to pottery and occasional metal and stone objects. This burial practice survives throughout the Bronze and Iron age. One example on the Pakleni Islands contained Hellenistic pottery and a fibula of the first century B.C. (Novak 1959b).

These mounds number hundreds throughout the island as isolated examples or in groups several of which may be classified as cemeteries. The largest group is that surrounding the bay at Vira in the western part of the island. These twenty two mounds centre on a distinctive peninsular

containing a single mound (Zaninovic 1978b). The largest of the tumuli in this cemetery is a double mound measuring thirty four and a half metres along the longest axis and three metres high.

3.2.3. The Iron Age (figure 18)

There is evidence for the emergence of a settlement hierarchy during the Iron Age. A series of defended enclosures dating to this period have been found. There is a wide variety of size within these sites. Some are represented by little more than a small wall sealing off a ridge and could never have contained more than a handful of huts, whilst others are very large with massive ramparts and might have contained significant numbers of people. The Castle site above Hvar, which is associated with the large barrow cemetery at Vira, appears to be in a position of pre-eminence in the western part of the island at least. Apullian pottery from this site indicates the incorporation of the island within long distance trade networks from the eighth century B.C. onwards (Petric 1986).



Figure 18. Iron Age findspots on the island of Hvar

3.2.4. The Greek Period (figure 19)

The Greeks were becoming increasingly interested in the Adriatic from the eighth/seventh centuries B.C. onwards (Batovic 1984). Presumably, the Greeks were attracted to this area initially by the prospect of trade with the peoples who inhabited the islands and the shores of the Eastern Adriatic. Trade turned to settlement in 385/4 B.C. when we learn from the first century historian Diodorus Siculus that the Parian Greeks decided (on the advice of an oracle) to found a colony on the island of Hvar. Despite friendly relations at the beginning of the colonising venture, the natives attacked the colony with the help of allies from the mainland. The colony only managed to survive with the help of the fleet of Dionysius of Syracuse which arrived, like the cavalry, just in time to save the colonists.



Figure 19. Greek findspots on the island of Hvar

The remains of this colony, which was known as Pharos, can still be seen on the site of the modern town of Stari Grad on the western edge of the large plain on the Northern half of the island. Some sections of its defensive wall still stand to several metres in height whilst excavation on the site has provided traces of Classical and Hellenistic houses (Kovacic 1989). The colony is associated with a massive field system which appears to have been laid out in a single phase (Stančič and Slapsak 1988). The traces of these fields stretch across the Stari Grad plain from Stari Grad in the West to Vrboska in the East and cover an area of c. twelve square kilometres. The boundaries of the fields have been preserved in massive field walls constructed from stones collected during field clearance and it is one of the best preserved examples of such a field system. The town of Pharos and its territory were protected at one point by a pair of large stone towers at Maslinovik (Kirigin and Popovic 1988) and Tor (Zaninovi 1982). Whilst the tower of Maslinovik has suffered extensive damage, that of Tor has suffered less, presumably because of its isolated position high above the plain of Jelsa.

3.2.5. The Roman Period (figure 20)

The history of the Greek colony at Pharos is a complex tale of the relationship of the colonists, the native Illyrian population and the eventual rise of Rome to a position of hegemony within the Adriatic during the second and first centuries before Christ. The date of the formal incorporation of the island within the Roman Empire is not known although de facto rule must have occurred by the middle first century B.C. at the latest. The results of Roman rule are obvious. There is a massive increase in the evidence for occupation across the whole island. The town of Pharos expanded in area dramatically, there is an enormous amount of evidence for an increase in agricultural activities. The remains of Roman farms (villas), cisterns for water collection, farm estate walls and in some cases small harbours for the use of villas occur in virtually every part of the island. The size of farms varies from small and relatively humble farmsteads to luxury complexes covering very large areas. Excavation of one of these sites at Kupinovic on the Stari Grad plain has revealed part of the working area of a farm with its systems of presses and stone vats used to produce olive oil or wine (Zaninovic 1987).



Figure 20. Roman findspots on the island of Hvar

Although the increasing instability of the Roman Empire during the sixth and seventh centuries created havoc within the Roman province of Dalmatia, the cities on the coast were protected for some time from attack by the mountains which run parallel to the coastline. It is also likely that the Dalmatian islands, including Hvar, acted as havens for refugees fleeing the troubles on the mainland. Evidence for these troubled times may be found in the defended site at Grad, Jelsa where a large wall seals off a small peninsular. This site may be part of a series of late Roman fortifications along the coast of the Eastern Adriatic, built to secure the strategic shipping routes along the coast to Northern Italy.

3.2.6. The Post Roman Period

The chaos of the region during the seventh and eighth centuries prevents us knowing when the Slavs arrived on the island (Evans 1989). The uncertainty of the period is reflected in the dramatic change in the island settlement pattern during this period. During the Roman period isolated habitations were scattered throughout the island. By the Medieval period the population was gathered in villages set away from the coast for safety. The island passed through a number of hands in the post Roman period, Byzantine, Hungarian, Croatian, eventually becoming a Venetian possession in 1420. The prosperity of the Venetian period is reflected in the growth of the modern town of Hvar with its many handsome buildings, castle and cathedral and the gradual establishment of villages on the coastline. The Napoleonic war ended Venetian rule of the island which passed to France (1805-1812) and then to Austro-Hungary. After a brief Italian occupation (1918-1922), the island became part of the Kingdom of the Serbs, Croats and Slovenes, the precursor of the modern Yugoslav state.

3.3. The Archaeological Database

Apart from the labours of those Hvar archaeologists mentioned above, the recent rationalisation of all the available information on the archaeology of the island of Hvar has followed from the work of a number of institutions and individuals. Between 1981 and 1986, the Museum of Split, the University of Ljubljana and the Institute of Archaeology, Belgrade were active on the island surveying known antiquities and collating information (Kirigin and Slapsak 1987). From 1987 an enlarged team was created to begin systematic survey on the Island. Further participants in the project included the University of Bradford and the Royal Ontario Museum (Bintliff and Gaffney 1988).

Using this earlier work as a basis, a complete survey of known archaeological monuments was undertaken between 1988-1989. This survey was intended to provide standardised information on every monument on the island dating from the prehistoric and Roman periods in order to provide a Sites and Monuments Register for the entire island. Whilst it would have been desirable to attempt to register sites of all periods, the practical problems of achieving this within a year prevented such an approach. However sites of more recent date were recorded in the field if they were previously unrecorded or there was evidence of serious damage or threat to the monuments.

The provision of this register was intended to allow a quantitative assessment of the nature of sites, their environmental setting and state of preservation. Detailed information on data held within the database is given in the Appendix. During the year that it took to compile this information all the locatable archaeological monuments on the island were visited and all available information on them collated. Drawings and photographs of surviving remains were made wherever possible. The effort involved in such a survey was considerable. Karst countryside is one of the most difficult of terrains in which to work. Work within this terrain has been made even more difficult as the result of the depopulation of the centre of the island within recent years. Many parts of the island are no longer cultivated and a large number of sites are now lost inside almost impenetrable forest and maquis. Even a short walk across this countryside can take hours and risk serious injury.

All this information was inputted into a database using FOXBASE+ version 2.00 as the database environment and held on a IBM compatible PC. The information held within the database was considerable, holding 756 files totalling 2.7 megabytes of memory. The sites and monuments data forms a part of a much larger database now being inputted which will eventually contain information on the spatial distribution of all pottery collected between 1981-1989 and the full bibliographic details for the archaeology of the island.

4. GIS APPROACHES TO THE ARCHAEOLOGY OF HVAR

The information held within the archaeological database can be considered as a map layer, and treated in much the same way as the environmental data. Selected information was output, ported to the GIS workstation and stored as point data.

In a short monograph there is no possibility that we can attempt to consider the archaeology of Hvar as a whole, nor given the number of other specialists working on the subject would it be particularly useful. What we can do is try to investigate some specific areas of the archaeology of Hvar through the application of GIS techniques. By doing this we would hope that we could show other interested archaeologists how such software can approach traditional types of research and where they open new analytical possibilities. It should be emphasised that the separate problem oriented case studies presented below do not represent the limit of GIS within archaeology. We would need considerably more space than is available to us simply to present the limitations of GIS with respect to the data we used in the case study. The almost unbounded variability of archaeological, topographical and environmental situations throughout the world further prevents any attempt at an authoritative statement on the limitations of GIS within archaeological analysis.

We would also like to use the case studies to illustrate the type and resolution of data archaeologists working in Yugoslavia and elsewhere must collect if they are to make good use of the potential of GIS. As we will show, the data from Hvar, which is probably one of the better corpuses of regional data from Yugoslavia still provides considerable difficulties during GIS analysis largely resulting from gaps within the data and lack of access to particular types of information, especially aerial photographs. However by presenting the case studies "warts and all" we can help other archaeologists sidestep some of our own problems.

Following this line of thought we have restricted ourselves to three particular problem areas;

- 1) The definition of site territories.
- 2) Aspects of the analysis of land use within site territories.
- 3) Factors affecting the location of sites

These three areas of research are fundamental to most forms of landscape analysis and none is specific to any particular archaeological period. Where people lived, why they chose to live there and what their relationship was with the surrounding area are questions that most archaeologists ask and in using GIS to tackle these basic problems we can demonstrate to the reader the potential use of such techniques in their own areas of research.

5. GIS APPROACHES TO TERRITORIAL BOUNDARY DEFINITION

Virtually all human groups produce boundaries and the history of archaeological research is littered with attempts to locate these problematic barriers (De Atley and Findlow 1984). Cultural boundaries, ethnic boundaries, property boundaries and the less tangible boundaries of personal space have all become the object of archaeological research at some point or another and a bewildering range of archaeological examples and ethnographic cautionary tales relating to their definition can be found in the literature. Despite the perpetual dangers of "drawing lines that don't exist around areas that don't matter", in this chapter we intend to look at one very traditional form of boundary analysis, site catchment analysis (SCA) and consider how GIS can be applied to the problems of boundary identification.

SCA has a long pedigree in archaeology having been introduced twenty years ago by Claudio Vita-Finzi and Eric Higgs (1970) and does not need more than the briefest of introductions. It is essentially quite a simple concept. The basic tenets of site catchment analysis are that restrictions on energy investment and economic return demand that the further an area is from a settlement the less likely it is to be used and that eventually the point will be reached at which land will be uneconomic to maintain - an economic boundary will therefore be expected at this point. Ethnographic studies indicate that this boundary will vary between more mobile societies such as Hunter-gatherers and sedentary farming groups. Generalised boundaries of 10 and 5 km. are often suggested for these types of society respectively. The circular catchments produced from such studies are often re-analysed to compensate for walking time, only those areas within the time allocated for a 5 or 10 km. walk being included. Having established the catchment, the land within it can then be analysed for clues to the potential of the land and indications for the function of the site. The concentric circle diagrams that are the hallmark of studies guided by these principles have sometimes been criticised as simplistic. However, the foundations of the theory remain valid and when thoughtfully applied they can produce useful results.

The application of SCA through GIS is a relatively easy procedure and can be demonstrated through the analysis of hillfort sites on the island of Hvar. These Iron Age/Bronze Age settlement sites are situated on hilltops and surrounded by stone ramparts which can achieve massive proportions. As noted in the introduction to the archaeology of Hvar there appears to be a hierarchy of these sites. The majority of sites can be classified as lower ranking settlements which amount to little more than a wall defending a small hilltop spur and where a few huts can be built with some degree of security. However, a small group of sites stand apart from the majority by virtue of their size, and these presumably represent the top of the settlement hierarchy. These hillforts could have accommodated considerably larger numbers of inhabitants than any of the other sites and their defences indicate a greater control and investment of labour. We can assume that these sites functioned as some form of central place. Given the distinct role of these larger sites we felt that it would be more useful to analyse them as a group rather than attempt to investigate the entire range of hilltop defended enclosures.

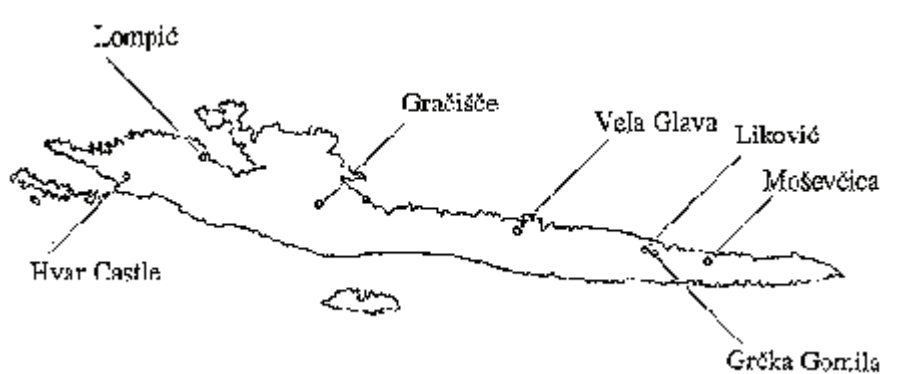

Figure 21. Distribution of hillfort sites with boundaries defined through GIS modules

The seven principal hillfort sites under consideration are those at Moševčica, Liković, Grčka Gomila, Vela Glava, Gračišće, Lompic, and Hvar Castle. The site on Hvar Castle has been

extensively damaged by medieval and modern development but the quantity of prehistoric pottery on the slopes leaves little doubt that a very large site existed here. Presumably any ramparts that did exist here were destroyed long ago. The distribution of these sites on the island is shown in figure 21.

We can construct traditional catchments around these seven sites by simply imposing a series of circles with 1, 2 and 5 km. radius centred on each hillfort. The result of this simple operation can be seen in figure 22. This illustration clearly shows a considerable degree of overlapping of catchments especially between the Likovic and Grcka Gomila sites which are on adjoining spurs. This overlap is largely the result of the naive application of simple catchments without reference to the energy cost of moving across the notoriously difficult karst surface. However in the case of Likovic and Grcka Gomila other archaeological considerations led us to decide to exclude the latter site from the analysis. The proximity of two such hillforts is rather curious. Given the need for the defensive ramparts on these sites it is unlikely that two aggressive communities could have existed at such a close proximity. It is possible that the two sites are not contemporary and that only one was in use at any one time. An alternative possibility is that Grcka Gomila is not a settlement site. Survey of the site indicated that despite the massive nature of the ramparts (they are at one point more than 6 metres in height) they did not appear to be fulfilling an efficient defensive role. The largest rampart is facing at a very short distance a small hill of the same height. Similar situations have been recorded for hillforts in Britain where it has been suggested that such sites may have had a ritual rather than defensive role (Bowden and McOmish 1987, 1989). We therefore decided to exclude Grcka Gomila from the analysis.

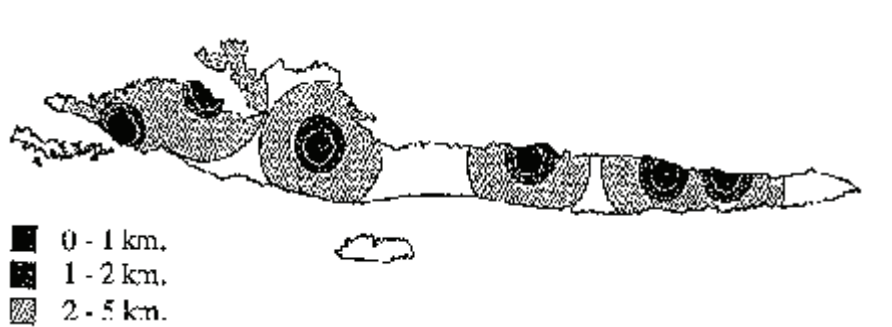

Figure 22. Traditional and GIS derived catchments for the Gracisce hillfort

Despite removing this site from the sample some degree of territorial overlap still remains. We can overcome this problem by using GIS to replace the simple catchments with ones derived from a cost-surface analysis. As explained earlier in the text, the GRASS system includes a module to calculate a relative cost surface across a landscape using the Digital Elevation Model. The cost surface shows the relative energy consumption expended when an individual crosses from one point to another. We can refine this further through our knowledge of the island and by using a measured time for walking across the 5 km. of the Stari Grad plain as the basis for the construction of the hillfort catchments. The same energy requirement for walking 5km. on the plain will produce a different catchment for each site depending on the surrounding topography. If the land crossed is steep in one direction the energy use will be greater and the distance to the edge of the catchment shorter. If the land in another direction is relatively flatter this will be reflected by a longer distance to the edge of the catchment. In considering these results we should note some problems that may arise from the decision to use the distance covered by the energy cost of a walk of 5 km. as the basis for analysis. A walk of this distance amounts to a projected time of c. 90 minutes. This time falls in between the estimated boundary for sedentary agricultural communities at 1 hour and that of herding/hunting communities at 2 hours (Bintliff 1977, 112). Consequently, there is a possibility that we might be over-estimating the size of the catchments.



Figure 23. Traditional and GIS derived catchments for the Gracisce hillfort

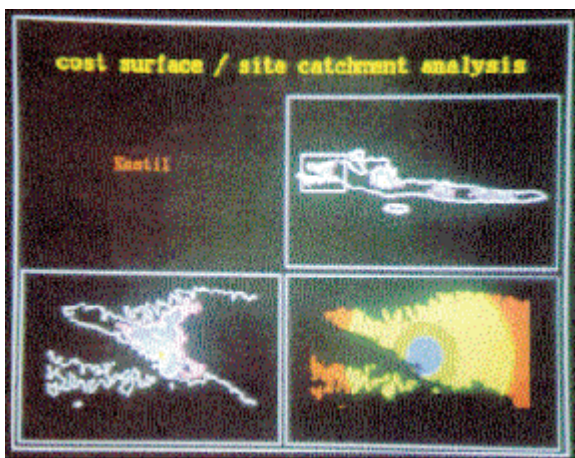

Figure 24. Traditional and GIS derived catchments for the Hvar Castle hillfort

Despite these possible problems we can demonstrate the process of constructing a catchment using the Gracisce and Hvar Castle sites as examples. In figure 23 we can see the difference between a simple catchment for the Gracisce site and one produced using a cost surface analysis. As one might expect the area to the north which includes the flat Stari Grad plain produces a greater distance to the edge of the catchment. In this direction the cost surface almost reaches the boundary of the traditional catchment. The area to the south which is in the direction of the mountainous spine of the island produces a far shorter distance to the catchment boundary.

The Gracisce catchment contrasts very strongly with that produced for the Hvar Castle site (figure 24). Here the catchment is quite severely curtailed both by the coastline and the difficult countryside to the West and East. Significantly longer distances to the edge of the catchment can be seen to the South East where an area of flysch outcrops and provides a smoother landscape with relatively easier access and the area to the North where the route of the modern road leads to an upland plain around the village of Brusje.

The boundaries for all the six sites now being used in the analysis are easily calculated and superimposed on the outline of the map of Hvar (figure 25). It is satisfying to note that the catchments shown in this figure are almost completely mutually exclusive. The catchment at Lompic is suspiciously small - a point which will be returned to later in the chapter.



Figure 25. GIS catchments for major hillfort sites on the island of Hvar

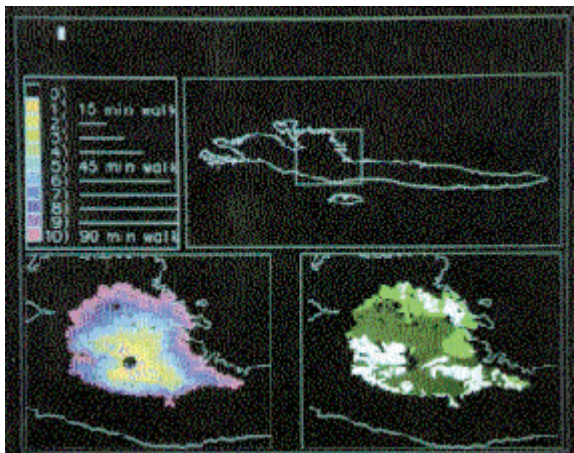

Figure 26. Gracisce catchment and soil types

Having constructed these catchments the GIS software can then be used interactively to examine the environment within the catchment boundaries. Figure 26 shows how we can impose the information we have on soils within the Gracisce catchment. The same exercise can be repeated for all the sites and the results of this exercise can be seen in figure 27. The same routine can be repeated for all the environmental variables we have available in this case study.

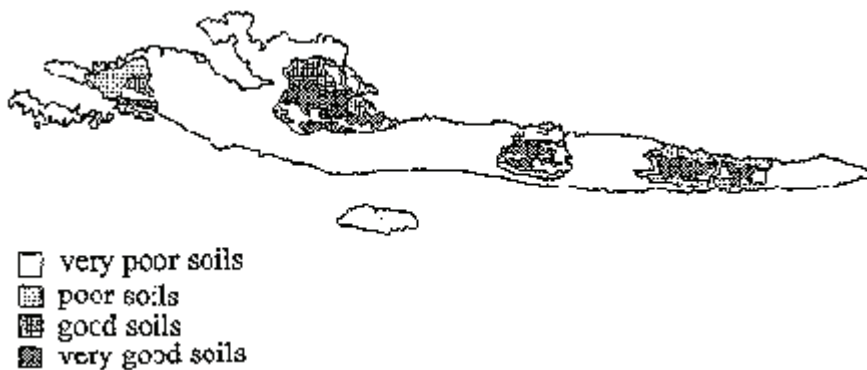

Figure 27. Hillfort catchments and soil types on the island of Hvar

The statistical modules built into most forms of GIS can be used to analyse the varying proportions of environmental variables held within these catchments. At the simplest level we can calculate the area of the catchments, this information is shown in histogram form in figure 28. We can also confirm the presumed association between hillfort sites and control of good arable land simply by quantifying the percentages of different land classes within a catchment and

comparing the results with proportions available for the whole island (figure 29). If the sites are situated to control the best land we would expect that there would be proportionately more of the best land within the catchment.

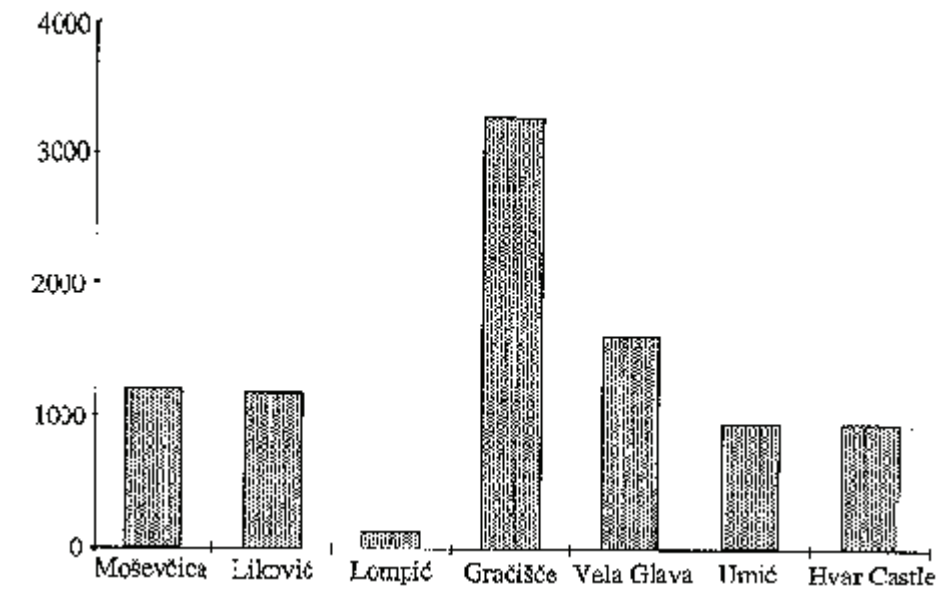

Figure 28. Relative size of hillfort catchments in hectares



Figure 29. Hillfort sites and pie charts illustrating the proportion of soil types within individual catchments (Click for larger image!)

In figure 12 we can see that the two best classes of land cover about 40% of the surface area of the island with the top class covering c. 21%. The sites at Liković (64.5%), Vela Glava (51.2%) and Gračišće (72.5%) show a distinctly larger proportion of better and good land within their catchment than we would expect on comparison with the island as a whole. Mosevcica (38.3%) has slightly less than we might expect. However, the quantity of very good land (34.7%) is rather more than we might have expected, and this might explain the siting of the hillfort. The site of Hvar Castle would also appear to be an anomaly. It contains only 26.5% of good and very good soil classes within its catchment. The area of the catchment is also comparatively small (figure 28). However, the site catchment includes some of the most fertile soils on the island, specifically those light soils developing on the flysch. The flysch is also an aquifer and the provision of water is less of a problem here than elsewhere on the island. Consequently, the hillfort at Hvar Castle is sited in one of the best positions on the island with respect to the critical environmental variables of soil quality and water.

Lompić, however, is an anomaly. We have already noted above that the site's catchment was curiously small. The data on soils clearly indicates that the reasons for the positioning of this site were not agricultural. Even though a visit to the site indicates that a few of the nearby bays could have maintained some fields they are negligible in comparison with the catchments of the other hillforts. Given our knowledge of the archaeology of the island and the position of the site we can suggest with some confidence that Lompić was located to observe activity in the Stari Grad bay, and was perhaps an outpost of the settlement in Hvar Castle.

The strong association of these sites, with the exception of Lompić, with good soils demonstrated above is clearly shown by inspection of the illustration comparing sites and their catchments with

soil types in figure 27. However although all major hillfort sites are associated with large blocks of good land there still remain several areas of good land which do not have an associated site. These include the area to the North -East of Hvar, that between Vela Glava and Likovic and the area around Sucuraj on the extreme Eastern tip of the island.

These gaps in the pattern may indicate that some sites remain to be discovered in these areas. Recent work by a local archaeologist in the area around Sucuraj suggests that one of the missing settlements may have existed at a site called Umic. Here the construction of a water reservoir unearthed considerable quantities of prehistoric pottery. On the assumption that this represents one of the missing settlements we have redrawn the catchment/environmental variable maps to include Umic in figure 30. There is also further compelling evidence in the distribution of cairns that suggests the area between Likovic and Vela Glava must contain another site and we will return to this problem in the next chapter. Unfortunately we can offer no suggestion as to where such a site might lie.



Figure 30. Soils and hillfort catchments including the Umic site

The area to the North East of Hvar Castle is more problematic. There is no other archaeological evidence to suggest the presence of another site here. The anomalous hillfort at Lompic may indicate that the political authority of the site at Hvar Castle may have stretched farther than its predicted catchment and that this area may have prevented the growth of a separate site within the area in between the two sites. However, we should not discount the possibility that the difficulties of obtaining adequate water supplies on the upland plain may well have discouraged settlement.

One final point can be made using this particular data set. We have noted that the hillfort sites appear to be situated to control large amounts of good land. However, these sites also have a defensive function which is not best fulfilled by placing sites on the best land. They need hilltops or ridges that can also be defended, and these topographical situations on the karst do not normally provide the best soil. We can demonstrate this by using GIS to analyse the point that represents the site - a theoretical 20 x 20m. square. This analysis indicates that despite the preponderance of good soils within the catchments of the hillforts all the sites are on poor or very poor soils except for Hvar Castle and Gracisce. These exceptions partly reflect errors resulting from the inadequacies of available maps. These errors and the position of the Hvar Castle site on a defensive point on the limestone at the very edge of the flysch has resulted in the site being placed incorrectly within the flysch zone. Gracisce on the other hand is the most accessible of the sites considered in this analysis. Here the need to provide access to large amounts of good land in the surrounding area appears to have compromised the defensive position of the site.

The analysis carried out above has demonstrated the simplicity of applying GIS to one established archaeological technique - SCA. We can suggest on the basis of this analysis that seven, and possibly eight major centres existed on the island at Hvar Castle, Gracisce, Vela Glava, Mosevcica, Likovic, Umic and the hypothetical site in between Vela Glava and Likovic. We might add the less likely possibility that there is another site to the North East of Hvar to this list. The analysis has also demonstrated the relationship of this category of site to large blocks of good

soils and suggests that such sites were placed with reference to the need to control the best soils. In the case of Lompic the analysis has indicated that the size of such sites is not enough to justify their placement within this group and that this particular site must have had a specialist function, possibly as an outpost monitoring ship movements in the Stari Grad bay.

Doubtless a critic might suggest that SCA could have done this without the need to recourse to expensive computer equipment and undoubtedly such a statement would be true. Whether such an exercise could have been carried out as efficiently may be open to question. The automation of this work also allows the archaeologist to look around the site and to place it rapidly within its wider context. This is surely a useful development. The difficulty of manipulating large amounts of environmental data restricts archaeologists to site analysis and they can lose a wider perspective as a result. One other interesting point should be emphasised here. In some ways GIS' use of the DEM to calculate the catchment is more practical than direct work in the field. The karst landscape has developed considerably since prehistoric times. The modern countryside is a testament to millenia of construction. Walls, terraces, roads and tracks now cover the surface of the land, often possibly in opposition to the access routes used by past peoples. Any attempt to traverse such areas would now probably take an inordinately long time, whilst to try and walk in a straight line to the edge of the hypothetical catchments in the 90 minutes proposed would probably result in the breaking of legs. Perhaps GIS also has a role in making field archaeology that little bit safer!

6. CAIRNS AND TUMULI: AGRICULTURAL CLEARANCE OR RITUAL ACTIVITY

6.1. Problems in the definition of stone cairns and tumuli

Stone cairns are by far the most numerous archaeological monument type on the karstland of Dalmatia. Despite this, the study of these mounds is a problematic issue in Yugoslav archaeology. In the past these large prominent piles of stone have almost universally been classified by archaeologists as funerary monuments, despite the fact that upon excavation only 50% may actually contain any form of burial (Chapman et al. 1987, 126). When these mounds are found to be empty we can suggest that, given the nature of karst agriculture, many of these mounds are the product of the clearance of stone from fields for agricultural purposes. The dating of these mounds is also problematic. When excavated and found to contain burials the use of mounds as burial monuments can be shown to date throughout the last two millennia B.C. and in parts of Dalmatia they were also used during the Roman period.

The work carried out by the Neothermal Dalmatia Project on the cairn field at Pridraga is important within this discussion (Chapman et al. 1987). Here, a very large cairnfield containing some 245 cairns has been demonstrated to represent agricultural clearance from the later Bronze Age. The implications of these results for archaeological field survey on the karst are very important. The Pridraga cairnfield suggests a far more extensive agricultural use of the karst in prehistory than was previously believed. The distribution of these mounds may, therefore, be an indirect indicant of early settlement and the intensity of land use in prehistory.

A further complicating factor in the analysis of these monuments is the observation that when cairns do prove to have a funerary purpose they may also have functioned as agricultural clearance features as well. We should not assume that this dual use was simply pragmatic or unconscious, such actions may have been deliberate and may have held considerable significance to early farmers. This apparent confusion between the arcane and the familiar is not uncommon in many societies.

6.2. The analysis of stone cairns on the Island of Hvar

With these particular problems in mind, we decided to use GIS to investigate whether there was a direct relationship between cairns and agriculture. It was also hoped that such work would also isolate those cairns or groups of cairns which did not have an overt agricultural rationale.

There are nearly two hundred mounds of presumed ancient date scattered around the Island of Hvar. The actual number is probably many times greater than this. Unfortunately, later land use, especially the dramatic intensification of viticulture during the late nineteenth to early twentieth centuries, resulted in the creation of hundreds of thousands of clearance cairns over the whole island. Consequently, identification of earlier mounds within this landscape is very difficult and is generally confined to the larger examples. Many smaller mounds probably exist submerged within later clearance.

Of the several hundred mounds that are recorded in the island Sites and Monuments Register only 18% have provided evidence of internal burial through excavation or chance discovery. Where information is available, all of these burials are prehistoric in date and range from the earlier Bronze Age through to the first century B.C. These mounds vary in size from ten to more than thirty metres in diameter and they occur singly and in groups, the largest of which contains twenty two mounds. Whilst almost invariably constructed of stone one example of a mound constructed of scooped up earth was recently discovered at Zemunjeva Gomila. Later research revealed a reference to a similar mound in a fourteenth century statute from the island and this suggests that other examples of soil mounds may have existed elsewhere on Hvar (Kovacic 1987). Figures 31 and 32 show the distribution of known cairns and tumuli across the island.



Figure 31. The distribution of stone cairns

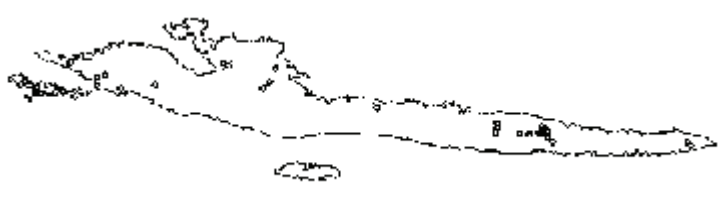

Figure 32. The distribution of tumuli

The first analysis carried out on these monuments was to test their assumed role as agricultural clearance features. If this was the case we would expect some direct relationship with good agricultural land. In such a short publication we could not attempt to analyse all these monuments individually so we chose to look at cairns and tumuli as one class. The most direct method to illustrate association between these monuments and agriculture is through the GRASS statistical module, the output of which is illustrated below in table 2 provides a chi square analysis of the relationship between the numbers of sites and their occurrence on good soils. The relationship between expected number of sites and actual numbers of sites is demonstrated in histogram form in figure 33.

Soil type	Percentage Cover	Expected Number	Actual Number	Chi Square	Degrees of Freedom
Very Good	21.0	39.40	73	28.603	1
Good	18.9	35.60	11	16.96	1
Poor	30.8	57.90	62	20.283	1
Very Poor	29.3	55.10	42	23.103	1
Total	100.00	188.00	188		3

Table 2: Statistical association between cairns and tumuli against soil types (Please note that cairns and tumuli occurring on areas without soil classification data are excluded from this table.)

number of sites

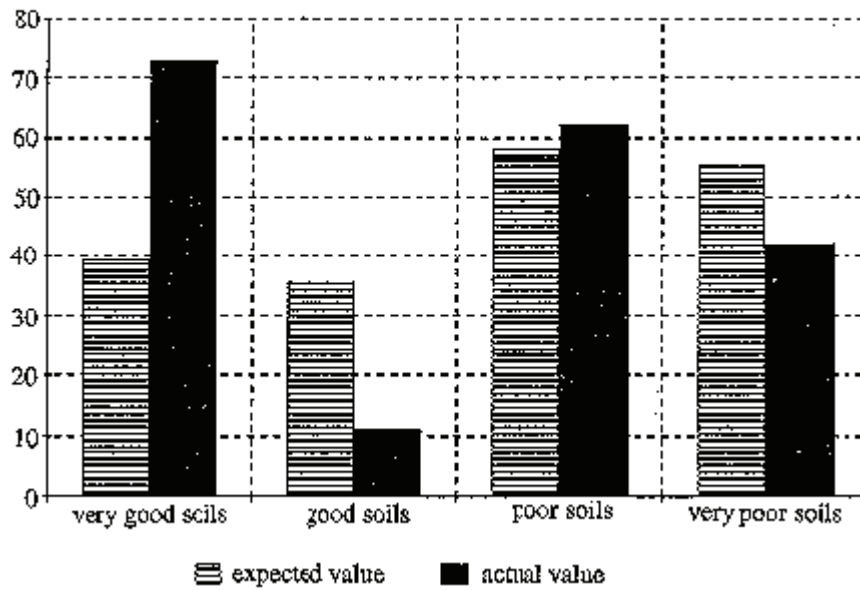

Figure 33. Cairns and tumuli: expected and actual occurrences against soil type

There is a clear statistical association between cairns and the very best agricultural soils. Cairns occurring on poor and very poor soils show a strong negative association. Given that the cairns are composed of collected stones we might consider that the lithology may be reflected in the distribution of cairns. Again we can investigate this relationship using GRASS' statistical module displayed in the same way in table 3 and figure 34.

Lithology class	Percentage Cover	Expected Number	Actual Number	Chi Square	Degrees of Freedom
Limestone and Dolomite	4	7.7	8	0.0009	1
Dolomite	6.8	13.1	0	13.14	1
Dolomite with interlayered Limestone	30.4	58.7	64	0.47	1
Limestone	56.2	108.4	97	1.20	1
Flysch	0.8	1.5	9	38.95	1
Alluvium	1.8	3.4	15	39.84	1
Total	100	193	193		6

Table 3: Statistical association between cairns and tumuli against lithology (* Please note that cairns and tumuli occurring on areas without geological classification data are excluded from this table.)

number of sites

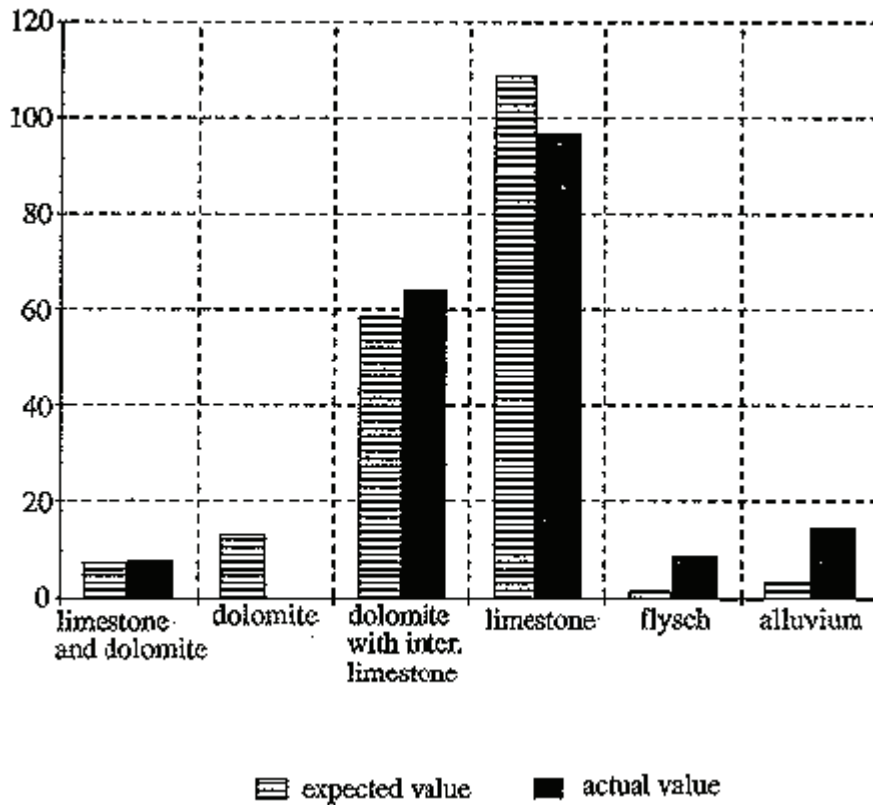

Figure 34. Cairns and tumuli: expected and actual occurrences against lithology

The data indicates that pure dolomite has a negative association with the distribution of cairns. This is not surprising as this area forms the most mountainous, least accessible part of the island and has some of the worst possible soils. The only lithologies that illustrate clear positive associations are the alluvium and flysch, both of which would also be expected to provide excellent agricultural soils. However some caution must be advised when considering these figures. The association of the cairns and flysch is actually the result of the poor resolution of the environmental data. Most of the barrows associated with the flysch are actually on limestone cliffs at the interface of the limestone/flysch zone. In reality only the alluvium has any strong statistical association with cairn distribution.

This data suggests that geology does not appear to display any strong influence over the distribution of cairns as a group and that agricultural potential is a more significant variable. This is clearly demonstrated when we overlay the distribution of cairns on soils within the catchment of the Gracisce hillfort (figure 35). With the exception of one site all the cairns cluster on the best soils.

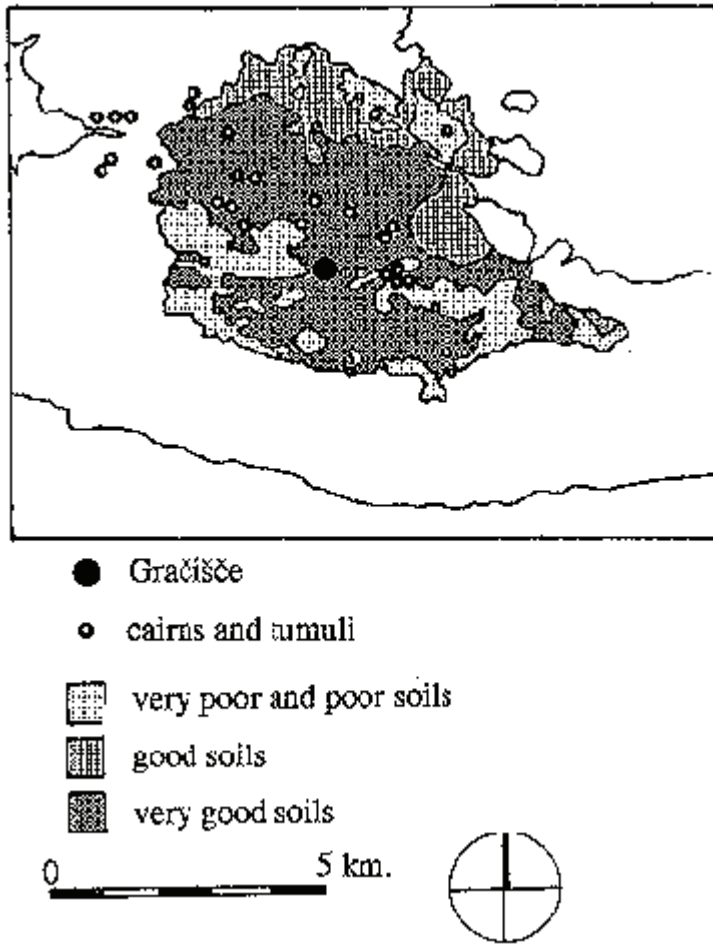

Figure 35. Cairns, tumuli and the Gracisce catchment

The role of these mounds as ritual and funerary monuments was pointed out at the beginning of this analysis and some hint of this can be seen when the distribution of cairns within the catchment of the site at Hvar Castle is considered (figure 36). Within this catchment good soils are generally restricted to the flysch zone which lies to the east of Hvar. Although there is a concentration of barrows around this zone the flysch itself is soft and there is less need for the massive clearance seen on other geologies of the island.

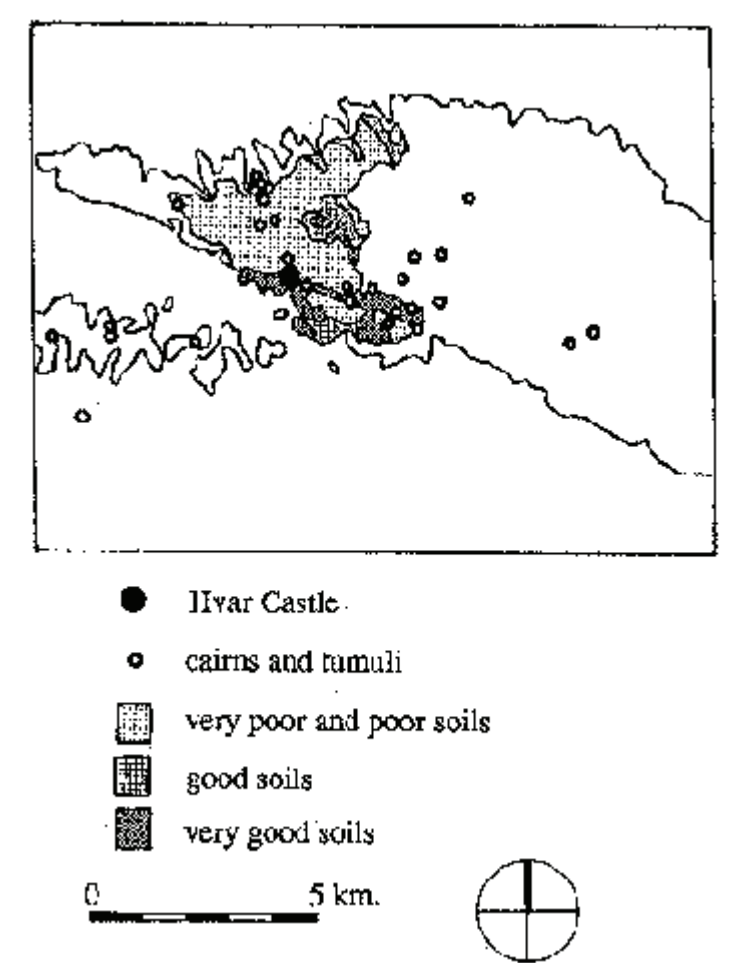

Figure 36. Cairns, tumuli and the Hvar Castle catchment

In contrast to the distribution of cairns within the Gracisce catchment the most spectacular concentration of mounds around Hvar Castle is to the North West of the town and concentrated around the bay at Vira (figure 37). In fact this area contains the largest group of cairns on the island. Some of the mounds in this group are very large and include one double mound and another which might originally have contained an inner chamber. The large size of the group and the position it occupies just beyond the edge of the Hvar Castle catchment sets it apart. It does not have an obvious agricultural rationale. It lies within an area of poor soil forming part of the Pelegrin peninsular which in the past was largely used for communal grazing. Although it should be argued that such areas may have had a more substantial soil cover in the past and that there is a limited area of useful soil in the adjacent valleys of Mala and Vela Vira, past agriculture could probably not explain the massive amount of clearance associated with these mounds.

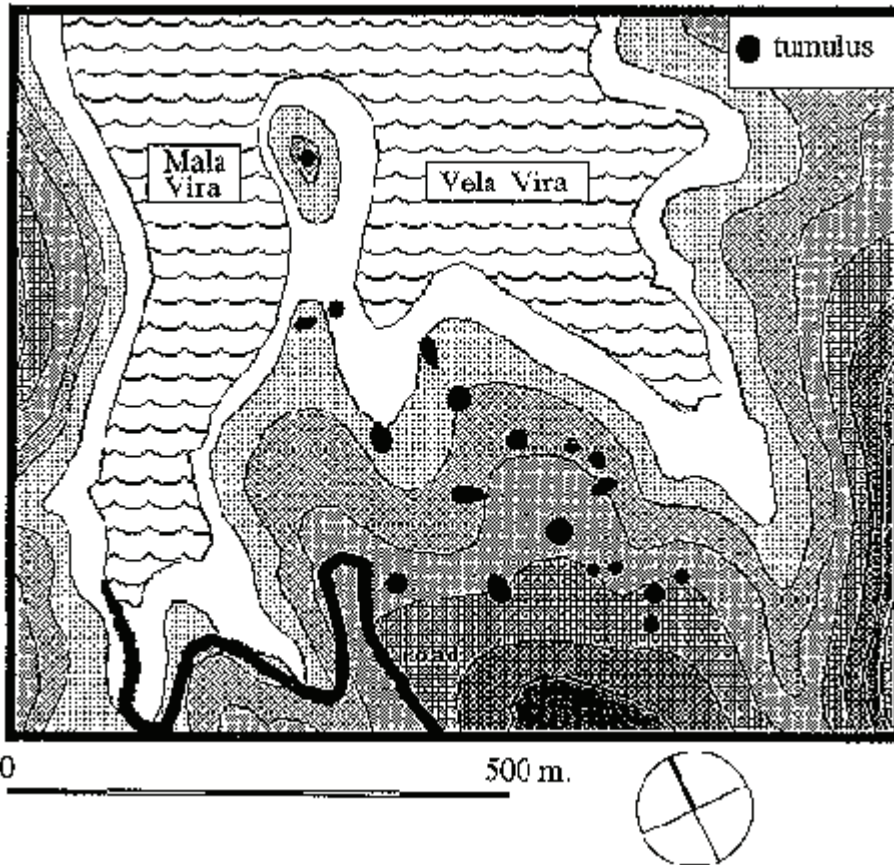

Figure 37. Tumuli within the bay at Vira (after Zaninovic 1978b)

The layout of the barrows also hints at a non-agricultural purpose. All the barrows are situated so that they have visual contact with one small mound situated on the very centre of the peninsular of Vira. The deliberate use of this mound (sadly destroyed in 1989 during the construction of a firebreak for an autocamp) as the focus of the group suggests that complex had a ritual function and its proximity to the Hvar Castle site associates the burials with the inhabitants of that site. The differences between the distribution of cairns at Gracisce and Hvar Castle illustrate how similar monuments may be sited for different reasons and suggests that further work on this problem would provide interesting results.

Work at the Pridraga cairnfield carried out by the Neothermal Dalamatia Project suggested that the distribution of cairns might provide further insight into prehistoric settlement patterns (Chapman et al. 1987). This interesting proposal is particularly significant given the suggestion in an earlier chapter that gaps in the distribution of hillfort sites on the island indicate that several sites may remain to be discovered. If major hillforts are placed to dominate good agricultural land and cairns in part reflect the intensity of prehistoric agriculture there should be a coincidence between the distributions of both sites. In order to investigate this we have overlaid the distribution of cairn sites over agricultural land in the eastern part of the island in figure 38. This clearly shows the strong positive relationship between good soils and cairns and tumuli. However it is significant that whilst there is a coincidence between the distribution of cairns and good soils within the catchments of Vela Glava ad Likovic, there is also a significant concentration of stone mounds in the area of good agricultural soils in between these sites - in the area where we had predicted that another major prehistoric settlement site remains to be found.

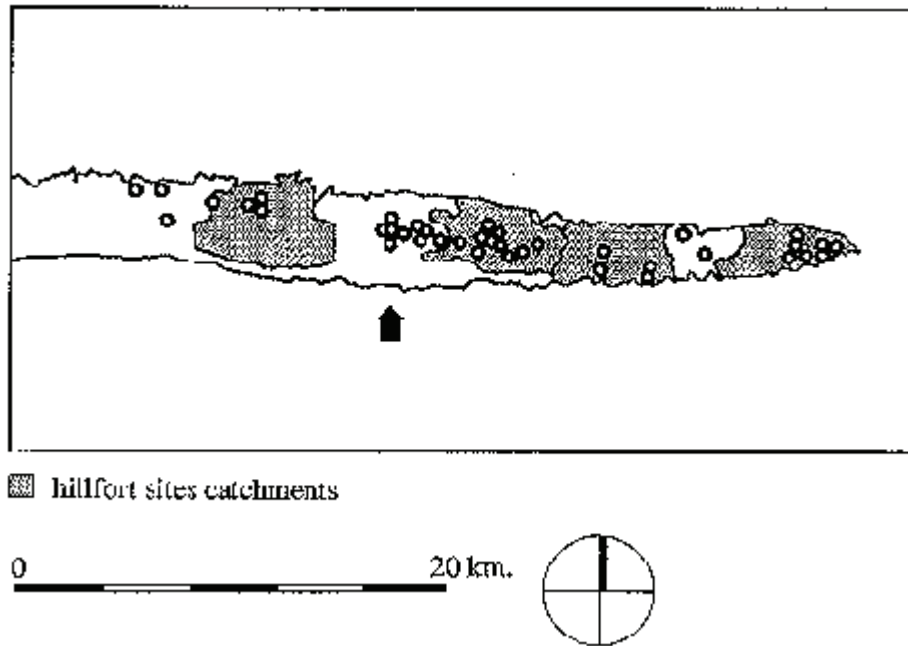

Figure 38. The distribution of cairns and tumuli within hillfort catchments on the eastern part of the island of Hvar

The significance of these cairns to land use and settlement becomes clearer when we consider the remaining block of good soil without a hillfort identified in the previous chapter and which lies to the North East of Hvar Castle. Figure 36 shows the distribution of cairns on the Western part of the island and includes this area between the hillforts at Lompic and Hvar Castle. Despite the availability of good soil there are very few recorded cairns in the area. Although this may reflect the lack of survey work within the area the suggestion has already been made that this area may have rested under the control of the site at Hvar Castle and that a separate major hillfort might not have been able to develop here. If this was the case the peripheral nature of the area to the settlement of Hvar Castle site also have prevented intense agricultural clearance from taking place and would explain the apparent lack of cairn construction.

The work presented here goes some way to confirming Chapman et al.'s (1987) suggestions concerning the agricultural nature of cairns and their use in the analysis of past settlement and land use within GIS applications. However, the points where the GIS analysis shows a lack of correlation between agriculture and cairns also emphasises the need to consider non-environmental variables within the overall analysis of archaeological distributions and specifically the role of belief systems. This is the point where GIS stops and the experience and theoretical stance of the archaeologist takes over.

7. ROMAN VILLAS IN THE LANDSCAPE

The Roman period on Hvar provides the greatest number of surviving archaeological settlements on the island. In large part this is due to the methods of construction used for structures of this period. The durability of Roman architecture is well known and the remains on Hvar are no less hardy than those from other parts of the Empire. Standing remains, some up to several metres in height are not uncommon on the island. However, the number and variety of sites on the island whose distribution is shown in figure 20 also indicates that the period was one of prosperity and growth.

Pharos (Stari Grad), the sole town on the island, expanded considerably during this period. The town appears to have been equipped with a bath and buildings with hypocausts as well as, in the later Roman period, churches (Nikolanci 1958). However, the most remarkable change is in the rural areas. Here there is a dramatic expansion of settlement across the whole countryside. Agricultural settlements (villas) of varying sizes are indicated by large scatters of pottery, tile and other building materials. Occasionally extensive stretches of original walling can still be seen. The most frequent surviving remains are water cisterns, some of which are still being used by modern farmers. Architectural fragments, marble sheeting and the remains of tessellated pavements indicate that the larger establishments were quite luxurious and some at least were the centre of large country estates administered by bailiffs.

The agricultural basis of these settlements is indicated by the remains of oil and wine presses which are frequently found on such sites. We have already demonstrated the ease with which it is possible to correlate archaeological sites with soil quality and a similar procedure can be carried out using the Roman data. Again we can use the GRASS statistical module to provide data on site occurrences in order to show correlation. These figures are given in table 4 and displayed in histogram form in figure 39.

Soil type	Percentage Cover	Expected Number	Actual Number	Chi Square	Degrees of Freedom
Very Good	21	30.6	89	111.42	1
Good	18.9	27.7	34	1.45	1
Poor	30.8	45	8	30.46	1
Very Poor	29.3	42.7	15	17.96	1
Totals	100	146	146		3

Table 4: Statistical association between all Roman settlement sites and soils (Table excludes sites with no environmental data.)

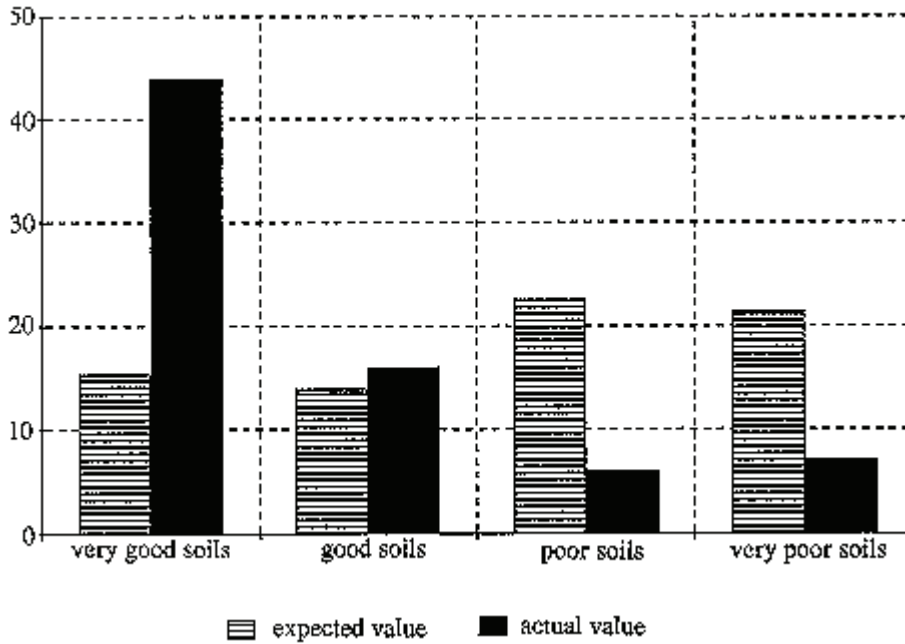

Figure 39. Correlation of Roman settlement sites and soil types

This data shows a very clear preference for the most productive soils on the island. The two poorest classes of soil are clearly avoided. No particular preference is shown for the "good" category of soils, presumably this reflects the lower economic returns from this land or perhaps the need for settlements to farm a larger area in order to provide a significant return.

Given the large data set for the Roman period we can develop this type of analysis further by attempting to consider a second variable in settlement location other than soil quality. In table 5 and the histogram in figure 40 we can see the correlation statistics for Roman settlements and climate. This data also indicates that there is a marked preference for Roman activity in those areas of the island defined as having a "better" climate.

Climate Class	Percentage Cover	Expected Number	Actual Number	Chi Square	Degrees of Freedom
Best Climate	2.3	4.4	26	106.69	1
*****	10.1	19.5	7	8.01	1
*****	17.8	34.4	93	99.66	1
****	25.3	48.9	23	13.72	1
***	40.2	77.6	42	16.33	1
Worst	4.2	8.2	2	4.66	1
Totals	100	193	193		6

Table 5: Statistical association between all Roman settlement sites and climate (Table excludes sites with no environmental data.)

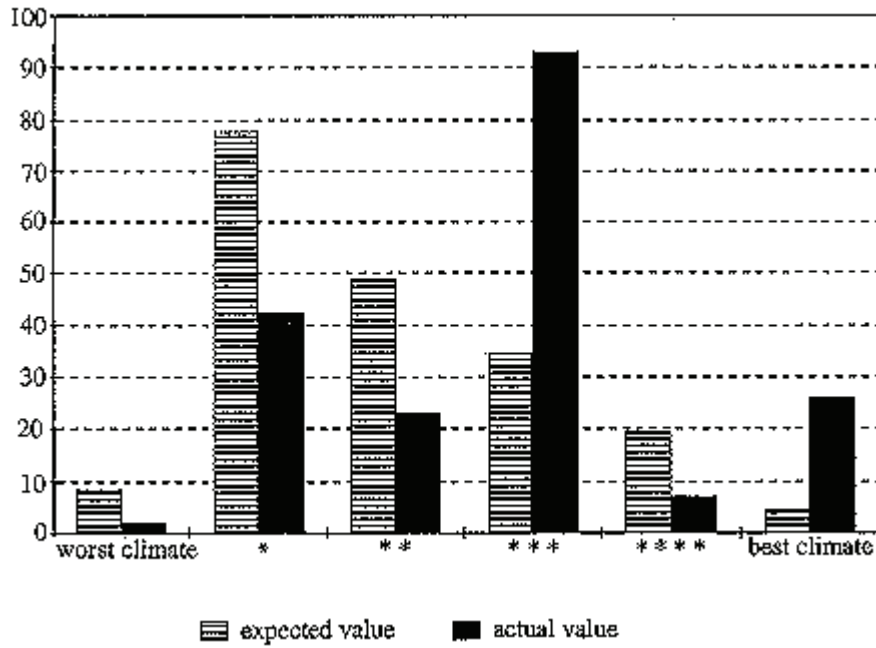

Figure 40. Correlation of Roman settlement sites and climate

Climate and soil type are of course both important variables for agriculture and this data reflects that fact. However we can use GIS to attempt to refine these statements by merging both climate and soil data to produce a map which correlates soil and climate classes automatically and produces a series of new classes defined by the correspondence of varying soil and climate classes within them. The result of this operation can be seen in table 6, ranked by soil type and then by climate type within each class.

A	Site Data		Percentage Cover	Expected Number	Actual Number	Chi Square	Degrees of Freedom
	B	C					
1	1	1	0.0002	0	3	315.49	1
2	2	1	0.1	0.2	1	3.87	1
3	3	1	4	5.9	58	458.92	1
4	4	1	6.1	8.8	10	15	1
5	5	1	14.4	21	19	0.1	1
6	6	1	0.2	0.3	0	0.3	1
7	1	2	0.1	0.1	0	0.14	1
8	2	3	1.9	2.8	2	0.2	1
9	3	2	3.7	5.5	9	2.28	1
10	4	2	6.7	9.9	13	1	1
11	5	2	6.1	8.8	10	0.1	1
12	6	2	0.3	0.4	0	0.43	1
13	1	3	0.4	0.6	0	0.63	1
14	2	3	6.1	8.9	4	2.7	1
15	3	3	7.8	11.4	0	11.43	1
16	4	3	12.5	18.2	2	14.43	1
17	5	3	4	5.8	2	2.51	1
18	6	3	0	0	0	0.02	1
19	1	4	1.4	2	3	0.44	1
20	2	4	2	2.9	0	2.9	1
21	3	4	1.9	2.8	1	1.16	1
22	4	4	4.2	6.1	0	6.08	1
23	5	4	16	23.4	9	8.84	1
24	6	4	3.8	5.5	2	2.2	1
Total			100	146	146		23

Table 6: Statistical association between all Roman settlement sites, soils and climate (A Soil/Climate Class Number; B Climate Class Number. 1 = Best Climate, 6 = Poorest Climate; C Soil Class Number, 1 = Very Good Soil, 2 = Good Soil, 3 = Poor Soil, 4 = Very Poor Soil; table excludes sites with no environmental data)

Classes 1 and 3 stand out as particularly significant within this data set. Both are areas where good and relatively good climate and soils coincide, however, class one which has a very significant chi square result is only represented by six environmental cells of 100 x 100m. Clearly we must show some caution in how we treat this data. In order to allow easy comparison of these results we have also displayed this data in histogram form (figure 41) ranked by chi square. Here we can see that within the top eight ranking classes 1 and 3 are positively associated with the top soil class and the top three climate classes, although the areas covered by classes 1 and 2 are very small and may be ignored. Significant negative associations are indicated in classes 15, 16, 20, 22 and 23. All of these classes are on poor or very poor soil but include climate classes 2, 3, 4 and 5.

chi square value

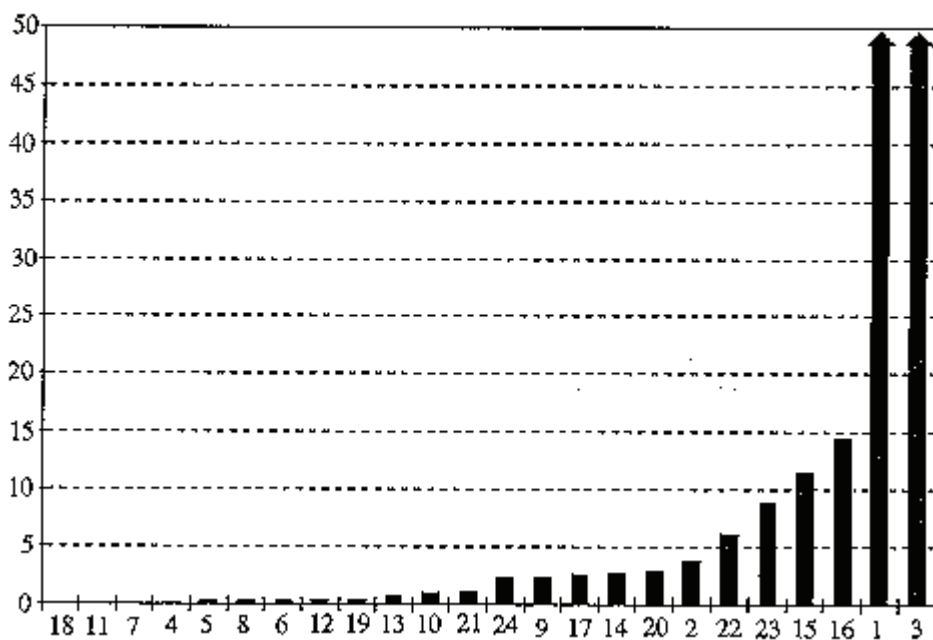

Figure 41. Roman settlement sites, climate and soil ranked by chi square value

The rejection of poor soils without regard for the climate type suggest that where preferences are shown agricultural potential is the most significant factor in choosing or avoiding particular areas. Using this information we have produced a simple model predicting those areas which, during the Roman period, may have been more attractive for settlement as a result of their environmental qualities (figure 42). However, we should emphasise firstly that where expected values in the chi-square test are very low, the results can not be relied upon and that, if we had wished to provide a more useful analysis of this type of data, a sophisticated multivariate analysis would have been necessary (Warren 1990).

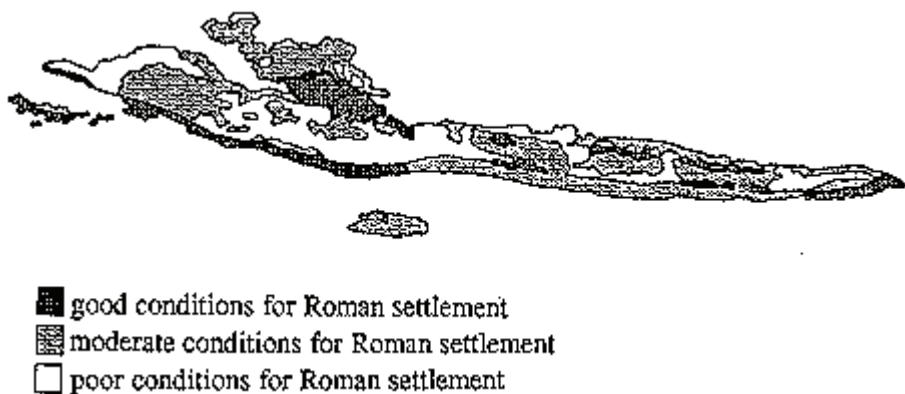

Figure 42. GIS derived model for Roman settlement

We can take a further step in this analysis by considering a homogeneous climate zone and investigating the effect of soils and lithologies within it. The largest and most useful area for such an exercise is the Stari Grad plain in the central section of the island. This area is particularly significant from an archaeological viewpoint because it contains the remains of the Greek and Roman town of Pharos (Stari Grad) and the very large planned Greek field system which runs across the plain from Stari Grad in the West to the village of Vrboska in the east. The plain is the largest fertile area on the island and contains abundant traces of Roman remains (figure 43). Although homogenous in climate the plain contains a variety of soils and lithologies. Known sites

are distributed on these variables in figures 44 and 45, and their correlation statistics given in tables 7 and 8 and in histogram form in figures 46 and 47. It is clear from this data that a strong preference is shown for the very best soils on the plain, the poorer soil classes being generally avoided. Where a preference is demonstrated within the geological data there is a tendency to site villas on the small area of available alluvium and the dolomite with interlayered limestone. The limestone is largely avoided.

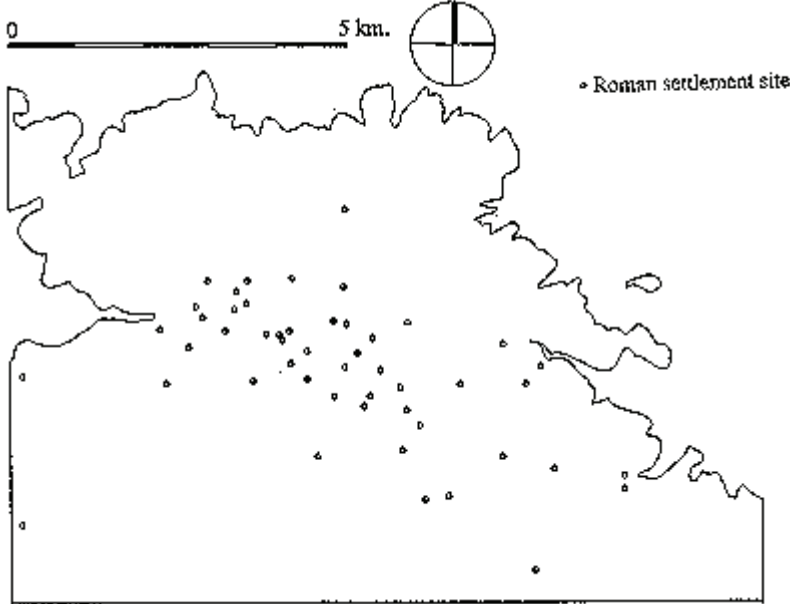

Figure 43. The distribution of Roman settlement sites on the Stari Grad plain

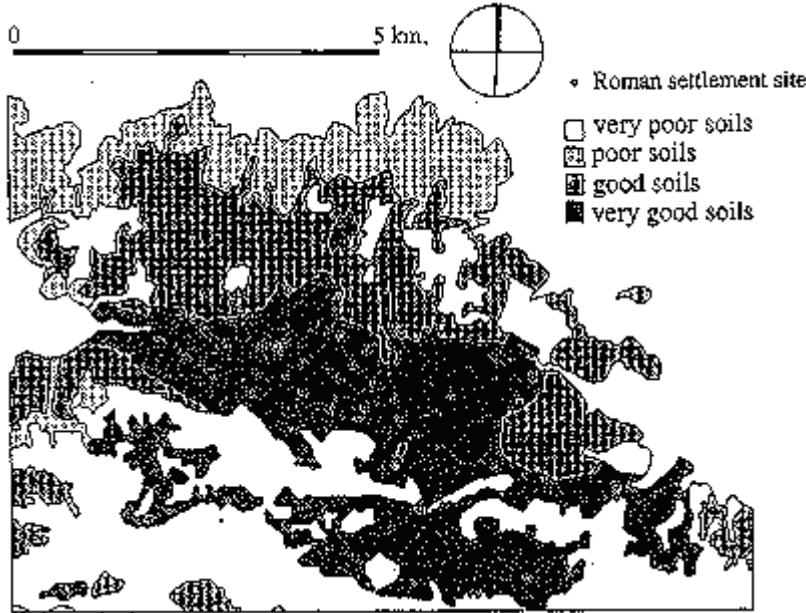

Figure 44. The distribution of Roman settlement sites and soil groups on the Stari Grad plain

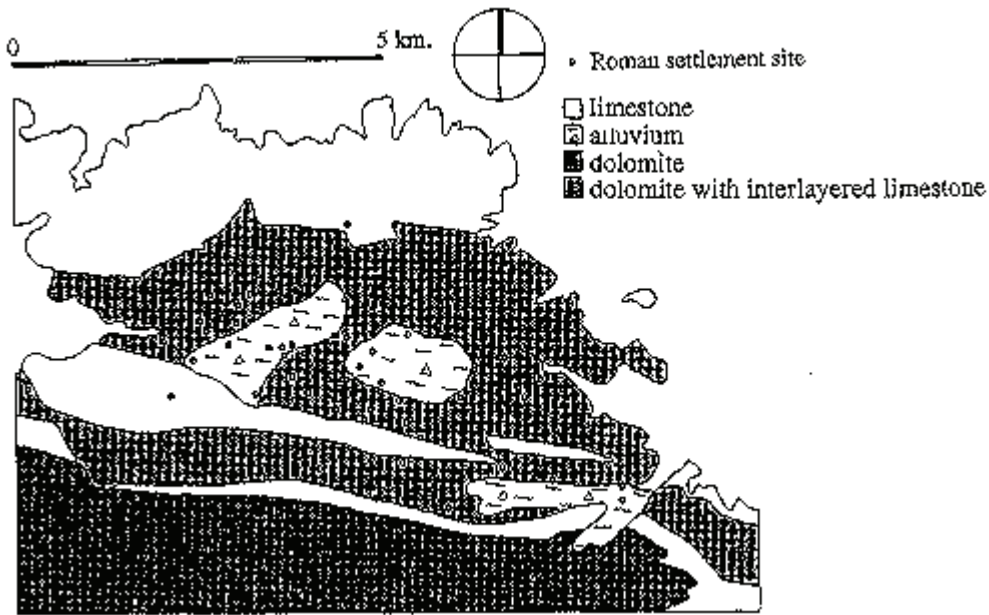

Figure 45. The distribution of Roman settlement sites and lithologies on the Stari Grad plain

Soil type	Percentage Cover	Expected Number	Actual Number	Chi Square	Degrees of Freedom
Very Good	21	15.3	44	53.78	1
Good	18.9	13.8	16	8.34	1
Poor	30.8	22.5	6	12.1	1
Very Poor	29.3	21.4	7	9.67	1
Totals	100	73	73		3

Table 7: Statistical association between Roman settlement sites on Stari Grad plain and soils (Table excludes sites with no environmental data.)

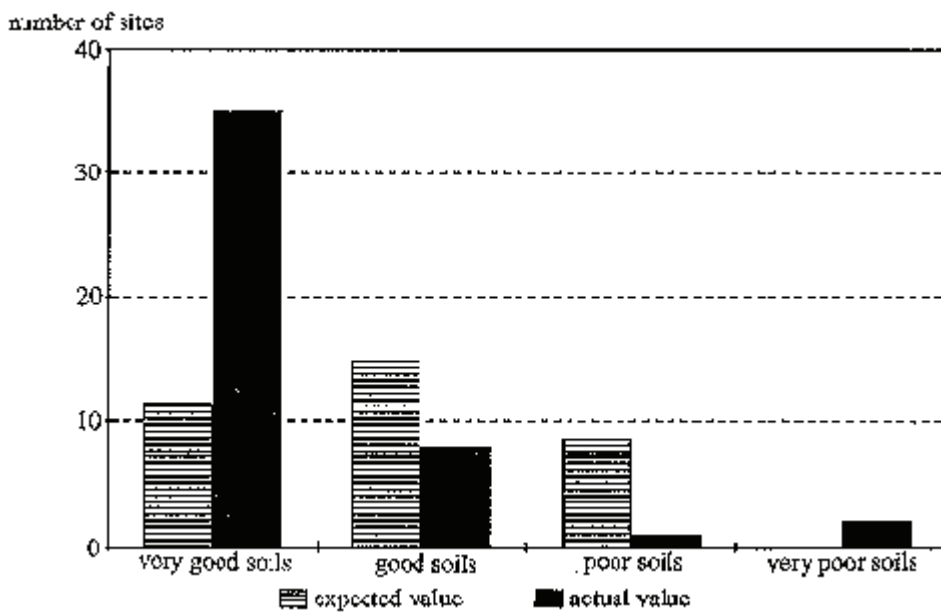

Figure 46. Roman settlement sites and soils on the Stari Grad plain: expected and actual occurrence

Lithology class	Percentage Cover	Expected Number	Actual Number	Chi Square	Degrees of Freedom
Dolomite	7.2	3.5	0	3.5	1
Dolomite and Limestone	43.9	21.5	33	6.1	1
Limestone	40.7	19.9	4	12.7	1
Alluvium	8.2	4	12	15.8	1
Totals	100	49	49		3

Table 8: Statistical association between Roman settlement sites on Stari Grad plain and lithologies (Table excludes sites with no environmental data.)

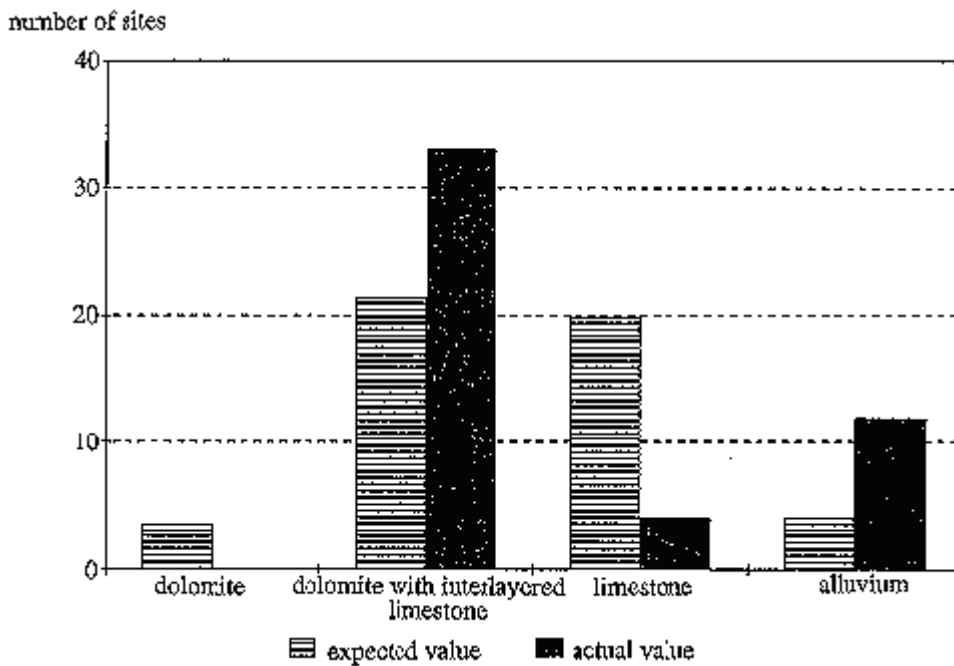

Figure 47. Roman settlement sites and lithology on the Stari Grad plain: expected and actual occurrence

The nature of the relationship between Roman settlement and land is further indicated through analysis of the catchment of a selection of sites from across the island. The position of these sites on the island is shown in figure 48. The catchments used in this analysis are smaller than those of the hillforts because of the underlying assumption that the sites are primarily located for crop production and that land within 2.5km. or c. 40 minutes walking time of the site will contain the majority of efficiently usable land. With the exception of Dolcic, the catchments of these sites show a massive preponderance of good and very good soils with poor quality soils forming a small proportion of the whole (indeed the Sucuraj and U Lazu catchments do not contain any poor or very poor soils). We can underline the importance of soils to these sites by comparing this data with that produced for hillfort catchments shown in figure 29. Although situated to dominate good soils these earlier sites were also placed with an eye to defence, consequently the quantity of good soils never approaches the total representation seen in the Sucuraj and U Lazu Villa catchments.

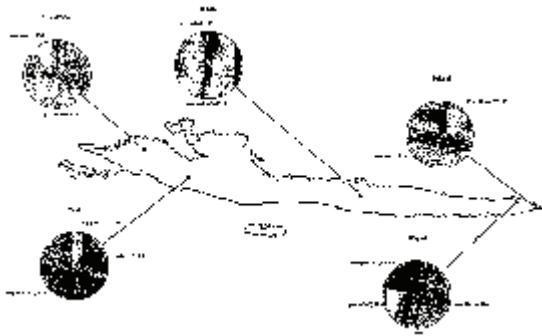

Figure 48. Roman sites with pie charts illustrating the proportions of soil types within GIS derived catchments (Click for larger image!)

Within the Roman data set, Dolčić provides an interesting exception. The site is an isolated and comparatively poor farmstead site on the high plain above Selce. It is an outlier to the majority of Roman settlement sites. The relatively small amount of very good or good land within the catchment (39%) contrasts with the excellent access to quality land demonstrated on other villas. Despite the relative paucity of good land within the Dolčić catchment the distribution of available land which is shown in figure 49 indicates that the site itself has been placed at the centre of the best land in order to make the most efficient use of available resources. It would be interesting to have more information on the date of this site. One suspects that such marginal areas only achieve any degree of intensive usage or success during times of pressure on land production. However, the case of Dolčić clearly illustrates the prime importance of agricultural resources, even to low status settlements, during the Roman period and the deliberate positioning of sites to utilise the best land, most efficiently.

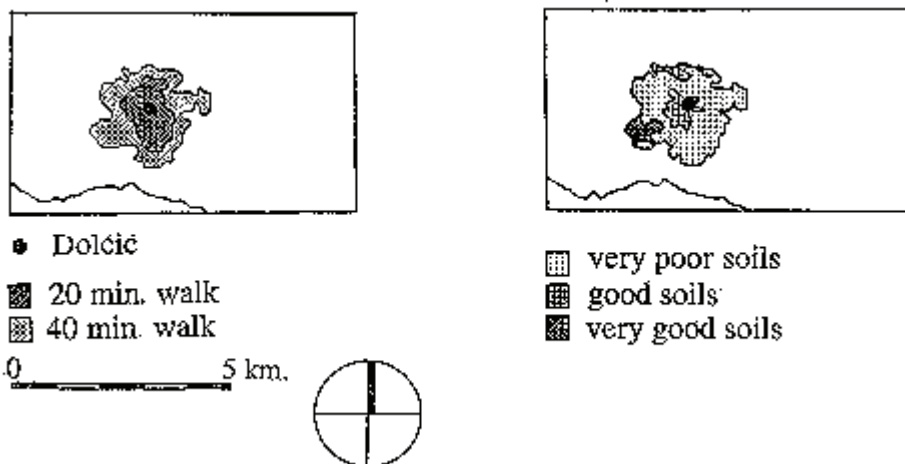
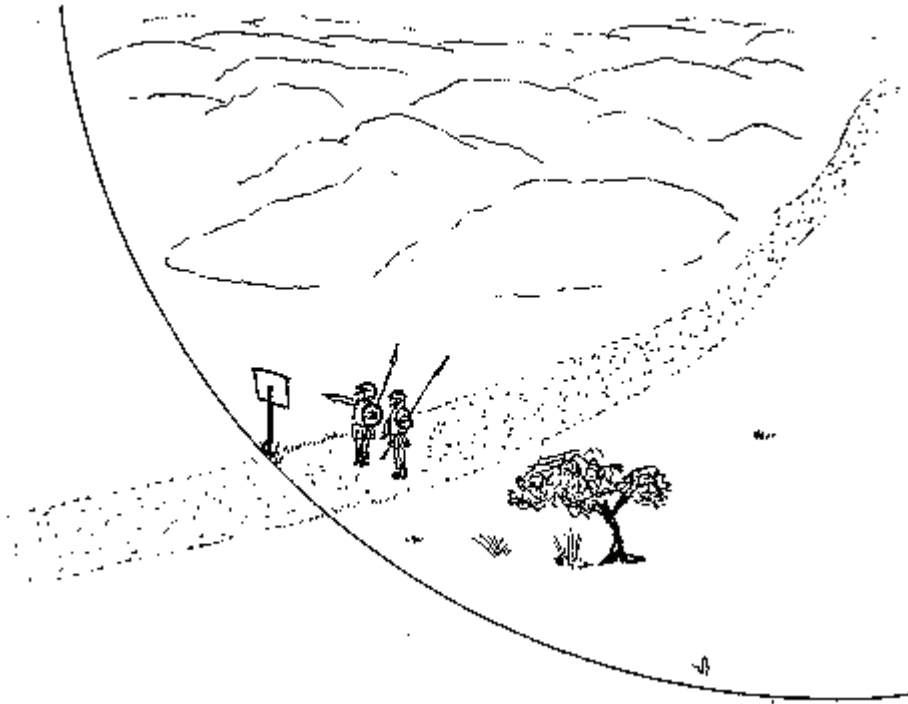

Figure 49. GIS derived territory and soil types for the Roman site at Dolčić

The importance of agriculture in the Roman period should not be compared with that demonstrated for earlier settlement when we have no reason to believe that much beyond basic subsistence agriculture was being practised on the island. In contrast, the majority of the Roman settlements on the island must have been operating within a market economy. The evidence for fine architecture, imported marble, amphorae from many parts of the Mediterranean indicate that considerable quantities of goods were being traded between Hvar and the rest of the Mediterranean world. We can assume that the oil and wine from the presses of Hvar's villas formed the basis of trade to buy luxury items or pay for the construction of the large buildings whose remains can still be seen. The paramount importance of land to this economy is shown in the direct relationship between sites throughout the island and the very best of soils, and the efficient siting of farms to utilise these resources to the full.

The results of the analysis for the Roman period have again demonstrated the use of GIS for correlating archaeological and environmental data with the purpose of indicating the importance of agriculture to the Roman villa system. The attempts at cross-correlating the soil and climate data for the island give a hint at more powerful applications of GIS, unfortunately the data set from Hvar is too limited and the island itself too small to utilise these possibilities to the full. Despite this, the potential of the application in a number of different situations should be clear and the ease with which complicated variables can be reclassified, mapped and analysed will be of great value to any archaeologist.



Cartoon 4. It appears to say "End of 5km catchment. Hunter-gatherers only beyond this point".

8. THE GREEKS ON HVAR: OPTIMAL PATHS AND VISIBILITY ANALYSIS IN ARCHAEOLOGY

The previous case studies have largely involved the definition of the relationship of settlement sites to their agricultural base. This short chapter will look at several very specific questions - the calculation of optimal paths and visibility analysis using data from the Greek period.

The foundation of the Greek colony of Pharos in 385/4 B.C. is an important point in the history of Hvar. The dramatic events associated with the arrival of the Greeks on the island are recorded by the first century B.C. historian Diodorus Siculus in a passage which is worth repeating here;

"This year the Parians, who had settled Pharos, allowed the previous barbarian inhabitants to remain unharmed in an exceedingly well fortified place, while they themselves founded a city by the sea and built a wall around it. Later, however, the old barbarian inhabitants of the island took offence at the presence of the Greeks and called in the Illyrians of the opposite mainland. These to a number of more than ten thousand, crossed over to Pharos in many small boats, wrought havoc, and slew many Greeks. But the Governor of Lissus appointed by Dionysius sailed with a good number of triremes against the light craft of the Illyrians sinking some and capturing others, and slew more than five thousand of the barbarians, while taking some two thousand captive." (Diodorus XV, 14)

Diodorus' account of the founding of the colony on Hvar is a rare insight into the tensions between colonists and natives at the onset of colonisation. Whilst the account given by Diodorus is highly colourful and we may cast some doubt about the numbers of dead and captured, a surviving fourth century inscription (the oldest written record on Yugoslav territory) referring to a victory over the Iadasinoi conveniently confirms the essentials of Diodorus' account (C.I.G. II, 1837). Despite this, the result of the battle between the Greeks and natives on the island was probably not as definitive as Diodorus would like us to believe. The distribution of Greek sites on the island is almost entirely restricted to the Stari Grad plain (figure 19). It is very likely that the Greeks were confined to this area and the rest of the island remained in the hands of the native Illyrian peoples. It is also significant that there is a notable lack of Greek settlement sites within the Greek field system on the plain. This suggests that the majority of colonists remained safe within the town and they rarely felt secure enough to build permanent settlements outside of Pharos.

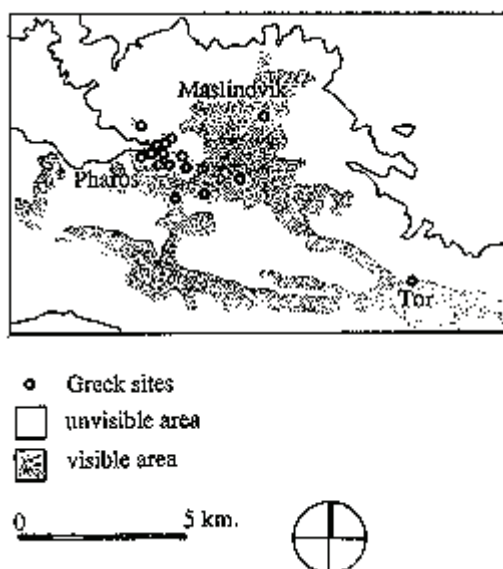

Figure 50. Visibility analysis based on the Greek tower at Maslinovik

The history of the Greeks on the island was probably one of perpetual unease and competition with their Illyrian neighbours. We can explore this to some extent through the use of GIS techniques. At a simple level we can use the hillfort catchments produced in earlier chapters to

suggest that the strongly fortified place in which the "barbarians" were allowed to remain may have been the hillfort at Gracisce whose catchment covers the majority of the Stari Grad plain (figure 23). One suspects that the Greeks were allowed to establish their colony at Stari Grad because it lay just beyond or on the edge of the under-utilised periphery of the hillfort's catchment. Further, we may suspect that relations between the two groups rapidly changed and that an attack was provoked when the activities of the Greeks impinged upon Gracisce's subsistence requirements.

Another sign of the tension on the island is the presence of Greek watchtowers situated at Maslinovik and Tor. The better preserved tower at Tor is a fine example of Hellenistic work. It is constructed from massive blocks of stone with anathyrosis at the corners and stands on a high ridge overlooking the plain of Jelsa. The recently discovered tower at Maslinovik is badly damaged and only survives to slightly above foundation level. There is another defensive site at Purkin Kuk which has been claimed to be part of this system (Zaninovic 1978a, 1981). This is incorrect. The style of construction at this site is very different, amounting to little more than a copy of the towers at Maslinovik and Tor.

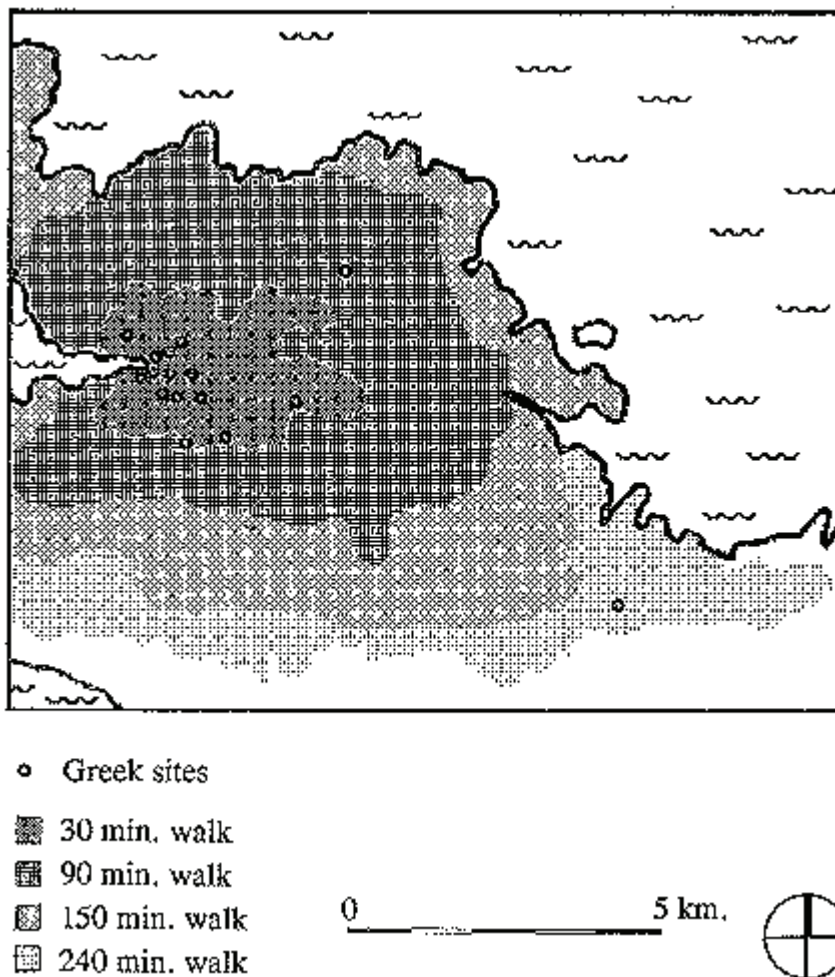

Figure 51. Cost surface analysis between Pharos and the tower at Tor

It is assumed that these towers form an integral system connected to the town at Pharos whereby watch was kept for any approaching danger. Whenever some enemy approached, the townsfolk would have alerted to their peril by signals from the towers probably in the form of fire or smoke (Kirigin and Popovic 1988). This assumption involves the existence of clear lines of sight between the sites or at least from the middle point at Maslinovik. We can use GIS to test this belief. Intervisibility between points can be demonstrated by interrogating the Hvar DEM to allow us to plot the areas which are in direct visual contact with a specified point. The results

using the tower at Maslinovik as the starting point are shown in figure 50. We can see from this illustration that Maslinovik would have been able to see the tower situated to the South East at Tor and be in a position to pass any warning to the inhabitants of Pharos to the west.

Following from this result it is interesting to look at the position of the further tower at Tor and its distance from Pharos. In figure 51 we have run a cost surface analysis from the colony to the tower in order to find out how long it would take to walk between the sites. These results show that, at the very least, it would take about 4 hours to walk to Tor. This implies that the tower was sited at a point to which it was possible to walk to, and return, within one day. This also implies that the Greeks felt the need to be somewhere safe at night and we can interpret this data as further evidence for the level of insecurity felt by the Greek colonists.

The last GIS application carried out using Greek data was to work out the optimal path between the tower at Maslinovik and the town of Pharos. In order to do this the DEM was used to produce a cost surface on the area around the tower at Maslinovik and then re-analysed to produce a least cost path across the cumulative cost surface between Maslinovik and the lower site at Pharos. The results of this operation are shown in figure 52.

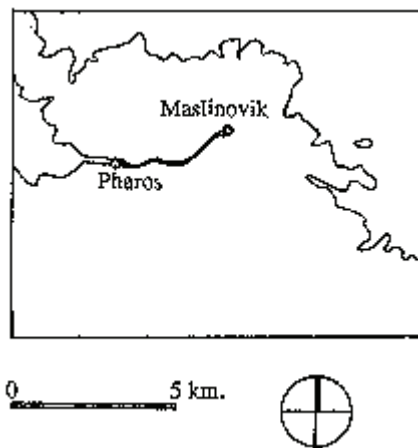

Figure 52. Optimal path between Pharos and the tower at Maslinovik

The potential of optimal path analysis to provide information for archaeologists is great. Such analysis could be related to trade routes or paths relating to specific historic journeys, perhaps with the aim of using the information as the base for predictive survey or the analysis of related data. The calculation of optimal paths is relatively easy but demands a high quality DEM, if this is not available the results can be very strange. Several areas of Hvar were analysed using this GRASS module and in those areas where the DEM was not so good least cost paths were traced running directly up cliff faces. The natives of ancient Pharos were undoubtedly hardy folk, but they weren't that tough!

9. NEOLITHIC SETTLEMENT ON HVAR: ARCHAEOLOGICAL LIMITATIONS AND GIS APPLICATIONS

In the previous chapters, the various analyses have been carried out using environmental or archaeological data in which we can have some confidence. Although there has been a certain amount of change over time we can be fairly confident from our knowledge of Roman agriculture and archaeology that when we show the relationship between villas and soils defined as "good" by modern agriculture the link is a useful one. Even when we consider sites from the Iron Age and Bronze Age and we know that considerable soil changes must have taken place over time, we can still be reasonably confident that the agricultural basis of these societies will allow us to use the data we have on modern soils within prescribed limits. Other periods, the Neolithic and earlier, provide entirely different problems for the application of GIS systems.



Cartoon 5. ... and don't come back until you've found a cave with some statistical validity.

With respect to the environmental data used in this work we know from other studies that widespread erosion, degradation and deposition must have seriously affected the karst (Chapman et al. 1987, Sheil and Chapman 1988). Areas that now demonstrate severe erosion may have had greater soil cover in early periods. For the very earliest periods of human settlement on the island, rises in sea level between 8,000 and 5,500 B.C. will have resulted in the inundation of sites and landscape resources. Consequently we cannot hope that the modern environmental data adequately reflects the resources available on the island 9,000 years ago.

There are other problems, during these earlier periods. We are dealing with a human population with a radically different lifestyle to any that we can suggest as existing during, for example, the Roman periods. Even though there is increasing evidence that some form of agriculture was part of the lifestyle of the earliest Neolithic cultures on the Dalmatian coastline we cannot equate it with life on a Roman villa or even an Iron Age hillfort. The importance of other resources and activities including hunting and fishing cannot at the moment be entered into an analysis of this type.

When carrying out an analysis we must also acknowledge the problems caused by differential site preservation over the past seven millennia. The evidence for neolithic occupation on the island of Hvar is almost entirely restricted to material from caves or occasional isolated finds of stone artefacts. This does not mean that habitation was restricted to caves. Much settlement evidence must lie swamped below metres of redeposited soil within valley bottoms or even below the

present sea level. We must also be cautious in our interpretation of the sites we have available as occupation sites. They may have been only seasonally occupied or used for special purposes which may have had little to do with the everyday round of subsistence strategies.

Despite these massive problems, we decided to use the environmental and agricultural data available to us. During the survey of the Neolithic cave sites on the island we were struck by the unpromising nature of their environment. Although some sites eg Pokrivenik are associated with good soils and water resources other important sites including Markova and Grabceva spilja are on sites surrounded by land unusual for the extent of heavy erosion and with little or no good soils in the immediate vicinity. It was felt that it would be interesting to catchments for the cave sites with known neolithic occupation in order to find out whether this impression was correct. The distribution of the sites used in this analysis is shown in figure 53.



Figure 53. Neolithic cave sites on Hvar

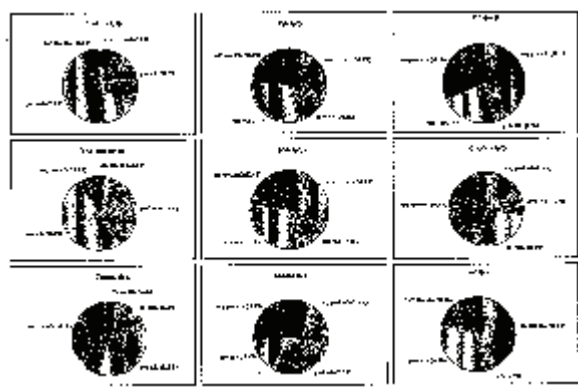

Figure 54. Soil types within neolithic cave site catchments (Click for larger image!)

The same procedure for producing catchments was followed here that was described above with the exception that the catchment was enlarged to a 10 km. equivalent on the assumption that the populations we were dealing with would have been far more mobile than in later periods. The data from these catchments is displayed in figure 54 as pie charts. The proportions of soil types within these diagrams contrast sharply with those from periods where relatively intensive agriculture is practised. The amount of good soil types within the catchment is much smaller and the overall proportions of soil types is similar to that for the whole island. This may simply be a consequence of the larger catchment size but it should not be discounted that it also reflects the more varied nature of the neolithic economy and the need to have a range of resources available within the catchment. The availability of resources is demonstrated in the detailed plans of the catchments for Vela and Markova spilja given in figures 55 and 56. These caves lie on eroded karst soils in land which was only fit for communal pasture during historic times. Despite the unpromising nature of the caves immediate environment, the flysch area, with some of the most fertile land on the island, falls within their catchments.

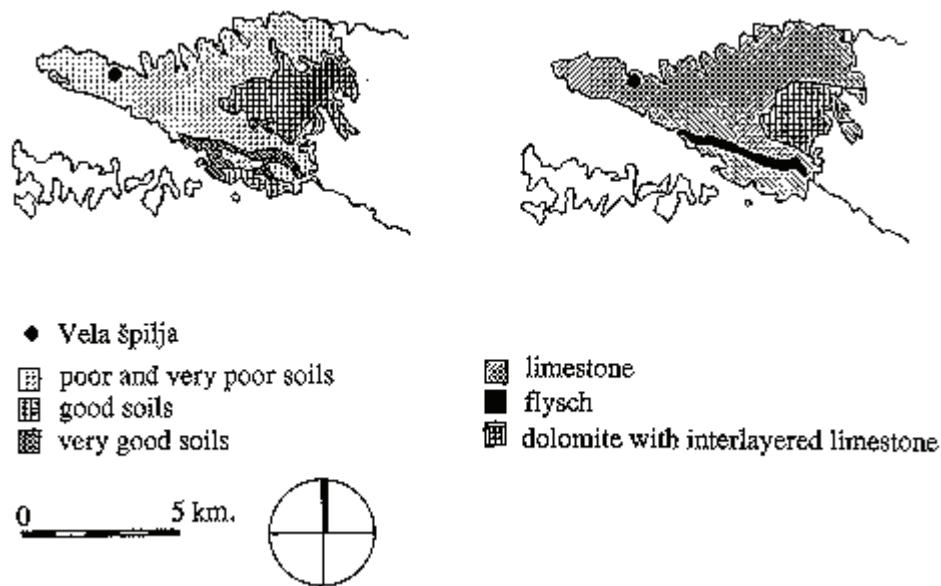

Figure 55. Soils and lithologies within the catchment of the cave site of Vela špilja

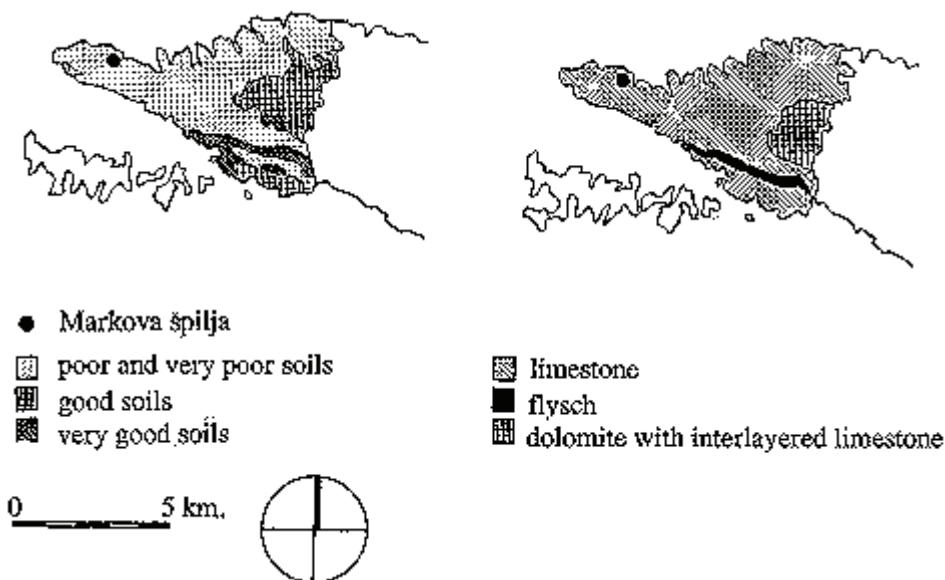

Figure 56. Soils and lithologies within the catchment of the cave site of Markova špilja

All the cave catchments are overlaid on the map of Hvar in figure 57. As we can see, the larger catchments cover the majority of the surface of the island. The only significant gaps in this distribution are in the central area of the island. The Southern part of this empty central area is very mountainous and is one of the most inhospitable areas of the island and we must assume that it was never very attractive for settlement. The Northerly part of this area is the Stari Grad plain one of the most attractive areas for settlement. The occasional finds of neolithic stone tools within the plain indicate that the land here was used in some way and we must suspect that the evidence for neolithic settlement on the plain lies buried beneath soil deposited during the later prehistoric to modern periods.

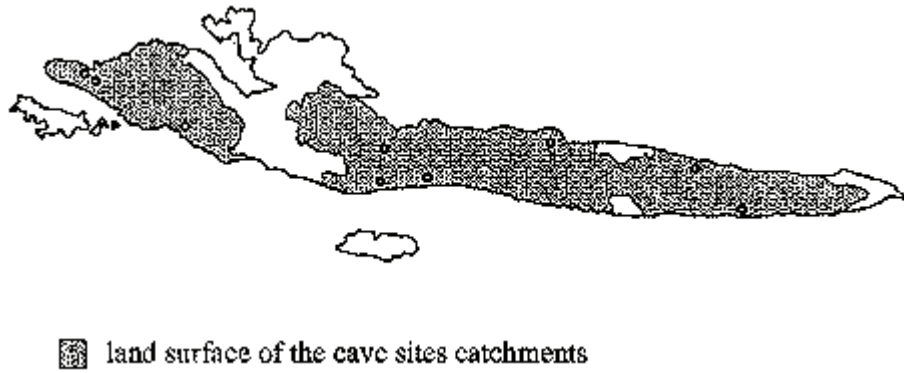

Figure 57. Land surface falling within the catchments of neolithic cave sites

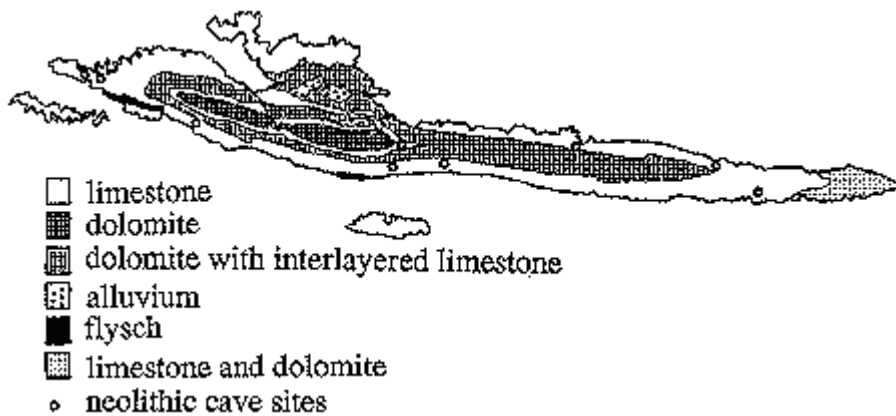

Figure 58. Neolithic cave sites and lithology on the island of Hvar

As a final somewhat flippant observation we might like to note the relationship between the neolithic cave sites and limestone illustrated in figure 58. The restriction of caves to the areas of limestone is of course an obvious one. Caves only form on the limestone therefore all the neolithic cave sites are found on limestone. If we run this through the GRASS statistical module we get the surprising result that there is no statistical relationship between limestone and neolithic cave sites. Truly as Mark Twain said there "lies, damned lies and (GIS) statistics".

10. GIS AND HERITAGE MANAGEMENT

The case studies presented in the previous chapters were largely carried out in order to demonstrate the use of GIS within the realms of archaeological research. However, one of the most important roles of GIS in the future will be as a cultural heritage management tool. The ability of GIS to incorporate archaeological data within modern environmental and development plans will allow a more accurate assessment of their impact on the cultural landscape. Within this process the spread of urban areas, transport networks and other destructive agents can be rapidly mapped and the consequences predicted.

The island of Hvar would certainly benefit from such an analysis (Carter 1990a, b). The rapid development of the tourist industry on the island has resulted in the increasingly rapid destruction of archaeological monuments on the island over the last twenty years, mainly as a result of the construction of hotel complexes and improvements to the island's infrastructure. The growth of tourism has also caused a notable increase in the decline of traditional lifestyles on the island. The relatively poor return from agriculture has resulted in a population movement towards the coastal areas in order to service the needs of the more profitable tourist industry. This process places even more pressure on the already weak infrastructure of the island and there is evidence that the island surpasses its carrying capacity during the summer season. In recent years this has resulted in the overloading of the sewage and water system and has led to major coastal pollution and salt contamination of drinking water supplies. Demographic change has also led to depopulation in those areas which do not participate in tourism (especially the central villages of the island) and the increasing abandonment of agricultural land. As a visitor travels around the island areas which used to be fields and vineyards are now being replaced by dense thorny undergrowth and almost impassable pine forest. It seems likely that many of the sites that we were able to visit during the course of the Hvar sites and monuments survey will be inaccessible to future archaeologists.

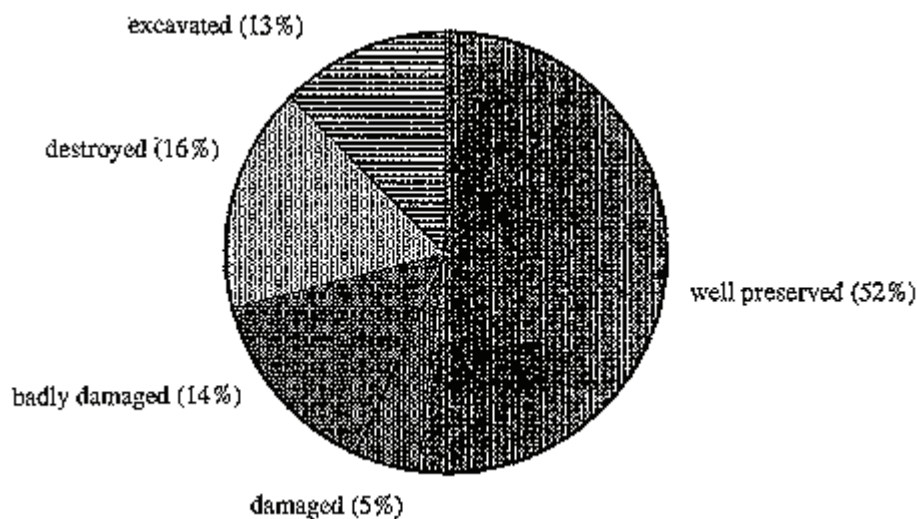

Figure 59. Levels of destruction on archaeological sites on Hvar

Unfortunately, data relating to the planned growth of the island was not available for incorporation in this study. Consequently we can only present the data on destruction of archaeological monuments held in the Sites and Monuments Register. This data is given in pie chart form in figure 59 and as a series of distribution maps in figures 60 to 63. The large amount of damage to archaeological sites on the island is very worrying, especially in the light of the very recent nature of much of the damage. It is also sad to admit that despite the availability of this data and the increasing awareness of the threat to the cultural monuments on the island the danger is increasing not diminishing. Increased expansion of the principal settlements on the island will almost certainly take place and several of the most sensitive archaeological areas will certainly be affected. There are plans to expand the town of Hvar to the North-West and around

the area of the Vira barrow cemetery (figure 37). Perhaps even more worrying are the existence of plans for the construction of an airport on the Stari Grad plain. Part of the plain has already been levelled prior to construction and has resulted in the destruction of several important Roman sites. The construction of even a small airport in this area with the provision of road, water and other services would undoubtedly result in massive destruction within one of the best preserved Greek colonial field systems now surviving in the Mediterranean.



Figure 60. Excavated sites on Hvar



Figure 61. Slightly damaged sites on Hvar



Figure 62. Badly damaged sites on Hvar



Figure 63. Totally destroyed sites on Hvar

In the past it has often been quite difficult to illustrate the results of development to the non-archaeologist. The ability of GIS systems to model changes in the environment and display them in an accessible visual format may be one of its most useful functions in the future. We hope that the application of such systems does not come too late for the antiquities of Hvar.

11. CONCLUDING COMMENTS

Although we have tried to make each section within this short monograph as self contained as possible, it is customary to end academic works with a few concluding remarks, and we would like to follow this fine tradition with a few comments of our own.

As this work goes to press, it is pleasing to note that there are several indications that GIS is moving from its previous status as a puzzling acronym to a subject of interested discussion amongst European archaeologists. Within Britain, the Theoretical Archaeological Group (TAG) conferences at Newcastle upon Tyne (1989) and Lampeter (1990) have contained GIS papers and sessions. Even more impressive is the 1991 Oxford Computer Applications in Archaeology (CAA) conference. The programme for which boasted no less than three sessions devoted to the subject and participants from Britain, America, Yugoslavia, the Netherlands, Austria, Japan and France. The wide range of potential GIS applications which could be demonstrated at such conferences would underline the value of GIS to archaeology and illustrate the fact that use of the technique is limited, to a large extent, only by our own imagination.

However, whilst such events are of great value for the dissemination of GIS techniques, they are far from commonplace. Success can only be claimed when the majority of field and academic archaeologists have access to such techniques on a day to day basis. It is our hope that the information provided here can contribute to this process. What more need be said? Only that we had great fun carrying out the Hvar pilot study and that we think that every archaeologist should have the opportunity to share that experience.

APPENDIX

CODES USED IN THE HVAR SITES AND MONUMENTS DATABASE

The value of a standardised approach to data collection is of critical importance to the application of GIS techniques. The comparative rarity of such work in Yugoslav archaeology makes a resume here of the archaeological database of some value. A complete description of all aspects of the project documentation system including intensive and extensive surface survey procedures will be published elsewhere (Gaffney forthcoming). It should be noted that the archaeological database was constructed before the possibility of GIS applications were considered. Some of the environmental variables that were recorded were made redundant by the better data provided by the Urban Institute of the Republic of Croatia in Zagreb.

1. Record Number e.g. HV0001.00

This figure is composed of two parts;

a) Map Area...Taken from the 1:5000 map sheet title.

BG - Bogomolje

HV - Hvar

JE - Jelsa

MI - Milna

NE - Nerezisce

SG - Stari Grad

VG - Vrgorac

VS - Vis

b) Site Number. A six figure number composed of a principal site number of four figures and a suffix of two figures used to denote sub-sites.

2. Fourteen figure grid reference taken from the 1:5000 map.

3. Height of site above or below sea level

4. Area of site in metres. In the case of tumuli and cairns the diameter of the mound was recorded.

5. The status of the site.

Y(es) The site is officially protected

N(o) The site is not protected

6. The preservation of the site;

1 Well preserved

2 Slightly damaged

3 Damaged

4 Destroyed

5 Excavated

7. Site toponym

8. Date of visitation

9. Details of field surveyors present.

10. Information on local informants.

11. Information on owner or tenant of land.

12. Type of remains. A ten figure code 000/000/000/0 The first nine figures refer to the type of site.

Funerary Monuments

005/000/000 Isolated cairn/tumulus
010/000/000 Isolated tumulus with grave
015/000/000 Barrow cemetery
000/020/000 Isolated grave (inhumation, no mound)
025/000/000 Inhumation cemetery
000/030/000 Isolated inhumation
000/035/000 Cremation cemetery
000/050/000 Stone setting/cist
000/055/000 Amphora/Pithos burial
000/060/000 Burial within tegulae
000/065/000 Gravestone
000/070/000 Sarcophagus
000/080/000 Internal chamber
000/090/000 Other internal architecture

Settlement Sites

105/000/000 Minor artefact scatter
110/000/000 Artefact scatter with no evidence for structures
115/000/000 Settlement with surviving structure but no defenses
120/000/000 Defended settlement
125/000/000 Cave with settlement evidence
130/000/000 Town
135/000/000 Urban domestic building/complex
150/000/000 Bath house

Isolated Portable Features

000/000/205 Pottery find
000/000/210 Stone find
000/000/215 Metal find
000/000/216 Stone and metal finds
000/000/217 Pottery and metal finds
000/000/220 Inscription
000/000/225 Coin find
000/000/230 Coin collection
000/000/235 Coin hoard
000/000/240 Other sculpture

Isolated Non-Portable or Settlement Features

Religious sites

305/000/000 Church
310/000/000 Shrine

Agricultural features

405/000/000 Field system
000/000/410 Oil or wine press
415/000/000 Linear clearance mound
000/420/000 Trim (agricultural field house)

Industrial/Semi Industrial Features

455/000/000 Lime kiln

Non-Settlement Defended Sites

505/000/000 Isolated tower

Isolated Water Sources

605/000/000 Well
000/610/000 Cistern

Miscellaneous

000/705/000 Wall
000/710/000 Estate boundary
000/715/000 Mosaic
000/720/000 Wall painting
000/730/000 Hypocaust
740/000/000 Excavation
745/000/000 Excavation trench
750/000/000 Unclassified

Maritime Sites

800/000/000 Unclassified maritime sites
805/000/000 Harbour
810/000/000 Anchorage site
815/000/000 Shipwreck
000/000/820 Isolated find
825/000/000 Cargo dump
000/000/830 Anchor
835/000/000 Aeroplane
000/000/840 Ships altar

The final part of the ten figure code refers to specific attributes of tumuli and hillfort sites.

Cairn attributes

1 Cairn composed of small stones
2 Cairn composed of mixed stone sizes
3 Cairn composed of large stones
4 Mound created with soil

Hillfort attributes

The lack of aerial photographic cover demanded that prehistoric settlements were divided subjectively into three sizes.

5 Small hillfort
6 Medium sized hillfort
7 Large hillfort

13. Chronological Periods

Palaeolithic 010.00

Mesolithic 020.00

Neolithic 030.00

Early Neolithic 030.05

Middle Neolithic 030.10

Late Neolithic 030.15

Eneolithic 040.00

Bronze Age 050.00

Early Bronze Age 050.05

Late Bronze Age 050.10

Iron Age 060.00

Early Iron Age 060.05

Late Iron Age 060.10

Prehistoric 065.00
 Greek 070.00
 Archaic 070.05
 8th century and earlier 070.10
 7th century 070.15
 6th century 070.20
 Classical 070.25
 5th century 070.30
 4th century 070.35
 late 4th - early 3rd 070.40
 Hellenistic 070.45
 3rd century 070.50
 2nd century 070.55
 later 2nd - early 1st century 070.60
 1st century 070.65
 Roman 080.00
 Early Roman 080.01
 late 1st cent.B.C.- early 1st A.D. 080.05
 Mid 1st century 080.10
 late 1st-early 2nd centuries 080.15
 2nd century 080.20 late 2nd - early 3rd centuries 080.25
 3rd century 080.30 late 3rd - early 4th centuries 080.35
 4th century 080.40
 Late Roman 080.45
 late 4th - early 5th centuries 080.50
 5th century 080.55
 late 5th - early 6th centuries 080.60
 6th century 080.65
 late 6th - early 7th centuries 080.70
 Early Medieval 090.00
 7th - 9th centuries 090.05
 10th - 12th centuries 090.10
 Medieval 100.00
 Renaissance/Venetian 110.00
 Pre-Industrial 120.00
 Modern 130.00
 Unknown 200.00

Whenever possible sites are assigned a primary period using the 5 figure codes listed above. All periods (the first three figures) present on site are recorded separately on a yes or no basis. This twofold division allows the chronological database to be searched more efficiently.

14. Slope

1 none-9%
 2 10%+
 3 20%+
 4 30%+

15. Erosion

1 none
 2 occasional rocks

3 up to 50% rock
4 over 50%

16. Terracing

The presence of terracing is recorded on a simple Yes or No basis.

17. Other damage to sites and knowledge of future threats is recorded as text description.

18. Topographical Position

Topographical position was recorded on a hypothetical position across a hill plain and onto the sea bed.

1 hilltop
2 slope
3 hill/plain interface
4 plain
5 stony and shallow shore
6 stone/sand interface
7 deep sandy base
8 sandy, shallow shore
9 stony, deep shore

19. Soil

Soil was recorded in the field using a simplified system devised for use on the karst by Sheil and Chapman (1988).

5 arable
10 stony
15 terrace
20 bottom land
25 steep karst
30 level karst

20. Wind

Exposure to specific types of wind can be a significant factor in settlement location in Dalmatia. Consequently, the dominant wind direction is recorded as N(orth), S(outh), W(est) and E(ast). Exposure to wind is recorded as Y(es) or N(o).

21. Currents

Where relevant and available the direction of the sea current was also recorded.

22. Land Use

10 scrub/brush
20 scrub and trees
30 scattered trees
40 forest
50 orchard
60 vineyard
70 pasture
80 arable
90 urban
100 other

23. Crops

10 fallow
20 cereals
30 fruit

40 citrus fruit
50 olives
60 lavender
70 vegetables
100 other

24. Field Records

Field notes are recorded as text description. Photographs taken on site and material collected is recorded as a simple Y(es) or N(o), detailed information being kept elsewhere.

25. Site History

Other information on the history of the site eg when discovered or excavated etc., are recorded as text description

26. Site Bibliography

Information on bibliographic references to individual sites was recorded as text data.

BIBLIOGRAPHY

- Allen K.M., Green S.W. and Zubrow E.B.W. (eds.), 1990. *Interpreting space: GIS and archaeology*. London.
- Altschul J.H., 1990. Red flag models: the use of modelling in management contexts. In Allen K.M.S., Green S.W. and Zubrow E.B.W. (eds.) *Interpreting space: GIS and archaeology*, London, pp. 226-238.
- The American Farmland Trust, 1985. *Survey of geographic information systems for natural resources decision making at the local level*. The American Farmland Trust. Washington D.C.
- Batovic S., 1984. Contribution aux etude de la ceramique corinthienne sur la cote orientale de l'adriatique. *Vjesnik za arheologiju i historiju dalmatinsku* 77, pp. 37-62.
- Bintliff J.L., 1977. *Natural environment and human settlement in prehistoric Greece*. British Archaeological Reports Supplementary Series 28.
- Bintliff J.L. and Gaffney V., 1988. The Ager Pharensis/Hvar project 1987. In Chapman J., Bintliff J., Gaffney V. and Slapsak B. (eds.) *Recent developments in Yugoslav Archaeology*. British Archaeological Reports International Series 431, pp. 151-175.
- Blakeman D.A., 1987. Some thoughts about GIS data-entry. *Proceedings of Second Annual International Conference, Exhibits and Workshops on Geographic Information Systems, San Francisco, Vol.1*, pp. 226-233.
- Bogunovic M. and Smanjak I., 1984. *Tla otoka Hvara. Projektni savjet za izradu pedoloske karte SR Hrvatske*, Zagreb.
- Bowden M.C.B. and McOmish D., 1987. The required barrier. *Scottish Archaeological Review* 4, part 2, pp. 76-84.
- Bowden M.C.B. and McOmish D., 1989. Little boxes: more about hillforts. *Scottish Archaeological Review* 6, pp. 12-16.
- Burrough P.A., 1986. *Principles of geographical information systems for land resources assesment*. Clarendon Press, Oxford.
- Carter F. W., 1990a. *Development of the Environment: a case study of Hvar Island, Yugoslavia*. Mediterranean Social Sciences Network. Newsletter 3, part 4, pp. 20-39.
- Carter F. W., 1990b. *Hvar Island Project: Report on the development of agriculture from its origins to the present*. Unpublished report.
- Chapman J. C., 1981. The value of Dalmatian museum collections to Dalmatian settlement studies. In Cantwell A.M., Griffin J.B. and Rothschild N.A. (eds.) *The research potential of Anthropological museum collections*. *Annals of New York Academy of Sciences*, 376, pp. 529-555.
- Chapman J.C., Shiel R. S. and Batovic S., 1987. Settlement patterns and land use in neothermal Dalmatia 1983-4. *Journal of Field Archaeology* 14, pp. 124-146.
- Clarke K.C., 1986. *Advances in geographic information systems. Computers, environment and urban systems*. Vol.10, pp. 175-184.
- Colwell R.N. (ed.), 1983. *Manual of remote sensing*. Second edition, American Society of Photogrammetry.
- Cowen D.J., 1987. GIS vs.CAD vs.DBMS: what are the differences? *Proceedings of Second Annual International Conference, Exhibits and Workshops on Geographic Information Systems, San Francisco, Vol.1*, pp. 46-56.
- Custer J.F., Eveleigh T., Klemas V. and Wells I., 1986. Application of LANDSAT data and synoptic remote sensing to predictive models for prehistoric archaeological sites: an example from the Delaware coastal plain. *American Antiquity*, Vol.51, pp. 572-588.
- Colak A., 1955. *Tla otoka Hvara*. Institut za jadranske kulture, Split.
- Day T. and Muller J.P.A.L., 1988. Quality assessment of digital elevation models produced by automatic stereo matchers from SPOT image pairs. *International Archives of Photogrammetry and Remote Sensing, Vol.27 (B3)*, pp. 148-159.
- De Atley S. P. and Findley F. J., 1984. *Exploring the limits: frontiers and boundaries in prehistory*. British Archaeological Reports International Series 223.
- Eastman J.R., 1988. *Grid-based microcomputer systems: a survey*. Paper presented at the Workshop on Grid-Based GIS systems, Canadian Cartographic Association.

- Evans H., 1989. The early medieval archaeology of Croatia AD 600-900. British Archaeological Reports Supplementary Series 539.
- Farley J., 1987. The land manager's dilemma: monitoring multidimensional resource associations in a three dimensional world. Proceedings of U.S.Army Corps of Engineers Sixth Remote Sensing Symposium, Galveston, Texas, pp. 198-218.
- Farley J.A., 1989. Integrating relational database capabilities with the GRASS geographic information management system. Proceedings of the 1988 Geographical Resource Analysis Support System (GRASS) User Group Meeting, USA CERL Technical Manuscript N-89/18, Champaign, Illinois, pp. 58-62.
- Farley J.A., Limp W.F. and Lockhart J., 1990. The archaeologist's workbench: integrating GIS, remote sensing, EDA and database management. In Allen K.M.S., Green S.W. and Zubrow E.B.W. (eds.) *Interpreting space: GIS and archaeology*, London, pp. 141-164.
- Gaffney V., forthcoming. The Hvar Project documentation manual. *Vjesnik za arheologiju i historiju dalmatinsku*.
- Gardels K., 1988. GRASS in the X-Windows environment distributing GIS data and technology. GIS/LIS'88 proceedings, San Antonio, Texas, Vol.2, pp. 751-758.
- Gill S.J. and Howes D., 1985. A geographic information system approach to the use of surface samples in intra-site distributional analysis. Paper presented at the International Symposium on Data Management and Mathematical Methods in Archaeology, International Union of Pre- and Protohistoric Sciences, Denver.
- Goran B.J., Westervelt J., Shapiro M. and Johnson M., 1987. GRASS users and programmers manual. U.S.Army Corps of Engineers, Construction Engineering Research Laboratory, USA CERL ADP Report N-87/22, Champaign, Illinois.
- Green S.W., 1990. Sorting out settlement in southeastern Ireland: landscape archaeology and geographic information systems. In Allen K.M.S., Green S.W. and Zubrow E.B.W. (eds.) *Interpreting space: GIS and archaeology*, London, pp. 356-363.
- Hamlin C.L., 1977. Machine processing of LANDSAT data: an introduction for anthropologists and archaeologists. *M.A.S.C.A Newsletter*, Vol.13, pp. 1-11.
- Harris T.M., 1986. Geographic information system design for archaeological site information retrieval. In Laflin S. (ed.) *Computer applications in archaeology 1986*, University of Birmingham, pp. 148-161.
- Harris T.M. and Lock G.R., 1990. The diffusion of a new technology: a perspective on the adoption of geographic information system within UK archaeology. In Allen K.M., Green S.W. and Zubrow E.B.W. (eds.) *Interpreting space: GIS and archaeology*, London, pp. 33-53.
- Hemans F.P., Myers J.W. and Wiseman J., 1987. Remote sensing from a tethered blimp in Greece. Technical paper No.2, Boston University Center for Remote Sensing.
- Herak M., Marincic S. and Polsak A., 1976. Geologija otoka Hvara. *Acta Geologica*, IX/1, J.A.Z.U., Zagreb.
- Kirigin B. and Popovic P., 1988. Maslinovik - a Greek watch tower in the chora of Pharos. A preliminary report. In Chapman J., Bintliff J., Gaffney V. and Slapsak B. (eds.) *Recent developments in Yugoslav Archaeology*. British Archaeological Reports International Series 431, pp. 177-189.
- Kirigin B. and Slapsak B., 1986. Starigradsko polje na otoku Hvaru. *Arheoloski Pregled* 1985, 26, pp. 207-208.
- Kovacic J., 1987. Iz Hvarske kulturne bastine. Hvar.
- Kovacic V., 1989. Stari Grad na otoku Hvaru. *Arheoloski Pregled* 1987, 28, pp. 85-86.
- Kvamme K.L., 1985. Determining empirical relationships between the natural environment and prehistoric site locations: a hunter-gatherer example. In Carr C. (ed.) *For Concordance in Archaeological Analyses*, Westport Publishers, pp. 208-238.
- Kvamme K.L., 1989. Geographic information systems in regional archaeological research and data management. In Schiffer M.B. (ed.) *Archaeological Method and Theory*, Vol.1, University of Arizona Press, Tucson, pp. 139-203.
- Kvamme K.L., 1990. GIS algorithms and their effects on regional archaeological analysis. In Allen K.M.S., Green S.W. and Zubrow E.B.W. (eds.) *Interpreting space: GIS and archaeology*, London, pp. 112-125.
- Limp W.F., 1987. The identification of archaeological site patterning through integration of remote sensing, geographic information systems and exploratory data analysis. Proceedings of U.S.Army Corps of Engineers Sixth Remote Sensing Symposium, Galveston, Texas, pp. 232-262.
- Lozar R.C. and Goran W.D., 1987. GRASS for military land use planning. *The Military Engineer*, pp. 468-469.

- Lyons T.R. and Scovill D.H., 1978. Non-destructive archaeology and remote sensing: a conceptual and methodological stance. In Lyons T.R. and Ebert J.I. (eds.) Remote sensing and non-destructive archaeology, National Park Service and University of New Mexico, Albuquerque, Publication no.36, pp. 3-19.
- Madry S.L.H., 1989. Geographic Resources Analysis Support System (GRASS), an integrated public domain GIS and image processing system. GIS/LIS'89 proceedings, Orlando, Florida, Vol.2, pp. 743-750.
- Madry S.L.H. and Crumley C.L., 1990. An application of remote sensing and GIS in a regional archaeological settlement pattern analysis: the Arroux River valley, Burgundy, France. In Allen K.M.S., Green S.W. and Zubrow E.B.W. (eds.) Interpreting space: GIS and archaeology, London, pp. 364-380.
- Makjanic B. and Volaric B., 1979. Prilog poznavanju klime otoka Hvara. J.A.Z.U. 383, Zagreb, pp. 273-344.
- Marovic I., 1985. Iskopavanje kamenih gomila u Bogomolju na otoku Hvaru. Vjesnik za arheologiju i historiju dalmatinsku 78, pp. 5-33.
- McRae S.D., 1989. GIS design and the questions users should be asking. Proceedings of GIS/LIS'89, Orlando, Florida, Vol.2, pp. 528-537.
- Meckley B., 1987. Determining your GIS requirements: the critical first step. Proceedings of the International Geographic Information Systems, Arlington, Virginia, Vol.3, pp. 257-269.
- Nikolanci M., 1958. Anticki spomenici otoka Hvara. Popis spomenika otoka Hvara, Split, pp. 49-58.
- Nikolanci M., 1977. Petar Nisiteo-Nisetic kao arheolog. Hvar u prirodnim znanostima, Zagreb, pp. 197-203.
- Novak G., 1955. Prehistorijski Hvar. Zagreb.
- Novak G., 1959a. Istrazivanje spilja Ormanice i Markove i gradine Gracisce na otoku Hvaru. Ljetopis J.A.Z.U. 63, Zagreb, pp. 319-325.
- Novak G., 1959b. Prehistorijske gomile na Paklenim otocima. Arheoloski radovi i rasprave 1, Zagreb, pp. 237-244.
- Novak G., 1972. Hvar kroz stoljeca. Zagreb.
- Otawa T., 1987. Accuracy of digitising: overlooked factor in GIS operations. Proceedings of Second Annual International Conference, Exhibits and Workshops on Geographic Information Systems, San Francisco, Vol.1, pp. 295-299.
- Parent P. and Church R., 1987. Evolution of geographic information systems as decision making tools. Proceedings of Second Annual International Conference, Exhibits and Workshops on Geographic Information Systems, San Francisco, Vol.1, pp. 63-71.
- Parker S., 1986. The role of geographic information systems in cultural resource management. In Opitz B.K. (ed.) Geographic information systems in government, Vol.1, Hampton, Virginia, pp. 133-140.
- Parker S.C., 1989. The design and implementation of an exploratory data analysis system (S-GEO) for integrating with GRASS, remote sensing and database management. Proceedings of the 1988 Geographical Resource Analysis Support System (GRASS) User Group Meeting, USACERL Technical Manuscript N-89/18, Champaign, Illinois, pp. 47-50.
- Parker H.D., 1989. GIS Software 1989: a survey and commentary. Photogrammetric Engineering and Remote Sensing 55, pp. 1589-1591.
- Peregrine P., 1988. Geographic information systems in archaeological research: prospects and problems. Proceedings of GIS/LIS'88, San Antonio, Texas, Vol.2, pp. 873-879.
- Perisset M.C. and Tabbagh A., 1981. Interpretation of thermal prospection on bare soils. Archaeometry, Vol.23, pp. 169-187.
- Petric M., 1986. Izvjestaj o arheolosko-konzervatorskim radovima na rusevini Gazarovic u Hvaru. Periodicni izvjestaj Centra za zastitu kulturne bastine komune Hvarske 156, pp. 7-17.
- Petric N., 1976. Arheoloske biljeske s Hvara. Hvarski Zbornik 4, pp. 217-226.
- Petric N., 1979. Hvarski tumuli. Vjesnik za arheologiju i historiju dalmatinsku 72-3, pp. 67-78.
- Ressler J.Q., 1989. The GRASS problem-solving manual. U.S.Army Corps of Engineers, Construction Engineering Research Laboratory, USA CERL ADP Report N-89/15, Champaign, Illinois.
- Sheil R. and Chapman J.C., 1988. The extent of change in the agricultural landscape of Dalmatia, Yugoslavia, as a result of 7,000 years of land management. In Chapman J., Bintliff J., Gaffney V. and Slapsak B. (eds.) Recent developments in Yugoslav Archaeology. British Archaeological Reports International Series 431, pp. 32-44.

- Stančić Z. and Slapsak B., 1988. A modular analysis of the field system of Pharos. In Chapman J., Bintliff J., Gaffney V. and Slapsak B. (eds.) *Recent developments in Yugoslav Archaeology, British Archaeological Reports International Series 431*, pp. 191-199.
- Quann J. and Bevan B., 1977. The pyramids from 900 kilometers. *M.A.S.C.A. Newsletter*, Vol.13, pp. 12-14.
- Tadic A., 1978. Jos ponesto o Grguru Bucicu. *Hvarski Zbornik* 6, pp. 209-226.
- V.A.H.D., 1986. Bulic: petnaest godina nakon smrti. *Vjesnik za arheologiju i historiju dalmatinsku* 79.
- Vita-Finzi C. and Higgs E.M., 1970. The prehistoric economy of the Mt. Carmel area. *Proceedings of the Prehistoric Society* 36, pp. 1-37.
- Wansleeben M., 1988. Geographic information systems in archaeological research. In Rahtz S.P.Q. (ed.) *Computer and quantitative methods in archaeology 1988, British Archaeological Reports International Series 446, Vol.2*, pp. 435-451.
- Warren R.E., 1990. Predictive modelling in archaeology: a primer. In Allen K.M.S., Green S.W. and Zubrow E.B.W. (eds.) *Interpreting space: GIS and archaeology*, London, pp. 90-111.
- Westervelt J., 1988. An introduction to GRASS. U.S.Army Construction Engineering Research Laboratory, Champaign, Illinois, pp. 1-11.
- Westervelt J., 1990. XGRASS Development - Draft II. U.S.Army Construction Engineering Research Laboratory, Champaign, Illinois, pp. 1-28.
- Williams I., Limp W.F. and Briuer F.L., 1990. Using geographic information systems and exploratory data analysis for archaeological site classification and analysis. In Allen K.M.S., Green S.W. and Zubrow E.B.W. (eds.) *Interpreting space: GIS and archaeology*, London, pp. 239-273.
- Zaninovic M., 1978a. Purkin Kuk kod Dola, Stari Grad, otok Hvar. *Arheoloski pregled* 20, pp. 47-51.
- Zaninovic M., 1978b. Novi prilozi arheoloskoj topografiji otoka Hvara. *Novija i neobjavljena istrazivanja u Dalmaciji, Vodice, Hrvatsko arheolosko drustvo*, pp. 49-62.
- Zaninovic M., 1981. Purkin Kuk, gradina kod Dola, otok Hvar. *Arheoloski pregled* 22, pp. 61-63.
- Zaninovic M., 1982. Nalazi sa Tora kod Jelse kao prilog njegovoj kronologiji. *Opuscula archaeologica* 7, pp. 61-76.
- Zaninovic M., 1987. Rimska villa rustica na Kupinoviku kraj Dola. *Prilozi povijesti otoka Hvara VIII*, pp. 91-96.