

Glacier forelands reveal fundamental plant and microbial controls on short-term ecosystem nitrogen retention

Franciska T. de Vries^{1,2}  | Cécile Thion^{3,4} | Michael Bahn^{5,6} | Benoît Bergk Pinto⁴ | Sébastien Cécillon⁴ | Beat Frey^{5,6} | Helen Grant⁷ | Graeme W. Nicol⁴ | Wolfgang Wanek⁸ | James I. Prosser³ | Richard D. Bardgett² 

¹Institute for Biodiversity and Ecosystem Dynamics, University of Amsterdam, Amsterdam, The Netherlands; ²Department of Earth and Environmental Sciences, Michael Smith Building, The University of Manchester, Manchester, UK; ³School of Biological Sciences, University of Aberdeen, Aberdeen, UK; ⁴Laboratoire Ampère, École Centrale de Lyon, Université de Lyon, Ecully, France; ⁵Department of Ecology, University of Innsbruck, Innsbruck, Austria; ⁶Rhizosphere Processes Group, Swiss Federal Research Institute WSL, Birmensdorf, Switzerland; ⁷UK Centre for Ecology and Hydrology, Lancaster, UK and ⁸Department of Microbiology and Ecosystem Science, Center of Microbiology and Environmental Systems Science, University of Vienna, Vienna, Austria

Correspondence

Franciska T. de Vries
Email: f.t.devries@uva.nl

Funding information

British Ecological Society; NERC Life Sciences Mass Spectrometry Steering Committee Grant, Grant/Award Number: NE/L006286/1; BBSRC David Phillips Fellowship, Grant/Award Number: BB/L02456X/1; AXA Research Fund; EU Horizon 2020, Grant/Award Number: ITN 675546

Handling Editor: David Armitage

Abstract

1. Human activities have massively increased the amount of reactive nitrogen in the biosphere, which is leading to increased nitrogen (N) inputs in terrestrial ecosystems. The retention of N is a crucial ecosystem function of both managed and natural ecosystems, and there is a long history of experimental, observational, and conceptual studies identifying its major controls. Yet, the plant and soil microbial controls on the retention of added N remain elusive.
2. Here, we used three ecosystem chronosequences in front of retreating glaciers in the European Alps to test our hypothesis that the retention of added reactive ¹⁵N increases as succession proceeds, and to identify the plant and microbial controls on ecosystem N retention.
3. We found that the uptake and retention of N did not change during succession, despite consistent changes in plant, soil, and microbial properties with increasing time since deglaciation. Instead, we found that plant and microbial properties that remained constant during succession controlled ¹⁵N uptake and retention: low root and microbial C/N ratios, as well as high root biomass, increased plant and microbial uptake of added N. In addition, high soil concentrations of nitrate and ammonium reduced the uptake of N in microbes and roots, respectively.
4. *Synthesis.* Our results demonstrate that plant and microbial N demand, as well as soil N availability, drive the short-term retention of added N during succession in glacier forelands. This finding represents an advance in our understanding of the fundamental controls on ecosystem N retention and the role of plant-microbial interactions in this process. Such understanding is crucial for predicting and

This is an open access article under the terms of the Creative Commons Attribution License, which permits use, distribution and reproduction in any medium, provided the original work is properly cited.

© 2021 The Authors. *Journal of Ecology* published by John Wiley & Sons Ltd on behalf of British Ecological Society

mitigating the response of terrestrial ecosystems to the ever-increasing amounts of reactive N in the biosphere.

KEYWORDS

carbon, glacier foreland, global change, nitrogen, nitrogen deposition, plant-soil interactions, soil microbial community, succession

1 | INTRODUCTION

Nitrogen (N) retention is a fundamental and important ecosystem function, particularly in the face of global nitrogen enrichment. The ability of terrestrial ecosystems to retain reactive N is an indicator of the extent to which they are N-limited, as well as a key property of natural and managed ecosystems, where it regulates N losses that cause eutrophication of aquatic ecosystems and exacerbate climate change (Schlesinger, 2009). Ecosystem N retention and its counterpart N loss are regulated by both abiotic factors, such as parent material and climate, and biotic factors, such as plant and soil microbial properties (Templer et al., 2012). While many empirical and theoretical studies have examined the role of plant and soil properties, and their nutrient stoichiometry, in regulating ecosystem N retention, our understanding of the underpinning mechanisms remains elusive. In particular, despite widespread acknowledgement of the importance of soil microbes in immobilising reactive N and reducing ecosystem N leaching losses, it is still unresolved which soil microbial community attributes are responsible for regulating ecosystem N retention, and how these are linked to plant communities and soil physicochemical properties (Lajtha, 2019).

Early studies on terrestrial ecosystem N retention demonstrated that old-growth forests have much larger N-leaching losses than early-successional forests (Vitousek & Reiners, 1975). This work led to the classic conceptual model of Vitousek and Reiners, who proposed that actively growing plants in early to mid-successional ecosystems have high rates of N uptake, and, as such, these systems have high N retention (Vitousek & Reiners, 1975). In contrast, late-successional systems, with slower plant growth and biomass accumulation dominated by mature trees or plant communities consisting of slow-growing species, are more 'leaky' of N. However, many observational studies do not support this classic model (Lajtha, 2019; Lovett et al., 2018). Recent work, for instance, has shown that ecosystems can differ strongly in their retention of reactive N and that soil, litter, and microbial biomass pools retain more N than aboveground plant biomass on relatively short timescales, and are thus more important controls on initial ecosystem N retention than plant N uptake (Templer et al., 2012). After rapid immobilisation by microbes, N is gradually released through microbial turnover and subsequently taken up by roots and translocated to aboveground biomass (De Vries, Bloem, et al., 2012; Harrison et al., 2007). While the accumulation of soil organic matter and higher C/N ratios of soil and litter have been linked to greater ecosystem N retention through increased microbial N immobilisation (Lajtha, 2019; Lovett

et al., 2018; Vitousek & Matson, 1985), the microbial community attributes associated with these changes are poorly understood.

Recent studies have demonstrated the importance of interactions between plants and soil microbial communities in determining ecosystem N uptake and retention. For example, field studies in temperate grasslands show that N retention is greatest, and N leaching losses lowest, in grasslands characterised by plant communities dominated by slow-growing, nutrient-conservative species, and soil microbial communities dominated by fungi (Bardgett et al., 2003; De Vries, Bloem, et al., 2012; De Vries et al., 2006; Grigulis et al., 2013). The general mechanism underpinning this observation is that soils of low N availability select for N-conservative plant species and fungal-dominated microbial communities (De Vries, Manning, et al., 2012), which compete for and immobilise significant amounts of N, thereby enhancing N retention (De Vries, Bloem, et al., 2012). Moreover, N-conservative plant species and fungi have slower growth and lower turnover rates than fast-growing plants and bacteria, and thus the N taken up in their tissues is retained for longer, again reducing the availability and mineralisation of N in the soil (De Vries, Bloem, et al., 2012). At the same time, common garden and laboratory experiments have shown that fast-growing plant species and bacteria-dominated microbial communities have the highest N uptake and retention (De Vries & Bardgett, 2016; Grassein et al., 2015; Myrold & Posavatz, 2007), potentially indicating that different mechanisms might underlie ecosystem N retention under controlled conditions compared to field conditions. In particular, under field conditions, other factors than plant and microbial N uptake rates might explain ecosystem N retention, such as high soil C stocks and soil C/N ratios (Manning et al., 2015), with reduced availability of N for plant and microbial uptake. Under such conditions, plants might employ other strategies to acquire their nitrogen, for example reducing the availability of N by releasing polyphenols, and by taking up organic N forms directly or through associations with mycorrhizal fungi (Northup et al., 1995; Wurzbürger & Hendrick, 2009). Thus, the factors affecting ecosystem N retention are complex and highly interlinked, which complicates identifying the plant and microbial properties that underlie increased ecosystem N retention in the real world.

Glacier forelands are excellent model systems for studying how fundamental ecological processes change during ecosystem succession, and studies of these systems have led to major advances in our understanding of the role of plant-soil interactions in ecosystem development (Chapin et al., 1994; Crocker & Major, 1955; Walker et al., 2010). As glaciers retreat, they expose barren parent material,

which is then colonised by microbes and plants and undergoes primary succession, thus creating a successional gradient with increasing distance from the glacier front. These space-for-time substitutions show predictable changes with increasing distance from the glacier forefront: plant and soil microbial biomass increase, soil organic C and N accumulate, and microbial communities become more dominated by fungi (Bernasconi et al., 2011; Ohtonen et al., 1999; Tscherko et al., 2003). In line with the increase in soil C and N with time since deglaciation, the abundances of N-cycling genes related to the decomposition of organic material (Zeng et al., 2016) and ammonia oxidation (Brankatschk et al., 2011) increase, while those of genes involved in denitrification decreases (Brankatschk et al., 2011; Kandeler et al., 2006). Moreover, while vegetation in the early stages of glacier foreland sites is limited by N and in later stages by P (Chapin et al., 1994), findings on nutrient limitation of soil microbes are inconsistent and seem to depend on variations in soil properties within and between glacier forelands (Castle et al., 2017; Göransson et al., 2011; Yoshitake et al., 2007). Thus, these systems provide a unique opportunity to study how ecosystem N retention changes during primary succession, while at the same time displaying enough variation within successional stages to identify the major plant and microbial controls of ecosystem N uptake and retention (Bradley et al., 2014; Walker et al., 2010).

Here, we aimed to identify the fundamental plant and microbial controls on the ecosystem uptake and retention of added N using three geographically distinct glacier forelands in the European Alps as a model system. We hypothesised that the retention of added N increases during succession as a result of increased abundance of slow-growing, N conservative plants, which associate with fungal-dominated soil microbial communities, and the build-up of soil organic matter as soils age. Specifically, we hypothesised that plant communities dominated by N-conservative species would select for N-conservative microbial communities, which, together with an increase in soil C/N ratio, would increase microbial immobilisation of added N and decrease N leaching losses. We also aimed to link the microbial uptake of added N to changes in bacterial community composition, in particular to changes in the abundance of soil fungi, bacteria and ammonia-oxidising archaea and bacteria, which play a key role in nitrification. This was achieved by adding ^{15}N -labelled inorganic N to intact soil cores collected from five successional stages of increasing soil age (with average ages of 16, 38, 60, 112 and 157 years) and one reference site (deglaciated around 2,000 years ago) in three well-documented, geographically distinct glacier forelands in the European Alps, and assessing the short-term fate of this added N after a simulated rainfall event.

2 | MATERIALS AND METHODS

2.1 | Sample collection

Soil was collected in September 2012 in three geographically distinct glacier forelands located in Ödenwinkelkees (Austria,

47°12'E, 12°64'N, 2,060–2,161 m altitude), Rotmoosferner (Austria, 46°83'E, 11°04'N, >2,296 m altitude; Philippot et al., 2011) and Damma (Switzerland, 46°64'E, 8°46'N, 1,939–2,050 m altitude; Bernasconi et al., 2011). Mean annual temperatures are 0.2 ± 0.6 , -1.0 ± 0.5 and $2.2 \pm 0.5^\circ\text{C}$ and mean annual precipitation $2,258 \pm 665$ mm, 904 ± 150 mm and $2,400 \pm 385$ mm for the Ödenwinkelkees, Rotmoosferner and Damma, respectively (Bernasconi et al., 2011; Kaufmann, 2001; Tscherko et al., 2003). Intact soil cores (6.4 cm diam., 15 cm depth, vegetation intact, bottom covered with mesh) and adjacent vegetation and soil samples ('field soil' hereafter, 15 cm depth) were collected from five transects at each site, at distances from the glacier forefront corresponding to an average time since deglaciation of 16, 38, 60, 112 and 157 years (exact ages of the sites sampled were 15, 40, 59, 112 and 156 years for Ödenwinkelkees, 17, 37, 59, 112 and 162 for Rotmoosferner, and 17, 37, 62, 112 and 152 years for Damma; see Figure 1 for details on sampling and Table S1 for details on botanical composition), as well as from plots located in each glacial valley but outside the foreland *sensu stricto* (i.e. these plots were never covered by the glacier), and deglaciated more than 1,000 year ago (reference soils; Bernasconi et al., 2011; Kaufmann, 2001; Tscherko et al., 2003). Intact soil cores are an intermediate between field-based studies and glasshouse-based common garden experiments, and have been proven effective in studies for ^{15}N and ^{13}C -tracing experiments (De Vries, Bloem, et al., 2012; Wang et al., 2021). The size of the intact cores used reflected the depth of the soil across glacier forelands and captured the main zone of plant and microbial control on uptake and retention of added N, and within-site variation was captured by the five replicates we took at each site (Bernasconi et al., 2011; Tscherko et al., 2003). In total, this resulted in five replicates for each of five successional stages, plus one reference site for each glacier, i.e. 90 sample units. Soils (not intact cores) were sieved to 4 mm, shipped overnight in cool boxes to The University of Manchester (UK), and stored at 4°C until further analysis. Intact cores and collected vegetation were shipped and stored under the same conditions until the start of the ^{15}N addition experiment and vegetation sample processing.

2.2 | ^{15}N addition experiment

After shipping, intact cores (with vegetation intact) were placed in controlled growth chambers (Percival USA, 9°C , which is the average September temperature at the sites, 8 hr/16 hr day/night cycle, at constant moisture content) in a randomised block design and left to acclimatise for one week. Thereafter 4×1 ml of a 0.05 M 98.2% enriched $^{15}\text{NH}_4^{15}\text{NO}_3$ solution was injected in the top 5 cm of each soil core in 4 evenly spaced locations (total of 6.43 mg ^{15}N per core, equivalent to 20 kg N/ha or 2 g/m²). Forty-eight hours after ^{15}N injection, the cores were leached with 97 ml demineralised water (equivalent to a 30 mm rainfall event). Past work has shown that the amount retained in the system 48 hr

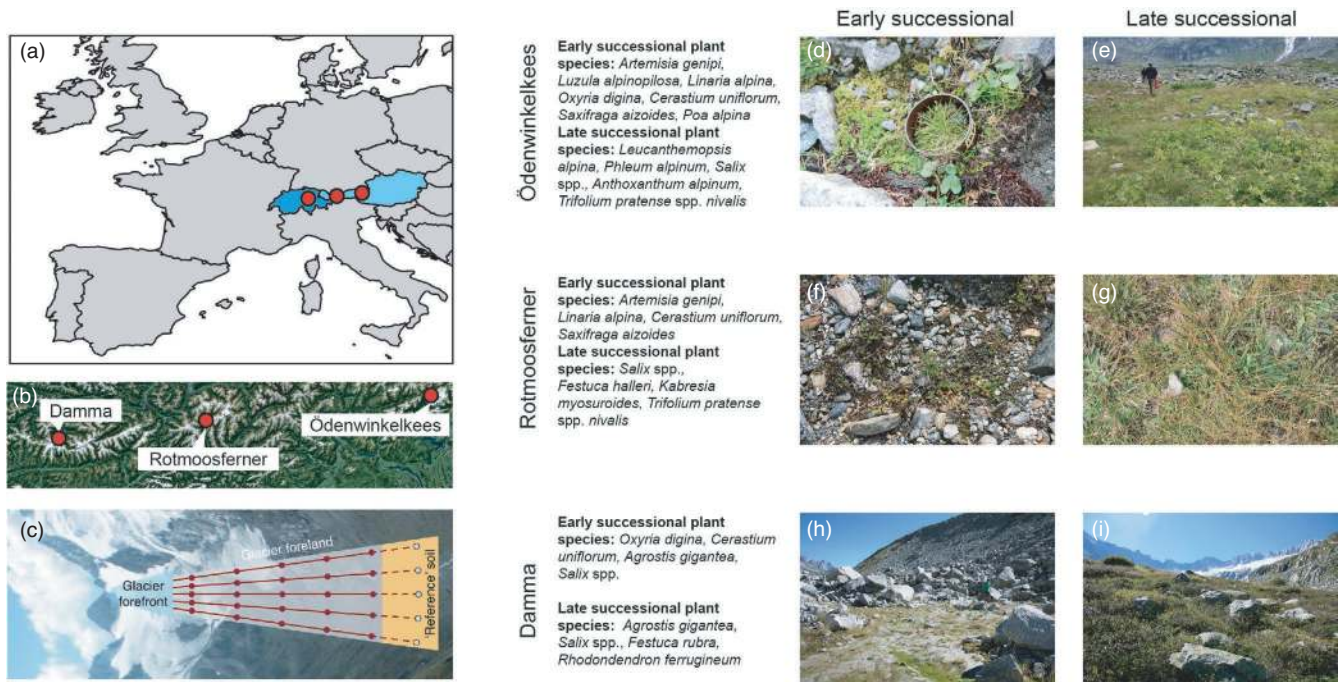

FIGURE 1 Overview of sampling scheme, sites, and site characteristics. Three glacier forelands were sampled, Damma in Switzerland (light blue) and Rotmoosferner and Ödenwinkelkees in Austria (light blue) (a), representing a west-east gradient in the Alps (b). In each glacier foreland, five samples were taken from five different locations in front of the glacier and one reference site (c). Early successional sites close to the glacier forefront were characterised by sparse cover of pioneer species (d, f, h), while late successional sites had dense cover of grasses and shrubs (e, g, i). For detailed botanical composition see Table S1

after ^{15}N addition is a good indicator of longer-term ecosystem N retention (De Vries, Bloem, et al., 2012). After leaching, the cores were dismantled, and soil and aboveground and belowground vegetation were separated, and the volume of leachates recorded.

2.3 | Leachate, soil and vegetation analyses

Gravimetric soil moisture contents of core and field soils were determined by drying for 24 hr at 105°C , and for the core soils with recorded weight and volume of stones larger than 4 mm, used to determine core bulk density and fine soil (all material <4 mm) content. Leachates and field soil were analysed for dissolved inorganic and organic nitrogen (DON) and dissolved organic C (DOC) as described in De Vries, Bloem, et al. (2012). Microbial biomass C and N in field soil and column soil were determined by chloroform-fumigation extraction as described by Brookes et al. (1985). Root and shoot biomass from field samples and intact cores were separated, weighed, dried (60°C for 48 hr), weighed again and analysed for total C and N on an Elementar Vario EL elemental analyser. Dried and ground field and core soil samples were also analysed for total C and N on the Elementar Vario EL elemental analyser. Leachates and microbial extracts from soil cores (enriched in ^{15}N) and field soil (natural abundance of ^{15}N) were freeze-dried, and, with dried and ground root, shoot, and soil material from both cores and field samples, analysed for $^{15}\text{N}/^{14}\text{N}$

ratios at the Life Sciences Mass Spectrometry Facility, Lancaster node, CEH Lancaster. Enough sample to provide as near as possible to $84\ \mu\text{g}$ elemental nitrogen was weighed (based on total N contents as measured on the Elementar Vario EL elemental analyser, see above) using a high precision micro-balance, (Sartorius Ltd) and then sealed into a 6×4 mm tin capsule. Samples were then combusted using an automated Carlo Erba NA1500 elemental analyser (Carlo Erba, part of Thermo Scientific, USA) coupled to a Dennis Leigh Technology Isotope Ratio Mass-Spectrometer (Dennis Leigh Technologies). A working standard of n-carbobenzyloxy-l-aspartic acid (CBA—Sigma-Aldrich Co. Ltd.) which is calibrated against the certified reference material IAEA-N1 (Ammonium sulphate—NIST number 8547; Bureau of Analysed Samples Ltd) was analysed after every 12th sample resulting in an analytical precision of 0.63‰ for the natural abundance samples. Results are expressed in δ notation; i.e. $\delta^{15}\text{N} = [(R_{\text{sample}} - R_{\text{standard}})/R_{\text{standard}}] \times 1,000$ (‰) where R is the ratio of ^{15}N to ^{14}N in the sample and standard, accordingly. All $\delta^{15}\text{N}$ results are expressed relative to the international standard of atmospheric air. $\delta^{15}\text{N}$ values from ^{15}N enriched (core soil) and natural abundance (field soil) samples were then used to calculate ^{15}N excess atom percent values in the ^{15}N enriched samples, after which total amounts of ^{15}N in ecosystem pools (microbial biomass, shoots, roots, soil, and leachates) were calculated using their total N pool sizes, which were then scaled to g/m^2 using the bulk density and the surface area of the cores. ^{15}N retention was calculated as the sum of ^{15}N in soil, microbial biomass, and aboveground and belowground vegetation.

2.4 | DNA extraction, qPCR, preparation of amplicons, and sequencing

Nucleic acids were extracted from 0.5 g field soil as previously described (Griffiths et al., 2000) with modifications (Nicol et al., 2005) and raw extracts were stored at -20°C . The abundances of fungi, bacteria and ammonia oxidising archaea and bacteria were estimated by real-time quantitative PCR (qPCR). Fungal abundance was assessed using 18S ribosomal gene primers (Fung5F and FF390R; Lueders et al., 2004; Lueders et al., 2004) rather than the ITS region to avoid potential bias from the variable length of ITS amplicons. Bacterial abundance was assessed using 16S rRNA gene primers 968F/1401R (Felske et al., 1998). Archaeal and bacterial ammonia oxidiser abundances were assessed using *amoA* primers Crenamo23F/Crenamo616R (Tournu et al., 2008) and *amo1F/amo2R* (Rotthauwe et al., 1997), respectively. Illumina paired-end sequencing of the hypervariable V3-V4 region of bacterial 16S rRNA

gene amplicons was performed at the Centre for Genome-Enabled Biology and Medicine (Aberdeen, UK). DNA quantity, measured fluorometrically using the Qubit dsDNA BR Assay Kit (ThermoFisher, UK), increased with soil age and varied from 1.3 to 190 ng/g soil (Table 1; Table S5). We removed samples with <5 ng DNA; for each of the remaining samples, PCR (25 cycles each) was performed using 5 ng template DNA, using the forward and reverse primer sequences 5'-CCTACGGGNGGCWGCAG-3' (S-D-Bact-0341-b-S-17) and 5'-GACTACHVGGGTATCTAATCC-3' (S-D-Bact-0785-a-A-21; Klindworth et al., 2013) and Illumina overhang adapters 5'-TCGTCGGCAGCGTCAGATGTGTATAAGAGACAG-3' and 5'-GTCTCGTGGCTCGGAGATGTGTATAAGAGACAG-3', respectively. Replicate amplification products were pooled and processed with AMPure purification system (Agencourt Bioscience Corporation, US). Pure pooled amplicons were then indexed with 8 PCR cycles and fragment size determined on a 2200 TapeStation (Agilent, Germany). Equimolar concentrations of samples were pooled and sequenced on

TABLE 1 ANOVA table of lme models for the effect of soil age, glacier, and their interaction, on soil, plant and microbial properties. Significant effects ($p < 0.05$) are highlighted in bold, significant trends ($p > 0.1$) in italics

	Soil age		Direction of change with soil age	Glacier		Glacier \times soil age	
	$F_{1,9}$	p		$F_{2,9}$	p	$F_{2,9}$	p
Soil moisture (g/g)	0.96	0.353		1.04	0.391	0.62	0.559
Soil pH	21.75	<0.0001	↓	65.04	<0.0001	2.69	0.121
Soil C (g/m ²)	16.18	0.003	↑	4.12	0.054	2.15	0.172
Soil N (g/m ²)	31.30	0.0003	↑	1.74	0.229	1.20	0.345
Soil C/N	0.76	0.405		1.51	0.273	0.31	0.739
NH ₄ ⁺ concentration (g/m ²)	0.66	0.439		3.98	0.058	1.58	0.258
NO ₃ ⁻ concentration (g/m ²)	1.67	0.229		1.89	0.207	1.68	0.240
DON concentration (g/m ²)	1.33	0.279		0.04	0.957	1.21	0.341
DOC concentration (g/m ²)	15.86	0.003	↑	0.41	0.675	0.12	0.884
Shoot biomass (g/m ²)	3.15	0.110		1.09	0.377	1.27	0.327
Root biomass (g/m ²)	3.51	0.093	(↑)	2.17	0.170	0.31	0.738
Shoot N (g/m ²)	1.39	0.267		0.45	0.652	1.49	0.276
Root N (g/m ²)	10.10	0.011	↑	2.12	0.176	1.90	0.205
Shoot C/N	0.75	0.409		0.22	0.808	0.74	0.505
Root C/N	1.17	0.307		2.32	0.153	0.28	0.760
Microbial biomass C (g/m ²)	25.39	0.0007	↑	1.70	0.236	0.05	0.946
Microbial biomass N (g/m ²)	10.46	0.010	↑	1.97	0.196	0.04	0.965
Microbial C/N	1.39	0.267		1.15	0.358	0.24	0.793
DNA (ng/m ²)	6.57	0.031	↑	0.60	0.571	0.26	0.778
16S (gene copies m ⁻²)	20.78	0.001	↑	0.09	0.910	0.13	0.880
18S (gene copies/m ²)	18.98	0.002	↑	0.64	0.548	0.28	0.765
18S/16S	1.39	0.269		6.02	0.022	2.30	0.156
AOA (gene copies/m ²)	48.21	0.0001	↑	7.94	0.010	3.70	0.067
AOB (gene copies/m ²)	2.58	0.147		15.02	0.002	0.90	0.446
AOA/AOB	14.41	0.009	↑	0.21	0.819	0.37	0.707

an Illumina MiSeq sequencer with V2 2 × 250 bp paired-end chemistry including PhiX Control V3 (Illumina, US) and generated 7,576,266 quality-checked reads.

2.5 | Sequence cleaning and clustering

Sequence analysis was performed using a custom pipeline. Briefly, Illumina-generated forward and reverse reads were first paired using the *PANDAseq* Assembler and trimmed to remove primer sequences (Masella et al., 2012). Trimmed assembled sequences were dereplicated by de novo clustering at 97% similarity (Edgar, 2010) and remaining singletons (1 read in the total dataset) were removed. This generated 14,622 OTUs, with an average of 68,000 reads per sample. Average read number increased significantly with soil age (from 38,909 ± 7,129 to 76,545 ± 9,350). Read numbers in five samples of young soils were very low (<4,632) and were discarded from the analysis. A reference V3–V4 database was generated by performing in silico PCR on the SILVA 115 database with the same set of primers using the *TaxMan* webserver (Brandt et al., 2012). Double-annotated sequences and sequences with no species annotation were removed from the database, leading to a reference sequence set containing 172,576 unique, fully annotated sequences. Taxonomic assignment was achieved by clustering the 14,622 representative sequences against the reference database using the *Uclust* algorithm (Edgar, 2010) in combination with a custom Linux script considering all possible hits at 97% similarity, dividing the number of reads of each OTU in a sample by the number of potential hit sequences, to distribute the uncertainty of the annotation. OTU number was used as measure of bacterial richness, Shannon diversity as a measure of diversity that includes the evenness of OTU abundance, and the Gini coefficient as a measure of dispersion of OTUs within a community, with values of zero representing perfect equality. These measures were computed by custom R scripts using the *VEGAN* (Oksanen et al., 2017) and *INEQ* (Zeileis, 2014) packages.

2.6 | Statistical analyses

All variables were scaled to g/m² using the bulk density, stone content, and area of the intact cores. All statistical analyses were done in R version 3.5.2 (R Core Team, 2018) and all data were checked for normality and log-transformed where necessary. The effect of individual glacier and time since deglaciation (soil age, this excluded the never-glaciated Reference sites), and their interaction, on soil, vegetation, microbial properties, and ¹⁵N pools was tested using linear mixed effects models with an error term for block to account for the non-independence of the five replicate samples per soil age. This was done using the function *lme* in the R package *NLME* (Pinheiro et al., 2020). Differences in bacterial community composition between the glacier forelands and across soil ages were visualised through principal coordinates analysis (PCoA) of OTUs based on

(weighted and unweighted) Bray–Curtis distances, using the *vegdist* and *cmdscale* functions in the package *VEGAN* (Oksanen et al., 2017). The effect of glacier foreland and soil age on bacterial community composition was assessed by a PERMANOVA using the function *adonis* (1,000 permutations). PCoA scores of bacterial community composition were used in subsequent analyses to explain ¹⁵N uptake and retention in ecosystem N pools.

We used a manual model selection procedure, again using the *lme* function in *NLME*, to identify the main drivers of ¹⁵N uptake in, and enrichment of, individual ecosystem N pools, entering terms individually first, retaining significant terms, and testing them in combination and in interaction, following De Vries, Manning, et al. (2012). In these models, an error term was included where soil age (including Reference sites) was nested in glacier. Model selection was done based on AIC using maximum likelihood estimation and the final most parsimonious model was run using restricted maximum likelihood estimation. Finally, structural equation modelling was done using the package *PIECEWISESEM* (Lefcheck, 2016), and regressions included an error term of soil age (including Reference sites) nested in glacier (as above). Model fit was assessed using Fisher's C statistic.

3 | RESULTS

3.1 | Soil and plant properties

Measured soil properties changed predictably during succession across the three glacier forelands. Soil pH decreased with soil age, while total soil C and N stocks and dissolved organic C (DOC) concentration increased (Table 1; Table S2). In contrast, soil C/N ratio and the availability of inorganic (NH₄⁺ and NO₃⁻) and organic (DON) N forms did not change significantly with soil age. Of the plant properties measured, only root N increased significantly with soil age. Other than soil pH, which was overall lowest in the Damma and highest in the Rotmoosferner glacier foreland, none of the soil and plant properties differed between the three glacier forelands (Table 1; Tables S2 and S3).

3.2 | Microbial communities

Microbial community properties showed strong and consistent changes as succession proceeds across the three glacier forelands. Microbial biomass C and N, the total amount of soil DNA, bacterial (16S rRNA), fungal (18S rRNA), and ammonia-oxidising archaea (AOA) gene abundances (assessed using qPCR) all increased with soil age (Table 1; Tables S4 and S5). While the fungal-to-bacterial gene abundance ratio did not change, the ratio of ammonia-oxidising archaea to ammonia-oxidising bacteria (AOB) increased with soil age.

The first two axes of PCoA explained 33.5% and 9.7% of variation in bacterial community composition, respectively (Figure 2) (unweighted PCoA—based on presence-absence—was very similar (Figure S1). PCoA clearly discriminated young soils from the

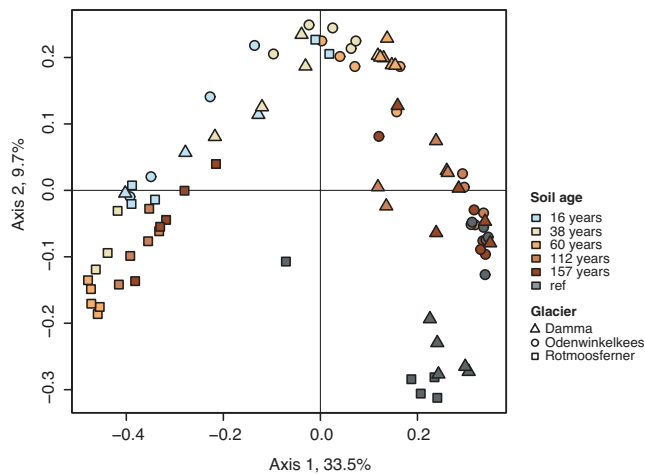

FIGURE 2 PCoA plot of bacterial community composition as affected by soil age and glacier. Bacterial community composition was affected by glacier, soil age, and their interaction (PERMANOVA, main effect for glacier $F_{2,67} = 18.74$, $p < 0.001$; main effect for soil age $F_{5,67} = 9.27$, $p < 0.001$; interaction effect $F_{10,67} = 4.64$, $p < 0.001$)

oldest for both the Damma and Ödenwinkelkees glacier forelands. Bacterial community composition also changed with soil age in the Rotmoosferner glacier foreland, but here discrimination was less marked, although reference soils clearly separated from the soil within the foreland. Rotmoosferner bacterial communities were clearly distinct from the other two glacier forelands (Figure 2), even more so when only presence/absence of OTUs was used (Figure S1). Despite these clear changes in microbial community structure, neither Shannon diversity nor the Gini coefficient of taxonomic bacterial community composition changed with soil age, and OTU richness increased with soil age only in the Rotmoosferner glacier foreland (Figure S2). The relative abundance of several phyla changed significantly with soil age (Figure S3). In particular, the relative abundance of *Proteobacteria* and *Actinobacteria* decreased with soil age, while that of *Acidobacteria*, *Planctomycetes*, *Verrucomicrobia* and *Chloroflexi* increased.

3.3 | ^{15}N uptake, retention, and leaching

Roots and microbial biomass were the ecosystem N pools that took up and retained the largest amount of added ^{15}N ; across all soil ages and glaciers they retained on average 0.56 and 0.62 g $^{15}\text{N}/\text{m}^2$, respectively, or 28% and 31% of the ^{15}N added (Figure 3). These amounts varied strongly across soil age and glacier, though the apparent increase in ^{15}N uptake by roots with soil age was not significant ($p = 0.094$; Figure 3). Similarly, microbial ^{15}N uptake and shoot ^{15}N uptake were not affected by soil age, although the latter tended to decrease with soil age ($p = 0.079$; Figure 3). On average, 0.13 g, or 6%, of the added ^{15}N leached from the soil with the simulated rainfall event, but the amount of ^{15}N leached did not change with

ecosystem succession. As a result, ecosystem ^{15}N retention was not affected by soil age.

Despite the absence of an effect of soil age on ecosystem ^{15}N uptake and retention, a significant part of the variation in ^{15}N uptake in plant and microbial pools was explained by ecosystem properties that did change with succession. Microbial ^{15}N uptake increased with a larger microbial biomass N pool and with decreasing microbial C/N ratio (Table 2). In addition, microbial ^{15}N uptake decreased with greater soil nitrate concentrations, and was also linked to changes in bacterial community composition (PCoA axis 2 scores). The model for shoot ^{15}N uptake explained more variation than the model for microbial ^{15}N uptake (40% vs. 28%); shoot ^{15}N uptake increased with a larger shoot N pool and decreased with soil total N. The model for root ^{15}N uptake included more variables and explained the largest amount of variation (48%) of ^{15}N uptake in biotic ecosystem pools. Root ^{15}N uptake increased with higher root C/N ratio and root biomass, but the interaction between the two meant that high root C/N ratios increased root ^{15}N uptake at low root biomass and decreased root ^{15}N uptake at high root biomass (Figure S4). In addition, root ^{15}N uptake decreased with increasing soil ammonium concentrations. Total ecosystem ^{15}N retention increased with increasing microbial biomass N and was also explained by PCoA axis 2 scores of bacterial community composition; this model explained 24% of variation. Finally, 13% of the variation in ^{15}N leaching was explained by a combination of soil C/N ratio and bacterial community composition, where leaching increased in soils with increasing soil C/N ratio.

The volume leached from the intact soil cores increased slightly with higher soil moisture content and the amount of ^{15}N leached weakly increased with the volume leached ($p = 0.013$ and $R^2 = 0.068$ and $p = 0.063$ and $R^2 = 0.041$, respectively; Figure S5). However, the amount of ^{15}N leached decreased when soil moisture was higher ($p = 0.004$ and $R^2 = 0.095$, Figure S6). The total recovery of ^{15}N in plants, soil, and leachates together was variable and not affected by soil age and glacier, and, in general, did not amount to the full 2 g/m² of ^{15}N added (Figure S6). The average recovery of added ^{15}N was 78.4 ± 29.9 ($M \pm SD$) % across all soil ages and glaciers, and therefore, for ^{15}N tracer experiments, relatively complete.

3.4 | ^{15}N enrichment of ecosystem N pools

Similar to total ^{15}N uptake in ecosystem N pools, ^{15}N enrichment (i.e. the percentage of ^{15}N enrichment in each ecosystem N pool, which is independent of the size of the pool) of ecosystem N pools varied little with soil age. Neither microbial, root, nor shoot ^{15}N enrichment changed with successional stage (Figure S7). In contrast, soil ^{15}N enrichment decreased with soil age across the foreland of all three glaciers. Microbial ^{15}N enrichment increased with increasing PCoA axis 2 scores, i.e. microbial communities in the younger sites of Damma and Ödenwinkelkees were most enriched (Table S6). The model for ^{15}N enrichment of shoot N only explained 8.3% of the variation and showed that shoot ^{15}N enrichment increased with higher root C/N ratio. In contrast, 68% and 69% of variation in root and soil ^{15}N

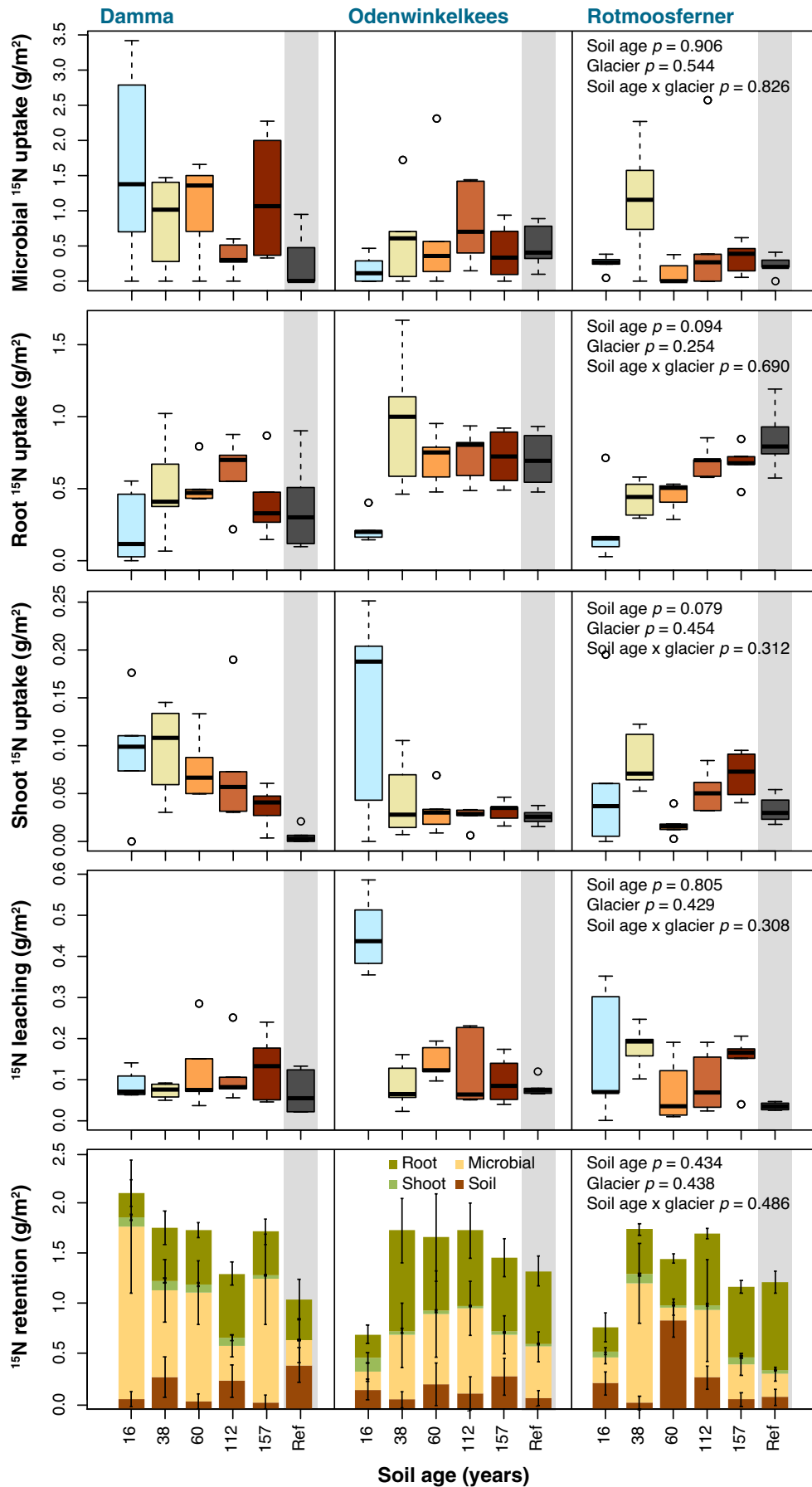

FIGURE 3 Uptake, leaching, and retention of ¹⁵N 48 hr after addition in different ecosystem N pools as affected by soil age and glacier

TABLE 2 Selected linear mixed effects models for ^{15}N uptake, retention, and leaching. All biomass, C, and N parameters are expressed in g/m^2

	In Microbial ^{15}N uptake (g/m^2)		In Shoot ^{15}N uptake (g/m^2)		Root ^{15}N uptake (g/m^2)		^{15}N retention (g/m^2)		In ^{15}N leaching (g/m^2)	
	Parameter value	<i>p</i>	Parameter value	<i>p</i>	Parameter value	<i>p</i>	Parameter value	<i>p</i>	Parameter value	<i>p</i>
Intercept	+0.142	0.138	+0.129	<0.0001	-0.053	<0.0001	+0.993	<0.0001	-4.007	<0.0001
Soil C and N pools			-0.028 × ln Soil N	<0.0001					+0.544 × ln Soil C/N	0.030
Microbial C and N pools	+0.053 × Micr N -0.068 × ln Micr C/N	<0.0001 0.0183					+0.080 × Micr N	<0.0001		
Plant C and N pools			+0.028 × ln Shoot N	0.006	+0.011 × Root C/N +0.0005 × Root biom -0.000007 × Root C/N × Root biom	<0.0001 <0.0001 0.0007				
Soil dissolved C and N pools	-0.118 × ln NO_3^-	0.0067			-0.282 × ln NH_4^+	0.0077				
Microbial community properties	+0.525 × PCoA2	0.086			+1.346 × PCoA2	0.009	+1.823 × PCoA2	0.013		
<i>df</i>	53		65		68		65		61	
AIC	47.2		-286.9		57.5		146.8		224.7	
R^2	0.366		0.401		0.481		0.238		0.129	

Abbreviations: Micr C/N, microbial biomass C/N ratio; Micr N, microbial biomass N; PCoA2, PCoAaxis 2 scores for bacterial community composition.

enrichment was explained by the selected models, respectively. ^{15}N enrichment of the root N pool decreased with a larger root N pool size and increasing root biomass. Similar to total root ^{15}N uptake, root ^{15}N enrichment also decreased when soil ammonium concentrations increased. Soil ^{15}N enrichment decreased with an increasing size of the soil N pool.

3.5 | Direct and indirect controls on plant and microbial ^{15}N uptake and ^{15}N leaching

Structural equation modelling (SEM) is a robust statistical method to test how well experimental data fit a hypothesised causal structure that is based on prior knowledge (Grace, 2006). To test our hypothesis that N-conservative plants (with high tissue C/N ratio) select for N-conservative microbial communities (with high microbial biomass C/N ratio), which would in turn increase microbial immobilisation, we fitted our data to a previously hypothesised and tested SEM (De Vries & Bardgett, 2016). Importantly, in a previous common garden experiment, this SEM showed that low microbial biomass C/N ratios increased microbial N immobilisation, which contrasts with our current hypothesis (De Vries & Bardgett, 2016). The data fitted this model well and confirmed that plant C/N ratio and root biomass determine plant and microbial ^{15}N uptake and leaching (Figure 4). Shoot C/N ratio, root C/N ratio, and root biomass were all correlated. Roots with a high tissue C/N ratio were linked to microbial communities with a high C/N ratio, which, in contrast to our hypothesis, in turn immobilised *less* ^{15}N . In addition, high root biomass increased plant ^{15}N uptake, which decreased ^{15}N leaching. ^{15}N leaching was only controlled by plant ^{15}N uptake, not by microbial ^{15}N immobilisation.

4 | DISCUSSION

Using the forelands of three geographically distinct retreating glaciers in the European Alps as a model system, we were able to

disentangle the plant and microbial properties that regulate ecosystem uptake and short-term retention of N during ecosystem succession. Many ecosystem properties changed in a predictable way during succession across the three glaciers but, in contrast to our hypothesis, neither microbial or plant ^{15}N uptake, nor ecosystem retention of added ^{15}N increased as succession proceeds. However, total ecosystem ^{15}N retention and microbial ^{15}N uptake, the second largest sink for added ^{15}N , increased with a greater microbial biomass N pool, which itself increased with soil age across all three glacier forelands. Plant ^{15}N uptake, rather than microbial ^{15}N uptake, decreased the amount of ^{15}N lost via leaching and, in contrast to our expectation, ^{15}N leaching increased with higher soil C/N ratios. Moreover, we found that microbial ^{15}N uptake, a measure of microbial immobilisation of N, was primarily determined by the C/N stoichiometry and biomass of soil microbial communities, with a minor role for changes in the composition of bacterial communities.

Soil microbial communities were strongly affected by soil age. Microbial biomass, DNA concentration, AOA abundance, and fungal and bacterial biomass (assessed by qPCR) all increased with time since deglaciation, as well as abundances of several bacterial phyla previously reported to increase with succession (Nemergut et al., 2007). The AOA:AOB gene abundance ratio increased with soil age, which was previously reported also in a salt marsh successional gradient (Salles et al., 2017), possibly as a consequence of a preference of AOA for acidic soils (Nicol et al., 2008). However, in contrast to our expectation, the ratio of fungi-to-bacteria, which has been shown to increase during ecosystem succession (Bardgett et al., 2007; Ohtonen et al., 1999), and has been linked to increased microbial N immobilisation (De Vries, Bloem, et al., 2012), did not increase. Bacterial community composition was affected by soil age across the three glacier forelands, although this pattern differed between the glaciers, with communities within the Rotmoosferner foreland being more similar across soil ages than those in Damma and Ödenwinkelkees forelands. Bacterial communities in the Rotmoosferner foreland were also distinctly different from those of the other two forelands. Soil pH and C are known to be important

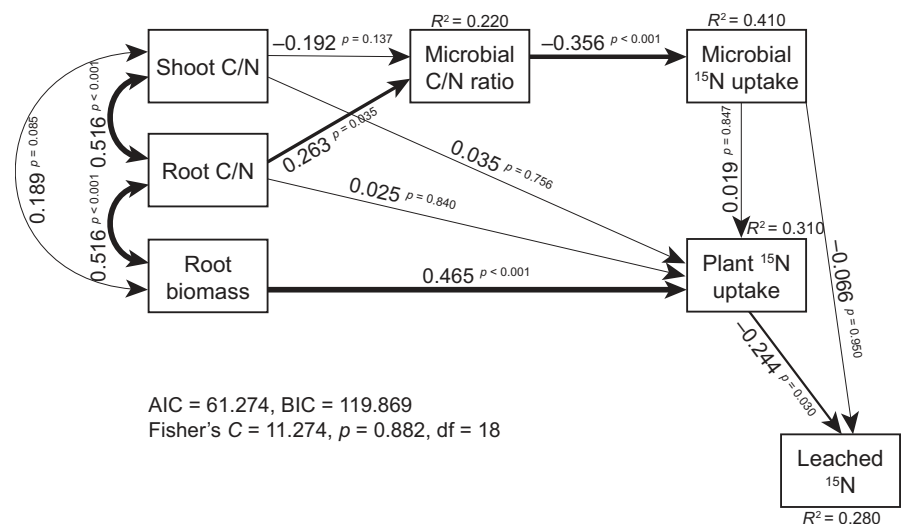

FIGURE 4 Structural equation model explaining plant and microbial ^{15}N uptake and ^{15}N leaching across all glaciers and soil ages

drivers of bacterial community composition (Delgado-Baquerizo et al., 2016; Lauber et al., 2009) and thus these patterns are likely caused by the high pH at Rotmoosferner, as well as by a weaker effect of soil age on pH and soil C than at the other two glacier forelands. PCoA axis 2 scores of bacterial community composition, which separated the Rotmoosferner from the Damma and Ödenwinkelkees forelands, were the only DNA-based microbial community properties included in our models for explaining ^{15}N pools and enrichment. Specifically, microbial ^{15}N uptake and enrichment, ^{15}N leaching and ^{15}N retention all increased with increasing PCoA axis 2 scores, i.e. with bacterial communities of the younger sites of Damma and Ödenwinkelkees. However, PCoA axis 2 only explained 9% of the variation in bacterial community composition.

Rather than microbial community composition, whole-community stoichiometry explained microbial uptake and enrichment of ^{15}N , irrespective of glacier foreland and soil age. Microbial ^{15}N uptake increased with a greater microbial biomass N pool and with lower microbial biomass C/N ratio, indicating that microbial communities with high N demand immobilised most added ^{15}N . This finding is consistent with observations in controlled experiments (De Vries & Bardgett, 2016; Myrold & Posavatz, 2007), but contradicts field observations that fungal-dominated microbial communities of high C/N ratio immobilise more added N than bacterial-dominated microbial communities of low C/N ratio (De Vries, Bloem, et al., 2012; De Vries et al., 2011). And while soil C stocks or C/N ratios did not explain microbial ^{15}N uptake, microbial ^{15}N uptake decreased with increasing soil nitrate concentrations, indicating that N limitation did drive microbial ^{15}N uptake (Table 2). A similar pattern was found for root and shoot ^{15}N uptake. Shoot ^{15}N uptake increased with a larger shoot N pool, and root ^{15}N uptake was highest with high root biomass and decreased with higher soil ammonium concentrations, again indicating that ^{15}N uptake was driven both by N demand and N limitation. This was confirmed by our structural equation model, which showed that across these distinctly different glacier forelands, ecosystem N uptake was determined by plant and microbial N demand. Thus, our results indicate that previously observed high microbial N immobilisation by fungal-dominated microbial communities of high C/N ratio (De Vries, Bloem, et al., 2012; De Vries et al., 2011) is a result of ecosystem N limitation, rather than of an innate high affinity of fungi for N.

Despite the finding that both plant and microbial ^{15}N uptake were driven by their N demand, we found no evidence for competition between plants and microbes for ^{15}N , as indicated by the lack of a significant negative effect of microbial ^{15}N uptake on plant ^{15}N uptake (Figure 4). Microbes have been shown to be stronger competitors for N than plant roots in N-limited systems on short time scales (Bardgett et al., 2003; Harrison et al., 2007), and it has been suggested that through selecting for specific soil microbial communities, plants can alter the microbial sink strength for N (De Vries et al., 2015). We did indeed find that high root C/N ratios, indicative of conservative plant nutrient acquisition strategies (Figure S4), were associated with microbial communities with a high biomass C/N ratio that, however, took up less ^{15}N . Still, high root C/N ratios

were only linked to reduced root N uptake when root biomass was high, which suggests that when both root and microbial C/N ratios were low, plants might have increased their N uptake through investing more in root biomass. In N-limited ecosystems like the alpine glacier forelands studied here, the preferential uptake of different forms of N can alleviate N competition between plants and microbes. This chemical niche partitioning has primarily been found between inorganic and organic N forms, but also between various forms of organic N (amino acids; Bardgett et al., 2003; Harrison et al., 2007; Raab et al., 1999). Our results point to a partitioning of the uptake of inorganic N forms: high soil concentrations of nitrate were associated with lower microbial ^{15}N uptake, while high soil ammonium concentrations were associated with lower root ^{15}N uptake, respectively. This finding suggests that microbes were limited by nitrate and plants by ammonium, thus when more of these forms were present the added ^{15}N -forms were diluted more, and microbial and root uptake of added ^{15}N was reduced through a saturation effect (Grassein et al., 2015). This is consistent with the knowledge that subalpine grassland plants, especially more conservative species, have higher ammonium than nitrate uptake rates (Legay et al., 2020), and suggests coordination between plant and microbial N uptake strategies beyond broad-scale tissue N requirements, as has been found before (Moreau et al., 2015; Theodose et al., 1996).

As expected, roots and microbes together accounted for the largest proportion of ^{15}N retention. After rapid initial uptake by microbes, N is gradually released through microbial turnover and either lost from the system (Ma et al., 2020), or taken up by roots. Root N is subsequently translocated to aboveground biomass (De Vries, Bloem, et al., 2012; Harrison et al., 2007), and eventually transferred to soil organic matter pools via shoot, root, and microbial turnover (Zogg et al., 2000). However, N turnover and uptake dynamics in mountain ecosystems vary strongly over the growing season (Broadbent et al., 2021), with plant and microbial uptake and competition increasing towards peak biomass (Bardgett et al., 2002). Thus, our findings from the late growing season may not reflect ecosystem N uptake and retention in the early growing season. The average total amount of ^{15}N retained in our systems was relatively high (73%) compared to N retention in temperate grasslands (De Vries, Bloem, et al., 2012; Templer et al., 2012; Wang et al., 2018), and comparable to shrubland N retention (Templer et al., 2012). However, it is important to note that we only collected intact soil cores that included plants, whereas plant cover was sparse during early successional stages. As a result, our method will have resulted in an overestimation of ecosystem N retention per square meter in the field, especially for the most recently deglaciated soils. Because of the large contribution of plant and microbial ^{15}N uptake to ecosystem N retention, it is therefore plausible that whole-ecosystem N retention increases with succession.

Our study identifies fundamental plant and microbial controls on short-term ecosystem N retention, and establishes that plant and microbial N demand, as well as N limitation, are driving short-term ecosystem N retention in glacier forelands. Importantly, these findings are in line with experimental studies in grasslands and forests,

as well as with recent adaptations to Vitousek and Reiners conceptual model of nutrient retention (Lajtha, 2019; Lovett et al., 2018; Vitousek & Reiners, 1975). We did not find an increase in N retention with succession, despite multiple studies finding that glacier forelands shift from being P-limited to being N-limited during early stages of succession (Darcy et al., 2018; Göransson et al., 2016), likely because the main determinants of plant and microbial ^{15}N uptake were not affected by soil age. Our findings highlight the importance of plant and microbial interactions as fundamental controls on ecosystem N retention, which has implications for predicting the effects of increasing atmospheric deposition of reactive N on terrestrial ecosystems and understanding the mechanisms that underpin the retention of this N.

ACKNOWLEDGEMENTS

This work was funded by a British Ecological Society Early Career Project Grant to Franciska de Vries. Stable isotope analyses were funded by a NERC Life Sciences Mass Spectrometry Steering Committee Grant to Franciska de Vries. Franciska de Vries was supported by a BBSRC David Phillips Fellowship (BB/L02456X/1) and Cécile Thion was funded by NERC NE/L006286/1 and the AXA Research Fund. Benoît Bergk Pinto was funded by the EU Horizon 2020 research and innovation program under the Marie Skłodowska-Curie ITN 675546—MicroArctic. We thank Victor van Velzen and Caley Brown for help in the laboratory, and Matthew Gemmel and Elaina Collie-Duguid, the Centre for Genome Enabled Biology and Medicine, University of Aberdeen, UK, for advice and bioinformatics support.

CONFLICTS OF INTEREST

F.T.d.V. is an Associate Editor of Journal of Ecology, but took no part in the peer review and decision making process for this paper. R.D.B. is a Senior Editor of Journal of Ecology, but took no part in the peer review and decision making process for this paper. The other authors have no conflicts of interest.

AUTHORS' CONTRIBUTIONS

F.T.d.V., R.D.B., C.T. and J.I.P. conceived the study; F.T.d.V., R.D.B., W.W., B.F., M.B. planned and performed field work; F.T.d.V., C.T. and H.G. performed laboratory analyses; F.T.d.V., C.T., B.B.P., S.C., G.W.N., analysed data and F.T.d.V., C.T., J.I.P. and R.D.B. wrote the manuscript with significant inputs from all authors.

PEER REVIEW

The peer review history for this article is available at <https://publons.com/publon/10.1111/1365-2745.13748>.

DATA AVAILABILITY STATEMENT

Data and code are available from <https://doi.org/10.6084/m9.figshare.13913024.v3> (De Vries, 2021). This Targeted Locus Study project has been deposited at DDBJ/ENA/GenBank under the accession KCJZ00000000. The version described in this paper is the first version, KCJZ01000000.

ORCID

Franciska T. de Vries  <https://orcid.org/0000-0002-6822-8883>
Richard D. Bardgett  <https://orcid.org/0000-0002-5131-0127>

REFERENCES

- Bardgett, R. D., Richter, A., Bol, R., Garnett, M. H., Bäumler, R., Xu, X., Lopez-Capel, E., Manning, D. A. C., Hobbs, P. J., Hartley, I. R., & Wanek, W. (2007). Heterotrophic microbial communities use ancient carbon following glacial retreat. *Biology Letters*, 3, 487–490. <https://doi.org/10.1098/rsbl.2007.0242>
- Bardgett, R. D., Streeter, T. C., & Bol, R. (2003). Soil microbes compete effectively with plants for organic-nitrogen inputs to temperate grasslands. *Ecology*, 84, 1277–1287. [https://doi.org/10.1890/0012-9658\(2003\)084%5B1277:SMCEWP%5D2.0.CO;2](https://doi.org/10.1890/0012-9658(2003)084%5B1277:SMCEWP%5D2.0.CO;2)
- Bardgett, R. D., Streeter, T. C., Cole, L., & Hartley, I. R. (2002). Linkages between soil biota, nitrogen availability, and plant nitrogen uptake in a mountain ecosystem in the Scottish Highlands. *Applied Soil Ecology*, 19, 121–134. [https://doi.org/10.1016/S0929-1393\(01\)00188-3](https://doi.org/10.1016/S0929-1393(01)00188-3)
- Bernasconi, S. M., Bauder, A., Bourdon, B., Brunner, I., Bunemann, E., Christl, I., Derungs, N., Edwards, P., Farinotti, D., Frey, B., Frossard, E., Furrer, G., Gierga, M., Goransson, H., Gulland, K., Hagedorn, F., Hajdas, I., Hindshaw, R., Ivy-Ochs, S., ... Zumsteg, A. (2011). Chemical and biological gradients along the damma glacier soil chronosequence, Switzerland. *Vadose Zone Journal*, 10, 867–883. <https://doi.org/10.2136/vzj2010.0129>
- Bradley, J. A., Singarayer, J. S., & Anesio, A. M. (2014). Microbial community dynamics in the forefield of glaciers. *Proceedings of the Royal Society B: Biological Sciences*, 281, 9. <https://doi.org/10.1098/rspb.2014.0882>
- Brandt, B. W., Bonder, M. J., Huse, S. M., & Zaura, E. (2012). TaxMan: A server to trim rRNA reference databases and inspect taxonomic coverage. *Nucleic Acids Research*, 40, W82–W87. <https://doi.org/10.1093/nar/gks418>
- Brankatschk, R., Towe, S., Kleinedam, K., Schloter, M., & Zeyer, J. (2011). Abundances and potential activities of nitrogen cycling microbial communities along a chronosequence of a glacier forefield. *ISME Journal*, 5, 1025–1037. <https://doi.org/10.1038/ismej.2010.184>
- Broadbent, A. A. D., Snell, H. S. K., Michas, A., Pritchard, W. J., Newbold, L., Cordero, I., Goodall, T., Schallhart, N., Kaufmann, R., Griffiths, R. I., Schloter, M., Bahn, M., & Bardgett, R. D. (2021). Climate change alters temporal dynamics of alpine soil microbial functioning and biogeochemical cycling via earlier snowmelt. *The ISME Journal*. <https://doi.org/10.1038/s41396-021-00922-0>
- Brookes, P. C., Landman, A., Pruden, G., & Jenkinson, D. S. (1985). Chloroform fumigation and the release of soil-nitrogen – A rapid direct extraction method to measure microbial biomass nitrogen in soil. *Soil Biology & Biochemistry*, 17, 837–842. [https://doi.org/10.1016/0038-0717\(85\)90144-0](https://doi.org/10.1016/0038-0717(85)90144-0)
- Castle, S. C., Sullivan, B. W., Knelman, J., Hood, E., Nemergut, D. R., Schmidt, S. K., & Cleveland, C. C. (2017). Nutrient limitation of soil microbial activity during the earliest stages of ecosystem development. *Oecologia*, 185, 513–524. <https://doi.org/10.1007/s00442-017-3965-6>
- Chapin, F. S., Walker, L. R., Fastie, C. L., & Sharman, L. C. (1994). Mechanisms of primary succession following deglaciation at Glacier Bay, Alaska. *Ecological Monographs*, 64, 149–175. <https://doi.org/10.2307/2937039>
- Crocker, R. L., & Major, J. (1955). Soil development in relation to vegetation and surface age at Glacier Bay, Alaska. *Journal of Ecology*, 43, 427. <https://doi.org/10.2307/2257005>
- Darcy, J. L., Schmidt, S. K., Knelman, J. E., Cleveland, C. C., Castle, S. C., & Nemergut, D. R. (2018). Phosphorus, not nitrogen, limits plants and microbial primary producers following glacial retreat. *Science Advances*, 4, eaq0942. <https://doi.org/10.1126/sciadv.aq0942>

- De Vries, F. T., & Bardgett, R. D. (2016). Plant community controls on short-term ecosystem nitrogen retention. *New Phytologist*, 210, 861–874. <https://doi.org/10.1111/nph.13832>
- De Vries, F. T., Bloem, J., Quirk, H., Stevens, C. J., Bol, R., & Bardgett, R. D. (2012). Extensive management promotes plant and microbial nitrogen retention in temperate grassland. *PLoS ONE*, 7, e51201. <https://doi.org/10.1371/journal.pone.0051201>
- De Vries, F. T., Bracht Jørgensen, H., Hedlund, K., & Bardgett, R. D. (2015). Disentangling plant and soil microbial controls on carbon and nitrogen loss in grassland mesocosms. *Journal of Ecology*, 103, 629–640. <https://doi.org/10.1111/1365-2745.12383>
- De Vries, F. T., Hoffland, E., van Eekeren, N., Brussaard, L., & Bloem, J. (2006). Fungal/bacterial ratios in grasslands with contrasting nitrogen management. *Soil Biology & Biochemistry*, 38, 2092–2103. <https://doi.org/10.1016/j.soilbio.2006.01.008>
- De Vries, F. T., Manning, P., Tallowin, J. R. B., Mortimer, S. R., Pilgrim, E. S., Harrison, K. A., Hobbs, P. J., Quirk, H., Shipley, B., Cornelissen, J. H. C., Kattge, J., & Bardgett, R. D. (2012). Abiotic drivers and plant traits explain landscape-scale patterns in soil microbial communities. *Ecology Letters*, 15, 1230–1239. <https://doi.org/10.1111/j.1461-0248.2012.01844.x>
- De Vries, F. T., Thion, C., Bahn, M., Bergk Pinto, B., Cécillon, S., Frey, B., Grant, H., Nicol, G. W., Wanek, W., Prosser, J., & Bardgett, R. D. (2021). Data and R scripts for De Vries et al. 2021 [Dataset]. *figshare*, <https://doi.org/10.6084/m9.figshare.13913024.v3>
- De Vries, F. T., Van Groenigen, J. W., Hoffland, E., & Bloem, J. (2011). Nitrogen losses from two grassland soils with different fungal biomass. *Soil Biology & Biochemistry*, 43, 997–1005. <https://doi.org/10.1016/j.soilbio.2011.01.016>
- Delgado-Baquerizo, M., Maestre, F. T., Reich, P. B., Trivedi, P., Osanai, Y., Liu, Y. R., Hamonts, K., Jeffries, T. C., & Singh, B. K. (2016). Carbon content and climate variability drive global soil bacterial diversity patterns. *Ecological Monographs*, 86, 373–390. <https://doi.org/10.1002/ecm.1216>
- Edgar, R. C. (2010). Search and clustering orders of magnitude faster than BLAST. *Bioinformatics*, 26, 2460–2461. <https://doi.org/10.1093/bioinformatics/btq461>
- Felske, A., Akkermans, A. D. L., & De Vos, W. M. (1998). Quantification of 16S rRNAs in complex bacterial communities by multiple competitive reverse transcription PCR in temperature gradient gel electrophoresis fingerprints. *Applied and Environmental Microbiology*, 64, 4581–4587. <https://doi.org/10.1128/AEM.64.11.4581-4587.1998>
- Göransson, H., Venterink, H. O., & Baath, E. (2011). Soil bacterial growth and nutrient limitation along a chronosequence from a glacier forefield. *Soil Biology & Biochemistry*, 43, 1333–1340. <https://doi.org/10.1016/j.soilbio.2011.03.006>
- Göransson, H., Welc, M., Bunemann, E. K., Christl, I., & Venterink, H. O. (2016). Nitrogen and phosphorus availability at early stages of soil development in the Damma glacier forefield, Switzerland; implications for establishment of N₂-fixing plants. *Plant and Soil*, 404, 251–261. <https://doi.org/10.1007/s11104-016-2821-5>
- Grace, J. B. (2006). *Structural equation modeling and natural systems*. Cambridge University Press.
- Grassein, F., Lemauviel-Lavenant, S., Lavorel, S., Bahn, M., Bardgett, R. D., Desclos-Theveniau, M., & Laine, P. (2015). Relationships between functional traits and inorganic nitrogen acquisition among eight contrasting European grass species. *Annals of Botany*, 115, 107–115. <https://doi.org/10.1093/aob/mcu233>
- Griffiths, R. I., Whiteley, A. S., O'Donnell, A. G., & Bailey, M. J. (2000). Rapid method for coextraction of DNA and RNA from natural environments for analysis of ribosomal DNA- and rRNA-based microbial community composition. *Applied and Environmental Microbiology*, 66, 5488–5491. <https://doi.org/10.1128/AEM.66.12.5488-5491.2000>
- Grigulis, K., Lavorel, S., Krainer, U., Legay, N., Baxendale, C., Dumont, M., Kastl, E., Arnoldi, C., Bardgett, R. D., Poly, F., Pommier, T., Schloter, M., Tappeiner, U., Bahn, M., & Clément, J.-C. (2013). Relative contributions of plant traits and soil microbial properties to mountain grassland ecosystem services. *Journal of Ecology*, 101, 47–57. <https://doi.org/10.1111/1365-2745.12014>
- Harrison, K. A., Bol, R., & Bardgett, R. D. (2007). Preferences for different nitrogen forms by coexisting plant species and soil microbes. *Ecology*, 88, 989–999. <https://doi.org/10.1890/06-1018>
- Kandeler, E., Deiglmayr, K., Tschirko, D., Bru, D., & Philippot, L. (2006). Abundance of narG, nirS, nirK, and nosZ genes of denitrifying bacteria during primary successions of a glacier foreland. *Applied and Environmental Microbiology*, 72, 5957–5962.
- Kaufmann, R. (2001). Invertebrate succession on an alpine glacier foreland. *Ecology*, 82, 2261–2278. [https://doi.org/10.1890/0012-9658\(2001\)082%5B2261:ISOAAG%5D2.0.CO;2](https://doi.org/10.1890/0012-9658(2001)082%5B2261:ISOAAG%5D2.0.CO;2)
- Klindworth, A., Pruesse, E., Schweer, T., Peplies, J., Quast, C., Horn, M., & Glöckner, F. O. (2013). Evaluation of general 16S ribosomal RNA gene PCR primers for classical and next-generation sequencing-based diversity studies. *Nucleic Acids Research*, 41, e1. <https://doi.org/10.1093/nar/gks808>
- Lajtha, K. (2019). Nutrient retention and loss during ecosystem succession: Revisiting a classic model. *Ecology*, 101, e02896.
- Lauber, C. L., Hamady, M., Knight, R., & Fierer, N. (2009). Pyrosequencing-based assessment of soil pH as a predictor of soil bacterial community structure at the continental scale. *Applied and Environmental Microbiology*, 75, 5111–5120. <https://doi.org/10.1128/AEM.00335-09>
- Lefcheck, J. S. (2016). PIECEWISESEM: Piecewise structural equation modelling in R for ecology, evolution, and systematics. *Methods in Ecology and Evolution*, 7, 573–579.
- Legay, N., Grassein, F., Arnoldi, C., Segura, R., Laine, P., Lavorel, S., & Clement, J. C. (2020). Studies of NH₄⁺ and NO₃⁻ uptake ability of subalpine plants and resource-use strategy identified by their functional traits. *Oikos*, 129, 830–841.
- Lovett, G. M., Goodale, C. L., Ollinger, S. V., Fuss, C. B., Ouimette, A. P., & Likens, G. E. (2018). Nutrient retention during ecosystem succession: A revised conceptual model. *Frontiers in Ecology and the Environment*, 16, 532–538. <https://doi.org/10.1002/fee.1949>
- Lueders, T., Wagner, B., Claus, P., & Friedrich, M. W. (2004). Stable isotope probing of rRNA and DNA reveals a dynamic methylotroph community and trophic interactions with fungi and protozoa in oxalic rice field soil. *Environmental Microbiology*, 6, 60–72. <https://doi.org/10.1046/j.1462-2920.2003.00535.x>
- Ma, L. N., Gao, X. L., Liu, G. F., Xu, X. F., Lu, X. T., Xin, X. P., Lu, Y. X., Zhang, C. X., Zhang, L. H., & Wang, R. Z. (2020). The retention dynamics of N input within the soil-microbe-plant system in a temperate grassland. *Geoderma*, 368, 114290. <https://doi.org/10.1016/j.geoderma.2020.114290>
- Manning, P., de Vries, F. T., Tallowin, J. R. B., Smith, R., Mortimer, S. R., Pilgrim, E. S., Harrison, K. A., Wright, D. G., Quirk, H., Benson, J., Shipley, B., Cornelissen, J. H. C., Kattge, J., Bönisch, G., Wirth, C., & Bardgett, R. D. (2015). Simple measures of climate, soil properties and plant traits predict national-scale grassland soil carbon stocks. *Journal of Applied Ecology*, 52, 1188–1196. <https://doi.org/10.1111/1365-2664.12478>
- Masella, A. P., Bartram, A. K., Truszkowski, J. M., Brown, D. G., & Neufeld, J. D. (2012). PANDAseq: PAired-eND assembler for illumina sequences. *BMC Bioinformatics*, 13, 7. <https://doi.org/10.1186/1471-2105-13-31>
- Moreau, D., Pivato, B., Bru, D., Busset, H., Deau, F., Faivre, C., Matejicek, A., Strbik, F., Philippot, L., & Mougél, C. (2015). Plant traits related to nitrogen uptake influence plant-microbe competition. *Ecology*, 96, 2300–2310. <https://doi.org/10.1890/14-1761.1>
- Myrold, D. D., & Posavatz, N. R. (2007). Potential importance of bacteria and fungi in nitrate assimilation in soil. *Soil Biology & Biochemistry*, 39, 1737–1743. <https://doi.org/10.1016/j.soilbio.2007.01.033>

- Nemergut, D. R., Anderson, S. P., Cleveland, C. C., Martin, A. P., Miller, A. E., Seimon, A., & Schmidt, S. K. (2007). Microbial community succession in an unvegetated, recently deglaciated soil. *Microbial Ecology*, *53*, 110–122. <https://doi.org/10.1007/s00248-006-9144-7>
- Nicol, G. W., Leininger, S., Schleper, C., & Prosser, J. I. (2008). The influence of soil pH on the diversity, abundance and transcriptional activity of ammonia oxidizing archaea and bacteria. *Environmental Microbiology*, *10*, 2966–2978. <https://doi.org/10.1111/j.1462-2920.2008.01701.x>
- Nicol, G. W., Tscherko, D., Embley, T. M., & Prosser, J. I. (2005). Primary succession of soil Crenarchaeota across a receding glacier foreland. *Environmental Microbiology*, *7*, 337–347. <https://doi.org/10.1111/j.1462-2920.2005.00698.x>
- Northup, R. R., Yu, Z. S., Dahlgren, R. A., & Vogt, K. A. (1995). Polyphenol control of nitrogen release from pine litter. *Nature*, *377*, 227–229. <https://doi.org/10.1038/377227a0>
- Ohtonen, R., Fritze, H., Pennanen, T., Jumpponen, A., & Trappe, J. (1999). Ecosystem properties and microbial community changes in primary succession on a glacier forefront. *Oecologia*, *119*, 239–246. <https://doi.org/10.1007/s004420050782>
- Oksanen, J., Blanchet, F., Kindt, R., Legendre, P., Minchin, P., O'Hara, R., Simpson, G., Solymos, P., Stevens, M., Szoaecs, E., & Wagner, H. (2017). *vegan: Community ecology package*. R package version 2.4-4. Retrieved from <https://CRAN.R-project.org/package=vegan>
- Philippot, L., Tscherko, D., Bru, D., & Kandeler, E. (2011). Distribution of high bacterial taxa across the chronosequence of two alpine glacier forelands. *Microbial Ecology*, *61*, 303–312. <https://doi.org/10.1007/s00248-010-9754-y>
- Pinheiro, J., Bates, D., DebRoy, S., Sarkar, D., & R Core Team. (2020). *nlme: Linear and nonlinear mixed effects models*. R package version 3.1-149.
- R Core Team. (2018). *R: A language and environment for statistical computing*. R Foundation for Statistical Computing.
- Raab, T. K., Lipson, D. A., & Monson, R. K. (1999). Soil amino acid utilization among species of the Cyperaceae: Plant and soil processes. *Ecology*, *80*, 2408–2419. [https://doi.org/10.1890/0012-9658\(1999\)080%5B2408:SAUAS%5D2.0.CO;2](https://doi.org/10.1890/0012-9658(1999)080%5B2408:SAUAS%5D2.0.CO;2)
- Rotthauwe, J. H., Witzel, K. P., & Liesack, W. (1997). The ammonia monooxygenase structural gene amoA as a functional marker: Molecular fine-scale analysis of natural ammonia-oxidizing populations. *Applied and Environmental Microbiology*, *63*, 4704–4712. <https://doi.org/10.1128/aem.63.12.4704-4712.1997>
- Salles, J. F., Silva, M., Dini-Andreote, F., Dias, A. C. F., Guillaumaud, N., Poly, F., & van Elsas, J. D. (2017). Successional patterns of key genes and processes involved in the microbial nitrogen cycle in a salt marsh chronosequence. *Biogeochemistry*, *132*, 185–201. <https://doi.org/10.1007/s10533-017-0296-y>
- Schlesinger, W. H. (2009). On the fate of anthropogenic nitrogen. *Proceedings of the National Academy of Sciences of the United States of America*, *106*, 203–208. <https://doi.org/10.1073/pnas.0810193105>
- Templer, P. H., Mack, M. C., Chapin, F. S., Christenson, L. M., Compton, J. E., Crook, H. D., Currie, W. S., Curtis, C. J., Dail, D. B., D'Antonio, C. M., Emmett, B. A., Epstein, H. E., Goodale, C. L., Gundersen, P., Hobbie, S. E., Holland, K., Hooper, D. U., Hungate, B. A., Lamontagne, S., ... Zak, D. R. (2012). Sinks for nitrogen inputs in terrestrial ecosystems: A meta-analysis of N-15 tracer field studies. *Ecology*, *93*, 1816–1829.
- Theodose, T. A., Jaeger, C. H., Bowman, W. D., & Schardt, J. C. (1996). Uptake and allocation of N-15 in alpine plants: Implications for the importance of competitive ability in predicting community structure in a stressful environment. *Oikos*, *75*, 59–66.
- Tourna, M., Freitag, T. E., Nicol, G. W., & Prosser, J. I. (2008). Growth, activity and temperature responses of ammonia-oxidizing archaea and bacteria in soil microcosms. *Environmental Microbiology*, *10*, 1357–1364. <https://doi.org/10.1111/j.1462-2920.2007.01563.x>
- Tscherko, D., Rustemeier, J., Richter, A., Wanek, W., & Kandeler, E. (2003). Functional diversity of the soil microflora in primary succession across two glacier forelands in the Central Alps. *European Journal of Soil Science*, *54*, 685–696. <https://doi.org/10.1046/j.1351-0754.2003.0570.x>
- Vitousek, P. M., & Matson, P. A. (1985). Disturbance, nitrogen availability, and nitrogen losses in an intensively managed loblolly-pine plantation. *Ecology*, *66*, 1360–1376. <https://doi.org/10.2307/1939189>
- Vitousek, P. M., & Reiners, W. A. (1975). Ecosystem succession and nutrient retention – Hypothesis. *BioScience*, *25*, 376–381.
- Walker, L. R., Wardle, D. A., Bardgett, R. D., & Clarkson, B. D. (2010). The use of chronosequences in studies of ecological succession and soil development. *Journal of Ecology*, *98*, 725–736. <https://doi.org/10.1111/j.1365-2745.2010.01664.x>
- Wang, F. P., Shi, G. X., Nicholas, O., Yao, B. Q., Ji, M. F., Wang, W. Y., Ma, Z., Zhou, H. K., & Zhao, X. Q. (2018). Ecosystem nitrogen retention is regulated by plant community trait interactions with nutrient status in an alpine meadow. *Journal of Ecology*, *106*, 1570–1581. <https://doi.org/10.1111/1365-2745.12924>
- Wang, R. Z., Bicharanloo, B., Shirvan, M. B., Cavagnaro, T. R., Jiang, Y., Keitel, C., & Dijkstra, F. A. (2021). A novel C-13 pulse-labelling method to quantify the contribution of rhizodeposits to soil respiration in a grassland exposed to drought and nitrogen addition. *New Phytologist*, *230*, 857–866.
- Wurzburger, N., & Hendrick, R. L. (2009). Plant litter chemistry and mycorrhizal roots promote a nitrogen feedback in a temperate forest. *Journal of Ecology*, *97*, 528–536. <https://doi.org/10.1111/j.1365-2745.2009.01487.x>
- Yoshitake, S., Uchida, M., Koizumi, H., & Nakatsubo, T. (2007). Carbon and nitrogen limitation of soil microbial respiration in a High Arctic successional glacier foreland near Ny-angstrom lesund, Svalbard. *Polar Research*, *26*, 22–30.
- Zeileis, A. (2014). *Measuring inequality, concentration, and poverty*. R package version 0.2-13. Retrieved from <https://CRAN.R-project.org/package=ineq>
- Zeng, J., Lou, K., Zhang, C. J., Wang, J. T., Hu, H. W., Shen, J. P., Zhang, L. M., Han, L. L., Zhang, T., Lin, Q., Chalk, P. M., & He, J. Z. (2016). Primary succession of nitrogen cycling microbial communities along the deglaciated forelands of Tianshan Mountain. *China Frontiers in Microbiology*, *7*, 12. <https://doi.org/10.3389/fmicb.2016.01353>
- Zogg, G. P., Zak, D. R., Pregitzer, K. S., & Burton, A. J. (2000). Microbial immobilization and the retention of anthropogenic nitrate in a northern hardwood forest. *Ecology*, *81*, 1858–1866. [https://doi.org/10.1890/0012-9658\(2000\)081%5B1858:MIATR0%5D2.0.CO;2](https://doi.org/10.1890/0012-9658(2000)081%5B1858:MIATR0%5D2.0.CO;2)

SUPPORTING INFORMATION

Additional supporting information may be found online in the Supporting Information section.

How to cite this article: de Vries, F. T., Thion, C., Bahn, M., Bergk Pinto, B., Cécillon, S., Frey, B., Grant, H., Nicol, G. W., Wanek, W., Prosser, J. I., & Bardgett, R. D. (2021). Glacier forelands reveal fundamental plant and microbial controls on short-term ecosystem nitrogen retention. *Journal of Ecology*, *109*, 3710–3723. <https://doi.org/10.1111/1365-2745.13748>