

Glucose Oxidase as an Analytical Reagent

Julio Raba and Horacio A. Mottola*

Department of Chemistry, Oklahoma State University, Stillwater, OK 74078–0447

“There is no doubt that methods based on catalysis by enzymes will increase in number and practicability as advances are made in the study of these substances and as more enzymes of known activity and purity become commercially available”

T.S. Lee, in *Organic Analysis*, Vol. 2; J. Mitchell, Jr., I.M. Kolthoff, E.S. Proskauer, A. Weissberger, Eds.; Interscience: New York, 1954, p. 242.

* Author to whom correspondence should be addressed.

Julio Raba's permanent address is: Departamento de Química Analítica, Facultad de Química, Bioquímica y Farmacia, Universidad Nacional de San Luis, 5700-San Luis, Argentina.

ABSTRACT: Glucose oxidase (EC 1.1.3.4) is the most widely employed enzyme as analytical reagent. This is the result of (1) its utility in the determination of glucose, an analyte of wide analytical interest, and (2) its relatively low cost and good stability that make the glucose/glucose oxidase system a very convenient model for method development (particularly in the area of biosensors). This review discusses in detail enzyme structure, biocatalysis, enzymes as analytical reagents, properties of glucose oxidase (including a historical account), and the use of glucose oxidase as an analytical reagent in homogeneous systems as well as an immobilized reagent.

KEY WORDS: enzymes as analytical reagents, glucose oxidase

Lee's forecast, quoted above, has been proved true. The real impact of enzymes as analytical reagents, however, was not felt until the mid-1960s and early 1970s, despite the fact that in 1951 Stetter¹ described applications of impure enzymes to a variety of analytical problems. Even as early as 1845, Osann² determined hydrogen peroxide using peroxidase. The use of enzyme preparations as analytical reagents, both soluble or immobilized on inert carriers, has grown exponentially since the 1970s.³ The enzyme glucose oxidase (EC 1.1.3.4) is, without doubt, the one employed most widely. Its use is so frequently mentioned

in the analytical literature that glucose oxidase is sometimes suspected to be abused rather than used. Such popularity is, however, the result of a combination of factors. Glucose oxidase is a useful reagent for the selective determination of glucose, an analyte of clinical as well as of industrial interest. Moreover, it is used as an analytical reagent as a marker of antigens and antibodies in enzyme immunoassays. It is used in the food industry to remove small amounts of oxygen from food products or glucose from diabetic drinks.⁴ In addition, glucose oxidase has been proposed as an anticancer drug^{5a,5b} because it may damage

cancerous tissue and cells as a result of hydrogen peroxide formation.

Glucose oxidase is commercially available with high purity and at relatively low cost. Also, its immobilization is rather easily achieved and results in preparations of adequate stability. Even in solution, its stability is competitive in view of its cost.⁶ In any event, the vast number of applications has not found an integrating forum. Consequently, this review is an attempt to critically describe the analytical uses of soluble and immobilized glucose oxidase. No attempt is made to cite all published work concerning its use as an analytical reagent, but only those reports in the authors' perception that have resulted in advances of the topic area. In many instances publications offer minor contributions to the advancement of the use of glucose oxidase (e.g., use of a different chromophore in an indicator reaction without substantial impact on the value of the method, minor variations in the chemistry of immobilization, or slightly different strategic approaches to the utilization of redox mediators in electrochemical sensing).

I. ENZYME STRUCTURE, BIOCATALYSIS, AND ENZYMES AS ANALYTICAL REAGENTS

Catalysis involves catalytic species that range from the simple proton to very complex molecular species in their architectural atomic arrangement such as enzymes. Because enzymes are biocatalysts, their use in analytical chemistry as reagents fits within the scope of kinetic-based determinations. Consideration to the large number of enzymatic determinations performed at clinical laboratories around the world has justified the statement that "the number (of determinations) carried out by kinetic-based methods probably exceeds that carried out by thermodynamic (equilibrium) methods and direct instrumental measurement combined."⁷

A catalyst is a chemical species that is both a reactant and product of a reaction.⁸ Its concentration enters into the kinetic equation but not into the equilibrium constant of the reaction. The presence of a catalytic cycle, as illustrated below for a generalized system, singles out catalysis from other rate-modifying effects (e.g., promotion, in which the rate modification is transitory and the modifier does not appear as a product of the reaction):

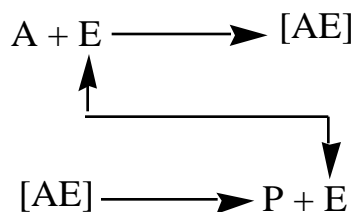

in which E is the enzyme and A a reactant, commonly known as substrate. [AE] is an intermediate species involving association between the enzyme and the substrate. The overwhelming majority of analytical methods using enzymes as analytical reagents are designed for the determination of species acting as A in the example above, that is, the substrate is the analyte under determination. There are cases, however, in which the analytical interest is the determination of the catalytic activity of the enzyme. In such cases the enzyme plays the role of analyte. In any event, a distinctive analytical advantage of using enzymes as analytical reagents is the high selectivity (even eventual specificity) of the interaction that leads to [AE] formation. Jenks,⁹ in a very interesting review, argues that specificity (and by extension high selectivity) and rate modification (the two special features of enzymatic catalysis) both derive from the utilization of the free energy made available from binding interactions with highly selective or specific substrates. Jenks qualifies further his argumentation by pointing out that "...The principal difference between enzymatic and ordinary chemical catalysis is that enzymes can utilize noncovalent

binding interactions with substrates to cause catalysis, in addition to the chemical mechanisms utilized by ordinary catalysts.”

Enzymes are proteins, and the major constituent of proteins is an unbranched polypeptide chain consisting of L- amino acids linked together by amide bonds between the -carboxyl group of one residue and the -amino group of the next. The primary structure is the sequence in which the amino acids form the polymer. Although the primary structure of almost all intracellular proteins are linear polypeptide chains, many extracellular proteins contain covalent -S-S- crossbridges that result from two cysteine residues linked by their thiol groups.¹⁰ The secondary structure of proteins is recognized as polypeptide chains organized into hydrogen-bonded structures. The three-dimensional structure of enzymes, starting from the polypeptide chains, unfolds in the tertiary structure of covalently linked polypeptide chains. There are proteins composed of subunits that are not covalently linked. The overall organization of these subunits is what is known as the quaternary structure. A change in quaternary structure indicates that the subunits move relative to each other. These three-dimensional proteinic structures are present in enzymes that can be relatively small molecules with molecular masses of the order of 10,000 Da, while others are very large molecules, with molecular masses from 150,000 to over 1 million Da. No matter what the size, chemical composition, or structure of the enzyme the catalytic action is confined to a specific region of the enzyme known as the active site, because the AE complex does not form in a topologically random manner. The substrate binds to this region on the enzyme in every catalytic cycle, and catalysis takes place only at active sites. The structure of enzymes and the unique function of the active site have resulted in an illustration of enzyme catalysis by what is known as the “lock-key” model.^{11a,11b} This simplistic model is no longer satisfactory to evaluate molecular interactions because the

physical rigidity that it conveys does not agree with a conformationally mobile enzyme-substrate interaction. It, however, does metaphorically illustrate the unique selectivity (specificity) of enzymes. Because the lock-key model does not explain all cases of enzyme catalysis, these anomalies have resulted in the postulation of revisions to the model. Koshland¹² suggested a modified model called for brevity “the induced fit” model (or theory). In essence, the induced fit model rests on: (1) a precise orientation of catalytic groups needed for enzymatic action, (2) changes in the three-dimensional relationship of the amino acids at the active site caused by the substrate, and (3) changes in the protein structure caused by the substrate to bring the catalytic groups into the proper orientation for reaction; a nonsubstrate will not do this. Figure 1 illustrates both the lock-key and the induced fit models.

The active site (or active center) is relatively small and is formed by three or four amino acids in the twisted polypeptide chain, separated considerably from each other in the amino acid sequence, but very near to each other spatially.¹³ Certain side chains of these amino acids hold or anchor the substrate at the active site, whereas others modify the bonding forces at the reacting group of the substrate. Presumably, the remainder of the enzyme proteinic structure is needed to maintain the unique conformation to form the active center. Because the catalytic activity of the enzyme depends on the presence of a given conformational structure in the folded polypeptide chain, even minor alterations in the tertiary structure result in loss of activity.¹³ Because the catalytic activity of an enzyme is proportional to the number of operating active sites at the time of the measurement, the catalytic activity for different preparations of the same enzyme may not be the same. Consequently, the analytical concentration of a given enzyme preparation cannot accurately describe the enzyme activity. This lack of correlation between concentration and activity plus the inherent

(A) "Lock-key" model of selective (specific) enzyme catalysis

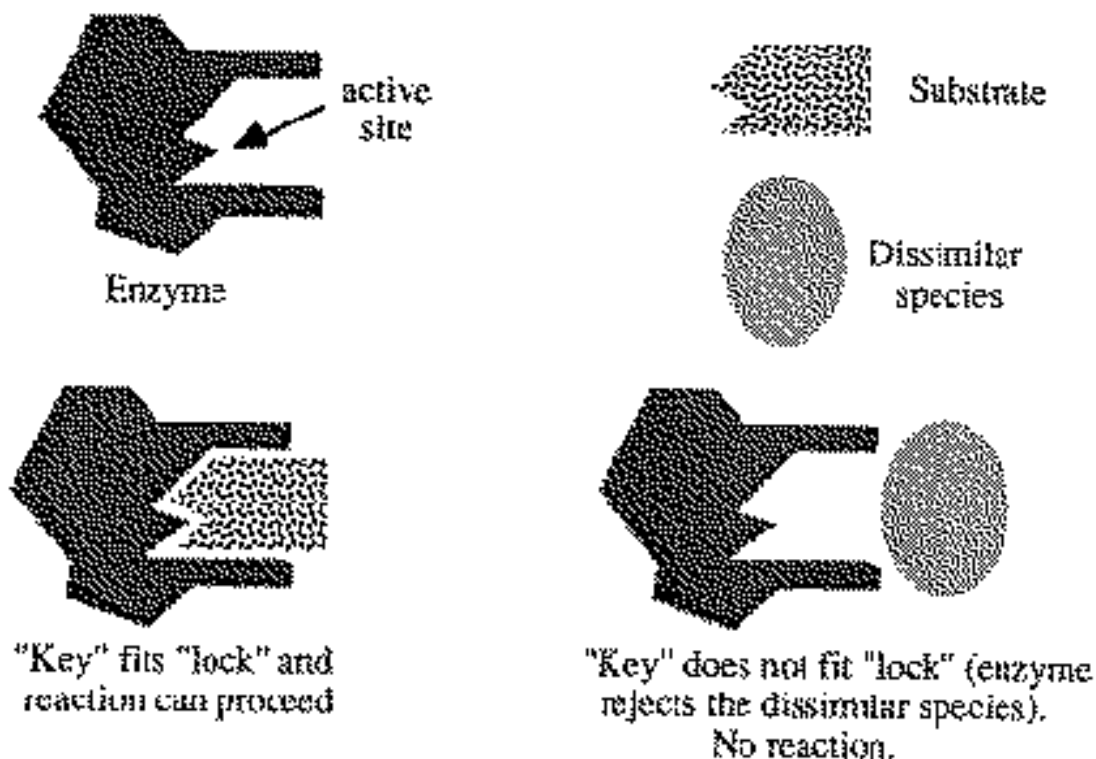

(B) Induced fit model



FIGURE 1. Models describing the relationship between the active site of an enzyme and the substrate on which that enzyme performs catalysis.

potential instability of enzyme preparations are properties that analytical chemists had to adapt to in order to use them as analytical reagents. This was not an immediate adaptation; we need to realize that gravimetry,

titrimetry, and other equilibrium-based determinations all rely on stable reagents and chemical species.

Many enzymes need the presence of other species, known as cofactors, to exert cataly-

sis. The enzyme-cofactor complex is called a holoenzyme; the proteinaceous portion is known as an apoenzyme (holoenzyme = apoenzyme + cofactor). Apoenzymes may form complexes with different types of cofactors such as: (1) a coenzyme (a non-proteinaceous organic species loosely attached to the apoenzyme), (2) a prosthetic group (an organic species firmly attached to the apoenzyme), and (3) a metallic ion.

II. GLUCOSE OXIDASE

The discovery of glucose oxidase is attributed to Müller,¹⁴ who found this enzyme in *Aspergillus niger* and *Penicillium glaucum*. Müller established in 1928 that the enzyme catalyzes the oxidation of glucose to gluconic acid in the presence of dissolved oxygen. In the same year, Bernhauer¹⁵ concluded that the conversion of glucose into gluconic acid by *A. niger* was due to an enzyme that he designated “glucosidase.” Nord and Engel¹⁶ found a similar enzyme in *Fusarium lini*. Franke et al.^{17a,17b} purified the enzyme from *A. niger* to a moderate extent, and found that the activity of different preparations was qualitatively correlated with the flavine content of the preparation. This was the first indication that the enzyme is a flavoprotein. Two years later, Müller¹⁸ studied the oxidation of various sugars in the presence and absence of oxygen, and ventured that two different enzymes were present. Somewhat earlier, Ogura¹⁹ claimed to have isolated from *A. oryzae* a glucose-oxidizing enzyme that did not utilize O₂ as the hydrogen acceptor. These dualities were put to rest by Franke,²⁰ who in 1944 concluded that the glucose oxidases from *P. glaucum*, *F. lini*, *A. niger*, and *A. oryzae* are virtually identical, consisting of a single enzyme utilizing O₂ as the hydrogen acceptor. In 1948, Keilin and Hartree²¹ cleared another confusion by demonstrating that glucose oxidase, notatin (“penicillin A”), and penicillin B are the same enzyme, which catalyzes the aerobic oxidation of glucose to

gluconic acid. These authors can also be credited as probably the first to make an analytical application of glucose oxidase in the manometric measurement of oxygen to determine glucose in some biological materials.^{22a,22b}

The purification, crystallization, and some properties of crystalline glucose oxidase from *P. amagasakiense* were reported by Kusai et al.²³ The interesting demonstration that the enzyme is a glycoprotein, besides being a flavoprotein, is due to Pazur et al.²⁴

III. PROPERTIES OF GLUCOSE OXIDASE [EC 1.1.3.4]

Glucose oxidase from *A. niger* is a dimer of 186×10^3 mol wt with two molecules of flavin adenine dinucleotide (FAD) tightly bound per dimer. The FAD in glucose oxidase stabilizes the three-dimensional structure of the enzyme and cannot be removed by dialysis at neutral pH. Evidently, the process by which FAD becomes bonded to the apoenzyme is a step in the synthesis of the holoenzyme.

Glucose oxidase is composed of two polypeptide chains of approximately equal molecular weight held together by disulfide bonds and with carbohydrate content amounting to 16%.²⁵ Recently, Chi et al.²⁶ provided pictures illustrating the first direct observation of native and unfolded glucose oxidase structures obtained by scanning tunnelling microscopy. The images show an opening butterfly-shaped pattern in accord with the general topology assigned to the structure of the enzyme. As a first step in attempting to elucidate the residues necessary for catalysis and improve the properties of glucose oxidase by protein engineering, Frederick et al.²⁷ have described the cloning and expression in yeast of *A. niger* glucose oxidase.

Some differences are observed in glucose oxidase obtained from different sources; glucose oxidase from *P. amagasakiense*, for

instance, has a mol wt of 154×10^3 and contains 2 mol of FAD per mole of proteinic enzyme.²³ Table 1, adapted from Swoboda and Massey,²⁵ illustrates the properties of glucose oxidase obtained from three different sources.

The redox mechanism of a flavoprotein oxidase such as glucose oxidase involves the

catalysis of a redox reaction. During the reaction either one or two electrons from the electron donor are transferred to the isoalloxazine nucleus of the flavin coenzyme (FAD, flavin mononucleotide [FMN], or derivative) and then to the electron acceptor.

The prosthetic group of a flavoprotein usually contributes only 0.2 to 2% of the

TABLE 1
Some Properties of Three Glucose Oxidase Preparations Obtained from Fungus (Adapted from Reference 25)

Property	Source		
	<i>Penicillium nonatum</i>	<i>Aspergillus niger</i>	<i>Penicillium amagasakiense</i>
Wavelength of maximum absorbance, (nm)	270–280, 278, 383, 452	278, 380, 460	377, 455
Inhibition by mercury	Virtually none	More than 90% by 10^{-5} M HgCl ₂ or <i>p</i> -chloromercuribenzoate	
Michaelis-Menten constant (in air, catalase present, pH 5.6)	0.033 M at 25°C	0.015 M at 30°C	0.096 M at 20°C
Molar absorptivity of enzyme flavin, 450 nm, $M^{-1} \text{ cm}^{-1}$	1.41×10^4	1.10×10^4	1.09×10^4
Formation of flavin semiquinone by dithionite	Yes	No	
Sedimentation coefficient (s) ^a	8.00	7.93	8.27
Diffusion coefficient $\text{cm}^2 \text{ s}^{-1}$ ^a	4.12×10^{-7}	5.02×10^{-7}	5.13×10^{-7}
Molecular weight	186×10^3	154×10^3	152×10^3
Standardized specific activity at 25°C ^b	80	112 ^c 77 ^c	64

^a In aqueous solution and at 20°C.

^b In units of micromoles per milligram (dry weight), "infinite" glucose concentration, 0.25 mM oxygen, excess catalase, and phosphate or acetate buffer of pH 5.60.

^c The values of 112 and 77 are from References 23 and 24, respectively.

Data from References 22a, 22b, 24, 29.

total molecular weight. Because of the variety of chemically active residues in these groups, multiple stabilizing bonds are formed between the prosthetic group and the rest of the proteinic framework.²⁸ The flavin nucleus exists in three oxidation states, each of which can adopt different states of ionization. Figure 2 illustrates the redox and acid-base behavior of these flavin species. As Figure 2 shows, the three states of ionization involve the proton on N-3 for HF_o and the proton on N-1 in both H₂F and H₃F_r.²⁹ The R group at N-10 is either FAD or FMN.

Glucose oxidase should be defined as an oxidoreductase that catalyzes the reaction by which all electrons taken from the substrate (glucose) are transferred to O₂ to form H₂O₂. Catalysis by this flavoprotein depends on the reduction-oxidation of its flavin group.

The mechanism of the overall process is postulated to include an oscillation between the oxidized and the reduced forms of the flavin:³⁰

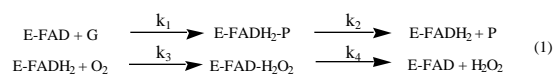

Glucose, G, reduces the FAD to FADH₂ without the formation of the free radical semiquinone as intermediate and produces gluconic acid, P, as product. Subsequently, oxygen, the acceptor, oxidizes the FADH₂ back to FAD and H₂O₂ is released as product.

Keilin and Hartree,^{22b} in their pioneering studies of glucose oxidase, report that the enzyme does not fluoresce under ultraviolet light within the pH limits in which it has catalytic activity (pH 2.0 and 8.0). Outside this range, however, glucose oxidase loses

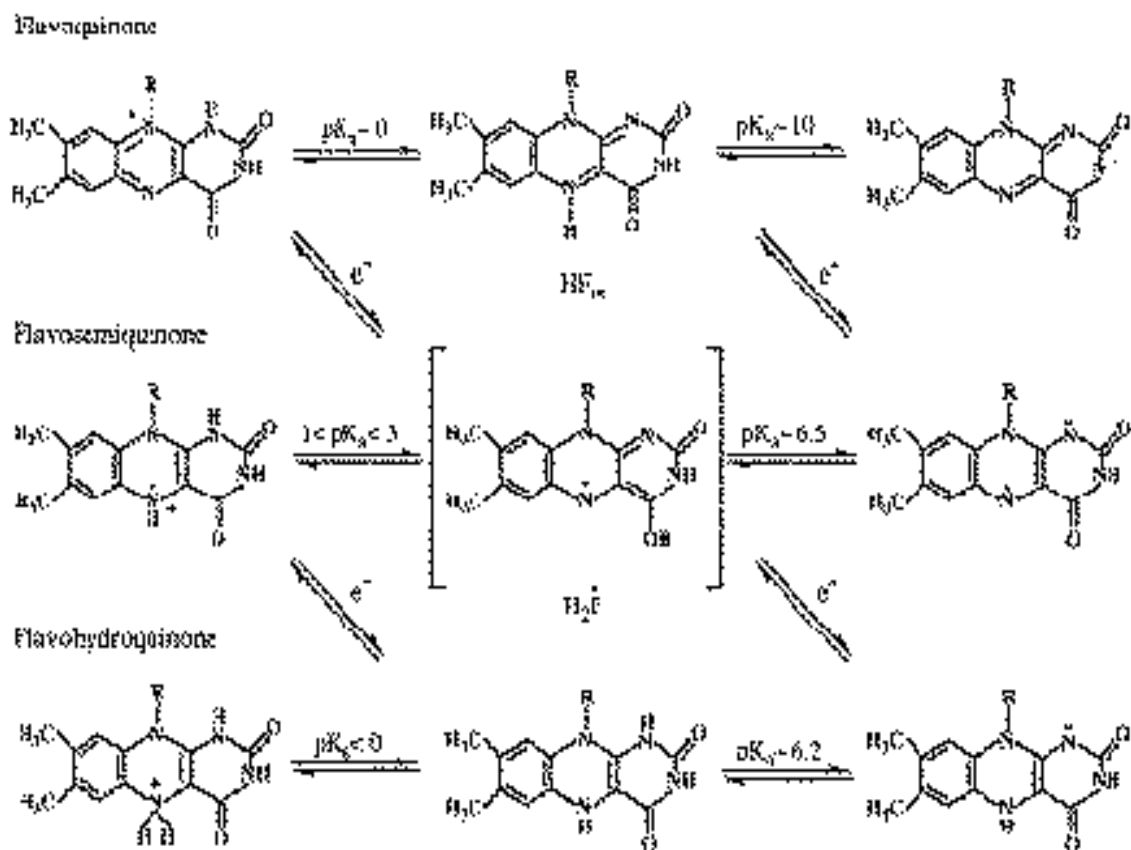

FIGURE 2. Flavin species as they occur at different pH and oxidation states.

activity and becomes fluorescent. According to Gibson et al.,³¹ glucose oxidase shows catalytic activity over the pH range from 3.0 to 10.0 (maximum seems to center at ca. pH 5.5) as the result of the rather unusual stability of this enzyme.

Using a flow apparatus and spectrophotometric detection, Nakamura and Ogura³² studied the kinetics of catalysis by the glucose oxidase from *P. amagasakiense*, and identified as rate limiting the step corresponding to the conversion of the glucose-enzyme complex to reduced enzyme and products. Gibson et al.³¹ convincingly reported on the mechanism of catalysis by glucose oxidase from *A. niger*. They employed stopped-flow mixing and manometric measurements at a pH of 5.6 and in the 0 to 38°C temperature range. They found no evidence of a kinetically significant flavin-semiquinone intermediate, and all their kinetic data can be analyzed in terms of the distribution of the enzyme in two forms: the fully oxidized and the fully reduced (Figure 2). The results from all the sugar substrates tested fit the general scheme of Equation 1 comprising a reductive half-reaction and an oxidative one. Several other kinetic studies^{33a-33f} tend to confirm the findings of these earlier reports.

The enzyme is highly selective toward α -D-glucose²¹ (Table 2), and any chemical alteration departing from the basic molecular structure of this species results in substrates with considerably reduced reactivity in the presence of glucose oxidase as the catalyst. The β -anomer reacts about 150 times as fast (at 20°C) as the α -anomer of D-glucose. Substitution on C-2 (except of -H for -OH) or on C-3 erases all catalytic activity, but substitution on C-4 and C-6 considerably decreases but does not totally eliminate the catalytic activity of the enzyme toward the corresponding substrates. This high selectivity, obviously, singles out glucose oxidase as a unique analytical reagent for the determination of glucose in general and α -D-glucose in particular.

TABLE 2
Relative Oxidation Rates, in the Presence of Glucose Oxidase as Catalyst, for Several Sugars^a

Sugar	Relative rate of oxidation
α -D-glucose	100
2-Deoxy-D-glucose	25
6-Deoxy-6-fluoro-D-glucose	3
6-Methyl-D-glucose	1.85
4,6-Dimethyl-D-glucose	1.22
D-mannose	0.98
D-xylose	0.98
β -D-glucose	0.64
Tetralose	0.28
Maltose	0.19
Galactose	0.14
Melobiose	0.11

^a Rates are normalized to the rate of α -D-glucose oxidation and for the general reaction: sugar + O₂ corresponding acid + H₂O₂.

IV. ANALYTICAL USES OF GLUCOSE OXIDASE

Considering its price per unit activity, glucose oxidase is one of the less expensive enzymes for analytical use as a reagent, particularly when its inherent competitive stability is also taken into consideration. Historically, its use in solution preceded its analytical use in immobilized form. The main argument for immobilization is the recovery of the enzyme for repetitive use as a reagent. In actuality, however, if an enzyme is relatively inexpensive and relatively stable (so that it retains its activity toward the substrate of interest at reasonably constant level at room temperature with time), it can be used directly and competitively in solution for repetitive determinations.⁶ Competitive use is afforded by implementation of unsegmented closed-loop continuous-flow systems.³⁴ The virtue of using glucose oxidase in solution has also been argued and demonstrated in connection with open-loop automated unsegmented continuous-flow con-

figurations.³⁵ Why then, is glucose oxidase used so extensively in immobilized form? The fashionable use of packed-column reactors in unsegmented-continuous-flow systems (e.g., in flow injection analyses) and the ease of immobilization of glucose oxidase undoubtedly play some role. Of greater impact is perhaps the convenience of immobilized glucose oxidase and the oxidation of glucose to gluconic acid as a model system for the development and characterization of new analytical approaches (e.g. new reactor configurations or strategies in so-called “biosensing”). As such, in the remainder of this review, we will address the following themes: (1) the use of glucose oxidase as an analytical reagent in solution, (2) the use of immobilized glucose oxidase for determinative purposes (including the use of glucose oxidase in model systems for method or approach development), and (3) the determination of glucose oxidase activity.

V. USE OF GLUCOSE OXIDASE AS AN ANALYTICAL REAGENT IN HOMOGENEOUS SYSTEMS

In 1956 Keston³⁶ proposed the first practical analytical application of glucose oxidase as a homogeneous as well as a heterogeneous biocatalyst. In 1959 Marks³⁷ suggested that older, nonselective, methods be replaced by enzymatic ones. The bulk of these enzymatic methods, for obvious reasons, are kinetic (rate-based) methods. The chemistry of the enzyme-catalyzed reaction primarily dictates the approach (including instrumentation) to be used in monitoring the reaction rate. In the case of glucose determination, each chemical species involved (except of course the analyte itself and the biocatalyst) has been used to provide the means for determination. Table 3 gives a summarized overview of the typical detection approaches used in the enzymatic deter-

TABLE 3
Typical Detection Approaches Used in the Enzymatic Determination of Glucose Using Glucose Oxidase

Chemical species responsible for detection	Coupled process to aid detection	Detection approach
H ₂ O ₂	None	Amperometric
	Oxidation of an indicator species	
	(a) organic dye	Spectrophotometric
	(b) Fe(CN) ₆ ³⁻	Amperometric or spectrophotometric
	Oxidation of a chemical species leading to fluorescence	Fluorometric
	Oxidation of a chemical species leading to chemiluminescence	Chemiluminometric
	Oxidation of a chemical species resulting in a change in potential of the system under observation	Potentiometric
O ₂	None	Amperometric
Gluconic acid	None	pH-stat (potentiometric)

mination of glucose using glucose oxidase. It should be noted that the information given in this table, in general, applies equally well to soluble or immobilized glucose oxidase.

Keston's proposal³⁶ for using glucose oxidase in solution to determine glucose in urine samples involved spectrophotometric measurement (480 nm) of the colored product of *o*-dianisidine (3,3 -dimethoxybenzidine) oxidation in the presence of glucose oxidase and peroxidase. This coupling of the main enzyme-catalyzed reaction with a second (indicator reaction) has become a very common practice in enzymatic methods. Because reactions involving oxidases yield H₂O₂ as one of their products, the oxidizing power of H₂O₂ is exploited in such coupled schemes. The oxidation of the reduced form of the dye is aided by the action of peroxidase:

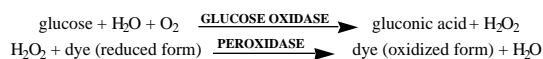

Keston³⁶ also proposed the determination of glucose in urine by impregnating paper strips with glucose oxidase, peroxidase, and *o*-toluidine (3,3 -dimethylbenzidine) as a chromogenic oxygen acceptor. Strips of filter paper impregnated with the appropriate reagents are dried in air and stored protected from light. The reagent papers are dipped into the test solution, removed, and compared (after a minute or two) with colors produced by standard glucose solutions. In these tests the glucose oxidase enzyme can be considered immobilized (by physical adsorption) on the filter paper support. Keston's proposal has been widely adapted for the determination of glucose in clinical, food, and agricultural analysis and the literature records numerous applications involving minor variations to the original conditions. Different dyes, for instance, have been proposed in place of *o*-dianisidine; some typical examples include 2,6-dichlorophenolindophenol,³⁸ *o*-toluidine,³⁹ guaiacum (guaiac or guaiacum resin obtained from

the wood of *Guaiacum officinale* and *Guaiacum sanctum*; Chemical Abstract Service Registry Number 900-29-7; Merck Index No. [11th ed., 1989] 4455),⁴⁰ 2,2 -azino-di-[3-ethylbenzthiazoline-6-sulfonic acid] (ABTS),^{41a,41b} 4-aminophenazone or adrenaline,⁴² in situ coupling of 3-methyl-2-benzothiazolinone hydrazone with *N,N*-dimethylaniline,^{41a} oxidative coupling of *N,N*-diethylaniline with 4-aminophenazone or phenol,⁴³ and leuco Patent Blue Violet.⁴⁴

The quest for alternative dyes was in great part motivated by the fact that the use of *o*-dianisidine may expose those using it to long term-health problems. ABTS, with an absorption maximum at 420 nm, is a very convenient chromogen because it is safe, very soluble in water, practically insensitive to light, and does not undergo autooxidation. Moreover, it is more sensitive for H₂O₂ detection than *o*-dianisidine. Regarding the chemical performance of the most commonly used dyes in enzymatic determinations with glucose oxidase, however, the results are comparable and the enzymatic-based methods are competitive with previously well established methods.⁴⁵⁻⁴⁷ Readers interested in optimal conditions for the use of glucose oxidase in solution to directly determine glucose in plasma and urine, and without preliminary preparation of protein-free filtrates, are referred to the work of Kingsley and Getchell.⁴⁸

The availability of improved electronic devices led to the development of automatic methodologies in the 1960s. Malmstadt and Hicks,⁴⁹ for instance, assembled an instrument from commercially available units and interfaced it with a control system and enzyme injector. The commercially available unit was the Spectro section of the Spectro-Electro titrator (E.H. Sargent & Co., Skokie, IL). The practical end was to shorten to about 1 min the clinical determination of glucose based on glucose oxidase catalysis by spectrophotometric monitoring of H₂O₂ released by oxidation of a dye. One year later,

Malmstadt and Pardue^{50a,50b} introduced a potentiometric reaction rate method in which the H_2O_2 formed during the enzyme-catalyzed reaction reacts with an excess of iodide, in the presence of molybdate as the catalyst, and produces an equivalent amount of iodine. In this paper the applicability of the variable-time procedure⁵¹ to nonlinear response curves is demonstrated. A spectrophotometric variant of the same method (measurement of the absorbance of I_3^- at 360 nm) was proposed by Malmstadt and Hadjiioannou 1 year later.⁵² The same chemistry was utilized by Pardue⁵³ to introduce amperometric monitoring for continuous measurement of reaction rates. The rate of increase in iodine concentration was measured using a polarized rotating platinum electrode (polarizing source: a 1.5-V battery in series with a 100- Ω potentiometer; rotation velocity: 2000 rpm). The approach was applied to the determination of glucose in serum, plasma, and whole blood.

An ingenious piece of work was described by Blaedel and Hicks⁵⁴ in what constitutes the first implementation of unsegmented continuous-flow sample/reagent(s) processing for the measurement of the rate of an enzyme-catalyzed reaction in a continuous fashion. This paper describes a flow system that permits determinations using the fixed-time approach. As an extension of this continuous-flow approach, the same glucose determination was used by Blaedel and Olson,⁵⁵ to introduce a setup that allows the continuous measurement of reaction rates. The measurement involved a differential amperometric procedure in which the H_2O_2 produced oxidizes hexacyanoferrate(II) to hexacyanoferrate(III), the concentration of the latter measured at a tubular platinum electrode. However, when enzymes are used as analytical reagents for the determination of substrates, their catalytic nature indicates that repetitive use should be possible. Immobilization is an avenue that moves in that direction. Enzyme regeneration in homoge-

neous systems is, however, possible. Reagent recirculation in closed flow-through systems^{34,56} permits the reutilization of soluble enzyme preparations. An example of implementing recycling of the enzyme solution, sample injection into a closed flow-through system, and amperometric detection of the change in dissolved oxygen level as a result of the oxidation of glucose to gluconic acid in the presence of glucose oxidase has been offered for glucose determination.³⁴ The H_2O_2 released in this reaction interferes with the monitoring of O_2 . This is circumvented, however, by using glucose oxidase that contains catalase as an impurity, which is inexpensive and ensures practically instantaneous destruction of the H_2O_2 formed. The oxygen produced by this reaction is one half the oxygen consumed in the main catalyzed reaction, and monitoring based on oxygen consumption is still possible.

Although the bulk of the proposed methods for glucose using glucose oxidase utilizes spectrophotometric monitoring, the reaction can be followed electrochemically (by monitoring amperometrically the H_2O_2 formed or the O_2 consumed^{34,57-59}) or potentiometrically. Kadish and Hall⁵⁷ compared results obtained with a polarographic oxygen sensor with standard AutoAnalyzer data. The compared population data contained 1,056 pairs of points obtained over a 5-month period. They measured the decrease in dissolved oxygen and used iodide, ethanol, and ammonium molybdate to minimize problems claimed to be associated with the H_2O_2 produced.

A special consideration of continuous-flow systems and the so-called AutoAnalyzer technology seems necessary at this point of the review. Continuous-flow procedures have provided advantageous alternatives for wet chemical methods. The practice of wet chemical analysis has undergone drastic changes, particularly since the mid-1950s when Skeggs^{60,61} proposed a novel manner of sample-reagent mixing and transport to

detection. The elements of Skeggs's modular, continuous-flow concept resulted in the workhorse of practically every clinical laboratory and many industrial analytical facilities, the so-called AutoAnalyzer developed and marketed by Technicon (Technicon Instruments Corp., Tarrytown, NY). Methods for glucose using the AutoAnalyzer were developed in the late 1960s and early to mid 1970s using hexacyanoferrate(III), hexokinase, neocuprione, *o*-toluidine, and glucose oxidase.⁶²

Monitoring of the reaction has involved detection based not only on the O₂ consumed or the H₂O₂ formed, but in the change in pH resulting from the conversion of glucose to gluconic acid, if low ionic strength buffers are used. Malmstadt and Piepmeier,⁶³ as part of the electronic impact of the mid 1960s, described a pH-stat with digital readout that they used to develop a method for glucose determination in the 50 to 250 ppm range. In this procedure the pH was held constant at 6.5 by adding small (equal) increments of 0.0020 M NaOH; the number of aliquots of reagents delivered during a preset time was counted. The count proved to be directly proportional to the glucose concentration. The approach is very reproducible but lacks the sensitivity of methods based, for instance, on the coupling of reactions based on H₂O₂ production. Guilbault et al.,⁶⁴ on the other hand, proposed a potentiometric rate-based method monitoring the main reaction by recording the change in the difference in potential between two platinum thimble electrodes polarized with a constant current of 40 μA. The method was developed for the determination of either glucose or glucose oxidase itself. Diphenylaminesulfonic acid with a reported "transition" potential of +0.8 V vs. the NHE was used for establishing the initial potential. The rate of potential change after addition of the sample provided the bases for calibration plots. Another twist in coupling the main enzyme-catalyzed reaction with a second chemical-indicating

system can be seen in the proposal of Alexander and Seegopaul⁶⁵ for using a potentiometric SO₂ probe to monitor the H₂O₂ production by the progress of the following reactions:

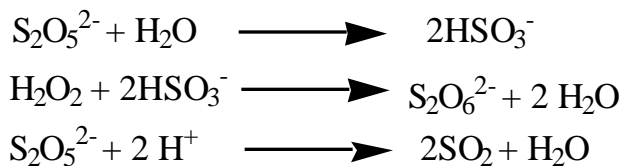

Because of glucose relevance in patients' demographic information via normal/abnormal test results, it is not surprising that clinical applications of glucose oxidase as an analytical reagent outweigh applications in other areas. Glucose, as already mentioned in this review, plays an important role in foods and the food industry, and applications to the analysis of food products abound. White,⁶⁶ for example, determined glucose in honey by a photometric procedure in which the glucose oxidase used was contaminated with α-glucosidase (invertase) but the interference was circumvented by inhibition working in a Tris [tris-(hydroxymethyl)-aminomethane] buffer. Results (accuracy and reproducibility) were comparable to those of recognized standard methods.

As indicated in Table 3, the H₂O₂ can be used to effect different changes on coupled chemical species. Some of these changes are physicochemical transformations that result in the formation of an excited chemical species that, after relaxing to its ground state emits radiant energy (fluorescence or chemi-/bioluminescence). Guilbault et al.,⁶⁷ for example, proposed the oxidation of homovanillic acid (4-hydroxy-3-methoxyphenylacetic acid) by the H₂O₂ to produce a highly fluorescent product. In a subsequent paper they evaluated 25 indicator species for the same fluorometric determination.⁶⁸ They concluded that *p*-hydroxyphenylacetic acid constitutes the best target species because it is less expensive and provides a higher "fluorescent coefficient" (fluorescence intensity/

molar concentration). The procedures are also illustrated for the determination of enzyme activity. Leucodiacyldichlorofluorescein, originally synthesized by Brandt and Keston^{69a} and proposed as a fluorophor for H₂O₂ determination by the same authors,^{69b} was used by Kelly and Christian.^{70a,70b} The H₂O₂ (in the presence of horseradish peroxidase) produces fluorescent dichlorofluorescein (excitation at 448 nm, emission at 525 nm). Keston et al.,⁷¹ however, reported photons of 500 nm as the best excitation wavelength. Excitation was accomplished with an argon ion laser and the instrumental setup involved a capillary sheath cell and continuous-flow processing. Air-segmented continuous-flow processing for collecting data and stopping the flow was used by Hsieh and Crouch⁷² in a kinetic method for determining glucose with the Trinder reaction⁷³ in the presence of glucose oxidase. Using this approach glucose was determined in wines and serum samples. An unsegmented continuous-flow/stopped-flow/continuous-flow system has also been reported.⁷⁴ The sample and enzyme solution are simultaneously injected and a gas-permeable silicone-rubber reaction coil (to enhance mixing) as well as pulsed amperometric detection of H₂O₂ were employed. In continuous-flow systems, mixing can also be enhanced by the use of what has been termed a "single bead string reactor."⁷⁵

Chemi- and bioluminescence provide kinetic-based methods involving measurements under dynamic conditions of transient light emission (Chapter 8 in reference 51). Their amenability to the determination of species of biomolecular interest and a relatively simple implementation have resulted in a considerable increase in popularity in the past 10 years or so,⁷⁶ popularity that continues as sustained application.⁷⁷ Enzymatic chemiluminescence determination of glucose, of course, did not escape this popularity. A review is available in which the advantages and disadvantages of chemi- and

bioluminescence determinations in clinical chemistry have been considered.⁷⁸ Luminol (5-amino-2,3-dihydrophthalazine-1,4-dione) has found several analytical applications and is perhaps the most commonly used luminophore in chemiluminescence determinations. Because H₂O₂ is commonly used as an oxidizing agent in luminol chemiluminescence, it is not surprising that *in situ* generation of this reactant via glucose oxidation aided by glucose oxidase is also commonly used. Auses et al.⁷⁹ proposed the determination of glucose by coupling the H₂O₂ produced with the oxidation of luminol in the presence of Fe(CN)₆⁻³ as a rate promoter. The high pH conditions required in the luminol/H₂O₂ reaction (pH 10 to 11) are not compatible with the relatively mild pH (ca. pH 7.00) needed for efficient functioning of most enzymes as biocatalysts. An alternative approach that successfully overcomes the pH mismatch has been proposed.⁸⁰ The presence of an inverted (reversed) micellar medium of hexadecyltrimethylammonium chloride permits the enzymatic and chemiluminescence reactions to take place simultaneously at a mild pH (7.8) and in the absence of rate modifiers. The reversed micellar bulk solvent was a 6:5 (v/v) mixture of chloroform and cyclohexane.

An interesting strategy to the use of glucose oxidase in solution for the determination of glucose, avoiding the pH mismatch, was advanced in 1982 by Pilosof and Nieman.^{81a} In an unsegmented continuous-flow system, the enzyme solution is separated from the flow of other reagents and sample by a microporous membrane. The glucose solution is allowed to flow, under pressure, through the membrane, acting as a containment barrier, and a pH gradient is created into the flow cell. A 0.10 M phthalate buffer carries the enzyme through the membrane and assures a pH of 5.0 adjacent to the membrane wall, which is close to the optimum for the enzyme-catalyzed reaction. The sample is carried by a 0.50 M KOH

solution containing the luminol and tris[1,10-phenanthroline]copper(II) as a rate promoter. The pH in the bulk of the solution close to the optical window for chemiluminescence measurement is about 11, optimal for the chemiluminescence reaction between luminol and the H_2O_2 released in the enzyme-catalyzed step. If immobilization is defined in a general form as the "localization or confinement of a reagent,"⁸² this contribution could be grouped with other applications utilizing other forms of immobilized glucose oxidase. We have opted in this review, however, for the more restrictive definition of immobilization in which the immobilized reagent is insoluble in the medium, and the inclusion of this strategy in this section of the review. The same applies to a contribution by Chang et al.⁸³ in which an outer silicone membrane (for oxygen supply) and an inner polyamide membrane (for substrate permeation) were used as an "immobilized enzyme reactor" for glucose determination. The glucose oxidase is used, however, in solution and contained between a silicone tube and a sponge layer.

Species other than luminol and which also lead to chemiluminescence for determination of glucose have been proposed. Williams et al.,⁸⁴ for example, utilized (2,4,6-trichlorophenyl)oxalate in a mixed ethyl acetate-methanol-aqueous buffer system.

The use of glucose as an analytical reagent is nearly monopolized by glucose as the analyte. Few examples in which glucose oxidase acts as an analytical reagent for species other than glucose can, however, be cited. Toren and Burger⁸⁵ studied the inhibitory effect of metal ions such as silver, mercury, and lead on the activity of the enzyme and developed indirect methods for determination of these species. The indicator reaction was the classical *o*-dianisidine (in presence of peroxidase) and photometric monitoring at 440 nm was used. Silver(I) was determined in the 0.005 to 0.2 $\mu\text{g}/\text{ml}$ range, mercury (II) in the 0.1 to 0.4 $\mu\text{g}/\text{ml}$

range, and concentrations of lead(II) greater than 260 $\mu\text{g}/\text{ml}$ are needed for inhibition. Considerably lower concentrations of lead (II), however, seem to be amenable to determination using inhibition of peroxidase and fluorescence monitoring.⁶⁷ The determination of molecular oxygen dissolved in aqueous and nonaqueous solvents is another example of the use of glucose oxidase for the determination of a chemical species other than glucose. Ghosh et al.⁸⁶ proposed such a determination by using an excess of glucose and determining the glucose consumed by a glucose oxidase procedure⁸⁷ involving peroxidase and *o*-dianisidine. After mixing the excess glucose with the glucose oxidase and *o*-dianisidine (peroxidase was also present), bubbling with N_2 (*g*) was effected for 5 to 7 min, the sample was incubated at 37°C for 30 min, the enzyme remaining active inactivated by heating at 100°C for 4 min, and finally the glucose consumed determined. The method is elaborate and more straightforward means of determining dissolved oxygen are available; its mention here is only to point to other uses of glucose oxidase than for glucose determination. The glucose oxidase-catalyzed oxidation of glucose by dissolved oxygen has also been used as a coupled indicator reaction for the determination of other chemical species producing D-glucose in their main enzyme-catalyzed reaction. Starch, maltose, and lactose, for instance, have been determined in a variety of food products by using this approach.^{88a,88b}

An interesting twist to the use of glucose oxidase (and any other enzyme) in solution has been provided by Thompson et al.⁸⁹ They developed a strategy for the determination of glucose in whole blood employing, in immobilized form, the dye of the indicator reaction. The covalently immobilized dye used was 3-hydroxyphenylacetic acid, and the inert matrix for immobilization was provided by micron-size porous glass beads. Glucose oxidase and horseradish peroxidase

in solution catalyzed reactions that resulted in converting the immobilized species into a surface-bound red quinoneimine dye, and detection involved diffuse reflectance spectrophotometry.

VI. ANALYTICAL APPLICATIONS OF IMMOBILIZED (INSOLUBLE) GLUCOSE OXIDASE

Immobilization refers here to the localization or confinement of a given chemical species in such a manner that it remains physically separated from the substrate solution and the products of the enzyme-catalyzed reactions. The biocatalyst is in insoluble form in the medium, and heterogeneous biocatalysis occurs in a restricted space in which diffusional considerations play a more critical role than in homogeneous catalysis. The four most common methods of enzyme immobilization involve:⁹⁰ (1) containment by a membrane, (2) entrapment in a polymeric gel matrix, (3) surface immobilization by physical adsorption, and (4) surface immobilization by covalent binding. Containment by a membrane and gel entrapment find use in the construction of the so-called enzyme electrodes and biosensors, and applications of covalent binding outweigh those using physical adsorption, although physical adsorption or containment by membranes is prevalent in early developments. Basic and applied aspects of enzyme immobilization can be consulted in pertinent monographs.^{90-92c}

The use of insoluble glucose oxidase provides some advantages that overcome limitations encountered when using the soluble enzyme in solution. For example, (1) there is some increase in the retention of enzyme activity with time, (2) easy separation and recovery are accomplished with minimum (if any) contamination of the enzyme preparation by reactants and products, and (3) the insoluble enzyme preparations are ubiquitous in the design of reactor/sens-

ing units and are adaptable to continuous-flow sample and reagent processing. In view of this ubiquity, this part of the review focuses on the use of insoluble glucose oxidase in (1) reactors located at some distance from the detection system and (2) reactors integrated with the detection unit. The overwhelming use of external reactors is realized in the form of packed reactors in unsegmented continuous-flow processing (e.g. flow injection analyses). Integrated reactor/detection units appear predominantly in what is denominated as biosensors. The same type of detection (electrochemical, optically aided [e.g., photometric], or enthalpimetric), however, can be used with either of the two strategies; therefore, the focus here is on the location of the enzyme reactor and its characteristics.

VII. GLUCOSE OXIDASE REACTORS LOCATED AT A DISTANCE FROM THE DETECTOR

The immense majority of applications utilizing reactors located at some distance from the detector comprise flow systems, particularly the so-called flow injection analyses. Monographs on the topic provide the background for interested readers.^{93a,93b} Short reviews focused on reactors of this type are also available.^{82,94} In essence, most of them involve short (1 to 3 cm in length) reactors of small diameter (0.5 to 2 mm i.d.) packed with the immobilized enzyme preparation. In a few cases the column contains a single-bead string packing with the enzyme immobilized on the beads, or is located in the sample loop of the injection valve.⁸² Also in a few examples, the enzyme was directly immobilized on the walls of the reactor. The packed column located after injection in the continuous-flow manifold is, however, the most commonly used variation, although this simple approach does not fully utilize the potential of the immobilized enzyme

preparation.^{95a,95b} Table 4 is a selective compilation of the reactors containing immobilized glucose oxidase located at a certain distance from detection and involving packed column or open column reactors. Also included at the end of Table 4 is a sample of miscellaneous reactors in which the bio-reactor part is located close to the point of detection.

VIII. GLUCOSE OXIDASE REACTORS INTEGRATED WITH THE DETECTOR

A. Electrochemical Sensing

Since the basic concept of an enzyme electrode was first described by Clark and Lyons in 1962,¹³³ there has been an impressive proliferation of biosensing design using glucose oxidase. The first glucose oxidase enzyme electrode was described by Updike and Hicks¹³⁴ and was designed for the continuous measurement of blood glucose. Actually, it was Updike and Hicks who coined the term enzyme electrode, a questionable designation because these electrodes are not used for the determination of enzyme activity and the electrode per se is not made of enzyme.¹³⁵ In any event, the reactor/electrode designed by these authors was based on the amperometric measurement of O₂ (g) depletion in an immobilized glucose oxidase gel of uniform particle size. The enzyme reactor part is a glucose oxidase enzyme entrapped within an acrylamide gel membrane prepared by mixing, at pH 7.4, the soluble enzyme preparation with solutions of acrylamide and *N,N*-methylenebisacrylamide in 0.10 M phosphate buffer.

An interesting variation afforded by electrochemical measurement was described by Williams et al.¹³⁶ They proposed to use benzoquinone instead of oxygen in the main enzyme-catalyzed reaction and based the electrochemical measurement on oxidation

of the hydroquinone formed. Thus, the electrochemical strategy is based on the following reactions:

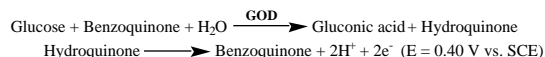

Because the quinone is regenerated in the electrochemical half-reaction, the concentration of the oxidant is for all practical purposes constant, a property of kinetic significance. The authors proposed a reactor/detector system "composed of the electrochemical sensor (platinum electrode), enzyme reaction layer (enzyme trapped in porous or jelled layer), and diffusion and dialysis layer (e.g., dialysis membrane)." A 0.006-in., 100-mesh nylon screen was used as the porous structure to entrap the enzyme solution, and the diffusion barrier was provided by a cellophane film.

Amperometric reactor/detector units have been classified as follows:¹³⁷ (1) *first-generation units*, based on the detection of H₂O₂ or oxygen consumption, (2) *second-generation units*, which employ an electron mediator to facilitate electron communication between the active site of the enzyme and the electrode surface, and (3) *third-generation units*, which make use of special electrode materials allowing direct electron transfer between enzyme and electrode. This classification was used as the basis for evaluating glucose electrodes for the determination of glucose in whole blood by Gunasingham et al.¹³⁸ Guilbault and Lubrano^{139a,139b} attached a glucose oxidase reactor layer to platinum used as an anode for H₂O₂ detection. The reactor layer was glucose oxidase physically entrapped in a polyacrylamide gel. Glucose oxidase can also be physically immobilized by direct admixing in a carbon paste formulation for amperometric measurements in continuous-flow systems.¹⁴⁰

Shu and Wilson¹⁴¹ have attached glucose oxidase to carbonaceous rotating electrode surfaces. The bioreacting surface was pre-

TABLE 4
Selected Examples of Reactors Containing Immobilized Glucose Oxidase

I. Reactors located after sample introduction but before detection in continuous-flow manifolds

Spectrophotometric detection

Reactor type	Comments	Ref.
Packed	A 1-ml disposable syringe packed with glucose oxidase immobilized on polyacrylamide gel used as reactor; unsegmented continuous-flow system; glucose determination used to characterize the system	96
Open	Glucose oxidase covalently attached to the inner wall of a coiled diazotized polyaminostyrene tube (375 cm long, 0.2 cm i.d.); air-segmented continuous-flow system	97
Packed and open	Glucose oxidase covalently attached to type 6 nylon powder, membrane, and tubing (1-mm bore); glutaraldehyde attachment; air-segmented continuous-flow system for glucose determination	98
Open	Tubular glucose oxidase wall reactors; air-segmented continuous-flow system	99a, 99b, 99c
Open	Glucose oxidase physically entrapped between two dialysis membranes and the resulting reactor located in the dialyzer unit of a Technicon air-segmented analyzer	100
Packed	Enzyme covalently bound to controlled-pore glass; air-segmented continuous-flow system	101
Open	Enzyme immobilized on the walls of a hydrolyzed nylon tubing; the reactor is intercalated in one of the arms of a stopped-flow mixing unit, and between the push liquid syringe and the flow cell; the second arm of the unit is used to deliver the indicator reagents (iodide and Mo[VI])	102
Packed	Two packed column reactors in tandem, one containing glucose oxidase and the other horseradish peroxidase; both enzymes immobilized on controlled-pore glass	103
Packed	The system was designed for the determination of dissolved oxygen; the effluent from the reactor (the glucose-glucose oxidase system acts as indicator) is merged with a chromogen and fed into a second packed reactor with immobilized peroxidase	104
Packed	Glucose oxidase immobilized on a single-bead-string reactor for the study of the kinetics of D-glucose mutarotation	105
Packed	Enzyme immobilized on glass beads; on-line monitoring of glucose for control of fermentation processes	106
Packed	Glucose oxidase and peroxidase immobilized on controlled-pore glass and packed in the same reactor; different flow programming evaluated	107

TABLE 4 (continued)
Selected Examples of Reactors Containing Immobilized Glucose Oxidase

I. Reactors located after sample introduction but before detection in continuous-flow manifolds

Electrochemical detection

Reactor type	Comments	Ref.
Packed	Enzyme-gel capillary column; glucose oxidase entrapped in the gel matrix by photocatalytic polymerization of acrylamide and <i>N,N</i> -methylbis-acrylamide; Clark-type oxygen electrode used for detection	108
Packed	Closed-loop recirculating system; Enzyme immobilized on a water-insoluble carrier; oxygen detection	109
Packed	Enzyme immobilized on controlled-pore glass; monitoring of dissolved O ₂ using Clark-type electrode	110a, 110b
Open	Glucose oxidase immobilized on a nylon tube activated by alkylation with dimethyl sulfate using amine and glutaraldehyde spacers; monitoring of dissolved oxygen	111
Packed	Glucose oxidase covalently immobilized on porous alumina; amperometric monitoring of H ₂ O ₂	112
Packed	Glucose determination in plasma; glucose oxidase immobilized on controlled-pore glass; hydrogen peroxide amperometrically detected in a flow-through cell with two Pt electrodes with a 0.60-V potential difference	113
Packed	Glucose oxidase immobilized on controlled-pore glass by using an immunological reaction; unsegmented continuous-flow system; hydrogen peroxide monitoring; glucose determination	114
Packed	Determination of sucrose by converting to glucose in a reactor containing immobilized glucose isomerase and glucose oxidase; in series reactors containing the enzymes separated also described; amperometric monitoring of dissolved oxygen	115
Packed	Continuous monitoring of glucose; a microdialysis fiber used to withdraw the sample; after passing through the fiber, the perfusion liquid entered a microreactor with glucose oxidase immobilized on controlled-pore glass; electrochemical monitoring of dissolved oxygen levels	116
Packed	Glucose determination; glucose oxidase immobilized on aminopropyl-derivatized controlled-pore glass and packed in a polycarbonate tube; continuous-flow system and amperometric detection of H ₂ O ₂ with a wall-jet electrode	117

TABLE 4 (continued)
Selected Examples of Reactors Containing Immobilized Glucose Oxidase

I. Reactors located after sample introduction but before detection in continuous-flow manifolds

Electrochemical detection

Reactor type	Comments	Ref.
Membrane	Glucose oxidase immobilized on poly(2-hydroxyethyl methacrylate) membranes by entrapment and polymerization of a coat of hydroxyethyl methacrylate; this resulted in a "sandwich" with glucose oxidase in the center with high loading and enzyme activity	118
Packed	continuous-flow system and monitoring of dissolved oxygen; potential application for glucose determination Enzyme immobilized with near 100% efficiency onto 10- μ m tresyl-activated silica beads (1000 to 500 Å pore size); bead slurry packed into 2- \times 20-mm columns; columns stable for more than 40 d; limit of detection for glucose in the picomole range; amperometric detection	119

Luminescence detection

Reactor type	Comments	Ref.
Packed	Glucose oxidase immobilized on Sepharose and packed in a Pyrex tube (4 mm i.d., 2 cm length); luminol chemiluminescence with $\text{Fe}(\text{CN})_6^{3-}$ as rate modifier; determination of glucose in urine samples	120a, 120b, 120c
Packed	Glucose oxidase and peroxidase coimmobilized on diazotized polyaminostyrene beads packed in glass coils; continuous-flow system; fluorescence of the oxidation product of homovanillic acid (excitation: 315 nm, emission: 425 nm)	121
Packed	Glucose oxidase immobilized on controlled-pore glass and packed in a column located away from the point of detection; peroxidase immobilized on a glass disk located in the flow cell; determination of glucose in serum by luminol chemiluminescence; peroxidase acts as rate modifier	122
Packed	Miniaturized (microconduit) flow injection system; glucose oxidase immobilized on controlled-pore glass; luminol chemiluminescence (glucose determination) with $\text{Fe}(\text{CN})_6^{3-}$ as rate modifier	123
Open	Glucose oxidase immobilized on the wall of a nylon tubing; monitoring of glucose concentration during fermentation using a continuous-flow system; luminol chemiluminescence	124a, 124b, 124c

TABLE 4 (continued)
Selected Examples of Reactors Containing Immobilized Glucose Oxidase

I. Reactors located after sample introduction but before detection in continuous-flow manifolds

Luminescence detection

Reactor type	Comments	Ref.
Packed	Glucose oxidase immobilized with glutaraldehyde attachment to aminopropyl controlled-pore glass; luminol chemiluminescence with peroxidase in the carrier solution as rate modifier; determination of glucose in animal cell cultures	125

Image analysis

Reactor type	Comments	Ref.
Packed	Image analyzer system for multicomponent analysis; glucose oxidase and glucose-6-phosphate immobilized on a highly crosslinked polydextran support; enzyme preparations packed into a capillary tube; a section of capillary tube captured for image analysis; stopped flow used in conjunction with a charged coupled device and a video cassette recorder for spatial resolution of closely spaced responses	126

Post-column reactors for high-performance liquid chromatography

Reactor type	Comments	Ref.
Packed	Sequential immobilized enzyme reactors to hydrolyze -D-glucosides to -D-glucose (using -glucosidase) and then produce H ₂ O ₂ with glucose oxidase; luminol chemiluminescence with horseradish peroxidase as rate modifier	127

II. Miscellaneous reactor configurations

Comments	Ref.
Glucose oxidase immobilized on the inner wall of a nylon tube inserted into the observation cell of a commercial stopped-flow spectrophotometer	128
Cylindrical magnetic stirrer designed to hold glucose oxidase and peroxidase (immobilized on cellulose); a nylon cloth tube acts as barrier permitting the flow/ stopped-diffusion of substrate and products of the enzyme-catalyzed reactions	129
Integrated rotating bioreactor-ampereometric detection unit; bioreactor contains glucose oxidase immobilized on top of a rotating disk; rotation minimizes diffusional constraints and allows high rates of the catalyzed reaction with very small amounts of enzyme; ampereometric detection afforded by using a stationary Pt-ring electrode concentric to the rotating bioreactor; continuous-flow/stopped-flow/continuous-flow processing of sample and reagents	130a, 130b, 130c, 130d

TABLE 4 (continued)
Selected Examples of Reactors Containing Immobilized Glucose Oxidase

II. Miscellaneous reactor configurations

Comments	Ref.
Spectrophotometric cell comprising parallel bioreactors facing each other; the upper reactor is fixed and contains a film of immobilized glucose oxidase; the lower reactor rotates and contains a film of immobilized horseradish peroxidase; operating characteristics of the cell illustrated with the determination of glucose in serum samples utilizing Trinder's reaction system	131
Three different surface strategies based on sol-gel-derived glasses evaluated as sensing platforms to detect glucose by doping with glucose oxidase; the three strategies tested were based on: (1) physisorption, (2) microencapsulation, and (3) a sol-gel/glucose oxidase/sol-gel sandwich; the sandwich configuration was found to provide fast response and high enzyme loading; amperometric and photometric detection employed to determine glucose	132

pared by forming a carbon paste with graphite, Nujol as pasting liquid, and *n*-octadecylamine. The amine group was then reacted with glutaraldehyde and bovine serum albumin, and finally the enzyme (in a glutaraldehyde solution) was incorporated in the gelatinous membrane formed. This is another example in which the use of immobilized glucose oxidase is incidental but justified to demonstrate the potentials of an enzyme-reactor layer in the disk of a rotating ring-disk electrode configuration. Later on, Kamin and Wilson¹⁴² extended the studies to graphitic oxide (prepared by wet chemical oxidation or dry oxygen plasma ashing) and platinum surfaces. An interesting observation emanating from these studies is their conclusion that at rotation speeds equal or larger than 1600 rpm, the overall process operates under catalytic control. Contemporarily to these studies, Bourdillon et al.¹⁴³ covalently attached glucose oxidase to graphitic surfaces that were first chemically oxidized (nitric acid + dichromate treatment) with the help of electrochemical cycling and final enzyme attachment using carbodiimide activation.⁹⁰ Glucose has also been covalently immobilized on graphitic electrodes by a linking procedure involving a carbodiimide reagent.¹⁴⁴ The carbonaceous surface is elec-

trochemically pretreated in a 0.10 M KNO₃ solution (oxidation at +2.3 V vs. SCE) before attaching the enzyme.

Strategies used to design the glucose oxidase-reactor unit are numerous, and this appears as a point that has stimulated the imagination of those working with amperometric methods, and chemically modified electrodes in particular. Chi and Dong¹⁴⁵ modified a glassy carbon surface by electrochemically codepositing palladium and glucose oxidase, and covering the surface with a thin film of Nafion (perfluorinated ion-exchange membrane). The authors report that "there is no obvious interference from substances such as ascorbate and saccharides." Glucose oxidase has also been adsorbed on a modified electrode of palladium/gold sputtered on graphite.¹⁴⁶

Although recently the focus has been on amperometric monitoring (mainly of H₂O₂ production), some potentiometric reactor/detection units can be found in contributions of some years back. Liu et al.,¹⁴⁷ for instance, coentrapped glucose oxidase and catalase in a polyacrylamide gel layer around a platinum screen to provide a potentiometric unit in which the potential difference was found to be logarithmically related to glucose concentration.

A microhole-array electrode (bearing 1000 microholes of 7 μm diameter and 50 to 100 μm depth) was fabricated by immobilizing glucose oxidase on the surface of the platinized microhole array.¹⁴⁸ Immobilization was accomplished by immersion into a solution containing the enzyme and 1-cyclohexyl-3-(2-morpholinoethyl)carbodiimide metho-*p*-toluenesulfonate. A non-aqueous photopolymer (UV irradiation of partially hydrolyzed poly[methyl methacrylate] as binder, bisphenol A-bis[2-hydroxypropyl methacrylate] as monomer, and a ketone-benzophenone system as initiator) containing dispersed glucose oxidase was used to construct photolithographically patterned membranes for amperometric glucose determination.¹⁴⁹ These glucose electrodes can have an adjustable linear response range provided by deposition of membranes containing a surfactant (dodecyltrimethylammonium chloride) that is leached out by conditioning.

Bélanger et al.¹⁵⁰ incorporated platinum microparticles into a polypyrrole/glucose oxidase film grown potentiostatically (+0.65 V vs. SCE) from aqueous solutions containing pyrrole and the enzyme. The dispersed platinum particles were incorporated by immersion of the film in a hexachloroplatinate(IV) solution. The platinized electrode gave amperometric responses at +0.7 V vs. SCE that were 40% higher than those obtained in the absence of platinum microparticles.

A simple strip-type electrode prepared from platinized Vulcan XC-72 carbon particles by using silk screen printing techniques was described by Cardosi and Birch.¹⁵¹ Glucose oxidase was covalently attached to the surface of the carbon particles by a carbodiimide-based bonding. Thick-film and laser micromachining procedures have been used to electrochemically localize glucose oxidase within the pores of 15- μm disks via codepositing with rhodium or platinum.¹⁵² The approach is considered potentially use-

ful in the production of glucose oxidase-based diagnostic strips.

Gough et al.^{153a,153b} described a reactor/sensor unit in which oxygen diffuses from two directions (a hydrophobic membrane surrounding a cylindrical oxygen sensor and the enzyme-containing gel), whereas the analyte (glucose) diffuses only through the enzyme-containing membrane located at the tip of the unit. The sensing element measures the excess oxygen that is not consumed as a result of the glucose oxidase-catalyzed reaction. The glucose oxidase is immobilized within a gel made with denatured bovine Achilles tendon collagen crosslinked with glutaraldehyde. The configuration is an improvement over previous designs based on the same sensing strategy. Some theoretical considerations about the performance of cylindrical amperometric reactor/detector units employing soluble redox mediators can be found in the literature.¹⁵⁴

Glucose-sensitive field-effect transistor sensors have been prepared by crosslinking glucose oxidase with bovine serum albumin in an atmosphere saturated with glutaraldehyde vapor.¹⁵⁵ The crosslinked enzyme was located on top of the gate area and covered with a Nafion membrane deposited by a spin-coating procedure. Mizutani et al.¹⁵⁶ also covered an amperometric sensing surface with a Nafion membrane utilizing a layer of lipid-modified glucose oxidase. A glassy carbon surface was first dipped into a benzene solution of the modified enzyme and dried. This was followed by dipping into a Nafion solution and drying again. The electrode was used for at least 6 weeks, exhibited rather rapid response, and was applied to the determination of glucose in fruit juices (orange and apple).

A composite barrier made of a diamond-like carbon-coated microporous polycarbonate membrane, impregnated with a crosslinking glucose oxidase/bovine serum albumin/glutaraldehyde mixture, was used to cover a commercial oxygen electrode

assembly.¹⁵⁷ The membrane acts as an enzyme reactor, protects the electrode, and permits the determination of glucose in whole blood.

The so-called biosensors based on immobilized glucose oxidase are obviously numerous. Besides the examples already mentioned in this review and those included in Table 4, glucose oxidase has been, for instance, incorporated into polypyrrole films electrically produced on glassy carbon or platinum electrodes,¹⁵⁸ poly(amphiphilic pyrrole) films,¹⁵⁹ and poly(*N*-methylpyrrole) electrochemically deposited on gold surfaces;¹⁶⁰ immobilized in poly(*o*-phenylenediamine) films by potentiometric electropolymerization on platinum surfaces,^{161a,161b} entrapped into a lipid matrix,¹⁶² adsorbed on platinized carbon paper¹⁶³ and platinum,¹⁶⁴ electrodeposited on platinum black together with bovine serum albumin, and finally crosslinked with glutaraldehyde.¹⁶⁵ Centonze et al.¹⁶⁶ discussed the influence of ascorbic acid on the response of a glucose sensor with the enzyme immobilized on electropolymerized poly(*o*-phenylenediamine) or overoxidized poly(pyrrole) films on a platinum electrode. They concluded that the decrease in sensor response cannot be attributed to depletion of H₂O₂ via the homogeneous reaction with ascorbate. The culprit seems rather to be the electrode surface fouling by electrooxidation products of ascorbic acid. The overoxidized poly(pyrrole) film completely eliminates the interference of ascorbate.

A great deal of interest in the development of electron shuttling to facilitate the electron transfer between the active center of the enzyme and an electrode can be observed in the last two decades. The majority of these efforts involve the use of chemical species used as redox mediators. Figure 3 schematically shows how redox mediators can facilitate the electrical communication between the enzyme active site and the electrode surface.

Table 5 provides a tabulation of redox mediators that have been proposed and used in conjunction with glucose oxidase.

Direct communication can be achieved, with the enzyme practically becoming an intrinsic part of the electrode. The admixing with carbon paste already cited⁹⁶ is an example, and the composite formulation proposed by Céspedes et al.^{192a,192b} represents an effort in the same direction. The composite contained graphite, palladium-gold in an epoxy resin, and glucose oxidase. The matrix was used to detect the electrocatalytic oxidation of H₂O₂ at the gold-palladium conductor, and simple polishing using a 3- μ m alumina paper wetted with distilled water generated fresh surfaces for detection purposes. These efforts were preceded by a bioreactor/detector design in which the electrode was a graphite-epoxy composite and the enzyme reactor part was a nylon 6,6 membrane with glucose oxidase immobilized after activation with dimethyl sulfate.^{192b} More recently, Sakslund et al.¹⁹³ described the preparation of a glucose biosensor by electrochemically codepositing palladium and glucose oxidase on a glassy carbon electrode.

Nolte et al.^{194a,194b} reported on a biosensor approach involving glucose oxidase, which they claim results in direct communication between the enzyme and polypyrrole as a conducting polymer synthesized inside the pores (tubules) of a filtration membrane. More recently, however, Kuwabata and Martin¹⁹⁵ studied the mechanism of the amperometric response to glucose of this type of sensor and concluded that the current signal results from direct electrochemical oxidation of glucose at the platinum film coated onto one face of the membrane. This finding opens an interesting question with respect to the role of the many redox mediators proposed in the literature. Moore et al.¹⁹⁶ "turned the table" in the tactical approach of using mediators and presented the determination of some pharmaceuticals (e.g., ac-

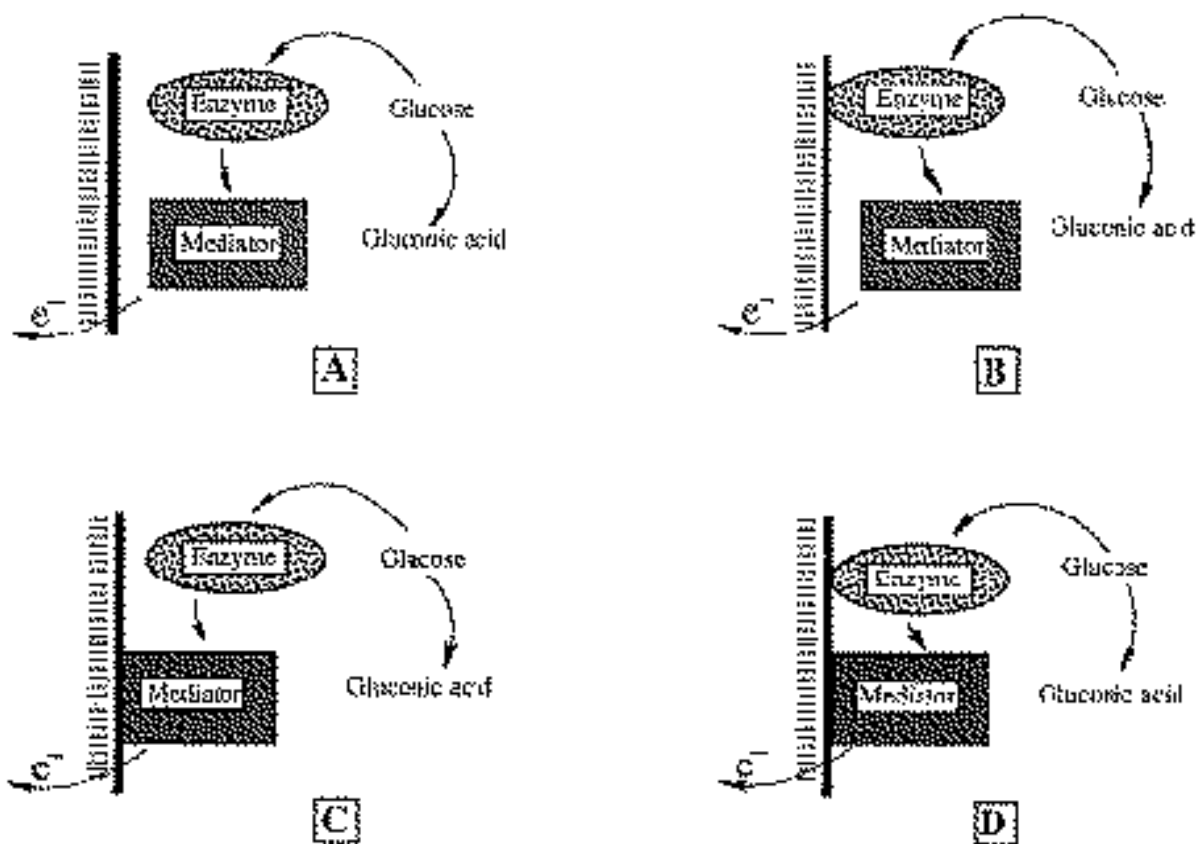

FIGURE 3. Possible ways of organizing electron transport from the enzyme active site to the electrode. (A) Mediator and enzyme in solution. (B) Enzyme immobilized and mediator in solution. (C) Mediator immobilized and enzyme in solution. (D) Mediator and enzyme both immobilized on the surface of the electrode.

etaminophen, norepinephrine, and chlorpromazine) in which the analyte plays the role of redox mediator. The amplification scheme allows limits of detection in the 0.1 to 0.3 μM range.

Of special interest in the development of electrodes with a direct electrical communication between the redox enzyme and the electrode itself are efforts centered on chemical modification of the enzyme. Degani and Heller,^{197a-197c} for instance, have attached inside the enzyme different chemical species acting as electron relays. Direct communication entails electron transfer from the enzyme's redox centers to relays that are closer to the periphery of the enzyme; these electrons are then transferred at practical rates

to the electrode surface. Therefore, direct electrical communication is established between the FAD/FADH₂ centers of the enzyme and gold, platinum, or carbon-conducting surfaces. Examples of relays include: (1) amides formed between enzyme amines and ferrocenylacetic acid, ferrocenecarboxylic acid, or ruthenium pentaamine complexes of isonicotinic acid; (2) azo compounds made by reacting the diazonium salt of 4-aminopyridine with the enzyme, followed by complexing the enzyme-bound pyridine with ruthenium pentaamine, and (3) ruthenium pentaamine chemically bound to the enzyme. 3-Carboxymethylpyrrole has been attached covalently to lysyl residues of glucose oxi-

TABLE 5
Typical Redox Mediators Used in Conjunction with Glucose Oxidase in Bioreactor/Detection Systems

Mediator	Comments	Ref.
Hexacyanoferrate(III), <i>p</i> -benzoquinone, 2,6-dichlorophenolindophenol, pyocyanine, thionine, or methylene blue	Slightly recessed Pt electrode coated with a thin layer of enzyme solution; enzyme solution separated from test solution containing the mediator by a cellophane membrane	167
Organic metal complexes of <i>N</i> -methylphenazinium or <i>N</i> -methylacridinium and the anion radical tetracyano- <i>p</i> -quinodimethane.	Organic metal complexes pressed into conducting (metallic) disks glued to a glass tube; solution containing enzymes (glucose oxidase, cytochrome b, and peroxidase) entrapped on the surface of the electrode by using a dialysis membrane	168
7,7,8,8-Tetracyano- <i>p</i> -quinodimethane, quinone, pyocyanine dichlorophenolindophenol, dextran-dopamine	Glucose oxidase in solution entrapped by a dialysis membrane as a layer adjacent to a glass-carbon electrode coated with mediator	169
Ferrocene and derivatives	Mediator deposited onto the surface of the electrode and air dried; enzyme covalently attached (carbodiimide) to the surface of the electrode and covered with a polycarbonate membrane	170
Benzoquinones	Carbon paste electrodes modified by direct admixing of glucose oxidase and modifier	171a, 171b, 171c, 171d
	Glucose oxidase and mediator entrapped (glutaraldehyde crosslinking) on the surface of a graphite foil disk	172
	Glucose oxidase immobilized (adsorption) on a carbon electrode by covering its surface with a solution of the enzyme and allowing solvent to evaporate; mediator in solution	173
	Crosslinked and noncrosslinked poly("ether-aminequinone") used as electron-transfer relays in carbon paste electrodes	174
Ruthenium compounds, octacyanotungstate(VI) and -molybdate(VI)	<i>p</i> -Benzoquinone and ferrocenemonocarboxylic acid; polyaniline-coated platinum electrode	175
	Mediator and enzyme used in solution; catalytic currents observed at carbon electrodes.	176, 177
Viologens	Several water-soluble viologens and glucose oxidase incorporated into carbon paste formulations	178
Cobalt phthalocyanine	Enzyme and mediator immobilized as a colloidal graphite dispersion matrix applied to a glassy carbon disc electrode; very good storage stability	179
<i>N</i> -Methylphenazin-5-ium	Mediator adsorbed on graphite; enzyme covalently attached (via activation with cyanuric chloride) to oxidized graphite surfaces after selective reduction by LiAlH ₄	180a, 180b

TABLE 5 (continued)
Typical Redox Mediators used in Conjunction with Glucose Oxidase in Bioreactor/Detection Systems

Mediator	Comments	Ref.
Tetrathiatetracene (TTT), tetrathiafulvalene (TTF), and 1, 2-dimethyltetraselenafulvane (DMTSF)	TTT and TTF in solution, DMTSF adsorbed together with glucose oxidase on a graphite electrode	181
Tetrathiafulvalene	Ink-jet printing on poly(vinylchloride) for deposit of mediator and glucose oxidase	182
	Mediator in solution; microelectrochemical enzyme transistor prepared by connecting two carbon band electrodes; glucose oxidase immobilized on an anodically grown film of poly(aniline)	183
Osmium-bipyridyl complexes	Mediator incorporated as a crosslinkable poly(vinylpyridine) complex; the mediator was used in a reactor/sensor system in which the measured response corresponds to reaction of all substrate (equilibrium-based measurement)	184a, 184b, 184c, 184d
	Osmium-containing redox polymer with bipyridyl, poly-(4-vinylpyridine) and chloride; enzyme and mediator codeposited on the surface of a Pt electrode with glutaraldehyde; the resulting surface covered with an electropolymerized layer of pyrrole also containing glucose oxidase	185
	Enzyme and redox polymer codeposited by embedding vitreous carbon rods in a Teflon shroud using a low-viscosity epoxy resin	186
	Glucose oxidase immobilized in a hydrogel formed by crosslinking poly(1-vinylimidazole) complexed with Os(4,4 -dimethylbipyridyl) ₂ Cl with poly(ethylene glycol) diglycidyl ether	187
7-Dimethylamino-1,2-benzophenoxazinium salt (Meldola Blue)	Mediator and glucose oxidase admixed in a carbon paste electrode	188
tetrathiafulvane-7,7,8,8-tetracyanoquinodimethane	Mediator and glucose oxidase incorporated together in carbon paste electrodes	189
4,4 -Dihydroxybiphenyl	Mediator tested in solution, adsorbed on glassy carbon, and also electropolymerized on glassy carbon	190
Hydroquinone	Glucose oxidase and hydroquinone coimmobilized in a carbon paste electrode; surface activation shown to improve electrochemical reversibility and analytical performance; activation by a linearly varying potential between 0.6 and 2 V at 50 mV/s for a given time in unstirred solution of 0.50 M NaOH or NaHCO ₃	191

dase and copolymerized with unmodified pyrrole to produce films of high conductivity and enzyme activity.¹⁹⁸ Of singular interest is a recently introduced sensor in which the glucose-sensing layer was made by crosslinking a genetically engineered glucose oxidase (Chiron Corp., Emeryville, CA) with a polymer based on poly(vinylimidazole) and made by complexing part of the imidazole moieties to $[\text{Os}(\text{bipyridine})_2\text{Cl}]^{+2+}$.¹⁹⁹ The enzyme “wired” layer is part of a subcutaneously implanted glucose sensor operating as a one-point in vivo calibration unit.

It seems appropriate to close this section of the review with the mention that amperometric detection has been implemented into worldwide commercially available pen-size digital glucose meters. These devices follow the original design pioneered by Matthews et al.²⁰⁰ and comprise a disposable strip in which the glucose oxidase reactor and electrode system are located; the potentiostat/amplifier system is contained in the pen body in which a liquid crystal display and an on/off switch are also located. The disposable strip is inserted into one of the ends of the pen body (Figure 4).

B. Optically Based Detection in Reactor/Detector Units

The type of units covered here are also commonly known as *optoelectrodes* or *optical biosensors*. A distinctive feature of these devices is the use of fiber optics that shuttle photons from a source of radiant energy to the enzyme reactor and/or from the enzyme reactor to the detection devices (commonly a photomultiplier tube, photocell, or photodiode). Consequently, these devices may measure absorbance, fluorescence, or chemiluminescence. Besides the fact that photons travel faster than electrons, these optically based devices avoid or minimize problems such as electrical interferences, electrical connections, junction potentials, and reference/auxiliary electrode pairs. The interested reader would benefit by consulting available monographs^{201a–201d} and reviews.^{202a–202e} In consideration of the chemistry of the main enzyme-catalyzed reaction for the determination of glucose ($\text{glucose} + \text{O}_2 + \text{H}_2\text{O} = \text{gluconic acid} + \text{H}_2\text{O}_2$), optical sensing, in contrast to electrochemical sensing, has paid little attention to the H_2O_2 , and has rather focused on the O_2 consumption or pH decrease. Table 6 presents examples of these

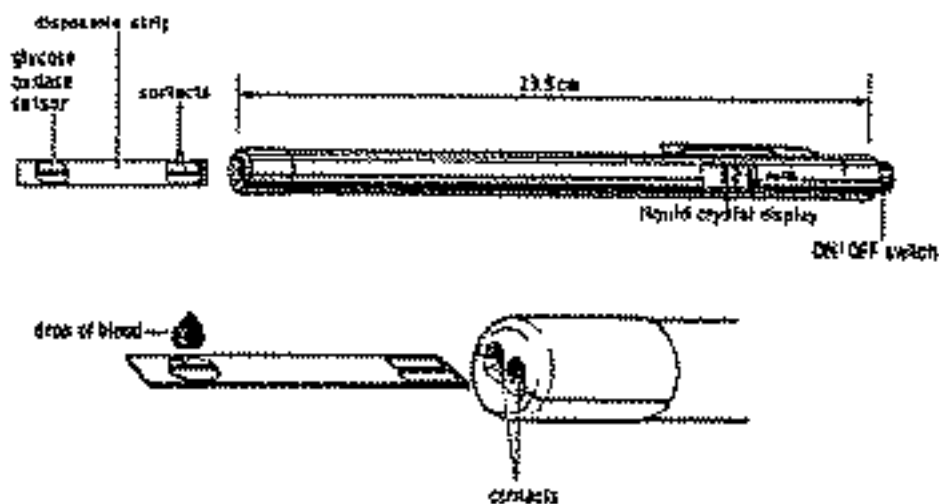

FIGURE 4. Pen-size glucose meter. (From Reference 200. With permission.)

TABLE 6
Typical Examples of Reactor/Detection Units of the “Optrode” Type Based on O₂-Quenching of Luminescence or pH Change

	Ref
Oxygen-quenching-based devices	
Quenching the fluorescence of bis(2-ethylhexyl) phthalate; first glucose oxidase-based “optrode;” Complex signal response controlled by bidirectional mass transfer across the membrane holding the enzyme layer in place	204a, 204b
Quenching the fluorescence of the dye decacyclene dissolved in a very thin silicone-based membrane located beneath the enzyme layer; dynamic range: 1 to 20 mM; response stable for at least 5 months	205
Glucose oxidase immobilized on the surface of the oxygen “optrode” by adsorption onto carbon black and crosslinking with glutaraldehyde; carbon black used as an optical “insulator” to protect the oxygen probe from ambient light and sample fluorescence interference	206
Quenching the fluorescence of tris(1,10-phenanthroline)ruthenium(II) cation; complex adsorbed onto silica gel incorporated in a silicone matrix possessing high oxygen permeability, and placed at the tip of the optical fiber of the oxygen sensor that also contained the enzyme	207
Hydrogen ion (pH)-sensing devices	
Bromocresol Green indicator; monitoring of absorbance change; optoelectronic light-emitting diodes used	208
Fluorescence indicator (1-hydroxypyrene-3,6,8-trisulfonate); glucose detected in the 0.10 to 2 mM range; Slow response (8 to 12 min for 90% signal) that depends on the buffer capacity of the medium	209

approaches. An exception seems to be the work of Trettnak and Wolfbeis²⁰³ in which the intrinsic fluorescence of glucose oxidase is utilized as the basis for measurement of glucose concentration. Excitation is at 450 nm and measured emission at 550 nm. A solution of glucose oxidase or a gel-entrapped (bovine serum albumin and glutaraldehyde) enzyme was compartmentalized by a dialysis membrane at the end of the fiber optic conduit. Both approaches provided comparable responses to glucose concentration.

C. Thermal Detection

During the 1970s thermal detection of reaction enthalpy in glucose oxidase-catalyzed oxidation of glucose received consid-

erable attention and commercial units entered the market. A unique property of enthalpimetric monitoring is that there are very few chemical processes that do not involve at least 5 (kcal.mol⁻¹)^{87a} and this is of particular analytical interest. Experimental aspects and calculations related to glucose oxidase thermal probes can be found in the literature²¹⁰ as well as in reviews pertinent to the topic.^{211a,211b}

The detection unit (mostly thermistors) is located in very close proximity to the site of reaction (reactor), because the heat change is most pronounced in the vicinity of the enzyme active site environment. According to Mosbach and Danielson²¹² there are two ways of accomplishing this: (1) direct immobilization of the enzyme onto the thermistor and (2) encirclement of the thermistor

by a coil of tubing packed with matrix-bound enzyme.

One of the first applications of thermal monitoring for glucose determination was introduced in 1973 by Johansson.²¹³ Subsequent examples of thermometric monitoring for glucose determination using immobilized glucose oxidase are summarized in Table 7. Muehlbauer et al.²¹⁴ have mathematically modeled the response of a calorimetric glucose sensor with the purpose of describing the energy and mass balance. The validity of the model was ascertained with experimental data obtained with a prototype sensor consisting of a thermopile to which a membrane containing immobilized glucose oxidase and catalase was attached.

IX. THE USE OF GLUCOSE OXIDASE IN ENZYME IMMUNOASSAYS

Immunoassays designate a variety of determinative procedures that are widely used in biomedical research and in clinical laboratories.²²² Immunology, protein chemistry, and enzymology have greatly benefited from

applications involving enzyme immunoassays. Early developments centered on what has become to be known as *radioimmunoassays*; since then, the literature has recorded an exponential growth in the development of isotopic as well as nonisotopic immunoassays. Basically, immunoassays rely on a reversible antigen-antibody reaction that can be represented as follows

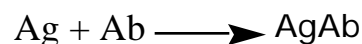

where Ag is free antigen, Ab free antibody sites, and AgAb the antigen-antibody complex. Antibodies are bifunctional molecules that bind antigens at specific sites and serve as linkers of the specific antigen to immune system cells. Enzymes are used as labeling agents to aid in the detection; examples of enzyme immunoassays are presented in Table 8, which adopts the classification of Wisdom.²²³

Although glucose oxidase fulfills the conditions of compatibility for use as a label in immunoassays,^{225a,b} including the desirable property of almost nil background in mammalian tissue,^{225b} it has been used less frequently than other enzymes such as per-

TABLE 7
Examples of Reactor/Detector Units Employing Immobilized Glucose Oxidase and Thermometric Detection

	Ref.
Thermistor (sensor) in contact with the enzyme that is gel immobilized and fills a microcolumn in contact with the detection unit	215
Capillaries used for heat transfer from the enzyme reactor part to the thermistor (no direct contact); time needed per determination: 20 min	216
Use of a tubular reactor; time per determination: 5 min.	217
Small glass-encapsulated thermistor containing immobilized catalase and located at the end of a packed column containing immobilized glucose oxidase	218
Divided-flow "enzyme thermistor" composed of two similar microcolumns; one of the columns contains the immobilized enzyme and the other is filled with glass beads	219a, 219b, 219c
Thermistor coated with a membrane containing the glucose oxidase and prepared by glutaraldehyde crosslinking of serum albumin	220
Array of <i>p</i> -type semiconducting silicon-aluminum strips integrated onto a thin silicone membrane; glucose oxidase and catalase directly immobilized on the back side of the thermopile	221

TABLE 8
Operational Classification of Enzyme Immunoassays, EIA

Diagrammatic Illustration	Comments
	<p>Homogeneous EIA^a</p> <p>The covalently enzyme-labeled antigen competes with the unlabeled antigen in the sample for a limited concentration of antibody; it has been suggested that the inhibition of enzyme activity is caused by the complexation of antibody molecules to haptens located sufficiently near the active site of the enzyme;²²⁴ the substrate is then sterically excluded</p>
	<p>Hetereneous EIA^b</p> <p><i>Competitive enzyme immunoassay for antigen.</i> Adheres to the general principles of saturation analysis; The labeled antigen competes with unlabeled antigen from the sample for a limited amount of solid-phase-immobilized antibody; after brief incubation, the antibody-bound Ag-E is separated from the unbound Ag-E; the enzyme activity associated with the solid phase is inversely related to concentration of the analyte</p>
	<p><i>Competitive enzyme immunoassay for antibody.</i> Labeled and unlabeled antibody compete for immobilized antigen; the amount of antibody is determined by measuring the enzyme activity in the free or bound fractions, after centrifugation</p>
	<p><i>Immunoenzymometric assay.</i> Excess of labeled antibody reacts with antigen; then an excess of immobilized antigen is added; after centrifugation, the activity associated with the soluble antigen fraction is measured</p>
	<p><i>Sandwich enzyme immunoassay.</i> Requires antigens with multiple binding sites (epitodes); the antigen being determined is held between two different antibodies; excess of immobilized antibody is added to the sample, and after incubation, followed by washing, the enzyme-labeled antibody is added; the enzyme activity associated with the immobilized antibody provides a direct measurement of the amount of antigen present in the sample</p>

TABLE 8 (continued)
Operational Classification of Enzyme Immunoassays, EIA

Diagrammatic Illustration	Comments
	<p>Heterogeneous EIA^b</p> <p><i>Enzyme immunoassay for antibody.</i> Very similar to the sandwich immunoassay; the antigen is immobilized, however; provides direct measurement of the amount of specific antibody present</p>

- ^a This approach does not require separation of free and bound antigen.
- ^b More sensitive and less prone to interferences. A separation step is required.

oxidase, alkaline phosphatase, and β -galactosidase.²²⁶ Examples of immunoassays in which glucose oxidase is used as label are tabulated in Table 9.

X. THE DETERMINATION OF GLUCOSE OXIDASE ACTIVITY

A review on the use of glucose oxidase as an analytical reagent cannot be closed without mentioning how to ascertain the activity of the reagent. The catalytic activity of an enzyme, as mentioned earlier in this review, is proportional to the number of operating active sites at the time of its measurement. Although related to the concentration of the protein content in the medium, the activity may be different for different preparations of the same enzyme, and the analytical concentration becomes useless in describing enzyme activity. Moreover, the activity of a given enzyme preparation may change with time. As such, the “standardization” of enzyme preparations must be based on activity rather than concentration. A very common procedure for assessment

of glucose oxidase activity is to determine the reaction velocity in the presence of glucose as the substrate. The increase of absorbance at 460 nm results from the oxidation of *o*-dianisidine through a peroxide-coupled system. One unit corresponds to the concentration of enzyme that causes the oxidation of 1 μ mol of *o*-dianisidine per minute at 25°C and pH 6.00 under the conditions specified for the test.²⁴⁹ Of course, other dyes and different detection approaches can be used.

EPILOGUE

As this review goes to press and after its publication, the number of papers in which glucose oxidase (particularly in immobilized form) is used to demonstrate new avenues for biosensing, and eventually for glucose determination, will continue to increase. The overall framework adopted in this review, however, is expected to remain as a fairly accurate representation of applications of the ubiquitous enzyme glucose oxidase as an analytical reagent.

TABLE 9
Examples of Immunoassays Utilizing Glucose Oxidase Labeling

Type of enzyme immunoassay	Comments	Ref.
Competitive	Determination of antigens; the main reagent is a pure specific antibody covalently linked to glucose oxidase; application to the determination of human IgG; enzyme activity determined spectrophotometrically with α -dianisidine	227
Immunoenzymometric	Noncompetitive method for the determination of human α -fetoprotein in serum	228
Sandwich	Noncompetitive sandwich method for rat and human α -fetoprotein; the antigen (analyte) is reacted with antibody-coated cellulose; then the antibody (labeled with glucose oxidase) is incubated with the antigen bound to the solid phase; finally the enzymatic activity of the immunosorbent is measured	229
Competitive	Thermometric enzyme-immunosorbent determination; the antibody is immobilized on Sepharose CL 4B, packed in an insulated glass column with the flow upward, and the thermistor immersed in the top of the bed	230
Homogeneous	Prosthetic group label immunoassay, competitive binding; determination of haptens in solution	231a, 231b
Competitive	Determination of human follicle-stimulating hormone.	232
Homogeneous	Antibody-induced conformational restriction enzyme immunoassay; under acid denaturing conditions, holo-glucose oxidase labeled with 2,4-dinitrophenyl groups dissociated into FAD and 2,4-dinitrophenyl-labeled apoglucose oxidase; the enzyme activity restored by incubating with FAD around pH 7.0	233
Sandwich	Determination of choriogonadotropin; ultrasound used to enhance mass transfer and circumvent the slow binding of macromolecular antigen and conjugate to the immobilized phase; glucose oxidase immobilized on a cellulose support and horseradish peroxidase used in the liquid phase to complete the immune sandwich	234
Competitive	Determination of α -fetoprotein, insulin, and 17- β -hydroxyprogesterone; free and bound fractions present after the immune reaction separated by an immobilized antibody or second antibody; measurement based on luminol chemiluminescence by incubation with glucose	235
Competitive	Determination of thyroxin; determination based on the chemiluminescence of bis(2,4,6-trichlorophenyl) oxalate in presence of 8-anilino-1-naphthalene-sulfonic acid	236
Sandwich	Determination of immunoglobulin G; continuous-flow system with electrochemical detection of H_2O_2 in a thin-layer amperometric cell	237
Competitive	Ferrocene used instead of O_2 in the glucose oxidase-catalyzed oxidation of glucose; amperometric detection of reduced ferrocene; a magnetic working electrode used to separate bound and free analyte and to monitor the ferrocene; determination of human chorionic gonadotropin	238

TABLE 9 (continued)
Examples of Immunoassays Utilizing Glucose Oxidase Labeling

Type of enzyme immunoassay	Comments	Ref.
Sandwich	Determination of human chorionic gonadotropin utilizing a capture antibody covalently attached to a carbon electrode; amperometric measurement; the electrode surface acts as support for the sandwich immunoassay determination	239
Homogeneous	Thyroxine has been modified with a ferrocene derivative to produce an immunologically reactive conjugate; the conjugate, acting as an electron transfer mediator, has been used as a tracer in an immunoassay to determine total thyroxine concentration in serum; amperometric monitoring was used after the addition of glucose oxidase and glucose on completion of antibody/antigen binding	240
Competitive	Determination of β -hydroxyprogesterone in dried blood spotted on filter paper; fluorescence and chemiluminescence measurements	241
Sandwich	Determination of IgG by electrocatalytic detection of enzyme-labeled antibody; benzoquinone used to determine the immobilized glucose oxidase activity in presence of glucose	242
Competitive	Determination of human IgG; antibody covalently attached to the polymer Trisacryl GF2000 and packed into a microreactor; amperometric measurement of H_2O_2	243
Homogeneous	Determination of human chorionic gonadotropin. glucose oxidase and the anti-human chorionic gonadotropin monoclonal antibody coimmobilized on a glassy carbon electrode; soaking in 50% ethylene glycol regenerates the electrode; dimethyl-aminomethylferrocene used as electron transfer mediator	244
Sandwich	Detection of <i>Salmonella typhimurium</i> ; adsorption of antibody on Tygon tubing and covalent binding on polyethylene tubing; flow injection system with immuno-reactor located before amperometric detector; detection of H_2O_2	245
Competitive	Determination of human IgG. Electro polymerized polytyramine-modified Pt electrode used to detect H_2O_2 ; the IgG conjugates were labeled with glucose oxidase	246
Competitive	Determination of anti- <i>salmonella</i> based on the color formed between poly(vinyl alcohol) (absorbance at 510 nm) or starch (absorbance at 660 nm) and the iodine produced from iodide in the presence of H_2O_2 from the glucose oxidase-catalyzed reaction	247
Competitive	The <i>p</i> -nitrophenyl ester method assessed in a testosterone determination; glucose oxidase and also alkaline phosphatase used as enzyme labels; the tetramethylbenzidine-horseradish peroxidase system used to measure glucose oxidase activity	248

ACKNOWLEDGMENTS

Support from the Office of Research of the College of Arts and Sciences of Oklahoma State University made this review possible. A fellowship from the Consejo Nacional de Investigaciones Científicas y Técnicas (CONICET) of Argentina is gratefully acknowledged by one of the authors (JR).

REFERENCES

1. Stetter, H. *Enzymatische Analyse*; Verlag-Chemie: Weinheim, New York, 1951.
2. Osann, G. *Poggendorff's Ann.* **1846**, 67, 372–374.
3. Mottola, H.A. *Analyst.* **1987**, 112, 719–727.
4. Berry, D.R.; Paterson, A. Enzymes in the food industry, in *Enzyme Chemistry, Impact and Applications*, 2nd ed.; C. J. Suckling, Ed.; Chapman and Hall: London, 1990; p. 319.
- 5a. Nakane, P.K.; Watanabe, T. *J. Histochem. Cytochem.* **1984**, 32, 894–898.
- 5b. Muzykantov, V.R.; Sakharov, D.V.; Sinitsyn, V.V.; Domogatsky, S.P.; Goncharov, N.V.; Danilov, S.M., *Anal. Biochem.* **1988**, 169, 383–389.
6. Mottola, H.A. *Anal. Chim. Acta.* **1983**, 145, 27–39.
7. Mottola, H.A.; Mark, Jr., H.B. Kinetic methods, in *Instrumental Analysis*, 2nd ed.; G. D. Christian and J. E. O'Reilly, Eds., Allyn and Bacon: Boston, 1978, Chapter 18.
8. Laidler, K.J. *Chemical Kinetics*, 3rd ed.; Harper & Row: New York, 1987, p. 14.
9. Jenks, W.P. in *Advances in Enzymology and Related Areas of Molecular Biology*, Vol. 43; A. Meister, Ed.; Wiley: New York, 1975, p. 222.
10. Fersht, A. *Enzyme Structure and Mechanism*; Freeman: San Francisco, 1977, p. 3.
- 11a. Fisher, E. *Chem. Ber.* **1894**, 27, 2985–2993.
- 11b. Pfeiffer, J. *Enzymes, the Physics and Chemistry of Life*; Simon and Schuster: New York, 1954, p. 171.
12. Koshland, D.E. *Proc. Natl. Acad. Sci.* **1958**, 44, 98–104.
13. Kachmar, J.F.; Moss, D.W. in *Fundamentals of Clinical Chemistry*; N. Tietz, Ed.; W.B. Saunders: Philadelphia, 1976, Chapter 12.
14. Müller, D. *Biochem. Z.* **1928**, 199, 136–170.
15. Bernhauer, K. *Z. Physiol. Chem.* **1928**, 177, 86–106.
16. Nord, F.F.; Engel, W. *Biochem. Z.* **1938**, 296, 153–170.
- 17a. Franke, W.; Lorenz, F. *Liebigs Ann.* **1937**, 532, 1–28.
- 17b. Franke, W.; Deffner, M. *Liebigs Ann.* **1939**, 541, 117–150.
18. Müller, D. *Enzymologia.* **1941**, 10, 40–47.
19. Ogura, T. *Acta Phytochim.* **1939**, 11, 127–144.
20. Franke, W. *Liebigs Ann.* **1944**, 555, 111–132.
21. Keilin, D.; Hartree, E.F. *Biochem. J.* **1948**, 42, 221–229.
- 22a. Keilin, D.; Hartree, E.F. *Biochem. J.* **1948**, 42, 230–238.
- 22b. Keilin, D.; Hartree, E.F. *Biochem. J.* **1952**, 50, 331–341.
23. Kusai, K.; Sekuzu, I.; Hagihara, B.; Okununi, K.; Yamauchi, S.; Nakai, N. *Biophys. Acta.* **1960**, 40, 555–557.
24. Pazur, J.H.; Kleppe, K.; Ball, E.M. *Arch. Biochem. Biophys.* **1963**, 103, 515–516.
25. Swoboda, B.E.P.; Massey, V. *J. Biol. Chem.* **1964**, 240, 2209–2215.
26. Chi, Q.; Zhang, J.; Dong, S.; Wang, E. *J. Chem. Soc., Faraday Trans.* **1994**, 90, 2057–2060.
27. Frederick, K.R.; Tung, J.; Emerik, R.S.; Masiarz, F.R.; Chamberlain, S.H.; Vasavada, A.; Rosenberg, S.; Chakraborty, S.; Schopfer, L.M.; Massey, V. *J. Biol. Chem.* **1990**, 265, 3793–3802.
28. Swoboda, B.E.P. *Biophys. Acta.* **1969**, 175, 365–379; 380–387.
29. Ehrenberg, A.; Hemmerich, P. in *Biological Oxidations*; T. P. Singer, Ed.; Wiley: New York, 1968, p. 239.

30. Dixon, M. *Biochim. Biophys. Acta.* **1971**, 226, 269–284.
31. Gibson, Q.H.; Swoboda, B.E.P.; Massey, V. *J. Biol. Chem.* **1964**, 239, 3927–3934.
32. Nakamura, T.; Ogura, Y. *J. Biochem.* **1962**, 52, 214–220.
- 33a. Nakamura, T.; Ogura, Y. *J. Biochem.* **1967**, 63, 308–316.
- 33b. Bright, H.; Appleby, M. *J. Biol. Chem.* **1969**, 244, 3625–3634.
- 33c. Duke, F.; Weibel, M.; Page, D.; Bulgrin, V.; Luthy, J. *J. Am. Chem. Soc.* **1969**, 91, 3904–3909.
- 33d. Weibel, M.; Bright, H. *J. Biol. Chem.* **1971**, 246, 2734–2744.
- 33e. Weibel, M.; Bright, H. *Biochem. J.* **1971**, 124, 801–807.
- 33f. Castner, J.F.; Wingard, Jr., L.B. *Biochemistry.* **1984**, 23, 2203–2210.
34. Wolff, Ch.-M.; Mottola, H.A. *Anal. Chem.* **1978**, 50, 94–98.
35. Malcome-Lawes, D.J.; Wong, K.H.; Smith, B.V. *J. Autom. Chem.* **1992**, 14, 73–78.
36. Keston, A.S. Abstracts, 129th National Meeting of the American Chemical Society, Dallas, TX, April 1956, pp 31C and 32C, Abstract No. 76. (Details on solutions and filter paper strip preparation are given in the abstract.)
37. Marks, V. *Clin. Chim. Acta* **1959**, 4, 395–400.
38. Dobrick, L.A. *J. Biol. Chem.* **1958**, 231, 403–409.
39. Salomon, L.L.; Johnson, J.E. *Anal. Chem.* **1959**, 31, 453–456.
40. Morley, G.; Dawson, A.; Marks, V. *Proc. Assoc. Clin. Biochem.* **1968**, 5, 42–57.
- 41a. Werner, W.; Rey, H.-G.; Wielinger, H. *Fresenius' Z. Anal. Chem.* **1970**, 252, 224–228.
- 41b. Kahle, K.; Weiss, L.; Klarwein, M.; Wieland, O. *Fresenius' Z. Anal. Chem.* **1970**, 252, 228–231.
42. Trinder, P. *J. Clin. Pathol.* **1969**, 22, 158–161.
43. Kabasakalian, P.; Kalliney, S.; Wescott, A. *Clin. Chem.* **1974**, 20, 606–607.
44. Clapp, P.A.; Evans, D.F. *Anal. Chim. Acta* **1991**, 243, 217–220.
45. Beach, E.F.; Turner, J.J. *Clin. Chem.* **1958**, 4, 462–475.
46. Nelson, N. *J. Biol. Chem.* **1944**, 153, 375–380.
47. Folin, O.; Malmros, H. *J. Biol. Chem.* **1929**, 83, 115–127.
48. Kingsley, G.R.; Getchell, G. *Clin. Chem.* **1960**, 6, 466–484.
49. Malmstadt, H.V.; Hicks, G.P. *Anal. Chem.* **1960**, 32, 394–398.
- 50a. Malmstadt, H.V.; Pardue, H.L. *Anal. Chem.* **1961**, 33, 1040–1047.
- 50b. Malmstadt, H.V.; Pardue, H.L. *Clin. Chem.* **1962**, 8, 606–615.
51. Mottola, H.A. *Kinetic Aspects of Analytical Chemistry*; Wiley: New York, 1988, pp. 30–31.
52. Malmstadt, H.V.; Hadjiioannou, T.P. *Anal. Chem.* **1962**, 34, 452–455.
53. Pardue, H.L. *Anal. Chem.* **1963**, 35, 1240–1243.
54. Blaedel, W.J.; Hicks, G.P. *Anal. Chem.* **1962**, 34, 388–394.
- 55a. Blaedel, W.J.; Olson, C. *Anal. Chem.* **1964**, 36, 343–347.
- 55b. Blaedel, W.J.; Olson, C. U.S. Patent 3367849 (1968).
56. Roehrig, P.; Wolff, Ch.-M.; Schwing, J.P. *Anal. Chim. Acta.* **1983**, 153, 181–190.
57. Kadish, A.H.; Hall, D.A. *Clin. Chem.* **1965**, 11, 869–875.
58. Okuda, J.; Miwa, I. *Anal. Biochem.* **1971**, 39, 387–394.
59. Kadish, A.R.; Litle, R.L.; Sternberg, J.C. *Clin. Chem.* **1968**, 14, 116–131.
60. Skeggs, Jr., L.T. *Am. J. Clin. Pathol.* **1957**, 28, 311–322.
61. Mottola, H.A. *Anal. Chem.* **1981**, 53, 1312A–1316A.

- 62a. Reicher, V., Ed. *Technicon Bibliography 1967-1973*, Technicon Switzerland: Geneva.
- 62b. Reicher, V., Ed. *Technicon Bibliography Supplement 1*, 1974; Technicon Switzerland: Geneva.
- 62c. Reicher, V., Ed. *Technicon Bibliography Supplement 2*, 1975; Technicon Switzerland: Geneva.
63. Malmstadt, H.V.; and Piepmeier, E.H. *Anal. Chem.* **1965**, *37*, 34–44.
64. Guilbault, G.G.; Tyson, Jr., B.C.; Kramer, D.N.; Cannon, Jr., P.L. *Anal. Chem.* **1963**, *35*, 582–586.
65. Alexander, P.W.; Seegopaul, P. *Anal. Chim. Acta.* **1981**, *125*, 55–64.
66. White, J.W. *J. Assoc. Offic. Agric. Chem.* **1964**, *47*, 488–491.
67. Guilbault, G.G.; Brignac, Jr., P.J.; Zimmer, M. *Anal. Chem.* **1968**, *40*, 190–196.
68. Guilbault, G.G.; Brignac, Jr., P.J.; Juneau, M. *Anal. Chem.* **1968**, *40*, 1256–1263.
- 69a. Brandt, R.; Keston, A.S. *Anal. Biochem.* **1965**, *11*, 6–9.
- 69b. Keston, A.S.; and Brandt, R. *Anal. Biochem.* **1965**, *11*, 1–5.
- 70a. Kelly, T.A.; Christian, G.D. *Anal. Chem.* **1981**, *53*, 2110–2114.
- 70b. Kelly, T.A.; Christian, G.D. *Anal. Chem.* **1982**, *54*, 1444–1445.
71. Keston, A.S.; Brandt, R.; Kahan, E. *Anal. Biochem.* **1965**, *11*, 23–29.
72. Hsieh, Y.-S.; Crouch, S.R. *Anal. Chim. Acta.* **1993**, *284*, 159–166.
73. Barham, D.; Trinder, P. *Analyst.* **1972**, *97*, 142–145.
74. Wen, X.; Kipton, H.; Powell, J.; Christian, G.D.; Ruzicka, J. *Anal. Chim. Acta.* **1991**, *249*, 451–460.
75. Medina, M.J.; Bartolí, J.; Alonso, J.; Blanco, M.; Fuentes, J. *Anal. Lett.* **1984**, *17*, 385–396.
76. Mottola, H.A. *Analyst.* **1993**, *118*, 675–679.
77. Mottola, H.A.; Pérez-Bendito, D. *Anal. Chem.*, **1994**, *66*, 131R–162R.
78. Whitehead, T.P.; Kricka, L.J.; Carter, T.J.N.; Thorpe, G.H.G. *Clin. Chem.* **1979**, *25*, 1531–1546.
79. Auses, J.P.; Cook, S.L.; Maloy, J.T. *Anal. Chem.* **1975**, *45*, 244–249.
80. Igarashi, S.; Hinze, W.L. *Anal. Chem.* **1988**, *60*, 446–450.
- 81a. Pilosof, D.; Nieman, T.A. *Anal. Chem.* **1982**, *54*, 1698–1701.
- 81b. Malvoti, N.L.; Pilosof, D.; Nieman, T.A. *Anal. Chem.* **1984**, *56*, 2191–2195.
82. Mottola, H.A. *Quim. Anal.* **1989**, *8*, 119–128.
83. Chang, H.N.; Kyung, Y.-S.; Chung, B.H. *Biotech. Bioeng.* **1987**, *29*, 552–557.
84. Williams, III, D.C.; Huff, G.F.; Seitz, W.R. *Anal. Chem.* **1976**, *48*, 1003–1006.
85. Toren, C.; Burger, F. *Mikrochim. Acta.* **1968**, 538–545.
86. Ghosh, A.; Janic, V.; Sloviter, H.A. *Anal. Biochem.* **1970**, *38*, 270–276.
87. Saifer, A.; Gerstenfeld, S. *J. Lab. Clin. Med.* **1958**, *51*, 448–460.
- 88a. Nikolelis, D.P.; Mottola, H.A. *Anal. Chem.* **1965**, *50*, 1665–1670.
- 88b. Barlíková, A.; Svorc, J.; Miertus, S. *Anal. Chim. Acta.* **1991**, *247*, 83–87.
89. Thompson, R.Q.; Patel, H.R.; Andreadis, C. *Anal. Lett.* **1994**, *27*, 1201–1214.
90. Konecny, J. in *Survey of Progress in Chemistry*, Vol. 8; Academic Press: New York, 1977, pp. 195–251.
- 91a. Carr, P.J.; Bowers, L.D. *Immobilized Enzymes in Analytical and Clinical Chemistry*; Wiley: New York, 1980.
- 91b. Guilbault, G.G. *Analytical Uses of Immobilized Enzymes*; Marcel Dekker: New York, 1984.
- 91c. Wilson, G.S.; Thevenot, D.R. in *Biosensors. A Practical Approach*; A.E.G. Cass, Ed.; Oxford University Press: Oxford, 1990, Chapter 1.
- 92a. A. Wiseman, Ed. *Handbook of Enzyme Technology*, 2nd ed.; Ellis Horwood: Chichester, UK, 1985.

- 92b. J. Woodward, Ed. *Immobilized Cells and Enzymes*; IRL Press: Washington, DC, 1985.
- 92c. R. F. Taylor, Ed. *Protein Immobilization. Fundamentals and Applications*; Marcel Dekker: New York, 1991.
- 93a. Valcárcel, M.; Luque de Castro, M.D. *Flow Injection Analysis. Principles and Applications*; Ellis Horwood, Chichester, UK, 1987, pp. 345-349.
- 93b. Ruzicka, J.; Hansen, E.H. *Flow Injection Analysis*, 2nd ed.; Wiley: New York, 1988, Chapter 4.
94. Luque de Castro, M.D. *Trends Anal. Chem.* **1992**, *11*, 149-155.
- 95a. Matsumoto, K.; Baeza Baeza, J.J.; Mottola, H.A. *Anal. Chem.* **1993**, *65*, 636-639.
- 95b. Raba, J.; Mottola, H.A. *Anal. Biochem.* **1994**, *220*, 297-302.
96. Hicks, G.P.; Updike, S.J. *Anal. Chem.* **1966**, *38*, 726-730.
97. Hornby, W.E.; Fillippusson, H.; McDonald, A. *FEBS Lett.* **1970**, *9*, 8-10.
98. Inman, D.J.; Hornby, W.E. *Biochem J.* **1972**, *129*, 255-262.
- 99a. León, L.P.; Narayanan, S.; Dellenbach, R.; Horvath, C. *Clin. Chem.* **1976**, *22*, 1017-1023.
- 99b. León, L.P.; Sansur, M.; Snyder, L.R.; Horvath, C. *Clin. Chem.* **1977**, *23*, 1556-1562.
- 99c. Werner, M.; Mohrbacher, R.J.; Riendeau, C.J.; Murador, E.; Cambiaghi, S. *Clin. Chem.* **1979**, *25*, 20-23.
100. Campbell, J.; Chawla, A.S.; Chang, T.M.S. *Anal. Biochem.* **1977**, *83*, 330-335.
101. Endo, J.; Tabata, M.; Okada, S.; Murachi, T. *Clin. Chim. Acta.* **1979**, *95*, 411-417.
102. Joseph, M.D.; Kasprzak, D.J.; Crouch, S.R. *Clin. Chem.* **1977**, *23*, 1033-1036.
103. Gorton, L.; Ögren, L. *Anal. Chim. Acta.* **1981**, *130*, 45-53.
104. Olsson, B.; Ögren, L.; Johansson, G. *Anal. Chim. Acta.* **1983**, *145*, 101-108.
105. Stults, C.L.M.; Wade, A.P.; Crouch, S.R. *Anal. Chem.* **1987**, *59*, 2245-2247.
106. Garn, M.; Gisin, M.; Thommen, C. *Biotech. Bioeng.* **1989**, *34*, 423-428.
107. Ruzicka, J.; Flossdorf, J.; *Anal. Chim. Acta.* **1989**, *218*, 291-301.
108. Updike, S.J.; Hicks, G.P. *Science.* **1967**, *158*, 270-272.
109. Bergmeyer, H.U.; Hagen, A. *Fresenius' Z. Anal. Chem.* **1972**, *261*, 333-3336.
- 110a. Weibel, M.K.; Dritschilo, W.; Bright, H.J.; Humphrey, A.E. *Anal. Biochem.* **1973**, *52*, 402-414.
- 110b. Kunz, H.J.; Stastny, M. *Clin. Chem.* **1974**, *20*, 1018-1022.
111. Campbell, J.; Hornby, W.E.; Morris, D.L. *Biochim. Biophys. Acta.* **1975**, *384*, 307-316.
112. Watson, B.; Stifel, D.N.; Semersky, F.E. *Anal. Chim. Acta.* **1979**, *106*, 233-242.
- 113a. Masoom, M.; Townshend, A. *Anal. Chim. Acta.* **1984**, *166*, 111-118.
- 113b. Masoom, M.; Townshend, A. *Anal. Chim. Acta.* **1985**, *171*, 185-194.
114. Uditha de Alwis, W.; Hill, B.S.; Meiklajohn, B.I.; Wilson, G.S. *Anal. Chem.* **1987**, *59*, 2688-2691.
115. Olsson, L.; Mandenius, C.F. *Anal. Chim. Acta.* **1989**, *224*, 31-38.
116. Laurell, T. *J. Med. Eng. Technol.* **1992**, *16*, 187-193.
117. Huang, Y.L.; Khoo, S.B.; Yap, M.G.S. *Anal. Chim. Acta.* **1993**, *283*, 763-771.
118. Arica, M.Y.; Hasirci, V. *Biomaterials.* **1993**, *14*, 809-816.
119. Boutelle, M.G.; Fellows, L.K.; Cook, C. *Anal. Chem.* **1992**, *64*, 1790-1794.
- 120a. Bostick, D.T.; Hercules, D.M. *Anal. Lett.* **1974**, *7*, 347-353.
- 120b. Bostick, D.T.; Hercules, D.M. *Anal. Chem.* **1975**, *47*, 447-451.
- 120c. Williams, D.C.; Huff, G.F.; Seitz, W.R. *Clin. Chem.* **1976**, *22*, 372-374.
121. Miller, J.N.; Rocks, B.F.; Thorburn Burns, D. *Anal. Chim. Acta.* **1977**, *93*, 353-356.

122. Hara, T.; Toriyama, M.; Imaki, M. *Bull. Chem. Soc. Jpn.* **1982**, *55*, 1854–1857.
123. Petersson, B.A.; Hansen, E.H.; Ruzicka, J. *Anal. Lett.* **1986**, *19*, 649–665.
- 124a. Nielsen, J.; Nikolajsen, K.; Benthin, S.; Villadsen, J. *Anal. Chim. Acta.* **1990**, *237*, 165–175.
- 124b. S. Benthin, S.; J. Nielsen, J.; J. Villadsen, J. *Anal. Chim. Acta.* **1991**, *247*, 45–50.
- 124c. Benthin, S.; Nielsen, J.; Villadsen, J. *Anal. Chim. Acta.* **1992**, *261*, 145–153.
125. Huang, Y.L.; Li, S.Y.; Dremel, B.A.A.; Bilitewski, U.; Schmid, R.D. *J. Biotech.* **1991**, *18*, 161–172.
126. Martin, G.B.; Rechnitz, G.A. *Anal. Chim. Acta.* **1993**, *281*, 557–568.
127. Koerner, Jr., P.J.; Nieman, T.A. *J. Chromatogr.* **1988**, *449*, 217–228.
128. Thompson, R.Q.; Crouch, S.R. *Anal. Chim. Acta.* **1984**, *159*, 337–342.
129. Kiang, S.W.; Kuan, J.W.; Kuan, S.S.; Guilbault, G.G. *Clin. Chem.* **1976**, *22*, 1378–1376.
- 130a. Matsumoto, K.; Baeza Baeza, J.J.; Mottola, H.A. *Anal. Chem.* **1993**, *65*, 636–639.
- 130b. Baeza Baeza, J.J.; Matsumoto, K.; Mottola, H.A. *Quim. Anal.* **1993**, *12*, 12–17.
- 130c. Matsumoto, K.; Baeza Baeza, J.J.; Mottola, H.A. *Anal. Chem.* **1993**, *65*, 1658–1661.
- 130d. Baeza Baeza, J.J.; Matsumoto, K.; Mottola, H.A. *Anal. Chim. Acta.* **1993**, *283*, 785–793.
131. Raba, J.; Li, S.; Mottola, H.A. *Anal. Chim. Acta.*, **1995**; *300*, 299–305.
132. Narang, U.; Prasad, P.N.; Bright, F.V.; Ramanathan, K.; Kumar, N.D.; Malhotra, B.D.; Kamalasanan, M.N.; Chandra, S. *Anal. Chem.* **1994**, *66*, 3139–3144.
133. Clark, Jr., L.C.; Lyons, C. *Ann. N. Y. Acad. Sci.* **1962**, *102*, 29–45.
134. Updike, S.J.; Hicks, G.P. *Nature* **1967**, *214*, 986–988.
135. Begum, K.D.; Mottola, H.A. *Anal. Biochem.* **1984**, *142*, 1–6.
136. Williams, D.L.; Doig, Jr., A.R.; Korosi, A. *Anal. Chem.* **1970**, *42*, 118–121.
137. Albery, W.J.; Bartlett, P.N. *J. Electroanal. Chem.* **1985**, *194*, 211–222.
138. Gunasingham, H.; Tan, C.-H.; Aw, T.-C. *Anal. Chim. Acta.* **1990**, *234*, 321–330.
- 139a. Guilbault, G.G.; Lubrano, G.J. *Anal. Chim. Acta.* **1972**, *60*, 264–256.
- 139b. Guilbault, G.G.; Lubrano, G.J. *Anal. Chim. Acta.* **1973**, *64*, 439–445.
140. Matuszewski, W.; Trojanowicz, M. *Analyst.* **1988**, *113*, 735–738.
141. Shu, F.R.; Wilson, G.S. *Anal. Chem.* **1976**, *48*, 1679–1686.
142. Kamin, R.A.; Wilson, G.S. *Anal. Chem.* **1980**, *52*, 1198–1205.
143. Bourdillon, C.; Bourgeois, J.P.; Thomas, D. *J. Am. Chem. Soc.* **1980**, *102*, 4231–4235.
144. Wu, H.M.; Olier, R.; Jaffrezie-Renault, N.; Clechet, P.; Nyamsi, A.; Martelet, C. *Electrochim. Acta.* **1994**, *39*, 327–331.
145. Chi, Q.; Dong, S. *Anal. Chim. Acta.* **1993**, *278*, 17–23.
146. Jönsson, G.; Gorton, L. *Anal. Lett.* **1987**, *20*, 839–855.
147. Liu, C.C.; Wingard, Jr., L.B.; Wolfson, Jr., S.K.; Yao, S.J.; Drash, A.L.; Schiller, J.G. *J. Electroanal. Chem.* **1979**, *104*, 19–26.
148. Shimizu, Y.; Morita, K. *Anal. Chem.* **1990**, *62*, 1498–1501.
149. Vopel, T.; Ladde, A.; Müller, H. *Anal. Chim. Acta.* **1991**, *251*, 117–120.
150. Bélanger, D.; Brassard, E.; Fortier, G. *Anal. Chim. Acta.* **1990**, *228*, 311–315.
151. Cardosi, M.F.; Birch, S.W. *Anal. Chim. Acta.* **1993**, *276*, 69–74.
152. Wang, J.; Chen, Q. *Anal. Chem.* **1994**, *66*, 1007–1011.
- 153a. Gough, D.A.; Lucisano, J.Y.; Tse, P.H.S. *Anal. Chem.* **1985**, *57*, 2351–2357.
- 153b. Lucisano, J.Y.; Gough, D.A. *Anal. Chem.* **1988**, *60*, 1272–1281.
154. Yokoyama, K.; Lee, S.M.; Tamiya, E.; Karube, E.; Nakajima, K.; Uchiyama, S.;

- Suzuki, S.; Akiyama, M.; Masuda, Y. *Anal. Chim. Acta.* **1992**, *263*, 101–110.
155. Soldatkin, A.P.; El'skaya, A.V.; Shul'ga, A.A.; Netchiporouk, L.I.; Hendji, A.M.N.; Jaffrezic-Renault, N.; Martelet, C. *Anal. Chim. Acta.* **1993**, *283*, 695–701.
156. Mizutani, F.; Yabuki, S.; Katsura, T. *Anal. Chim. Acta.* **1993**, *274*, 201–207.
157. Higson, S.P.J.; Vadgama, P.M. *Anal. Chim. Acta.* **1993**, *271*, 125–133.
158. Umaña, M.; Waller, J. *Anal. Chem.* **1986**, *58*, 2979–2983.
159. Coche-Guérente, L.; Deronzier, A.; Maille, P.; Moulet, J. *Anal. Chim. Acta.* **1994**, *289*, 143–153.
160. Du Poet, P.; Miyamoto, S.; Murakami, T.; Kimura, J.; Karube, I. *Anal. Chim. Acta.* **1990**, *235*, 255–263.
- 161a. Malitesta, C.; Palmisano, F.; Torsi, L.; Zambonin, P.G. *Anal. Chem.* **1990**, *62*, 2735–2740.
- 161b. Lowry, J.P.; McAteer, K.; El Atrash, S.S.; Duff, A.; O'Neill, R.D. *Anal. Chem.* **1994**, *66*, 1754–1761.
162. Razumas, V.; Kanapienienė, J.; Nylander, T.; Engström, S.; Larsson, K. *Anal. Chim. Acta.* **1994**, *289*, 155–162.
163. Zilkha, E.; Koshy, A.; Obrenovitch, T.P.; Bennetto, H.P.; Symon, L. *Anal. Lett.* **1994**, *27*, 453–473.
164. De Benedetto, G.E.; Malitesta, C.; Zambonin, C.G. *J. Chem. Soc., Faraday Trans.* **1994**, *90*, 1495–1499.
165. Johnson, K.W.; Bryan-Poole, N.; Mastroto-taro, J. *Electroanalysis.* **1994**, *6*, 321–326.
166. Centonze, D.; Guerrieri, A.; Palmisano, F.; Torsi, L.; Zambonin, P.G. *Fresenius' J. Anal. Chem.* **1994**, *349*, 497–501.
167. Schläpfer, P.; Mindt, W.; Racine, Ph. *Clin. Chim. Acta.* **1974**, *57*, 283–289.
168. Kulys, J.J.; Samalius, A.S.; Svirnickas, G.-J.S. *FEBS Lett.* **1980**, *114*, 7–10.
169. Kulis, Y.Y.; Chenas, N.K. *Biokhimiya* **1981**, *46*, 1780–1786; *Biochemistry* (Engl. Transl.) **1981**, *46*, 1401–1407.
170. Cass, A.E.G.; Davis, G.; Francis, D.G.; Hill, H.A.O.; Aston, W.J.; Higgins, I.J.; Plotkin, E.V.; Scott, L.D.L.; Turner, A.P.F. *Anal. Chem.* **1984**, *56*, 667–671.
- 171a. Wang, J.; Wu, L.H.; Li, R.; Sanchez, J. *Anal. Chim. Acta.* **1990**, *228*, 251–257.
- 171b. Hale, P.D.; Lan, H.L.; Boguslavsky, L.I.; Karan, H.I.; Okamoto, Y.; Skotheim, T.A. *Anal. Chim. Acta.* **1991**, *251*, 121–128.
- 171c. Gorton, L.; Karan, H.I.; Hale, P.D.; Inagaki, T.; Okamoto, Y.; Stokheim, T.A. *Anal. Chim. Acta.* **1990**, *228*, 23–30.
- 171d. Lange, M.A.; Chambers, J.Q. *Anal. Chim. Acta.* **1985**, *175*, 89–97.
172. Hu, J.; Turner, A.P.F. *Anal. Lett.* **1991**, *24*, 15–24.
173. Ikeda, T.; Katasho, I.; Kaei, M.; Senda, M. *Agric. Biol. Chem.* **1984**, *48*, 1969–1976.
174. Kaku, T.; Karan, H.I.; Okamoyo, Y. *Anal. Chem.* **1994**, *66*, 1231–1235.
175. Zhang, Z.R.; Bao, W.-F.; Liu, C.-C. *Talanta.* **1994**, *41*, 875–879.
176. Crumbliss, A.L.; Hill, H.A.O.; Page, D.J. *J. Electroanal. Chem.* **1986**, *206*, 327–331.
177. Taniguchi, I.; Miyamoto, S.; Tomimura, S.; Hawkridge, F.M. *J. Electroanal. Chem.* **1988**, *240*, 333–339.
178. Hale, P.D.; Bogulavsky, L.I.; Karan, H.I.; Lan, H.L.; Lee, H.S.; Okamoto, Y.; Skotheim, T.A. *Anal. Chim. Acta.* **1991**, *248*, 155–161.
179. Rosen-Margalit, I.; Bettelheim, A.; Rishpon, J. *Anal. Chim. Acta.* **1993**, *281*, 327–333.
- 180a. Jönsson, G.; Gorton, L. *Biosensors* **1985**, *1*, 237–245.
- 180b. Cardosi, M.F. *Anal. Proc.* **1987**, *24*, 143–145.
181. Kulys, J.; Buch-Rasmussen, T.; Bechgaard, K.; Marcinkeviciene, J.; Christensen, J.B.; Hansen, E.H. *FEBS Letters* **1993**, *329*, 205–209.
182. Newman, J.D.; Turner, A.P.F.; Marraza, G. *Anal. Chim. Acta.* **1992**, *262*, 13–17.
183. Bartlett, P.N.; Birkin, P.R. *Anal. Chem.* **1994**, *66*, 1552–1559.

- 184a. Gregg, B.; Heller, A. *Anal. Chem.* **1990**, *62*, 258–263.
- 184b. Gregg, B.A.; Heller, A. *J. Phys. Chem.* **1991**, *95*, 5970–5975.
- 184c. Gregg, B.A.; Heller, A. *J. Phys. Chem.* **1991**, *95*, 5976–5980.
- 184d. Uhegbu, C.E.; Lim, K.B.; Pardue, H.L.; *Anal. Chem.* **1993**, *65*, 2443–2451.
185. Rohde, E.; Dempsey, E.; Smith, M.R.; Vos, J.G.; Emons, H. *Anal. Chim. Acta.* **1993**, *278*, 5–16.
186. Ohara, J.T.; Rajagopalan, R.; Heller, A. *Anal. Chem.* **1993**, *65*, 3512–3517.
187. Ohara, T.J.; Rajagopalan, R.; Heller, A. *Anal. Chem.* **1994**, *66*, 2451–2457.
188. Kulys, J.; Hansen, H.E.; Buch-Rasmussen, T.; Wang, J.; Ozsoz, M. *Anal. Chim. Acta.* **1994**, *288*, 193–196.
189. Gunasingham, H.; Tan, C.-H. *Anal. Chim. Acta.* **1990**, *229*, 83–91.
190. Fraser, D.M. *Anal. Lett.* **1994**, *27*, 2039–2053.
191. Motta, N.; Guadalupe, A.R. *Anal. Chem.* **1994**, *66*, 566–571.
- 192a. Céspedes, F.; Martínez-Fàbrega, E.; Alegret, S. *Anal. Chim. Acta.* **1993**, *284*, 21–26.
- 192b. Céspedes, F.; Martínez-Fàbrega, E.; Bartrolí, J.; Alegret, S. *Anal. Chim. Acta.* **1993**, *273*, 409–417.
193. Sakslund, H.; Wang, J.; Hammerich, O. *J. Electroanal. Chem.* **1994**, *374*, 71–79.
- 194a. Koopal, C.G.J.; de Ruiter, B.; Nolte, R.J.M. *J. Chem. Soc. Chem. Commun.* **1991**, 1691–1692.
- 194b. Koopal, C.G.J.; Freites, M.C.; Nolte, R.J.M.; de Ruiter, B.; Schasfoort, R.B.M. *Biosens. Bioelectron.* **1992**, *7*, 461–471.
195. Kuwabata, S.; Martin, C.R. *Anal. Chem.* **1994**, *66*, 2757–2762.
196. Moore, T.J.; Nam, G.G.; Pipes, L.C.; Coury, Jr., L.A. *Anal. Chem.* **1994**, *66*, 3158–3163.
- 197a. Degani, Y.; Heller, A. *J. Phys. Chem.*, **91**, 1285–1289.
- 197b. Degani, Y.; Heller, A. *J. Am. Chem. Soc.* **1988**, *110*, 2615–2620.
- 197c. Heller, A.; Degani, Y. in *Redox Chemistry and Interfacial Behavior of Biological Molecules*; G. Dryhurst and K. Niki, Eds.; Plenum: New York, 1988, pp. 151–171.
198. Yon-Hin, B.F.Y.; Lowe, C.R. *J. Electroanal. Chem.* **1994**, *374*, 167–172.
199. Csöregi, E.; Quinn, C.P.; Schmidtke, D.W.; Lindquist, S.-E.; Pishko, M.V.; Ye, L.; Katakis, I.; Hubbell, J.A.; Heller, A. *Anal. Chem.* **1994**, *66*, 3131–3138.
200. Matthews, D.R.; Bown, E.; Watson, A.; Holman, R.R.; Steemson, J.; Hughes, S.; Scott, D. *Lancet.* **1987**, *i*, 778–779.
- 201a. Wingard, Jr., L.B.; Ferrance, P.J. Concepts, biological components, and scope of biosensors, in *Biosensors with Fiber Optics*; D.L. Wise and L.B. Wingard, Jr., Eds.; Humana Press: Clifton, NJ, 1991, pp. 1–23.
- 201b. Arnold, M.A. Fiber optic biosensors: Recent advances and future prospects, in *Immunochemical Assay and Biosensor Technology for the 1990s*; R.M. Nakamura, Y. Kasahara, G.A. Rechnitz, Eds.; American Society for Microbiology: Washington, DC, 1992, pp. 311–333.
- 201c. Cammann, K.; Lemke, U.; Rohen, A.; Sander, J.; Wilken, H.; Winter, B. *Angew. Chem. Int. Ed. Engl.* **1991**, *30*, 516–539.
- 201d. Tran, M.C. *Biosensors*; Chapman and Hall: New York, 1993.
- 202a. Seitz, W.R.; *Anal. Chem.* **1984**, *56*, 16A–34A.
- 202b. Arnold, M.A.; Meyerhoff, M.E. *CRC Crit. Rev. Anal. Chem.* **1988**, *20*, 149–196.
- 202c. Wolfbeis, O.S. in *Molecular Luminescence Spectroscopy: Methods and Applications-Part II*; S. J. Schulman, Ed.; Wiley: New York, 1988, Chapter 3.
- 202d. Wolfbeis, O.S. *Fresenius' Z. Anal. Chem.* **1986**, *325*, 387–392.
- 202e. Schaffar, B.; Wolfbeis, O. in *Biosensor Principles and Applications*; L.J. Blum and P.R. Coulet, Eds.; Dekker: New York, 1991.
203. Trettnak, W.; Wolfbeis, O.S. *Anal. Chim. Acta.* **1989**, *221*, 195–203.
- 204a. Uwira, N.; Opitz, N.; Lübbers, D.W. *Adv. Exp. Med. Biol.* **1984**, *169*, 913–921.

- 204b. Kroneis, H.W.; Marsoner, H.J. in *Biosensors International Workshop 1987*; R.D. Schmid, G.G. Guilbault, I. Karube, H.L. Schmidt, L.B. Wingard, Eds.; Verlag Chemie: Weinheim, 1987, pp. 303–304.
205. Trettnak, W.; Leiner, M.J.P.; Wolfbeis, O.S. *Analyst*. **1988**, *113*, 1519–1523.
206. Schaffar, B.P.H.; Wolfbeis, O.S. *Biosens. Bioelectron*. **1990**, *5*, 137–148.
207. Moreno-Bondi, M.C.; Wolfbeis, O.S.; Leiner, M.J.P.; Schaffar, B.P.H. *Anal. Chem*. **1990**, *62*, 2377–2380.
208. Goldfinch, M.J.; Lowe, C.R. *Anal. Biochem*. **1984**, *138*, 430–436.
209. Trettnak, W.; Leiner, M.J.P.; Wolfbeis, O.S. *Biosensors*. **1988**, *4*, 15–26.
210. Weaver, J.C.; Cooney, C.L.; Fulton, S.P.; Schuler, P.; Tannenbaum, S.R. *Biochim. Biophys. Acta*. **1976**, *452*, 285–291.
- 211a. Grime, J.K. *Anal. Chim. Acta*. **1980**, *118*, 191–225.
- 211b. Danielsson, B. *Appl. Biochem. Biotechnol*. **1982**, *7*, 127–134.
212. Mosbach, K.; Danielson, B. *Anal. Chem*. **1981**, *53*, 83A–94A.
213. Johansson, A. *Protides Biol. Fluids Proc. Colloq*. **1973**, *20*, 567–570.
214. Muehlbauer, M.J.; Guilbeau, E.J.; Towe, B.C. *Anal. Chem*. **1989**, *61*, 77–83.
215. Mosbach, K.; Danielson, B.; Borgerud, A.; Scott, M. *Biochim. Biophys. Acta*. **1975**, *403*, 256–265.
216. Schmidt, H.L.; Krisam, G.; Grenner, G. *Biochim. Biophys. Acta*. **1976**, *429*, 283–290.
217. Krisan, G. *Fresenius' Z. Anal. Chem*. **1978**, *290*, 130–131.
218. Mattiasson, B.; Danielsson, B.; Mosbach, K. *Anal. Lett*. **1976**, *9*, 217–134.
- 219a. Mattiasson, B.; Danielsson, B.; Mosbach, K. *Anal. Lett*. **1976**, *9*, 867–889.
- 219b. Danielsson, B.; Gadd, K.; Mattiasson, B.; Mosbach, K. *Clin. Chim. Acta*. **1977**, *81*, 163–175.
- 219c. Kiba, N.; Tomiyasu, T.; Furusawa, M. *Talanta*. **1984**, *30*, 131–132.
220. Tran-Minh, C.; Vallin, D. *Anal. Chem*. **1978**, *50*, 1874–1878.
221. Bataillard, P.; Steffgen, E.; Haemmerli, S.; Manz, A.; Widmer, H.M. *Biosens. Bioelectron*. **1993**, *8*, 89–98.
222. Nakamura, R.M. in *Immunochemical Assays and Biosensor Technology for the 1990s*; R.M. Nakamura, Y. Kasahara, G.A. Rechnitz, Eds.; American Chemical Society for Microbiology: Washington, D. C., 1992, p. 3.
223. Wisdom, G.B. *Clin. Chem*. **1976**, 1243–1255.
224. Arnon, R. in *The Antigens*, Vol. 1; M. Sela, Ed., Academic Press: New York, pp. 87–159.
- 225a. Cass, A.G.E. *Biosensors: A Practical Approach*; Oxford University Press: New York, 1990.
- 225b. Avrameas, S. *Immunochemistry*. **1969**, *6*, 831–836.
226. Gosling, J.P. *Clin. Chem*. **1990**, *36*, 1408–1427.
227. Masseyeff, R.; Maiolini, R.; Bouron, V. *Bio-medicine*. **1973**, *19*, 314–317.
228. Maiolini, R.; Ferrua, B.; Masseyeff, R. *J. Immunol. Methods*. **1975**, *6*, 355–362.
229. Maiolini, R. Masseyeff, R. *J. Immunol. Methods*. **1975**, *8*, 223–234.
230. Mattiasson, B. *FEBS Lett*. **1977**, *77*, 107–110.
- 231a. Morris, D.L.; Ellis, P.B.; Carrico, R.J.; Yeager, F.M.; Schroeder, H.R.; Albarella, J.P.; Boguslaski, R.C. *Anal. Chem*. **1981**, *53*, 658–665.
- 231b. Tyhach, R.J.; Rupchock, P.A.; Pendergrass, J.H.; Skjold, A.C.; Smith, P.J.; Johnson, R.D.; Albarella, J.P.; Profitt, J.A. *Anal. Chem*. **1981**, *53*, 1499–1504.
232. Dias, J.A.; Driskell, W.J.; Reichert, Jr., L.E. *Anal. Biochem*. **1981**, *114*, 268–275.
233. Ngo, T.T.; Lenhoff, H.M. *Biochem. Biophys. Res. Commun*. **1983**, *114*, 1097–1103.

234. Chen, R.; Weng, L.; Sizto, N.C.; Osorio, B.; Hsu, C.-J.; Rodgers, R.; Litman, D.J. *Clin. Chem.* **1984**, *30*, 1446–1451.
235. Maeda, M.; Tsuji, A. *Anal. Chim. Acta.* **1985**, *167*, 241–248.
236. Arakawa, H.; Maeda, M.; Tsuji, A. *Clin. Chem.* **1985**, *31*, 430–434.
237. Uditha de Alwis, W.; Wilson, G.S. *Anal. Chem.* **1985**, *57*, 2754–2756.
238. Robinson, G.A.; Hill, H.A.O.; Philo, R.D.; Gear, J.M.; Rattle, S.J.; Forrest, G.C. *Clin. Chem.* **1985**, *31*, 1449–1452.
239. Robinson, G.A.; Cole, V.M.; Rattle, S.J.; Forrest, G.C. *Biosensors.* **1986**, *2*, 45–57.
240. Robinson, G.A.; Martinazzo, G.; Forrest, G.C. *J. Immunoassay.* **1986**, *7*, 1–15.
241. Tsuji, A.; Maeda, M.; Arakawa, H.; Shimizu, S.; Ikegami, T.; Sudo, Y. *J. Steroid. Biochem.* **1987**, *27*, 33–40.
242. Gyss, C.; Bourdillon, C. *Anal. Chem.* **1987**, *59*, 2350–2355.
243. de Alvis, U.; Wilson, G.S. *Anal. Chem.* **1987**, *59*, 2786–2789.
244. Robinson, G.A.; Cole, V.M.; Forrest, G.C. *Biosensors.* **1987/88**, *3*, 147–160.
245. Luong, J.H.T.; Prusak-Sochaczewski, E. *Anal. Lett.* **1990**, *23*, 1809–1826.
246. Tsuji, I.; Eguchi, H.; Yasukouchi, K.; Unoki, M.; Taniguchi, I. *Biosen. Bioelec.* **1990**, *5*, 87–101.
247. Blais, B.W.; Yamazaki, H. *Immunol. Invest.* **1992**, *21*, 581–588.
248. Hosoda, H.; Fukuda, K.; Goto, J. *Chem. Pharm. Bull. (Tokyo).* **1992**, *40*, 1325–1326.
249. V. Worthington, Ed., *Worthington Enzyme Manual*; Worthington Biochem. Corp.: Freehold, NJ, 1993, p. 185.