



Since January 2020 Elsevier has created a COVID-19 resource centre with free information in English and Mandarin on the novel coronavirus COVID-19. The COVID-19 resource centre is hosted on Elsevier Connect, the company's public news and information website.

Elsevier hereby grants permission to make all its COVID-19-related research that is available on the COVID-19 resource centre - including this research content - immediately available in PubMed Central and other publicly funded repositories, such as the WHO COVID database with rights for unrestricted research re-use and analyses in any form or by any means with acknowledgement of the original source. These permissions are granted for free by Elsevier for as long as the COVID-19 resource centre remains active.

Glycosylation in Intestinal Epithelium

DOUGLAS J. TAATJES* AND JÜRGEN ROTH†

Interdepartmental Electron Microscopy, Biocenter, University of Basel, CH-4056 Basel, Switzerland

I. Introduction

A great deal of interest has been focused in the last few decades on elucidating the mechanisms and cellular locations of glycosylation reactions. This interest has arisen as the result of many divergent disciplines converging on a central, fundamental question: Where and how are sugar residues added on to proteins and lipids during their journey from the sites of synthesis to delivery at final destinations? This question is of practical concern to biochemists, cell biologists, virologists, and cancer biologists, to name a few, and has emerged from the realization that the sugar moieties of glycoconjugates are involved in a myriad of events related to recognition phenomena. This is especially true of oligosaccharide chains present on plasma membrane glycoconjugates. The first version of the fluid mosaic model of the plasma membrane published in 1972 (Singer and Nicolson, 1972) depicting a lipid bilayer containing integral and peripheral proteins, neglected the existence of the sugar constituents of these molecules. Indeed, almost all plasma membrane proteins are glycoproteins. Given the knowledge that the sugar moieties of glycoconjugates are found on the extracellular side of plasma membranes, it is quite easy to envision their involvement in recognition of another cell, bacterium, or virus (Rademacher *et al.*, 1988). This idea took on added significance with reports from the 1960s that cancer cell plasma membranes were different from those of normal cells with respect to their oligosaccharide composition (Aub *et al.*, 1963, 1965a,b; Burger and Goldberg, 1967). Although time and much subsequent research have revealed the oversimplification of this notion of malignancy and metastasis, it nevertheless certainly generated a flurry of activity aimed at understanding glycosylation. Perhaps of equal importance was the finding that many pathogenic organisms bind to and gain entry to cells through recognition of sugar molecules present at the cell surface (Paulson, 1985; Kocourek, 1986; Sharon and Lis, 1989). Regardless of the driving forces, the result has been an understanding in detail of some aspects of the process of glycosylation.

*Present Address: Department of Pathology, University of Vermont, Burlington, Vermont 05405

†Present Address: Department of Cell and Molecular Pathology, Institute of Pathology, University of Zürich, CH-8091 Zürich, Switzerland

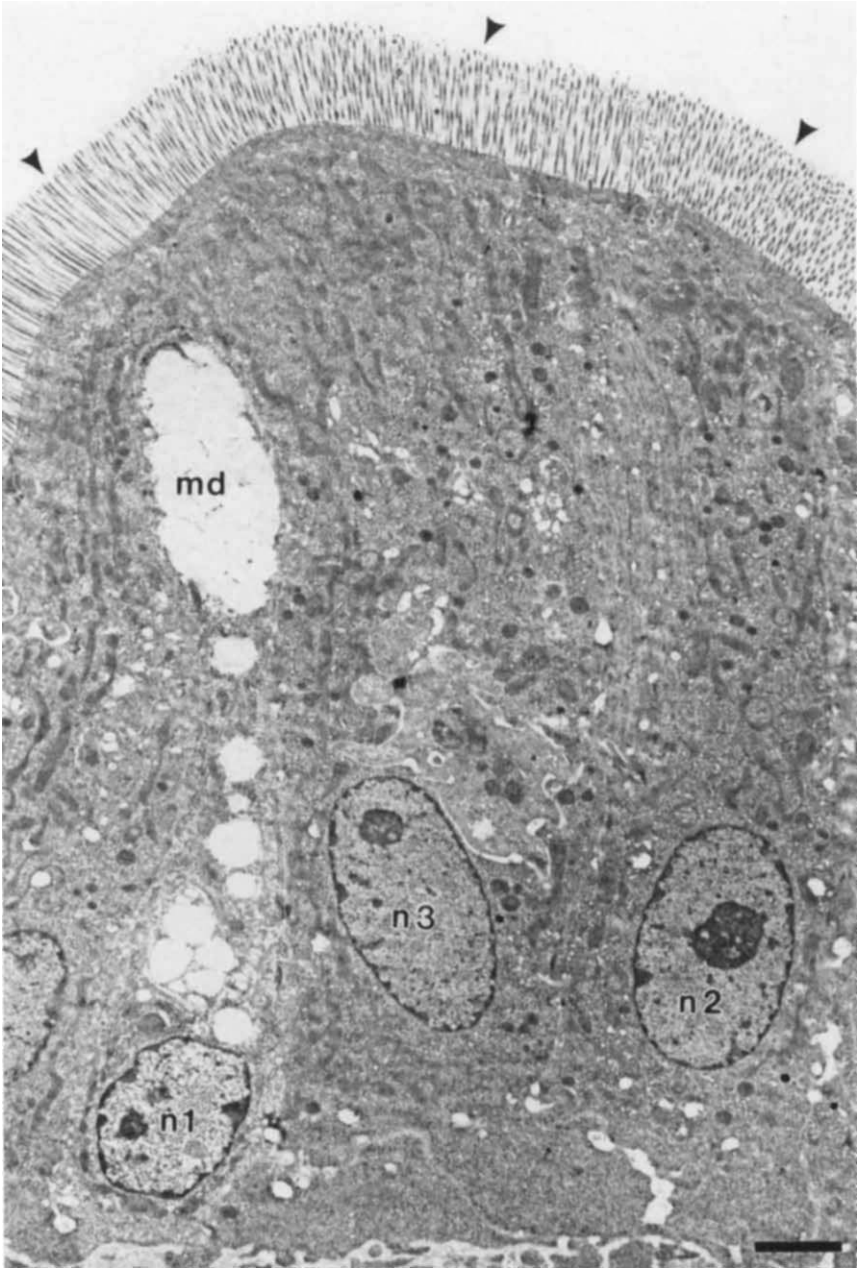

The intestinal epithelium represents a good model system in which to study the glycosylation process. From a simplistic viewpoint, the intestinal epithelium is composed of two basic epithelial cell types; the absorptive enterocyte and the mucus-producing goblet cell (Figs. 1 and 2). These two cell types differ both in form and function, yet are derived from a singular precursor cell (Leblond and Messier, 1958; Cheng and Leblond, 1974). This affords the opportunity to study glycosylation in neighboring but distinct cells. From a historical perspective, the intestine was chosen as one of the earliest systems for the cytochemical investigation of glycosylation. Indeed, in two classic papers investigating intestinal epithelial cells, Neutra and Leblond (1966a,b) provided the first demonstration that complex sugars are added to glycoconjugates in the Golgi apparatus. They injected tritiated hexoses ($[^3\text{H}]$ glucose and $[^3\text{H}]$ galactose) into rats, and found that autoradiographic grains were first localized over the Golgi apparatus cisternal stack. Radioactivity was then followed into the mucus droplets of the goblet cell and into the plasma membrane of absorptive cells. Further, classical histochemical staining techniques, applied to electron microscopically visualize periodate-reactive carbohydrates (Rambourg *et al.*, 1969), demonstrated reaction in the Golgi apparatus and plasma membrane of intestinal epithelial cells, as previously reported for acid mucopolysaccharides using colloidal iron staining (Revel, 1964; Wetzel *et al.*, 1966; Berlin, 1967).

Likewise, the basic morphology and physiology of the intestinal tract provide an ideal system in which to study glycosylation as it relates to development and differentiation (Fig. 3). The harsh environment of the intestinal lumen results in continuous loss of epithelial cells through sloughing into the lumen. Gastrointestinal epithelial renewal ensues through the processes of cell proliferation, migration, and differentiation (Eastwood, 1977). This renewal occurs in discrete proliferative zones along the gastrointestinal tract. In the small intestine, this proliferative zone is restricted to the base of the crypts, whereas in the large intestine it is less restrictive, occurring in the basal two thirds of the crypt. The definitive autoradiographic studies of Leblond and co-workers have established that in both small (Cheng, 1974; Cheng and Leblond, 1974) and large intestine (Chang and Leblond, 1971), a ring of undifferentiated stem cells situated in the crypts divide to produce daughter cells committed to differentiate into

FIG. 1. Low-power electron micrograph showing the surface epithelium from the chick duodenum. In this and all subsequent micrographs, the tissue was lightly fixed in aldehydes (without postfixation in osmium tetroxide), followed by low temperature dehydration and embedding in Lowicryl K4M. Thus, membrane delineation is different from that seen in routinely processed tissues. The surface lining the intestinal lumen is composed mainly of two epithelial cell types: the mucus-producing goblet cell interspersed among the absorptive enterocyte. Both cell types possess an elaborate apical plasma membrane called the brush border (arrowheads), which is covered by a layer of mucus rich in glycoconjugates. (md) Mucus droplets; (n1) goblet cell nucleus; (n2) absorptive cell nucleus; (n3) nucleus of migrating lymphoid cell. X 1400. Bar = 6.7 μm .

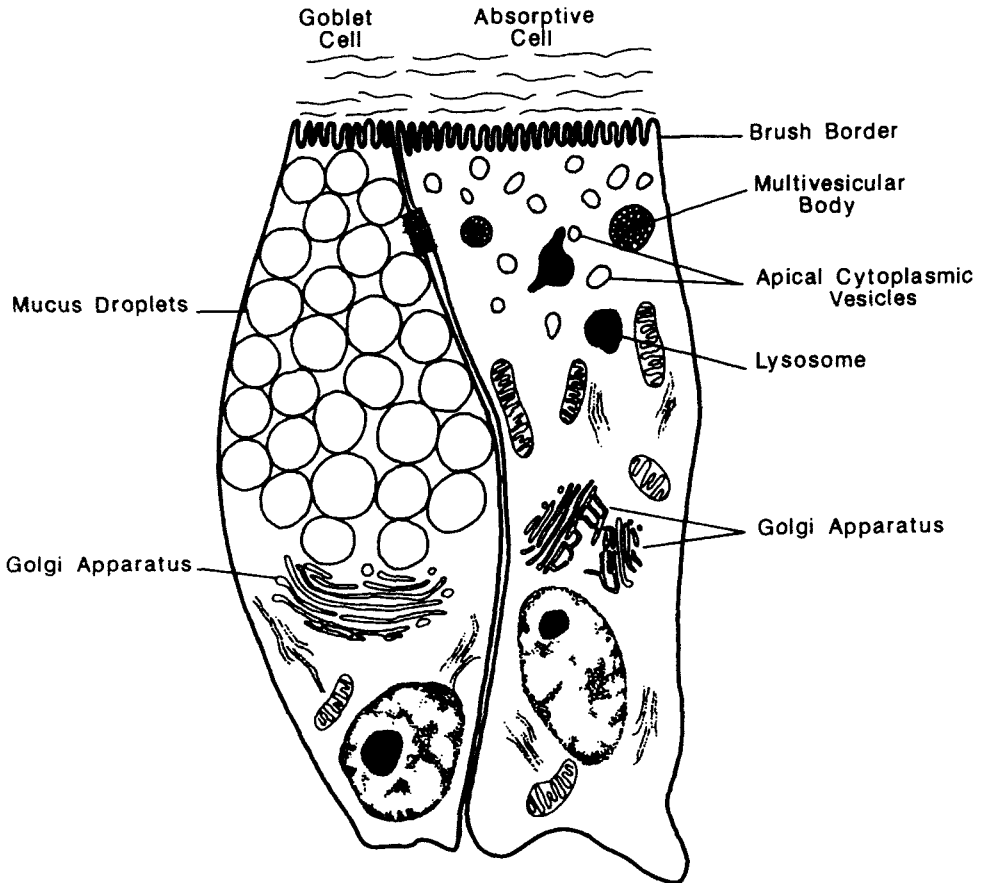

FIG. 2. Schematic drawing illustrating the morphology of the two basic epithelial cell types lining the intestinal tract. Compare this drawing with the electron micrograph presented in Fig. 1. Of particular importance with respect to glycosylation are the Golgi apparatus, apical and basolateral plasma membrane domains, absorptive cell apical cytoplasmic vesicles, and goblet cell mucus droplets.

absorptive (columnar), goblet, and endocrine cells. The mechanisms guiding proliferation and migration are not fully understood (Potten and Loeffler, 1987), however, migration time from crypt to surface epithelium is known to take 2–3 days in the rodent. Thus, in a longitudinal section along the crypt-to-surface axis, cells in various degrees of differentiation may be observed, providing a unique *in vivo* system in which to investigate differentiation-related glycosylation events.

In this review we will attempt to assimilate the data available from biochemical and cytochemical studies to present a picture of glycosylation reactions in the intestinal epithelium. Very few generalizations will be attempted given the

variability of the oligosaccharide structures of glycans in different segments of the gastrointestinal tract, as well as between animal species. Moreover, the very fascinating discipline of cancer-related changes in intestinal glycosylation will not be presented here (Boland and Kim, 1984; Bresalier *et al.*, 1985; Kim, 1989a,b). A review by Weiser and co-workers, focusing on intestinal cell membranes (but also discussing glycosylation) has been published in this series (Weiser *et al.*, 1986).

II. Overview of Glycosylation

A brief overview of what is known concerning glycosylation reactions is in order for the understanding of material presented in the rest of this paper. It is not in the realm of this review to present in great detail a treatise on glycosylation reactions in general. Interested readers may consult several excellent papers on this subject published in the last decade (Hanover and Lennarz, 1981; Hubbard and Ivatt, 1981; Kornfeld and Kornfeld, 1985; Hirschberg and Snider, 1987; Roth, 1987a). Most of the work investigating glycosylation has focused on the glycosylation of proteins; not as much is known concerning the glycosylation of lipids. For this reason, the vast majority of this article will focus on glycosylation of intestinal proteins, with only infrequent reference to glycolipids.

Glycoproteins can be conveniently divided into two main classes based on the nature of the covalent linkage between the amino acid in a peptide and the sugar residue of an oligosaccharide. One class of glycoproteins are characterized by oligosaccharide chains linked *N*-glycosidically from the sugar *N*-acetylglucosamine to the amide nitrogen of asparagine in the peptide (Fig. 4). A certain restriction seems to be placed on the asparagine residue to be glycosylated; it must be part of the sequence -Asn-X-Ser/Thr (where X can be any amino acid except proline or aspartic acid). Interestingly, even when asparagine is found in the correct sequence it is not always glycosylated, suggesting that accessibility of the sequence may also be a factor. The asparagine-linked (*N*-linked) oligosaccharides can further be divided into three subclasses depending upon the extent of trimming and elongation reactions: (1) high mannose-type oligosaccharides which contain only the sugars mannose and *N*-acetylglucosamine (Fig. 4C); (2) complex-type oligosaccharides which contain the sugars galactose, fucose, and sialic acid in addition to mannose and *N*-acetylglucosamine (Fig. 4B); and (3) hybrid-type oligosaccharides which contain both high mannose- and complex-type units (Fig. 4D). Although the three subclasses of *N*-linked oligosaccharides display a wide variety of structural conformations, they nevertheless all share the common core structure $\text{Man}\alpha 1-3(\text{Man}\alpha 1-6)\text{Man}\beta 1-4\text{GlcNAc}\beta 1-4\text{GlcNAc-Asn}^1$.

¹Abbreviations: Fuc, fucose; Gal, galactose; GalNAc, *N*-acetylgalactosamine; Glc, glucose; GlcNAc, *N*-acetylglucosamine; Man, mannose; Neu5Ac, neuraminic (*sialic*) acid; GDP-Man, guanosine 5'-diphosphate mannose; UDP-Gal, uridine 5'-diphosphate galactose; UDP-GlcNAc, uridine 5'-diphosphate *N*-acetylglucosamine.

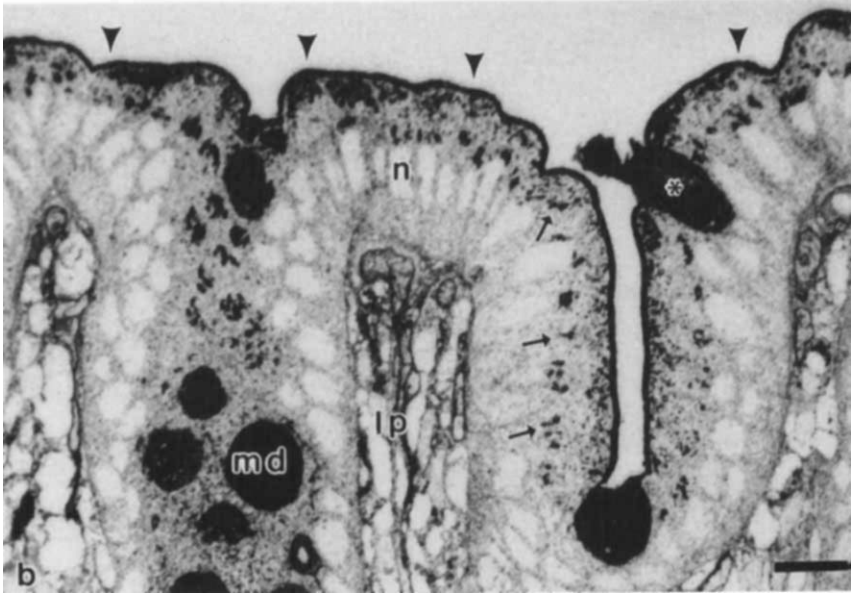
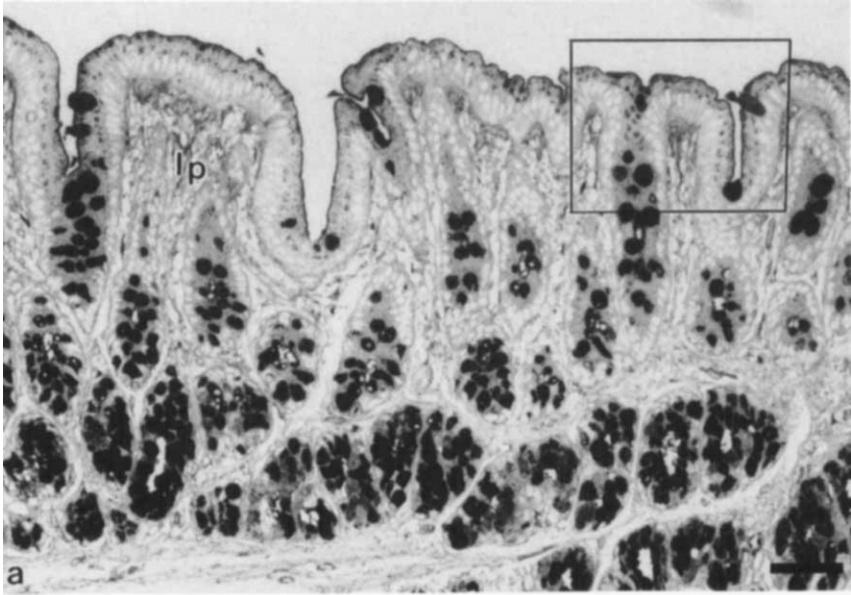

The second major class of glycoproteins are the so-called O- or mucin-type glycoproteins and comprise, among others, oligosaccharides attached via an O-glycosidic linkage from the sugar *N*-acetylgalactosamine to the hydroxyl group of the amino acids serine or threonine in the peptide (Fig. 5).

A third, and novel type of glycoprotein has recently been described in which *N*-acetylglucosamine is O-glycosidically attached to the peptide (Torres and Hart, 1984). This appears to be a most interesting type of glycoprotein since its synthesis most likely occurs outside of the normal cellular glycosylation pathway. Detailing this type of glycoprotein is beyond the scope of this review; however, this subject has recently been discussed by Hart and co-workers (Hart *et al.*, 1988, 1989).

A. ASSEMBLY OF N-GLYCOSIDICALLY LINKED OLIGOSACCHARIDES

The mechanisms of N-linked glycosylation reactions have been worked out in great detail (Kornfeld and Kornfeld, 1985; Roth, 1987a) and will only be briefly reviewed here. The classical reactions themselves are restricted to two intracellular compartments, the rough endoplasmic reticulum and the Golgi apparatus. The assembly of N-glycosidically linked oligosaccharide chains follows a unique pathway involving a lipid-linked intermediate. The lipid employed is dolichol phosphate, to which sugars are added in a stepwise manner, with the first seven sugars (two *N*-acetylglucosamine and five mannose residues) derived from the nucleotide sugars UDP-GlcNAc and GDP-Man, while the next seven sugars are donated from the lipid intermediates Dolichol-P-Man and Dolichol-P-Glc (Hirschberg and Snider, 1987). The resulting lipid-linked oligosaccharide consists of the structure $\text{Glc}_3\text{Man}_9\text{GlcNAc}_2\text{-P-P-Dolichol}$ (Fig. 4A), and is found in the lumen of the rough endoplasmic reticulum. Glycosylation of a growing peptide chain occurs via the *en bloc* transfer of the oligosaccharide chain from the lipid to an asparagine residue as the peptide is sequestered into the lumen of the rough endoplasmic reticulum. Processing of the oligosaccharide chain seems to begin immediately after its transfer to the peptide. The

FIG. 3. Light micrographs of semithin sections (1 μm) from rat proximal colon illustrating the basic organization of the intestinal mucosa. (a) The mucosa of the large intestine is composed of the surface epithelium lining the intestinal lumen, and the goblet cell-rich crypt region. Beneath the basement membrane of the surface epithelial cells is the lamina propria (lp). (b) Higher magnification of the boxed region from (a), demonstrating the organization of the surface epithelium. The section had been incubated with the *Limax flavus* lectin (specific for sialic acid residues), followed by fetuin-gold complex and silver amplification. All structures containing sialic acid therefore appear black in these photos. Note the intense staining of goblet cell mucus (md), brush border (arrowheads), Golgi apparatus (arrows), and cells in the lamina propria. In contrast, note the lack of nuclear staining (n). A goblet cell in the process of releasing mucus is denoted by an asterisk. $\times 160$ (a); $\times 725$ (b). Bars = 100 μm (a) and 13 μm (b). (b) (Reproduced with permission from Taatjes and Roth, 1988.)

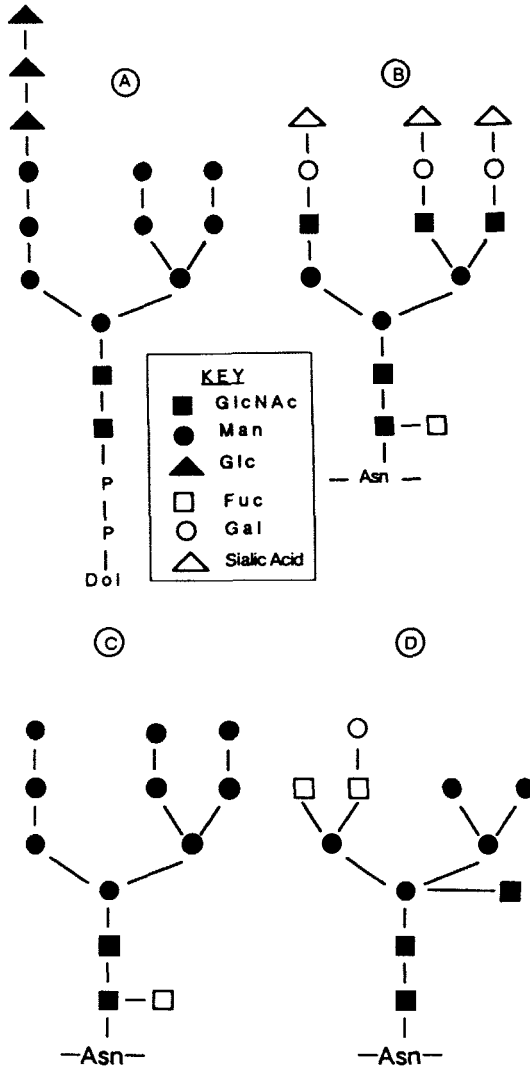

FIG. 4. Schematic representation of typical N-glycosidically linked oligosaccharides. (A) lipid-linked oligosaccharide precursor; (B) complex-type oligosaccharide; (C) high mannose-type oligosaccharide; and (D) hybrid-type oligosaccharide. See Section II for details.

extent of processing is dictated by whether the oligosaccharide chain on the glycoprotein is destined to become a high mannose- or complex-type. In the case of the high mannose-type, processing merely involves the removal of the three glucose residues, as well as perhaps a few mannose residues. In contrast, the pro-

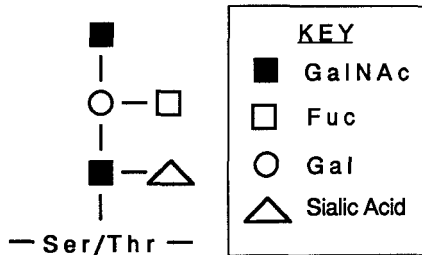

FIG. 5. Schematic representation of typical O-glycosidically linked oligosaccharide. See Section II for details.

cessing of complex-type oligosaccharides is more extensive and entails the removal of the three glucose residues and all but three of the mannose residues. These trimming events are carried out by the enzymes glucosidase I, glucosidase II, and ER mannosidases (Kornfeld and Kornfeld, 1985; Moremen and Touster, 1988). Following these trimming reactions, the glycoprotein is transported via vesicles to the Golgi apparatus where further mannose residues are removed (Moremen and Touster, 1988). Complex-type oligosaccharides are then completed in the Golgi apparatus by the addition of *N*-acetylglucosamine and the terminal sugars galactose, fucose, and sialic acid.

B. ASSEMBLY OF O-GLYCOSIDICALLY LINKED OLIGOSACCHARIDES

In contrast to the abundant information available concerning the synthesis of asparagine-linked oligosaccharides, less is known regarding the steps involved in the synthesis of O-glycosidically linked oligosaccharides. The synthesis of the oligosaccharide chain seems to be a late posttranslational event, appears to occur by a sequence of classical glycosyl transfer reactions, and does not involve an oligosaccharide-lipid intermediate (Hanover and Lennarz, 1981). The initial event consists of the transfer of *N*-acetylgalactosamine from UDP-GalNAc to serine or threonine in a polypeptide. There seems to be no requirement for a specific amino acid sequence surrounding the serine or threonine, as is necessary for the asparagine in N-glycosidically linked oligosaccharides. However, O-glycosyl residues are often clustered in regions rich in the amino acid proline, suggesting that a possible signal required for O-glycosylation is contained in the secondary or tertiary structure of the polypeptide chain (Hanover and Lennarz, 1981).

The precise cellular location of the onset of O-glycosylation has been difficult to ascertain. Depending upon the methodology employed, various investigators have implicated the rough endoplasmic reticulum (Strous, 1979) or the Golgi apparatus (Hagopian *et al.*, 1968; Kim *et al.*, 1971; Hanover *et al.*, 1980;

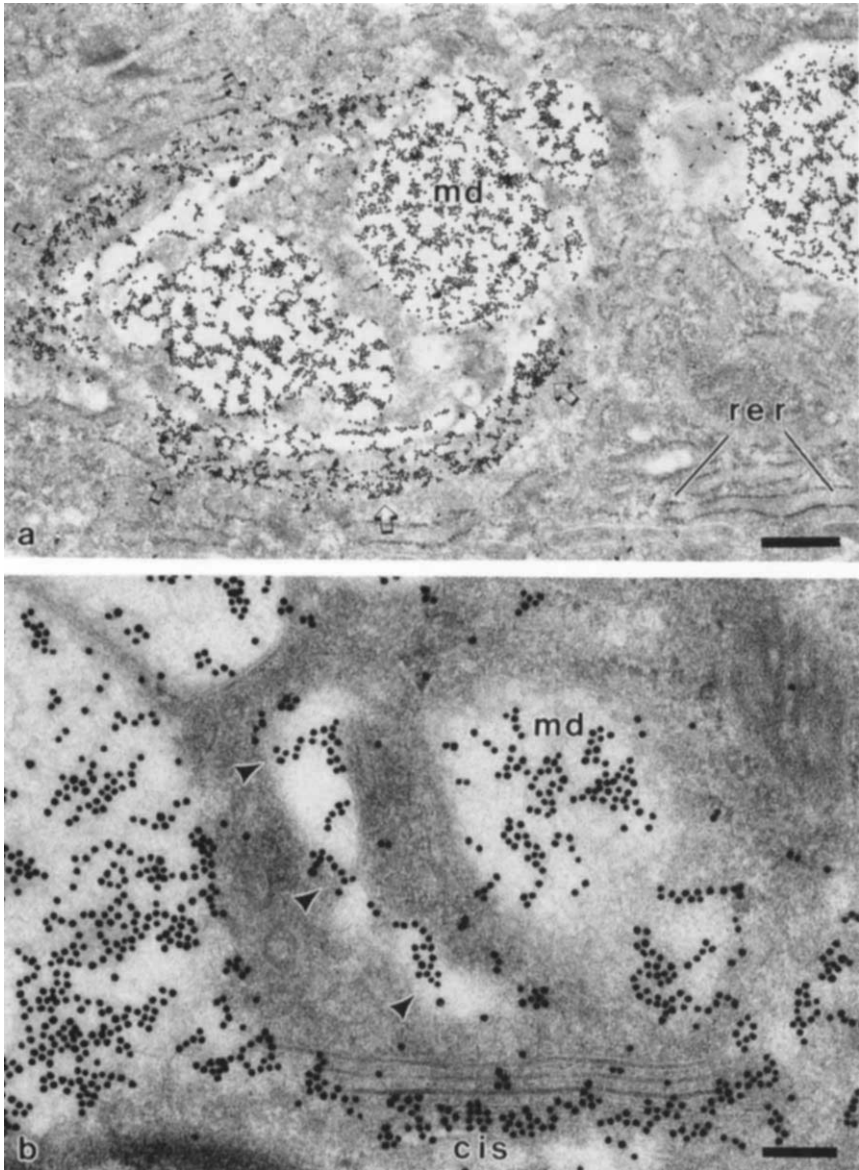

FIG. 6. Demonstration of *Helix pomatia* lectin-gold binding sites in sections from chick duodenum. Gold particle label is detectable in goblet cell mucus (md) and Golgi apparatus (arrows), but not in the rough endoplasmic reticulum (rer). At higher magnification (b), label in the Golgi apparatus is seen to be restricted to cis and trans (arrowheads) regions. X 5,500 (a); X 18,000 (b). Bars = 1.8 μ m (a) and 0.6 μ m (b). (Reproduced from the *J. Cell Biol.*, 1984, **98**, 399-406 by permission of the Rockefeller University Press.)

Roth, 1984; Deschuyteneer *et al.*, 1988; Tooze *et al.*, 1988) as the site of addition of *N*-acetylgalactosamine to the peptide chain. These conflicting results are most probably due to the different methodologies employed, or to cell type variability in glycosylation reactions (Section IV,B,2). The majority of the evidence, though, points to the Golgi apparatus (or a pre-Golgi apparatus compartment; see below) as the site of initiation of O-glycosylation. Elhammer and Kornfeld (1984) investigated the subcellular distribution of the initiating polypeptide : *N*-acetylgalactosaminyltransferase as well as the subsequently acting UDP-Gal : GalNAc- β -1,3 galactosyltransferase by fractionating the total microsomal membranes of mouse lymphoma BW5147 cells on linear sucrose gradients. They found that the two transferases were present in membranes of different densities. The galactosyltransferase codistributed with the "classical" galactosyltransferase involved in asparagine-linked glycosylation and was shown to reside in trans-Golgi apparatus cisternae of HeLa cells (Roth and Berger, 1982), whereas the polypeptide : *N*-acetylgalactosaminyltransferase distributed in a fraction intermediate between those containing galactosyltransferase activity and glucosidases I and II, the latter indicative of the endoplasmic reticulum (Lucocq *et al.*, 1986). These results were interpreted to suggest that the polypeptide : *N*-acetylgalactosaminyltransferase most likely was derived from membranes representative of the cis-Golgi apparatus, and was contained in a separate Golgi compartment from the galactosyltransferase.

In a carefully controlled complimentary biochemical approach, Abeijon and Hirschberg (1987) reported that in rat liver the polypeptide : *N*-acetylgalactosaminyltransferase activity (using apomucin as an exogenous acceptor) was highly enriched in membranes derived from the Golgi apparatus compared to those derived from the rough and smooth endoplasmic reticulum. Moreover, they found that vesicles prepared from the Golgi apparatus were able to translocate UDP-GalNAc into their lumen in an *in vitro* assay, at rates 4–6-fold higher than those from rough and smooth endoplasmic reticulum. These results demonstrated that at least in rat liver, all the cellular machinery necessary for the initiation of O-glycosylation was located within the Golgi apparatus.

An independent cytochemical investigation has also implicated the cis-Golgi apparatus as the site for the onset of O-glycosylation. Roth (1984) used a *Helix pomatia* lectin-gold complex in a postembedding study as a probe for terminal nonreducing *N*-acetylgalactosamine residues. In goblet cells of chick and rat intestine he found label in the cis and trans regions of the Golgi apparatus, but not in the endoplasmic reticulum (Figs. 6 and 7). He interpreted these findings to indicate that the initial transfer of *N*-acetylgalactosamine to the peptide occurs in the cis region of the Golgi apparatus, while the staining present in the trans region of the Golgi apparatus was representative of terminal *N*-acetylgalactosamine residues added on to the oligosaccharide chain. These results were corroborated and expanded upon by Deschuyteneer *et al.*, (1988). They used

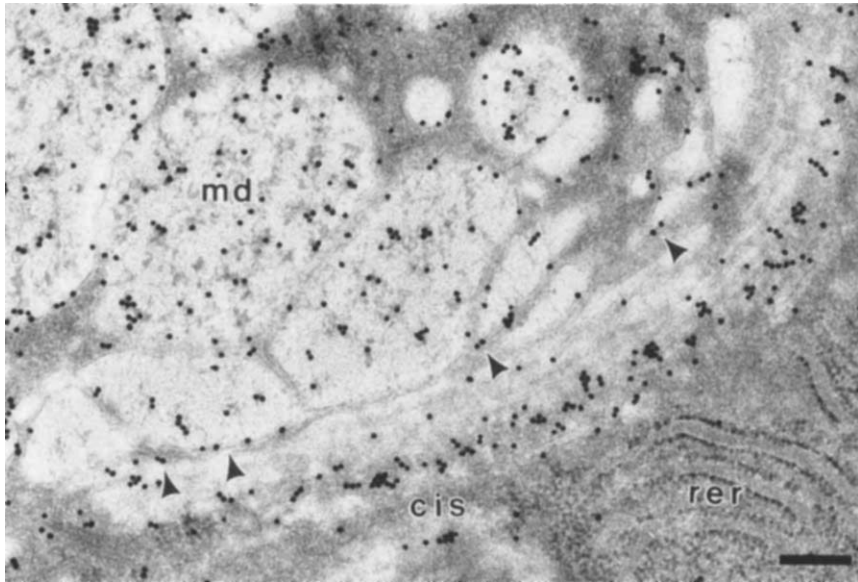

FIG. 7. Demonstration of *H. pomatia* lectin-gold binding sites in ultrathin section from rat colon. Gold particle label is found over cis-cisternae and dilated trans-cisternae (arrowheads) of goblet cell Golgi apparatus, as well as in mucus droplets (md). Note lack of staining over cisternae of rough endoplasmic reticulum (rer). X 11,500. Bar = 0.9 μ m. (Adapted from the *J. Cell Biol.*, 1984, **98**, 399-406 by permission of the Rockefeller University Press.)

immuno- and cytochemical means to investigate the site of addition of *N*-acetyl-galactosamine to the peptide chain of porcine submaxillary gland mucin. Employing an antibody which recognized only the deglycosylated form of mucin (apomucin), they found that immunoreactivity was localized throughout the rough endoplasmic reticulum (including the nuclear envelope) of mucous cells. In contrast, staining with a *H. pomatia* lectin-gold complex was found in the Golgi apparatus and mucus droplets, but not in the rough endoplasmic reticulum, confirming the results obtained by Roth (1984) for intestinal goblet cells. Interestingly, by treating thin sections with a cocktail of glycosidases, Deschuyteneer *et al.*, (1988) were able to detect immunoreactivity with the antibody raised against apomucin in the cis-cisternae of the mucous cell Golgi apparatus. These results provided very strong further support for the contention that the onset of O-glycosylation is a posttranslational event occurring most likely in cis-cisternae of the Golgi apparatus.

Very recently, a third compartment has been implicated as the site of the onset of O-glycosylation. Tooze and co-workers (1988) investigated steps in

the O-glycosylation of the E1 glycoprotein of coronavirus MHV-A59 using a combination of pulse-labeling and morphological techniques. They found that *N*-acetylgalactosamine was added to the E1 protein about 10 min after synthesis, followed about 10 min later by the addition of galactose and sialic acid, producing the mature oligosaccharide. They then took advantage of temperature-sensitive steps in the exocytic transport system of virus release (Saraste and Kuismanen, 1984) to block the movement of the glycosylated E1 protein out of different compartments. Interestingly, they were able to identify a smooth-membraned compartment situated between the endoplasmic reticulum and the cis-Golgi apparatus where the E1 glycoprotein was found to already possess *N*-acetylgalactosamine, but not galactose or sialic acid. They interpreted these results to indicate that the site of addition of the core *N*-acetylgalactosamine is this smooth membrane compartment, which most likely represents a budding compartment situated between transitional elements of the rough endoplasmic reticulum and the cis side of the Golgi apparatus. However, it should be borne in mind that these results were obtained from virally infected cells, which may or may not behave as normal cells with respect to glycosylation reactions. Nevertheless, in light of these findings, the results of Elhammer and Kornfeld (1984) discussed above could also be interpreted to suggest that the polypeptide : *N*-acetylgalactosaminyltransferase is housed within this pre-Golgi apparatus budding compartment, rather than within cis-Golgi apparatus cisternae. It seems likely, though, that the definitive answer defining where the onset of O-linked glycosylation occurs awaits the immunocytochemical localization of the polypeptide : *N*-acetylgalactosaminyltransferase. Regardless, subsequent O-linked glycosylation reactions are known to occur in the Golgi apparatus.

III. Methods Employed to Investigate Cellular Glycosylation Reactions in Intestine

Investigations into intestinal glycosylation have mainly drawn upon biochemical and morphological techniques for the demonstration of enzymes (glycosyltransferases) involved in glycosylation reactions, as well as the carbohydrate products resulting from the enzymatic action. These techniques are not specific to the study of intestinal tissues, but rather have been used to study glycosylation in general. The unique application of these methods to intestinal tissues stems mainly from the following three areas: (1) separating activities from crypt and villus portions of the small intestine; (2) separating activities from Golgi apparatus membranes and plasma membranes; and (3) investigating glycosylation changes in different intestinal regions.

A. BIOCHEMICAL METHODS

Two main biochemical tacks have been followed in the investigation of intestinal glycosylation. The first was to assay for the activity of specific glycosyltransferases, followed by subsequent purification. These assays were usually employed with the goal of measuring and comparing activities of various glycosyltransferases in the different intestinal segments, as well as crypt versus villus. Moreover, such methods were also extensively used to compare changes in different glycosyltransferase activities during development (Section IV,A,2). The main drawbacks of this method were the possible contamination of cellular fragments which could lead to erroneous conclusions, as well as the inability to identify which cells in the mixture actually contained the glycosyltransferase of interest (Section IV,A,1). The second most popular method has been to measure the incorporation of radiolabeled sugars into glycoproteins and glycolipids and following their transport to final destinations (Section IV,A,3).

B. MORPHOLOGICAL METHODS

As noted in the Introduction, classical morphological and cytochemical methods have been extensively applied to studies of intestinal glycosylation. These studies will not be mentioned again here so that we may focus on more recent types of cytochemical investigations. However, it should be borne in mind that although we now have available more sensitive and specific probes, as well as refined cytochemical techniques, the results obtained have dramatically supported the original conclusions drawn from the earlier studies.

Investigations employing lectins have proven to be of particular importance for the study of intestinal glycosylation (Etzler and Branstrator, 1974). Lectins are carbohydrate-binding proteins of nonimmune origin that agglutinate cells and precipitate glycoconjugates (Goldstein and Poretz, 1986). When coupled to an appropriate marker (Fig. 8) they can be used to demonstrate the cellular occurrence and distribution of specific sugar residues (Roth, 1978, 1987b). In intestinal studies they have been used to investigate Golgi apparatus glycosylation events, to determine the pattern of sugar residue expression at the plasma membrane of epithelial cells along the intestinal tract, and to monitor changes in the glycosylation pattern of epithelial cells during development and neoplastic transformation. For convenience, a list of lectins (with their saccharide specificities) mentioned in this article is presented in Table I.

A major advance for the field of glycosylation investigation in general (however, also applicable to intestinal studies; Sections IV,B,2; IV,C) was the development of sensitive, yet routine methods for electron microscopic immunocytochemistry. The first was the introduction of colloidal gold particles as an electron dense marker for immunocytochemistry (Faulk and Taylor, 1971). This

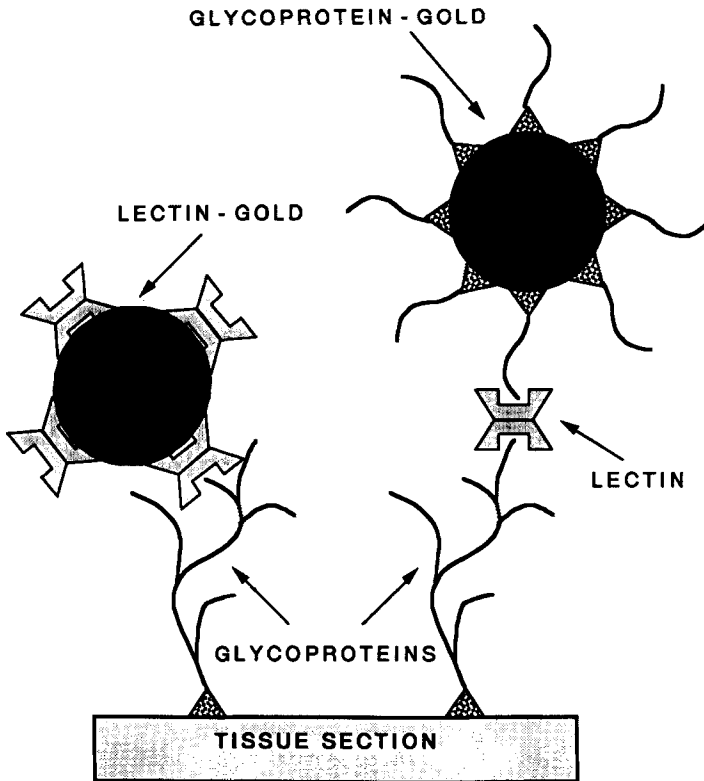

FIG. 8. Schematic representation of lectin-gold techniques for the detection of sugar residues on thin sections from tissues embedded in Lowicryl K4M. Lectins can be applied directly complexed with particles of colloidal gold (left side of figure), or in a two-step cytochemical affinity technique employing an unlabeled lectin followed by a glycoprotein-gold complex (right side of figure). A detailed description of these procedures can be found in Roth *et al.* (1988a) and Roth (1989).

was followed by the introduction of the protein A-gold technique (Roth *et al.*, 1978) for the postembedding localization of antigenic sites (Fig. 9). The virtues of this method have been detailed in many reviews (Roth, 1983a, 1986, 1989; Bendayan, 1984) and will not be enumerated here. It suffices to say that the protein A-gold technique in conjunction with the introduction of the low temperature embedding methods employing Lowicryl K4M (Carlemalm *et al.*, 1982) provided the means necessary for the precise immunolocalization of the relatively scarce glycosyltransferases. Of course, of equal importance was the production and availability of highly specific anti-glycosyltransferase antibodies (Roth and Berger, 1982; Weinstein *et al.*, 1982; Shaper *et al.*, 1985; Ulrich *et al.*, 1986). The combination of these innovations provided immediate dividends

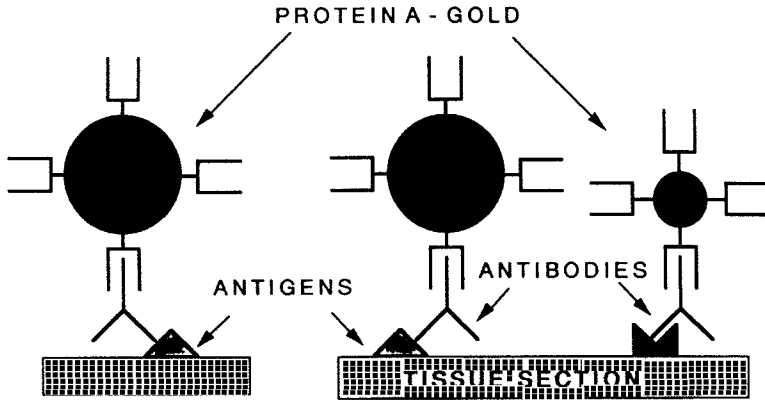

FIG. 9. Schematic representation of the protein A-gold technique for antigen localization on thin sections from tissues embedded in Lowicryl K4M. This is a typical two-step technique in which sections are first incubated with an antibody, followed by protein A-gold complex which binds to the Fc portion of the antibody. As illustrated on the right side of the figure, multiple antigens can be detected on the same section by employing colloidal gold particles of different sizes. Details of this technique can be found in Roth *et al.* (1978) and Roth (1983a, 1989).

TABLE I
SACCHARIDE-BINDING SPECIFICITIES OF VARIOUS LECTINS

Lectin	Common name	Abbreviation	Nominal specificity ^a
<i>Canavalia ensiformis</i>	Jack bean	Con A	α Man > α Glc > GlcNAc
<i>Lens culinaris</i>	Lentil	LCL	α Man > α Glc > GlcNAc
<i>Pisum sativum</i>	Pea	PSL	α Man > α Glc = GlcNAc
<i>Triticum vulgare</i>	Wheat germ	WGA	GlcNAc (β 1,4GlcNAc) ₁₋₂ > β GlcNAc > Neu5Ac
<i>Dolichos biflorus</i>	Horse gram	DBL	GalNAc α 1,3GalNAc >> α GalNAc
<i>Helix pomatia</i>	Edible snail	HPL	GalNAc α 1,3GalNAc > α GalNAc
<i>Glycine max</i>	Soybean	SBL	α GalNAc = β GalNAc
<i>Griffonia simplicifolia</i> I-B ₄	-	GSL I	α Gal >> α GalNAc
<i>Arachis hypogaea</i>	Peanut	PNL	Gal β 1,3GalNAc > α and β Gal
<i>Ricinus communis</i> I	Castor bean	RCL I	β Gal > α Gal >> GalNAc
<i>Ricinus communis</i> II	"	RCL II	β and α Gal > GalNAc
<i>Datura stramonium</i>	Thorn apple	DSL	Gal β 1,4GlcNAc = GlcNAc (β 1,4GlcNAc) ₁₋₃
<i>Lotus tetragonolobus</i>	Asparagus pea	LTL	α -L-Fuc
<i>Ulex europaeus</i>	Gorse seed	UEL I	α -L-Fuc
<i>Limax flavus</i>	Slug	LFL	α Neu5Ac > α Neu5Gc
<i>Sambucus nigra</i> L.	Elderberry	SNL I	Neu5Ac α 2,6Gal/GalNAc
<i>Maackia amurensis</i>	-	MAL	Neu5Ac α 2,3Gal

^aAbbreviations: Man, mannose; Glc, glucose; GlcNAc, *N*-acetylglucosamine; GalNAc, *N*-acetylgalactosamine; Gal, galactose; Fuc, fucose; Neu5Ac, sialic acid.

with the publication of the first immunocytochemical localization of a glycosyltransferase at the electron microscopic level (Roth and Berger, 1982). This paper provided a key piece of evidence which led to the subcompartmentation model of the Golgi apparatus, which will be discussed in detail in Section IV,B,1b. At the same time, the opportunity had now arisen to explore the subcellular distribution of glycosyltransferases at the electron microscopic level in intestinal epithelial cells.

IV. Distribution of Intestinal Glycosyltransferases and Their Saccharide Products

A. STUDIES ON WHOLE TISSUE

1. Measurement of Glycosyltransferase Activities in Adult Animals

As mentioned earlier, many of the studies concerning glycosyltransferases in intestinal cells sought to compare activities in the crypt with those in the villus, or to compare glycosyltransferases among various segments of the intestinal tract. Weiser (1973a,b) compared the glycosyltransferase activity of mature cells in the villus with immature cells of the crypt by measuring the incorporation of radiolabeled monosaccharides into surface membrane glycoproteins, and using this as a measure of the corresponding glycosyltransferase activity. He employed a separation method based on citrate and EDTA to dissociate cells, resulting in epithelial cell fractions which defined a gradient of cells from villus tips to crypts. His results demonstrated that the levels of *N*-acetylgalactosaminyltransferase, galactosyltransferase, and fucosyltransferase were approximately 10-fold greater on crypt as compared to villus cells, whereas sialyltransferase activity was higher on villus cells. In a subsequent study, however, Weiser and co-workers (1978) not only separated crypt from villus cells, but also prepared membrane fractions, and reported that the basolateral plasma membrane of villus cells was rich in galactosyltransferase activity. This discrepancy with their previous results (Weiser, 1973a,b) was explained as resulting from the presence of glycosidases on the microvilli of intact villus cells in the earlier study which had interfered with the detection of glycosyltransferases on the lateral plasma membrane. However, an alternative explanation was proposed by Lau and Carlson (1981). They found that nucleotide pyrophosphatase, an enzyme that interferes with glycosyltransferase assays, is particularly enriched in intestinal mucosa (especially at the villus tips). By assuring inactivation of this enzyme, they determined that the activity of two galactosyltransferases (one acting on asparagine-linked and the other acting on O-linked oligosaccharides) displayed essentially identical activities on both crypt and villus cells. They

advocated exercising caution when interpreting the measurement of intestinal glycosyltransferase activities without recognizing the potential influence of nucleotide pyrophosphatase.

In subsequent studies, Weiser's group (Weiser *et al.*, 1987; Wilson *et al.*, 1987) took precautions against nucleotide pyrophosphatase activity and analyzed the rat intestinal distribution of two different galactosyltransferases; one acting on N-linked oligosaccharides and the other acting on O-linked (mucin-type) oligosaccharides (this enzyme may be identical to that investigated by Lau and Carlson mentioned above). They were still able to detect both crypt : villus differences as well as differences among intestinal segments for both enzymes. The galactosyltransferase acting on O-linked oligosaccharides showed increased activity in the duodenum and distal ileum of the small intestine, and the cecum and proximal colon of the large intestine (Wilson *et al.*, 1987). These areas of increased activity corresponded to areas of increased mucus production. Moreover, within the duodenum this galactosyltransferase showed a moderately increased activity in cells from the crypt region as compared to those of the villus; however, no such difference was detectable in the jejunum or ileum. The galactosyltransferase acting on N-linked oligosaccharides displayed highest activities in the terminal ileum, cecum, and proximal colon, with lesser amounts detected in the jejunum and duodenum (Weiser *et al.*, 1987). Although they could not demonstrate a difference in total homogenate galactosyltransferase activity between crypt and villus cells, they found that assays for cell surface galactosyltransferase revealed an elevation in the crypts (Section IV,C).

Kim and co-workers (1975) devised a planar sectioning technique utilizing a mounted razor blade to cut frozen sections for the separation of crypt from villus cells. Upon homogenization the sections were assayed for glycosyltransferase activity. The results showed that sialyltransferase activity was enriched in crypt cells, whereas galactosyltransferase activity was approximately equal in both regions (Kim *et al.*, 1975). These results are in contrast to those from Weiser's group mentioned above. The discrepancy may have arisen from the different methodologies employed by the two groups for the separation of cell populations or from glycosyltransferase activity variation among intestinal sections. Nevertheless, both separation techniques suffer from the questionable purity of the fractions. Indeed, the importance of the purity of intestinal fractions cannot be overstated, since elements other than intestinal epithelial cells have recently been shown to be the major, if not the only source for sialyltransferases in rat small intestine (Paulson *et al.*, 1989).

Glycosyltransferase activities were also shown to vary from the proximal to the distal regions of the rat small intestine (Morita *et al.*, 1986). Specifically, activities for two galactosyltransferases (acting on N- and O-linked oligosaccharides), two sialyltransferases (acting on N- and O-linked oligosaccharides), fucosyltransferase and *N*-acetylgalactosaminyltransferase were consistently found

to be higher in distal regions of the small intestine compared with proximal regions. These results were corroborated by the carbohydrate analysis of brush border membranes in proximal and distal small intestine. Interestingly, both sialyltransferase enzymes displayed the lowest activity of all the glycosyltransferases assayed. In an immunocytochemical investigation (Section IV,C) we found that the distribution of the $\alpha 2,6$ -sialyltransferase was regionalized within the rat intestine (Taatjes *et al.*, 1988a). Although abundant staining was detectable in all regions of the large intestine, no labeling was detectable in any portion of the small intestine from the same animals. These results were corroborated by direct measurement of enzymatic activity for the $\alpha 2,6$ - and $\alpha 2,3$ -sialyltransferases. In this case, the activity of these two sialyltransferases (both acting on N-linked oligosaccharides) was undetectable in rat small intestine. These results would appear to conflict with those of Morita *et al.* (1986) mentioned above, as well as those of Van Halbeek *et al.* (1983) who reported the presence of sialic acid $\alpha 2,3$ linked to galactose in mucin glycoproteins from rat small intestine. The apparent discrepancy may be explained in part by the fact that we examined sialyltransferase activity only for the mucosal surface of the intestine scraped from the intestinal wall. Indeed, in a subsequent investigation, Paulson *et al.* (1989) found that homogenates of the intestinal wall itself contain substantial levels of this sialyltransferase in the small intestine. Moreover, in contrast to the results of Morita *et al.* (1986) they found that the activity for a sialyltransferase (adding sialic acid in an $\alpha 2,3$ position to galactose in O-linked oligosaccharides) actually decreased in the mucosa from proximal to distal small intestine. Ironically, no activity was detectable in the ileal mucosa, whereas substantial activity was measurable in the ileum wall. Thus, results obtained from intestinal homogenates or segments are not directly comparable. This also indicates that these sialyltransferase enzymes are differentially expressed within different regions of the small intestine, each having specialized functions, yet identical cell types. These results have recently been further supported by *in situ* lectin-binding studies (Section IV,A,6).

The situation is further complicated by the acceptor substrates used for the measurement of glycosyltransferase activity. For instance, according to the "one-enzyme one-linkage" hypothesis (Hagopian and Eylar, 1968) at least a dozen different sialyltransferases must exist in order to form the known linkages of sialic acid to penultimate sugars. Thus, fetuin, which is quite often employed as an acceptor substrate for sialyltransferase activity, contains both N- and O-linked carbohydrate groups which are acceptors for at least four different sialyltransferases (Kim *et al.*, 1975; Weinstein *et al.*, 1982; Green *et al.*, 1988). This may explain in part the sometimes variable results reported using different techniques with respect to glycosyltransferase distribution within the intestine. Earlier studies demonstrating glycosyltransferase activity based upon known acceptor substrates may have actually been measuring the activity of several

different enzymes. However, due to antibody specificity, immunological-based techniques are assaying for the presence of one highly linkage-specific glycosyltransferase. Therefore, these limitations should be borne in mind when interpreting results from different investigators employing different techniques.

Much less information is available concerning the glycosyltransferase activity in the large intestine. Freeman *et al.* (1978) have demonstrated that in adult rat large intestine both galactosyltransferase and sialyltransferase activities were significantly greater in proximal than in distal colonic mucosa. We have reported (Taatzjes *et al.*, 1988a) enzymatic activity for two sialyltransferases acting on asparagine-linked oligosaccharides in mucosal scrapings from rat large intestine (Section IV,C; Table IV).

2. Measurement of Glycosyltransferase Activity during Development

The activity of several glycosyltransferases has been found to vary during postnatal development in both rat small and large intestine. Sialyltransferase activity was present in increased levels during the suckling period, and decreased 5-fold during the subsequent weaning and adult periods (Chu and Walker, 1986). On the other hand, fucosyltransferase activity was very low during suckling phase, rapidly increased during weaning, and reached adult levels by 5 weeks of age (Chu and Walker, 1986).

The activities of two galactosyltransferases, the UDP-Gal : GlcNAc(β 1-4)-galactosyltransferase, and UDP-Gal : GalNAc(β 1-3)-galactosyltransferase have also been found to be under developmental regulation (Ozaki *et al.*, 1989). Both glycosyltransferases demonstrated a marked elevation in activity after the weaning period and into adulthood in all regions of the rat small intestine. All of these results considered together demonstrate that activities for galactosyltransferase, *N*-acetylgalactosaminyltransferase and fucosyltransferase all increase during postnatal development of rat small intestine. On the other hand, sialyltransferase activity declines during the same developmental period. These data correlate well with known changes in terminal glycosylation of microvillar proteins during postnatal development of rat small intestine (Sections IV,A,4 and 6).

The activity of galactosyltransferase has been measured in fetal and postnatal rat large intestine (LaMont and Ventola, 1978). The activity in fetal homogenates increased 4- to 7-fold between 18 and 22 days, the last 4 days of gestation. The enzyme activity then gradually increased postnatally, reaching adult levels by day 15. Determination of the autoradiographic incorporation of [3 H]galactose into fetal large intestine glycoconjugates correlated well with the increase in galactosyltransferase activity during this period (Rampal *et al.*, 1978). Interestingly, these autoradiographic studies revealed the selective incorporation of [3 H]galactose into goblet cells but not into absorptive cells. These results therefore suggest that the maturation of fetal rat large intestine during the

last 4 days of gestation is accompanied by the appearance of goblet cells and enhanced mucus synthesis.

3. Analysis of Sugar Content of Membrane Glycoproteins in Adult Animals

Two basic biochemical methods have traditionally been applied in order to determine the carbohydrate composition of intestinal membrane glycoproteins. The first method requires the administration of radiolabeled sugar precursors into the lumen of the intestine, followed by purification and analysis of the incorporation of the sugars into membrane glycoproteins. The second method employs the binding of labeled lectins to intestinal plasma membrane fractions.

In an early study, Kim and Perdomo (1974) traced the incorporation of [^{14}C]glucosamine into the membranes of intestinal cells. They prepared three membrane fractions, consisting of smooth, rough, and brush border membranes. They observed incorporation first into smooth membranes, followed after a lag period by entrance into rough and brush border fractions. Aside from the peculiar late entrance into a rough membrane fraction, these results trace the transit of [^{14}C]glucosamine-containing glycoconjugates from the Golgi apparatus to the brush border. A further purification to distinguish apical (brush border) membranes from basolateral was not attempted.

Quaroni and co-workers (Quaroni *et al.*, 1980; Herscovics *et al.*, 1980) took these studies further by separating Golgi apparatus, apical, and basolateral membranes, both in crypt and villus cells. They measured the incorporation of L-[5,6- ^3H]fucose and D-[2- ^3H]mannose into intestinal membrane glycoproteins following an intraperitoneal injection of these radiolabeled sugars. The incorporation of mannose was roughly equal in crypt and villus cells, whereas fucose incorporation was elevated in the differentiated villus cells (Quaroni *et al.*, 1980). Fucosylated glycoproteins were originally detected in the Golgi apparatus and basolateral membranes, followed by redistribution into villus membranes after 3–4 hr. In contrast, most mannose-labeled glycoproteins remained in the Golgi and basolateral membrane fractions. They interpreted their results to indicate that fucosylated glycoproteins represent a special class of membrane components that appear with differentiation (absent in undifferentiated crypt cells) and are specifically localized to the luminal portion of the intestinal cell plasma membrane. In an accompanying paper, Herscovics *et al.* (1980) used similar techniques to demonstrate that high-mannose oligosaccharides were the precursors of complex oligosaccharides. Moreover, they provided evidence that luminal membranes of both crypt and villus cells were greatly enriched in complex oligosaccharides as compared with basolateral plasma membranes, but no qualitative changes were found to occur during cellular differentiation. Thus, their results suggested that intestinal epithelial cells were polarized with respect to plasma membrane glycoconjugate oligosaccharide composition (Section IV,A,5).

The second biochemical method, utilizing lectin binding to isolated cell plasma membranes, is a more recent innovation, and has found widespread use for the comparison of membrane glycoproteins among intestinal segments as well as during maturation. Kim and co-workers (Morita *et al.*, 1986) examined the reactivity of brush border membrane components with lectins, and the binding of brush border membrane-associated enzymes to *Ricinus communis* lectin I (RCL I) and wheat germ agglutinin (WGA) in segments from the proximal and distal small intestine. In addition they analyzed the carbohydrate composition of the brush border membranes. Their results indicated that although brush border membrane glycoproteins from distal portions of the small intestine contained more complete oligosaccharide side chains, the glycoprotein profile on SDS gels was less complex than in proximal small intestine. Specifically, more WGA and succinylated-WGA-binding glycoproteins were present on brush border membranes from proximal compared to distal segments. However, the binding of RCL I to brush border membranes was two times higher in the distal as compared to proximal small intestine. Overall sugar content was higher in distal small intestine brush border membranes, reflected mainly by elevated galactose and sialic acid content. The content of *N*-acetylglucosamine appeared equal in the two intestinal segments. These results suggest that the carbohydrate content of brush border membranes changes with the progression of the gastrointestinal tract, with more distal regions of the small intestine containing more completed oligosaccharide chains.

4. Analysis of Sugar Content of Membrane Glycoproteins During Development

Similar biochemical methods to those just mentioned above have also been used extensively to investigate changes in the glycosylation pattern of microvillar proteins in postnatal intestine. Mahmood and Torres-Pinedo (1983) incubated microvillar membrane preparations from postnatal rats with radiolabeled lectins to determine the carbohydrate profile of membrane glycoconjugates. They found that the microvillus membrane of suckling rats (from birth to about 2 weeks of age) was rich in glycopeptides containing binding sites for peanut lectin (PNL) in sialyl-substituted form. During the weaning phase (14–21 days postnatal), the membranes lost about half of these binding sites, accompanied by decreased sialic acid content and increased content of glycopeptides containing unsubstituted binding sites for soybean lectin (SBL) and RCL I. Perhaps the most important result from this study was the finding that the sialic acid content of microvillar plasma membrane drastically decreases from the suckling to the weaning period. Indeed, in a subsequent paper (Torres-Pinedo and Mahmood, 1984) they found that this decrease in microvillar plasma membrane sialic acid content was accompanied by a dramatic rise in fucose content. They observed that the binding of ^{125}I -labeled WGA to neuraminidase-sensitive sites in the microvillar membrane decreased markedly from early suckling to weaning ages.

At the same time, the binding of ^{125}I -labeled *Ulex europaeus* lectin I (UEL I) to microvillar membranes showed an opposite increase from suckling to weaning periods. This developmentally related shift from sialylation to fucosylation was found for both glycoproteins and glycolipids of the microvillar membrane, suggesting that it is a general phenomenon for membrane constituents. They postulated that such a dramatic shift from a strongly acidic to a more neutral microvillar glycocalyx could relate to the physiological changes occurring in the intestine concomitant with development.

These studies were followed up by examining the carbohydrate profile of individual microvillar membrane proteins during postnatal development of the rat small intestine. Srivastava *et al.* (1987) found that the terminal glycosylation of several microvillar glycoproteins of >90,000 Da (most likely hydrolases) does not reach complete maturation until after weaning, although their content within the membrane has reached adult levels by this time. Moreover, several of these glycoproteins were fully sialylated during the suckling period, whereas addition of *N*-acetylgalactosamine and fucose continued well into the weaning period. Buller *et al.* (1990) took such investigations one step further by examining the glycosylation of a known glycoprotein, lactase-phlorizin hydrolase, during development of the rat small intestine. Lectin binding to the enzyme immunoprecipitated from microvillus membranes revealed the presence of both *N*- and *O*-linked oligosaccharide chains containing mannose and galactose, which did not vary throughout development. In contrast, the content of fucose and sialic acid was developmentally regulated; sialic acid was present at weaning and declined through adulthood, whereas fucose was not detectable until rats were 20 days of age. Thus, by examining a single enzyme, it was established that the core *N*- and *O*-linked oligosaccharide structures of this microvillar hydrolase remain constant during development, whereas alteration in terminal glycosylation occurs with a shift from sialic acid at suckling to fucose in adulthood. The above studies taken together show that a definite change in glycosylation occurs on specific microvillar membrane glycoproteins during the postnatal developmental period.

In a related study (Jaswal *et al.*, 1988), the content of sialic acid and fucose in enterocytes was measured in crypt and villus cells from suckling and adult animals. In suckling animals, no change was found in the sialic acid content of enterocytes during progression from crypt to villus. In contrast, the sialic acid content decreased precipitously from crypt to villus in adult animals. The fucose content of enterocytes from suckling animals was greater in the crypts than in the villus, whereas in adult animals fucose content was much greater in the villus.

5. Cytochemical Detection of Lectin Binding to Intestinal Cells in Situ

Much cytochemical data based upon lectin binding studies have contributed to the understanding of intestinal glycosylation patterns. In the absence of

glycosyltransferase enzymatic measurements, lectin-binding sites can be taken as indicative of specific glycosyltransferase activity. The earliest studies used lectins conjugated to fluorescent dyes in a direct labeling technique, usually on frozen or paraffin sections. Such investigations demonstrated differences in lectin-binding patterns to intestinal epithelial cells in the various segments of the intestinal tract. For instance, Etzler and Branstrator (1974) examined the binding of FITC-conjugated lectins from *Dolichos biflorus* (DBL), *Lotus tetragonolobus* (LTL), *Ricinus communis* I, and *Triticum vulgare* (WGA) to the various regions from rat small intestine. They observed differences in the binding of the lectins to both the epithelial cell plasma membranes, as well as to the goblet cell mucus. With respect to plasma membrane staining, LTL, RCL I, and WGA bound to the microvillar portion of the epithelial cells lining the crypts and villi in the proximal regions of the small intestine. This pattern of staining was altered along the first 15 cm of the small intestine, such that distal to this point the apical surfaces of only those epithelial cells in the crypts and at the base of the villi reacted with LTL and RCL I, while WGA stained the apical surfaces of cells lining the villi. In the distal small intestine, LTL, RCL I, and WGA stained the cell surfaces of only those epithelial cells at the base of the villi and in the crypts. DBL did not stain the epithelial cell surface in any portion of the small intestine. With respect to staining of the mucus content of goblet cells, WGA and DBL stained the goblet cells in proximal portions of the intestine, whereas in middle and distal regions all four lectins were found to stain goblet cell mucus. These results suggested that the content of complex carbohydrates in goblet cell mucus increases from proximal to distal regions of the small intestine.

In a preembedding peroxidase study, Ovtsharoff and Ichev (1984) showed that in rat small intestine (middle regions), the pea and soybean lectins stained the microvillar membrane from epithelial cells in the crypts and lower villus more intensely than those in the upper villus and lumen.

Essner *et al.* (1978) also used several lectins conjugated to FITC to investigate the lectin-binding pattern to cryostat sections from portions of the descending colon of the rat. Besides reactivity in goblet cell mucus and plasma membrane, they identified cytoplasmic staining which they attributed to the Golgi apparatus. Binding sites for the lectins from *Glycine max* (SBL) and *Dolichos biflorus* were observed in goblet cell mucus, apical and basolateral plasma membranes, and in the apical cytoplasm, indicating the presence of terminal nonreducing *N*-acetylgalactosaminyl residues at these sites. WGA, RCL I, UEL I, and concanavalin A (Con A) all stained the cytoplasm of epithelial cells, but did not, or only weakly, stain mucus droplets and plasma membranes.

Gorelick *et al.* (1982) examined lectin-binding patterns in the plasma membrane and goblet cell mucus of epithelial cells in the various regions of guinea pig large intestine. Staining of the brush border with the various rhodamine-labeled lectins tended to be heterogeneous across the regions of the large intestine.

In general, though, Con A, WGA, RCL II, and PNL stained the brush border of the right colon, whereas RCL I and SBL stained the transverse colon intensely. Limulin reacted with the brush border only in the left colon. Staining of the goblet cell mucus was even more variable. Gorelick *et al.* (1982) not only examined the lectin binding to the goblet cell mucus in the various regions of the large intestine, they also separated the intestinal segments according to crypt regions: basal, middle and apical. Again, the staining patterns varied not only among the large intestinal segments, but also within crypt region of individual segments. Noted exceptions were LTL and PNL which did not stain the goblet cell mucus in any area examined. Moreover, goblet cells in the transverse and left portions of the large intestine tended to react more intensely with the various lectins employed, suggesting a maturation of goblet cell mucus along the large intestine. The paper by Gorelick *et al.* (1982) also served to usher in the modern approach to investigating intestinal lectin-binding sites; namely, the postembedding application of colloidal gold-labeled lectins to ultrathin sections. They prepared a complex of colloidal gold particles with RCL II and applied this to sections from intestine embedded in Epon-Araldite. They were able to demonstrate binding of this complex to goblet cell mucus, apical plasma membrane, apical cytoplasmic vesicles, and Golgi apparatus. Since this time, numerous papers have been published utilizing both colloidal gold-labeled lectins and peroxidase-labeled lectins at the light and electron microscopic level to investigate intestinal glycosylation patterns. The main benefit of such studies has been the increase in resolution over fluorescence studies obtainable with these methods. Many of these studies were interested in investigating the role of the Golgi apparatus in glycosylation, and their results will be described in Section IV,B,3. In the current section we will detail the results of these studies as they relate to plasma membrane and mucous glycoconjugates.

Helix pomatia lectin (HPL) binding has been observed (Fig. 10) in the mucus and apical plasma membrane of chick duodenum (Roth, 1984), rat duodenum (Ellinger and Pavelka, 1985), and rat jejunum (Murata *et al.*, 1986). RCL I binding has been reported in the mucus and apical and basolateral plasma membranes of chick (Roth, 1983b) and rat duodenum (Ellinger and Pavelka, 1985), and the basolateral plasma membrane of rat proximal colon epithelial cells (Roth *et al.*, 1988a). Pavelka and Ellinger (1989b) have shown binding of *Erythrina cristagalli* lectin (ECL) to apical and basolateral plasma membranes and goblet cell mucus in rat duodenum, while Egea *et al.* (1989) have reported identical results by using *Datura stramonium* lectin (DSL). *Lotus tetragonolobus* lectin (LTL) binding to the apical plasma membrane and goblet cell mucus has been described in chick duodenum (Roth, 1983b), while UEL I binding to apical plasma membrane and goblet cell mucus has been reported for rat duodenum (Ellinger and Pavelka, 1988a). Binding of sialic acid-specific lectins has also been documented in intestinal cells. Roth *et al.* (1984) found binding of



the *Limax flavus* lectin (LFL) to the apical plasma membrane and goblet cell mucus in rat distal colon. Similar results were also found in rat proximal colon (Taatjes and Roth, 1988). Recently, staining with *Maackia amurensis* lectin (MAL) has been reported in the apical and basolateral plasma membranes and goblet cell mucus in pig colon (Sata *et al.*, 1989). Furthermore, we have recently observed staining with *Sambucus nigra* L. lectin (SNL I) complexed with colloidal gold particles (Taatjes *et al.*, 1988b) in mucus droplets, but not in the plasma membrane of rat jejunal epithelial cells (Taatjes and Roth, 1990; Section IV,A,6). The main message resulting from all of these studies is that lectins recognizing complex carbohydrate structures bind to plasma membranes and goblet cell mucus in both small and large intestine from various species.

6. *Cytochemical Detection of Lectin Binding to Intestinal Cells in Situ During Development and Differentiation*

As described in Section IV,A,2, the activities of several glycosyltransferases are altered during intestinal cell development. Such alterations are also reflected in the modification of lectin binding to epithelial cells that occurs during postnatal development. In the rat small intestine, Etzler and Branstrator (1979) found developmental changes in the binding of RCL I, LTL, and WGA. RCL I stained the brush border of epithelial cells as early as 1 hr after birth. The staining became patchy at the cell surface over the next few days, reacting uniformly with the surface 5–14 days after birth. By 19–24 days postnatal, the epithelial cell surface began to lose its ability to react with RCL I, and by 30 days postnatal, the cell surfaces were no longer stained with RCL I. The onset of LTL staining was a much later event, commencing between 11 and 19 days after birth. By 28 days after birth, regional differences were apparent with respect to LTL binding to intestinal cell surfaces; brush borders of cells lining the villi in the distal portion of the small intestine were no longer bound by LTL. Wheat germ agglutinin (WGA) stained the brush border of epithelial cells from 1 hr after birth, until about postnatal day 19 when cells lining the villi were no longer stained with this lectin.

We have recently investigated the binding of sialic acid-specific and fucose-specific lectins to developing rat small intestinal cells (Taatjes and Roth, 1990). In line with the results detailed in Sections IV,A,2 and 3 concerning developmental-related changes in sialyltransferase and fucosyltransferase activities, as

FIG. 10. Low-power electron micrograph demonstrating *H. pomatia* lectin-gold binding sites in chick duodenum. In the center of the micrograph a prominent goblet cell is displayed, with intense gold particle labeling present in the goblet cell mucus (asterisk), in the Golgi apparatus, and in the apical plasma membrane (arrowheads). Label is also observable in the apical plasma membrane of adjacent absorptive cells (arrowheads). X 1,710. Bar = 5 μ m. (Reproduced from the *J. Cell Biol.* 1984, **98**, 399–406 by permission of the Rockefeller University Press.)

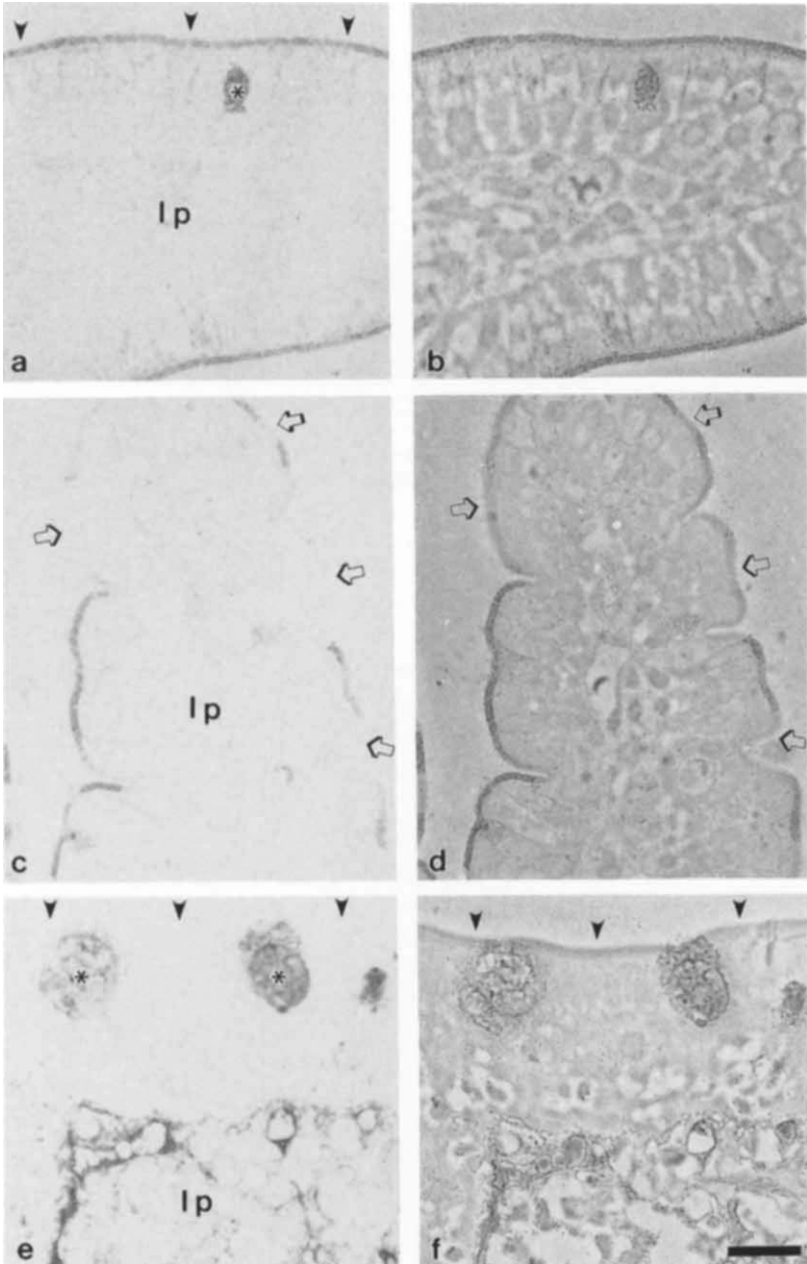

well as the lectin-binding results of Etzler and Branstrator (1974), we found that binding of SNL I, LFL, and UEL I to intestinal cells changed with postnatal development. SNL I (Fig. 11a,b) and LFL stained the brush border and mucus droplets in animals during the suckling phase. During weaning (day 23) we found that individual epithelial cells were no longer stained with SNL I (Fig. 11c,d and Fig. 12) and LFL. By adulthood, staining with these two sialic acid-specific lectins was restricted to goblet cell mucus and cells in the lamina propria and submucosa (Fig. 11e,f). In contrast, binding of fucose-specific UEL I was restricted to goblet cell mucus during the suckling phase, but by day 23 postnatal appeared in the brush border of some epithelial cells. In adults, intense staining with UEL I was found in goblet cell mucus and in the brush border of epithelial cells. All of these results taken together support the premise that during postnatal development of rat small intestine, a progressive change from sialylation to fucosylation of brush border glycoconjugates occurs.

Caldero *et al.* (1988) have performed a detailed investigation of changes in glycoconjugate composition of the rat colonic mucosa during development. They used a battery of eight fluorescein-conjugated lectins recognizing a variety of sugar residues. Their results demonstrated that each lectin showed a unique developmental staining pattern, including differences between the various regions of the colon. In all cases, the adult pattern of staining was achieved 25–30 days after birth.

Differentiation-related changes in intestinal cell glycosylation patterns have been described in adult animals during cell migration from crypts to the villus or lumen. Some of these were already described above (Section IV,A,5; Etzler and Branstrator, 1974). We have investigated the localization of LFL binding sites in the plasma membrane of rat colonic epithelial cells during differentiation (Taatjes and Roth, 1988). We found that in the crypt regions, goblet and absorptive cell precursors were stained along their entire plasma membrane (Fig. 13); that is, both apical and basolateral plasma membranes were stained. However, when cells reached the zone of migration (Eastwood, 1977) the staining with LFL became restricted to the apical plasma membrane (Fig. 13). This polarized staining remained a feature of fully mature epithelial cells (both absorptive and goblet) located at the intestinal lumen. These results suggest that a feature of

FIG. 11. Light micrographs illustrating the detection of SNL I-gold binding sites in epithelial cells during postnatal development of rat jejunum. At postnatal day 1 (a,b), staining is present in the epithelium along the apical plasma membrane (arrowheads) and in the goblet cell mucus (asterisk). By postnatal day 23 (c,d), individual cells in the epithelium are not stained by the SNL I-gold complex (arrows). In adult animals (e,f), the apical plasma membrane (arrowheads) of all epithelial cells is not stained by SNL I-gold complex, whereas goblet cell mucus (asterisks) and the plasma membrane of cells in the lamina propria (lp) are intensely stained. a,c,e. Bright-field micrographs; b,d,f. corresponding phase-contrast images. lp, lamina propria. X 368 (a–f). Bar = 5 μ m.

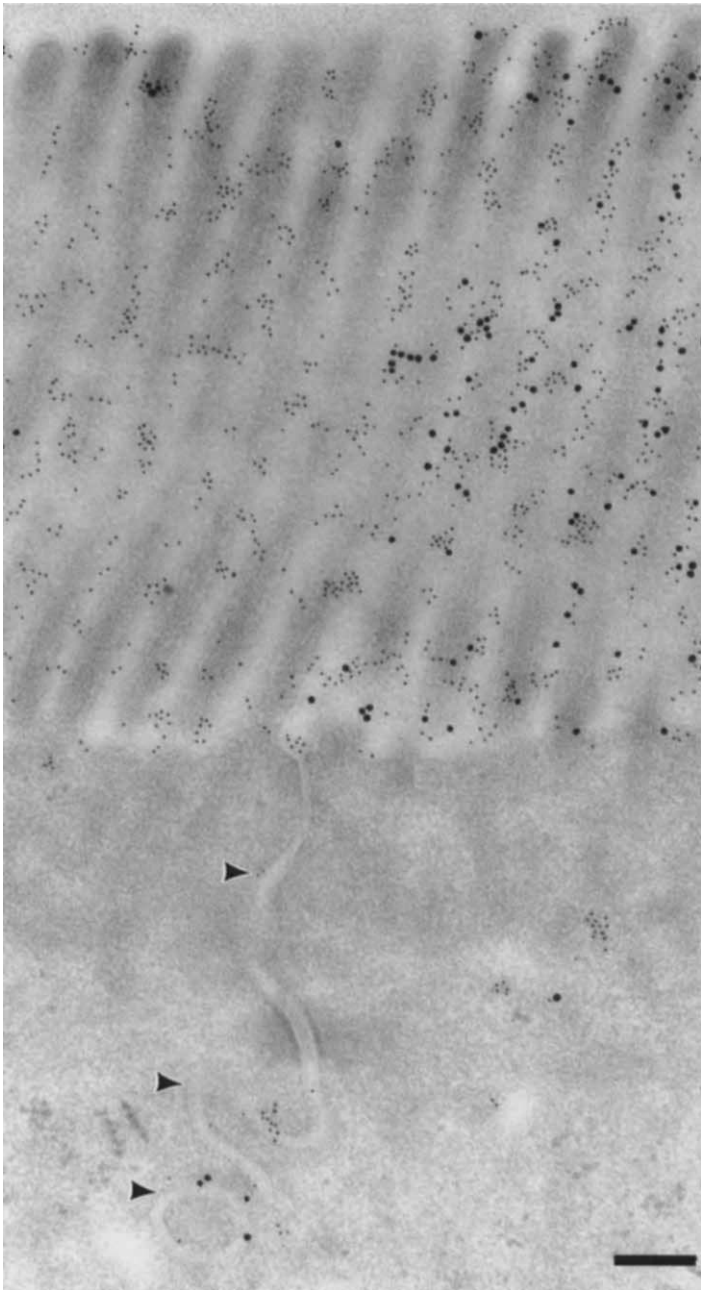

fully differentiated colonic epithelial cells is the polarization of the plasma membrane with respect to the distribution of sialic acid residues on membrane glycoconjugates. A similar phenomenon was apparent in the small intestine, although fully differentiated small intestinal epithelial cells display very sparse LFL binding sites.

B. GOLGI APPARATUS

In an early study, Kim and co-workers (1971) investigated the subcellular distribution of the then called "multienzyme system" of glycosyltransferases in rat small intestinal mucosal scrapings. They determined that the polypeptide : *N*-acetylgalactosaminyltransferase, galactosyltransferase, *N*-acetylglucosaminyltransferase, and *N*-acetylgalactosaminyltransferase were enriched in a smooth microsome fraction. This was the first detailed report of the localization of glycosyltransferases in intestinal tissue, and quite accurately determined them to be located in a fraction most likely representing Golgi apparatus membranes. In a subsequent investigation, Kim and Perdomo (1974) investigated the intestinal membrane distribution of five glycosyltransferases: two galactosyltransferases (acting on *N*- and *O*-linked oligosaccharides), sialyltransferase, fucosyltransferase, and *N*-acetylgalactosaminyltransferase. They found that all five enzymes were enriched in a smooth membrane fraction (Golgi apparatus), with only background amounts detected in a rough membrane fraction and a brush border membrane fraction.

More recently the techniques of immuno- and lectin cytochemistry have helped to unravel the pattern of glycosylation reactions in the intestinal cell Golgi apparatus. However, before we begin to detail these intestinal studies, it will be helpful to briefly review the concept of general Golgi apparatus glycosylation as formulated by the assimilation of data from several different techniques.

1. Subcompartmentation Model of the Golgi Apparatus

Several recent reviews have considered this topic in detail and the interested reader should refer to them for more information (Dunphy and Rothman, 1985; Farquhar, 1985; Kornfeld and Kornfeld, 1985; Roth, 1987a; Roth and Taatjes, 1989). Briefly, this model proposes that the Golgi apparatus cisternal stack is

FIG. 12. Demonstration of SNL I-gold binding sites in the jejunum of sections from postnatal day 23 rat. The apical plasma membrane (brush border) of adjacent epithelial cells is shown. Large gold particles (14-nm diameter) indicative of SNL I binding sites are restricted to the cell on the right. To rule out possible processing artifacts, this section was also stained with RCL I/asialofetuin-gold (small gold particles; 10-nm diameter). As can be seen, both cells are RCL I positive, indicating that loss of binding sites is specific for SNL I. The lateral plasma membrane (arrowheads) separating the two cells contains binding sites for both lectins. X 66,000. Bar = 0.15 μ m.

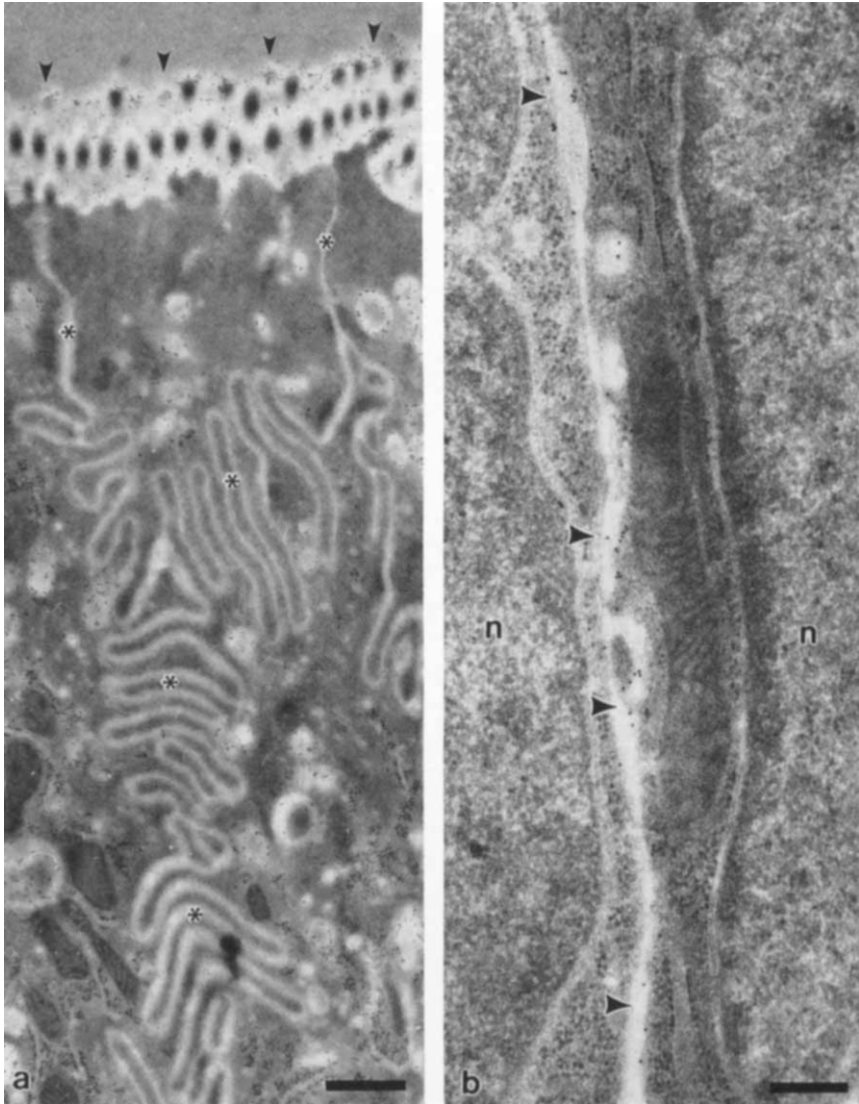

FIG. 13. Detection of sialic acid residues with the *Limax flavus* lectin/fetuin-gold technique at the plasma membrane of rat colonic absorptive cells. In differentiated cells at the surface epithelium (a), gold particle label is restricted to the apical plasma membrane (arrowheads). Note the lack of staining in the basolateral plasma membrane (asterisks). In contrast, the basolateral plasma membrane of undifferentiated absorptive cells from the crypts region (b) is intensely stained for sialic acid residues (arrowheads). n, nuclei of absorptive cells. X 18,000 (a); X 55,000 (b). Bars = 0.6 μm (a) and 0.2 μm (b). (Reproduced with permission from Taatjes and Roth, 1988.)

functionally subcompartmentalized with respect to the steps involved in the processing of oligosaccharide side chains of glycoconjugates. Although based upon the maturation of N-linked oligosaccharides of glycoproteins, support for this model has also been presented for the case of O-linked oligosaccharides of glycoproteins. Inherent in this concept is the premise that glycosyltransferases which act early in the pathway are preferentially located in cis-cisternae of the Golgi apparatus, whereas those acting at intermediate steps are located in middle cisternae, and those acting at terminal steps are housed in trans-cisternae. This compartmentation, or spatial separation, would allow the enzymes to act upon an oligosaccharide chain in an "assembly line" progression, without risk of interfering with the action of one another. This model is thus very attractive biochemically, and indeed has received much experimental support. For instance, in cell fractionation studies utilizing analytical sucrose gradients, activities for earlier and later acting oligosaccharide-processing enzymes were detected in distinct Golgi apparatus fractions (Dunphy *et al.*, 1981; Dunphy and Rothman, 1983; Goldberg and Kornfeld, 1983). More direct evidence, however, has been provided by numerous investigations analyzing the *in situ* cytochemical detection of various sugar residues with lectins (Pavelka, 1987; Roth *et al.*, 1988b) and by the immunolocalization of a few glycosyltransferases (Roth and Berger, 1982; Dunphy *et al.*, 1985; Roth *et al.*, 1985a). Indeed, the first direct demonstration of Golgi apparatus subcompartments was provided by the immunocytochemical localization of galactosyltransferase by Roth and Berger (1982). They found that galactosyltransferase immunoreactivity colocalized with thiamine pyrophosphatase activity in one or two trans-Golgi apparatus cisternae in HeLa cells. This result indicated that the Golgi apparatus contained at least two compartments with respect to glycosylation reactions: cis (defined as galactosyltransferase negative) and trans (defined as galactosyltransferase positive). The number of identifiable subcompartments increased to three with the localization of *N*-acetylglucosaminyltransferase I to middle cisternae of the Golgi apparatus stack (Dunphy *et al.*, 1985). Finally, the most distally acting glycosyltransferase, sialyltransferase, was detected in two trans-cisternae and a complex trans-tubular network continuous with these cisternae in rat hepatocytes (Roth *et al.*, 1985a). Interestingly, sialyltransferase immunoreactivity was found in portions of the Golgi apparatus stack which also contained cytochemically demonstrable thiamine pyrophosphatase activity, a classical trans-Golgi marker, or acid phosphatase (CMPase) activity, a classical marker for the GERL element of the Golgi apparatus. These results suggested that in hepatocytes the Golgi apparatus is composed of three subcompartments with respect to glycosylation reactions: cis, so far delineated by what it does not contain; middle, containing *N*-acetylglucosaminyltransferase I; and trans, containing sialyltransferase. We include the trans-tubular network (Rambourg and Clermont, 1990), or trans-Golgi network (Griffiths and Simons, 1986) as part of the trans-Golgi apparatus since

functionally it is involved in sialylation as are trans-cisternae, and structurally it is continuous with trans-Golgi cisternae (Roth *et al.*, 1985a; Taatjes and Roth, 1986). This view differs from that of Griffiths and Simons (1986), who regard the trans-Golgi network as perhaps a fourth Golgi subcompartment, separate from trans-cisternae. Moreover, other investigators have proposed that galactosyltransferase is housed in trans-Golgi apparatus cisternae, whereas sialyltransferase is separated and housed in the more distally located trans-Golgi network (Berger and Hesford, 1985; Thorens and Vassalli, 1986; Berger *et al.*, 1987). Several pieces of evidence contest this view. First, we have shown that sialyltransferase is not only localized in the trans-Golgi network of hepatocytes, but also quite clearly in two trans-cisternae of the Golgi apparatus stack (e.g., Fig. 3 in Roth *et al.*, 1985a). Second, by double-labeling immunofluorescence we found an identical codistribution of galactosyltransferase and sialyltransferase immunoreactivity in cultured rat hepatocytes (Taatjes *et al.*, 1987). Third, Geuze and co-workers (1985) found that galactosyltransferase was detectable in the trans-Golgi network, in addition to trans-cisternae in hepatoma cells and liver hepatocytes. Fourth, galactose residues detected with RCL I, were found in the trans-cisternae and trans-Golgi network of hepatocytes (Lucocq *et al.*, 1987). Clearly, the ability to resolve more and more Golgi apparatus subcompartments will come with the introduction of more Golgi apparatus-specific antibodies. Of certain importance for the previous discussion will be the simultaneous immunocytochemical demonstration of galactosyltransferase and sialyltransferase in the same Golgi apparatus at the electron microscopic level. Due to the constraints placed upon immunocytochemical investigations by antibody cross-reactivity with other animal species, this experiment has not proven possible. Moreover, cell-specific variability with respect to the organization of Golgi apparatus subcompartments may have been a factor in the above described discrepancies.

2. *Immunocytochemical Localization of Glycosyltransferases in Golgi Apparatus of Intestinal Epithelial Cells*

To this date, only two glycosyltransferases have been immunocytochemically detected in the Golgi apparatus of intestinal cells; yet, their localization has yielded most interesting results. After having reported on the localization of sialyltransferase in hepatocytes, we sought to expand on these findings by performing similar localizations on intestinal cells. When we examined the Golgi apparatus distribution of sialyltransferase in goblet cells from the rat colon, we observed the expected result (Fig. 14). Namely, immunoreactivity was restricted to trans-Golgi apparatus cisternae (Roth *et al.*, 1986). Likewise, sialic acid residues, as detected with LFL, were localized to trans-cisternae. However, quite surprisingly when we examined neighboring absorptive cells a quite different pattern of labeling emerged: the entire Golgi apparatus cisternal stack (with the exception of the fenestrated first cis-cisterna) was labeled (Figs. 14 and 15a). In a fashion similar

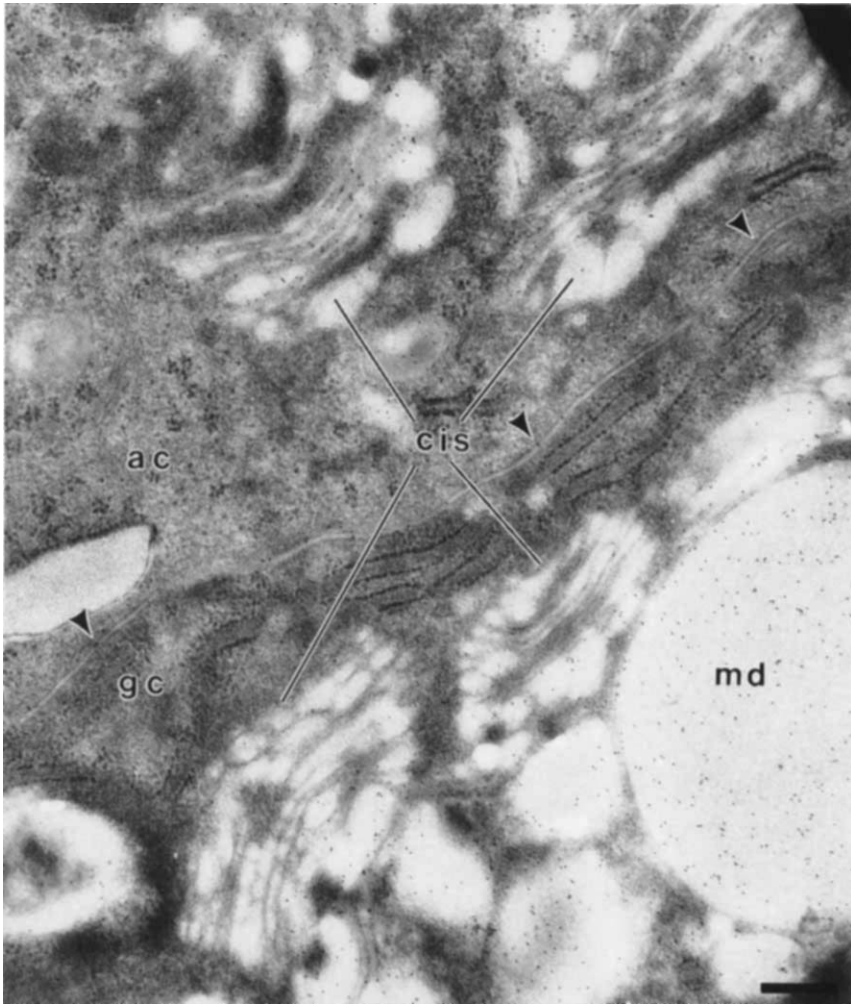

FIG. 14. Immunocytochemical localization of sialyltransferase in surface epithelial cells from rat proximal colon. Gold particle label is restricted to trans-Golgi apparatus cisternae in a goblet cell (gc), whereas in a neighboring absorptive cell (ac) label is detectable throughout the Golgi apparatus cisternal stack (with the exception of the fenestrated first cis-cisterna). Label is also present in the goblet cell mucus droplets (md) and in the lateral plasma membrane separating the two cells (arrowheads). X 25,500. Bar = 0.4 μ m. (Reproduced with permission from Roth *et al.*, 1986.)

to that observed in goblet cells, the distribution of sialic acid residues in absorptive cells was found to mirror that of the sialyltransferase enzyme (Fig. 15b). Quantitative evaluation of the distribution of sialyltransferase immunolabel in the Golgi apparatus of absorptive versus goblet cells confirmed the differential label

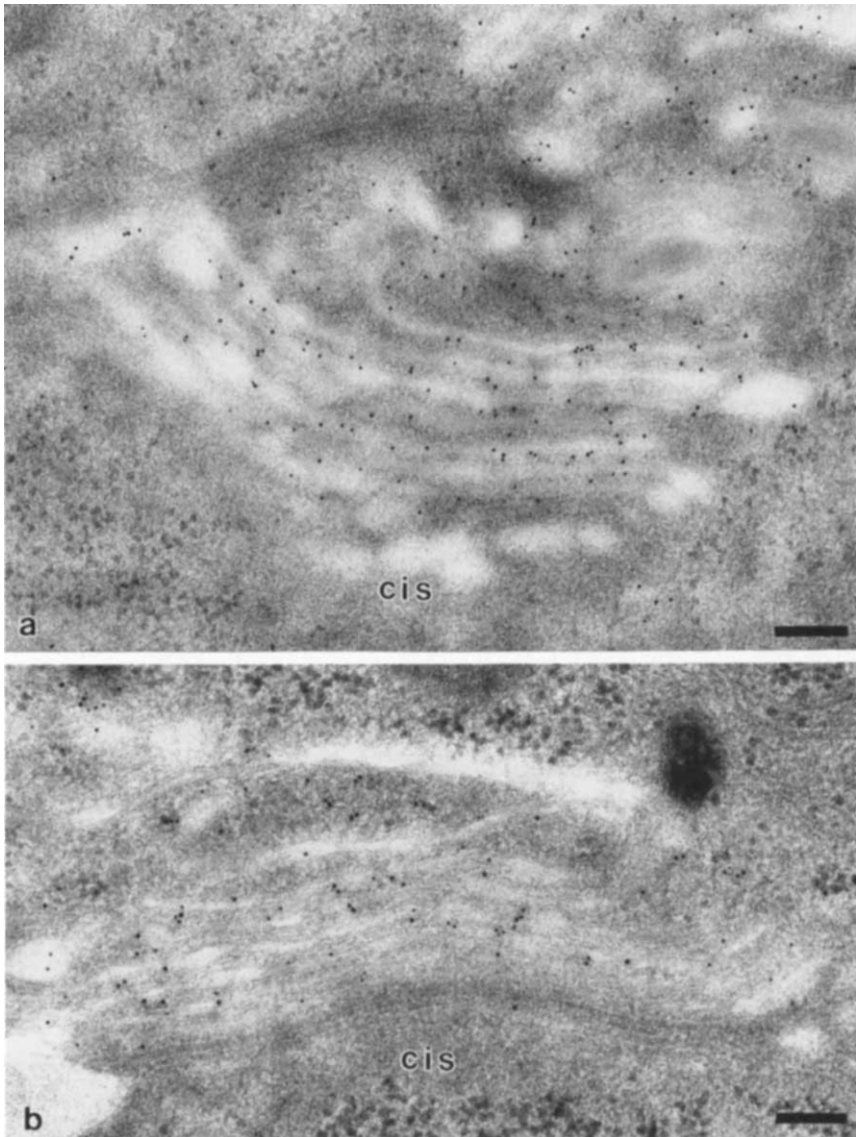

FIG. 15. Gold particle label for sialyltransferase (a) and sialic acid residues (b) is distributed throughout the absorptive cell Golgi apparatus cisternal stack (with the exception of the fenestrated first cis-cisterna) from rat proximal colon. X 63,000 (a); X 66,500 (b). Bar = 0.16 μm (a) and 0.15 μm (b). (Reproduced with permission from Roth *et al.*, 1986.)

TABLE II
 QUANTIFICATION OF IMMUNOLABEL FOR SIALYLTRANSFERASE IN
 RAT PROXIMAL COLONIC EPITHELIAL CELLS^a

Golgi apparatus cisterna ^b	Absorptive cell (n = 26)		Goblet cell (n = 23)	
	Gold particle/ μm	Total length (μm)	Gold particle/ μm	Total length (μm)
1	0.21 +/- 0.08	115.5	0.45 +/- 0.24	148.5
2	2.55 +/- 0.18	134.3	0.16 +/- 0.08	148.5
3	2.34 +/- 0.22	138.4	0.15 +/- 0.08	154.3
4	3.42 +/- 0.33	132.1	0.16 +/- 0.09	154.3
5	3.63 +/- 0.24	126.8	0.18 +/- 0.09	151.7
6	4.14 +/- 0.28	124.1	0.18 +/- 0.10	148.5
7	6.20 +/- 0.41	125.7	0.43 +/- 0.27	147.3
8			4.50 +/- 0.26	147.9
9			6.64 +/- 0.33	148.5

^aFrom Roth *et al.* (1986).

^bCisterna 1 designates the fenestrated first cis-cisterna and the following numbers the subsequent cisternae toward the trans side of the Golgi apparatus.

observed on micrographs (Table II). Moreover, it was apparent that although the labeling was diffuse throughout the Golgi apparatus of absorptive cells (with the exception of the fenestrated first cis-cisterna), the labeling intensity increased gradually from the cis to the trans side. This was the first demonstration of an apparent lack of subcompartmentation for a glycosyltransferase within the Golgi apparatus cisternal stack. In the same study, we found that another terminal glycosyltransferase, the blood group A *N*-acetylgalactosaminyltransferase, was distributed in strikingly different patterns in the Golgi apparatus of absorptive versus goblet cells from human intestine, restricted to trans-cisternae in goblet cell Golgi apparatus, and diffusely localized throughout the absorptive cell Golgi apparatus (Fig. 16). In accordance with the matching labeling in the Golgi apparatus for sialyltransferase and sialic acid residues in rat intestine, the distribution of blood group A substance (detected with a monoclonal antibody) mirrored that of the blood group A *N*-acetylgalactosaminyltransferase in both absorptive and goblet cells. These results were then confirmed and extended in further studies of human intestinal cells (Roth *et al.*, 1987, 1988c). Thus, for both N-linked oligosaccharide processing (sialyltransferase), as well as O-linked (blood group A *N*-acetylgalactosaminyltransferase) a terminal glycosyltransferase was not distributed in the Golgi apparatus cisternal stack as would be predicted by the subcompartmentation model. The implications of these findings for the elaboration of oligosaccharide side chains of glycoconjugates in intestinal absorptive cells are not clear. Although the subcompartmentation of glycosyltransferases would serve to prevent competing reactions which could alter the normal processing of oligosac-

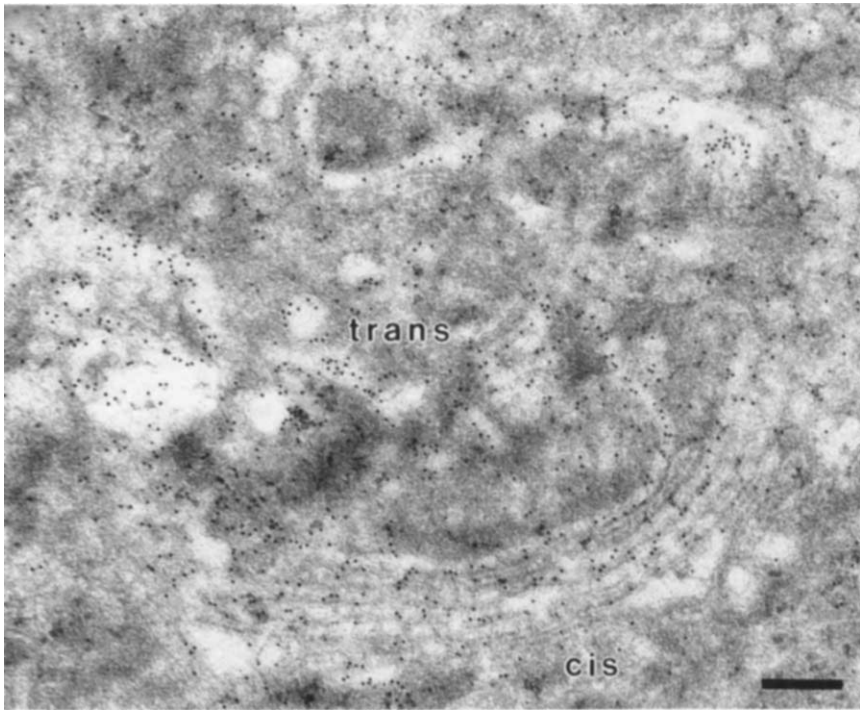

FIG. 16. Immunocytochemical localization of blood group A α 1,3-*N*-acetylgalactosaminyltransferase in absorptive cell Golgi apparatus from human ileum. Label is present throughout the cisternal stack and trans-tubular network of the Golgi apparatus. Note the complexity of the structures at the trans side of the Golgi apparatus. X 48,000. Bar = 0.2 μ m. (Reproduced with permission from Roth *et al.*, 1986.)

charides, it is not clear that normal processing requires such subcompartmentation. Other mechanisms such as the differential expression of the levels of two competing glycosyltransferases could favor one terminal glycosylation pattern over another. Besides, it is not known if the consequences of having oligosaccharides with one type of terminal structure would have functional significance over another for most proteins. It should be emphasized, though, that more insight into these questions awaits the immunolocalization of other glycosyltransferases in a variety of cell types.

Indirect support for these results has emerged from recent lectin-binding investigations. Diffuse labeling throughout the Golgi apparatus cisternal stack has been observed with RCL I in mouse epididymal cells (Yokoyama *et al.*, 1980) and rat absorptive intestinal cells (Pavelka and Ellinger, 1986). Hedman *et al.* (1986) observed label with LFL throughout the cisternal stack with the excep-

tion of one cis-cisterna in 3T3 cells. Similarly, Roth and co-workers (Lee *et al.*, 1989) found that LFL labeled the entire Golgi apparatus cisternal stack in CHO cells. Moreover, in the same study (Lee *et al.*, 1989) CHO cells were transfected with a cDNA coding for the β -galactoside α 2,6-sialyltransferase. This enzyme competed with the endogenous β -galactoside α 2,3-sialyltransferase for the termination of oligosaccharide chains. This competition was assessed by the binding of SNL I (specific for Neu5Ac α 2,6-Gal/GalNAc sequences) to sections from wild type and transfected cells. While SNL I did not stain wild type CHO cells, the Golgi apparatus of transfected cells was labeled throughout the entire cisternal stack. Thus, in both wild type and transfected cells, sialic acid residues were not restricted to trans-cisternae of the Golgi apparatus.

Such lectin-binding studies identify any glycoconjugate in the Golgi apparatus carrying the required sugar residues. Although the nature and extent of recycling of glycoconjugates from the plasma membrane through the Golgi apparatus remains controversial (Farquhar, 1985; see Snider and Rogers, 1985, 1986; Neefjes *et al.*, 1988; Reichner *et al.*, 1988, for disparaging views) such recycling could at least in part explain the presence of complex-type oligosaccharide chains in the middle and cis regions of the Golgi apparatus cisternal stack. For this reason, we feel that it is most important to determine the intra-Golgi apparatus distribution of a particular glycosyltransferase before surmising that the pattern of glycoconjugate localization represents the site of glycosyltransferase activity.

3. Demonstration of Lectin-Binding Sites in Intestinal Cell Golgi Apparatus

In contrast to the relatively few investigations detailing the localization of glycosyltransferases within the intestinal cell Golgi apparatus, many studies have employed lectins for the demonstration of sugar residues therein (Pavelka, 1987). Preembedding methods employing peroxidase-conjugated lectins, as well as postembedding methods employing colloidal gold-labeled lectins and glycoproteins have been used. Although the methods and animal species investigated may differ among the various investigators, the lectin-binding patterns to intestinal goblet and absorptive cell Golgi apparatus may be summarized as in Table III. As can be seen from the table, the interpretations of lectin-binding studies by various investigators tend to overlap, but also display variability. Such discrepancies may result from species variability, variability among intestinal segments as well as crypt versus villus regions, and methodology (pre-versus postembedding, tissue fixation and processing, probe preparation, etc.). Moreover, probably of equal importance is the very subjective nature of the interpretation of lectin labeling patterns within the Golgi apparatus. It may be rather easy to distinguish between cis- and trans-sides of the Golgi apparatus cisternal stack, yet what defines where the cis region ends and middle begins, or where middle ends and trans begins? How many cisternae compose the desig-

TABLE III
LECTIN BINDING TO GOLGI APPARATUS IN
INTESTINAL EPITHELIAL CELLS^a

Lectin	Goblet cell			Absorptive cell			References
	cis	middle	trans	cis	middle	trans	
Con A	nd	nd	nd	+	+/-	-	Pavelka and Ellinger (1985)
SBL	+	+	-	nd	nd	nd	Tsuyama <i>et al.</i> (1986)
PSL	nd	nd	nd	+	+/-	-	Pavelka and Ellinger (1989a)
LCL	nd	nd	nd	+	-	-	Pavelka and Ellinger (1989a)
HPL	+	+/-	+/-	nd	nd	nd	Murata <i>et al.</i> (1986)
	+	+/-	+	+	-	-	Pavelka and Ellinger (1985); Ellinger and Pavelka (1988b)
GSL I	+	-	+	nd	nd	nd	Roth (1984)
	+	+	-	nd	nd	nd	Ellinger and Pavelka (1988b)
RCL I	-	+/-	+	-	+	+/-	Pavelka and Ellinger (1985, 1989b)
LFL	-	+	-	nd	nd	nd	Tsuyama <i>et al.</i> (1986)
	-	-	+	+/-	+	+	Roth <i>et al.</i> (1986)
UEL I	-	-	+	-	+/-	+	Ellinger and Pavelka (1988a)

^a+, Staining present; -, not detected; nd, not determined.

nated cis, middle, and trans regions of the stack? In the absence of specific markers, these borders seem to be arbitrarily defined by individual investigators. The situation is further complicated by cell type variability. For instance, some cell types such as hepatocytes may contain Golgi apparatus with as few as three cisternae, whereas the Golgi apparatus of goblet cells may possess up to 20 cisternae. The number of cisternae within a given cell may also vary depending upon the functional condition of the cell. Finally, the plane of section must be considered when interpreting the number of cisternae within, as well as the orientation of the Golgi stack. This may necessitate examining serial sections in order to exclude the possibility of missing a particular region of the cisternal stack in a given section. For instance, Orci *et al.* (1986) performed a serial sectioning analysis of the transport of horseradish peroxidase from the cell surface to the Golgi apparatus in insulin-secreting B cells. Their results showed quite convincingly that what appeared to be a cis- or trans-cisterna in a random section could always be traced to a position in the Golgi stack intermediate (i.e., middle cisternae) between the cis and trans poles. Taking all of these points into consideration, and assuming some subjectivity on our part, we propose the following scheme for the localization of sugar residues within the intestinal cell Golgi apparatus. In absorptive cells, mannose/glucose residues are restricted to cis and middle portions of the cisternal stack (Pavelka and Ellinger, 1985, 1989a); *N*-acetylgalactosamine residues are concentrated in cis and trans regions (Pavelka and Ellinger, 1985; Ellinger and Pavelka, 1988b); galactose residues to

trans- and variably middle cisternae (Pavelka and Ellinger, 1985); fucose residues to middle/trans regions (Ellinger and Pavelka, 1988a); and sialic acid residues diffuse throughout the stack, but concentrated in trans-cisternae (Roth *et al.*, 1986). In goblet cells, mannose/glucose residues are restricted to cis/middle portions of the stack (Tsuyama *et al.*, 1986); *N*-acetylgalactosamine residues to cis and trans regions (Roth, 1984); galactose residues to middle/trans portions of the stack (Pavelka and Ellinger, 1985, 1989b); fucose residues to trans-cisternae (Ellinger and Pavelka, 1988a); sialic acid residues to trans-cisternae (Roth *et al.*, 1986); sialic acid α 2,3-linked and α 2,6-linked to galactose concentrated in trans-cisternae (Sata *et al.*, 1989; Taatjes and Roth, 1990). In a single study, Ellinger and Pavelka (1988b) have reported that α -galactose residues as detected with *Griffonia simplicifolia* isolectin I-B₄, are restricted to cis- cisternae in intestinal goblet cells.

C. POST-GOLGI APPARATUS DISTRIBUTION OF GLYCOSYLTRANSFERASES: FACT OR ARTIFACT?

It is well established that glycosyltransferases exist outside of their usual location as Golgi apparatus integral membrane proteins; specifically in cellular plasma membranes and in soluble form in a number of secretions, predominantly milk and colostrum (Andrews, 1970; Barker *et al.*, 1972; Paulson *et al.*, 1977), and serum (Hudgin and Schachter, 1971; Fujita-Yamaguchi and Yoshida, 1981; Kaplan *et al.*, 1983). Immunocytochemical methods have indicated the presence of galactosyltransferase (Pestalozzi *et al.*, 1982; Davis *et al.*, 1984; Roth *et al.*, 1985b; Shaper *et al.*, 1985; Bayna *et al.*, 1988), *N*-acetylgalactosaminyltransferase (Balsamo *et al.*, 1986), blood group A *N*-acetylgalactosaminyltransferase (Roth *et al.*, 1987, 1988c), and sialyltransferase (Roth *et al.*, 1986; Taatjes and Roth, 1988; Taatjes *et al.*, 1988a) at the plasma membrane of many cell types. A detailed discussion of cell surface glycosyltransferases is beyond the scope of this review. However, interested readers should consult several excellent reviews of this area (Pierce *et al.*, 1980; Strous, 1986; Shur, 1989). In this section we will focus on the evidence pertaining to the presence of glycosyltransferases outside of the Golgi apparatus in intestinal cells. Such evidence has been presented from three types of experiments: (1) measurement of glycosyltransferase activities in plasma membrane fractions; (2) autoradiographic detection of glycosyltransferase activity in plasma membranes; and (3) *in situ* immunocytochemical localization of glycosyltransferases.

Many studies have reported the presence of glycosyltransferase activity in the plasma membranes of intestinal epithelial cells, and these results were already presented in Sections IV,A,1 and 2. Briefly, activities for galactosyltransferase and sialyltransferase have been detected on the apical and basolateral plasma membranes of intestinal epithelial cells (Weiser, 1973a,b; Weiser *et al.*, 1978).

Using a different methodology, Bennett *et al.* (1987) have reported on the existence of an active sialyltransferase at the microvillar surface of rat intestinal absorptive cells. They injected CMP-[³H]sialic acid into the intestinal lumen, followed by visualization of autoradiographic products at the light microscopic level. Injection period was restricted to 5 min to ensure that reaction product reflected cell surface phenomena and not activity from the Golgi apparatus. They observed a moderate autoradiographic reaction at the microvillar surface of small intestinal absorptive cells, yet found no reaction at the luminal surface of epithelial cells from gallbladder, ciliary body, and iris. Likewise, the injection of UDP-[³H]galactose resulted in no reaction at the cell surface of all these cells, including intestinal absorptive cells. They attributed these results to reflect the presence of a sialyltransferase capable of sialylating endogenous acceptors at the luminal surface of small intestinal absorptive cells. In light of immunocytochemical results to be discussed below, it would have been of interest if Bennett and co-workers had examined reaction in the large intestine as well.

As mentioned previously, several immunocytochemical investigations at both the light and electron microscopic levels have reported the presence of immunoreactivity for glycosyltransferases at the plasma membrane, as well as other post-Golgi apparatus sites of intestinal epithelial cells (Pestalozzi *et al.*, 1982; Roth *et al.*, 1985b, 1986, 1987, 1988c; Taatjes and Roth, 1988; Taatjes *et al.*, 1988a). Berger and co-workers (Pestalozzi *et al.*, 1982), observed at the light microscopic level label with an affinity-purified galactosyltransferase antibody at the apical, but not basolateral plasma membrane of human jejunal enterocytes. Roth *et al.*, (1985b) performed a similar investigation using postembedding protein A-gold immunocytochemistry at the electron microscopic level. An affinity-purified antibody against human milk galactosyltransferase was applied to thin sections from human duodenum embedded in Lowicryl K4M. Intense gold particle label was observed at the apical (brush border), as well as basolateral plasma membrane of enterocytes. The intensity of label decreased on the lateral plasma membrane as it approached the basal membrane. Staining was completely abolished by preabsorption of the antibody with purified galactosyltransferase antigen. However, the validity of these results as representing true cell surface, or ecto-galactosyltransferase has recently been challenged. First, Boyle *et al.* (1986) using analytical subcellular fractionation techniques, reported that galactosyltransferase activity was confined to the Golgi apparatus fraction in human jejunal biopsy homogenates, with no significant amount detectable in the brush border membrane fraction. They postulated that the staining observed by Roth *et al.* (1985b) was probably due to contaminating immunoglobulins present in the milk used as the source of the galactosyltransferase antigen. An alternative explanation for their inability to detect significant amounts of galactosyltransferase activity in their plasma membrane fraction could have resulted from failure to block endogenous intestinal nucleotide py-

rophosphatase. As reported by Lau and Carlson (1981) (and discussed in Section IV,A,1), when measuring glycosyltransferase activities in tissues rich in nucleotide pyrophosphatase activity (such as intestinal mucosa), precautions must be taken, including inclusion of EDTA and soybean trypsin inhibitor, to ensure that glycosyltransferase degradation does not occur.

A second, and perhaps more troublesome critique, has been the recent revelation that polyclonal antibodies raised against glycoproteins may contain clones directed against carbohydrate epitopes of the antigen (Feizi and Childs, 1987). Human milk galactosyltransferase possesses blood group-related carbohydrate structures as part of its oligosaccharide constituency. Indeed, Feizi and co-workers (Childs *et al.*, 1986) have reported immunochemical data demonstrating that the affinity-purified antibody raised against the human milk galactosyltransferase used in the above-mentioned studies (Pestalozzi *et al.*, 1982; Roth *et al.*, 1985b) contains a minor population of antibodies directed against the blood group-related carbohydrate moiety of the enzyme. When used in immunofluorescence experiments, these antibodies against carbohydrate epitopes of galactosyltransferase intensely stained the brush border of intestinal epithelial cells (Childs *et al.*, 1986). This staining could be abolished by preabsorbing the antibodies with blood group substances, suggesting that the staining did not reflect galactosyltransferase immunoreactivity at the brush border, but rather that of blood group substances. How do these results relate to those published by Roth *et al.* (1985b) described above? Perhaps a reevaluation is necessary, employing a galactosyltransferase antibody preabsorbed with blood group carbohydrate structures. Alternatively, antibodies could be raised against a deglycosylated form of the enzyme and used for immunocytochemistry. However, it is not clear what effect removal of the carbohydrate moieties would have on the folding and three dimensional conformation of the enzyme. Resulting antibodies could potentially recognize antigenic structures not present on the molecule *in situ*. Perhaps the best method for resolving this discrepancy would be to utilize the recent successful cloning of several galactosyltransferases (Narimatsu *et al.*, 1986; Shaper *et al.*, 1986, 1988; Masri *et al.*, 1988; Nakazawa *et al.*, 1988; D'Agostaro *et al.*, 1989; Masibay and Qasba, 1989) to produce polypeptide epitope-purified antibodies (Taatjes *et al.*, 1988a) recognizing only the protein portion of the enzyme as related below.

During our studies on the subcompartmentation of sialyltransferase in the Golgi apparatus of intestinal epithelial cells, we noted predominant staining over a variety of post-Golgi apparatus structures, including plasma membrane and mucus droplets (Roth *et al.*, 1986). In view of the findings of Childs *et al.* (1986) concerning the contamination of galactosyltransferase antisera with carbohydrate-directed antibodies noted above, we sought to determine if the immunolabeling we observed for sialyltransferase outside of the Golgi apparatus represented true sialyltransferase enzyme, or rather was due to nonspecific

cross-reaction with carbohydrate antigens. For this purpose we took advantage of the recent cloning of the gene for this particular sialyltransferase (Weinstein *et al.*, 1987) to prepare polypeptide epitope-purified polyclonal sialyltransferase antibodies (Fig. 17) by adsorption to a recombinant β -galactosidase-sialyltransferase fusion protein produced in *Escherichia coli* (Taatzjes *et al.*, 1988a). Because the fusion protein is nonglycosylated, the resulting purified antibodies recognize only protein epitopes of the sialyltransferase. Using these antibodies for immunoelectron microscopy, we observed immunoreactivity to the sialyltransferase polypeptide in several post-Golgi apparatus structures, in addition to the Golgi apparatus, in both absorptive and goblet cells from the rat colon (Taatzjes *et al.*, 1988a). In absorptive cells, labeling was found in the apical and basolateral plasma membranes, lysosomes, and multivesicular bodies, and at the

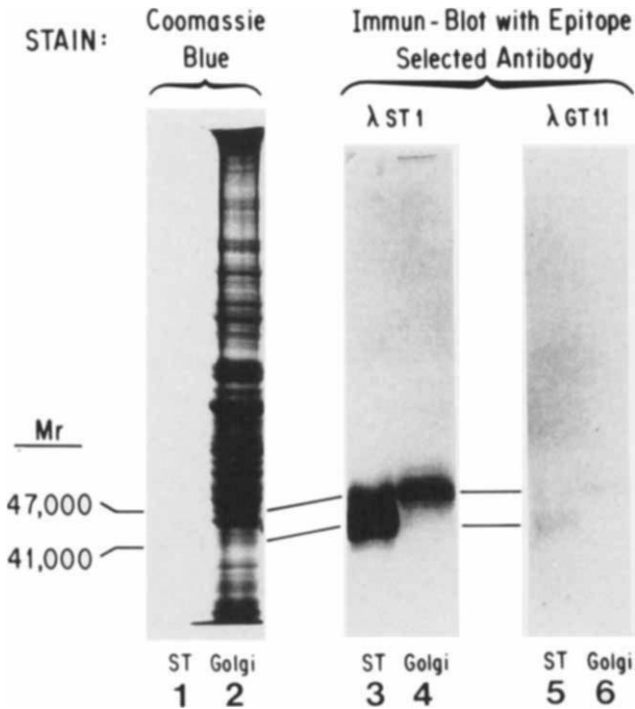

FIG. 17. Characterization of a β -galactosidase-sialyltransferase fusion protein epitope purified antibody (λ ST1). SDS-polyacrylamide gels of rat liver Golgi apparatus (lanes 2, 4, 6) and purified Gal β 1.4GlcNAc α -2,6 sialyltransferase (lanes 1, 3, 5) were stained by Coomassie blue (lanes 1 and 2) or processed as Immun-blot with fusion protein epitope-purified antibody (lanes 3 and 4) or by antibody mock-purified with β -galactosidase without fused sialyltransferase (λ GT11; lanes 5 and 6). The λ ST1 antibody recognizes both the purified and Golgi apparatus forms of sialyltransferase, while the λ GT11 control antibody shows only a background level of staining. (Reproduced with permission from Weinstein *et al.*, 1987.)

limiting membrane of apical cytoplasmic vesicles (Fig. 18). In goblet cells (Fig. 19a), label was detected in the apical and basolateral plasma membranes and in mucus droplets (both in the lumen and at the limiting membrane). Surprisingly, label was undetectable (including the Golgi apparatus) in all regions of the small intestine from the same animals (Fig. 19b), as presented in Table IV, and previously detailed in Section IV,A,1.

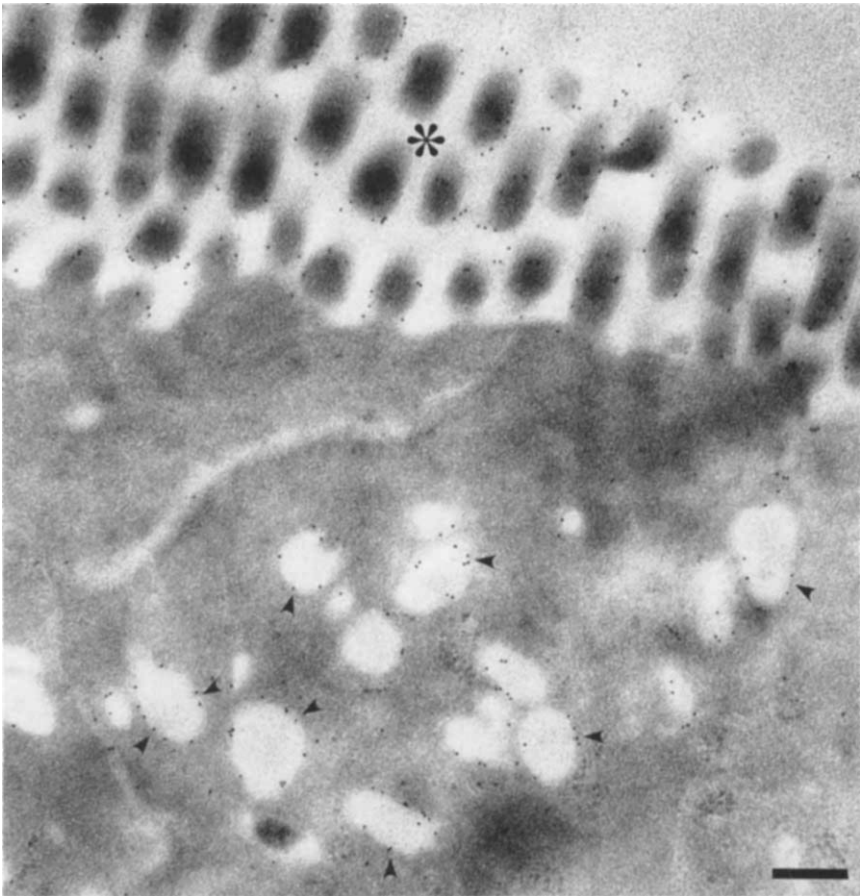

FIG. 18. Immunocytochemical localization of sialyltransferase with β -galactosidase-sialyltransferase fusion protein epitope-purified antibody in an absorptive cell from rat proximal colon. Sialyltransferase immunoreactivity is detectable in the apical plasma membrane (asterisk) and along the inner aspect of the limiting membrane of apical cytoplasmic vesicles (arrowheads). X 50,000. Bar = 0.2 μ m. (Reproduced with permission from Taatjes *et al.*, 1988a.)

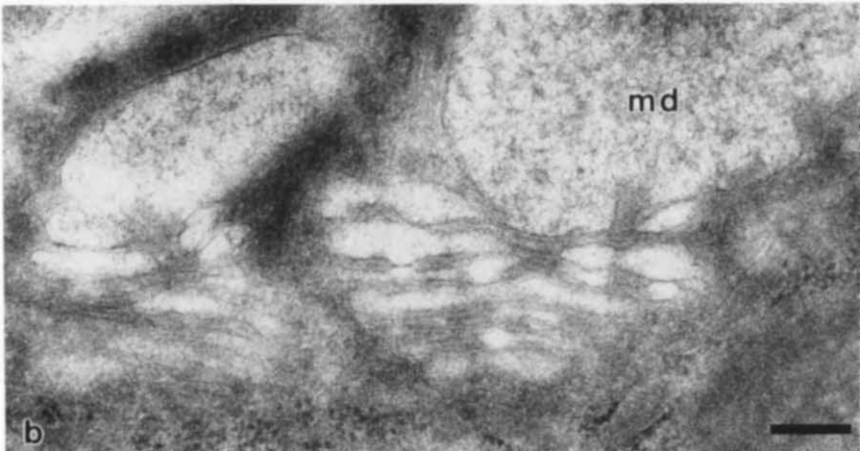
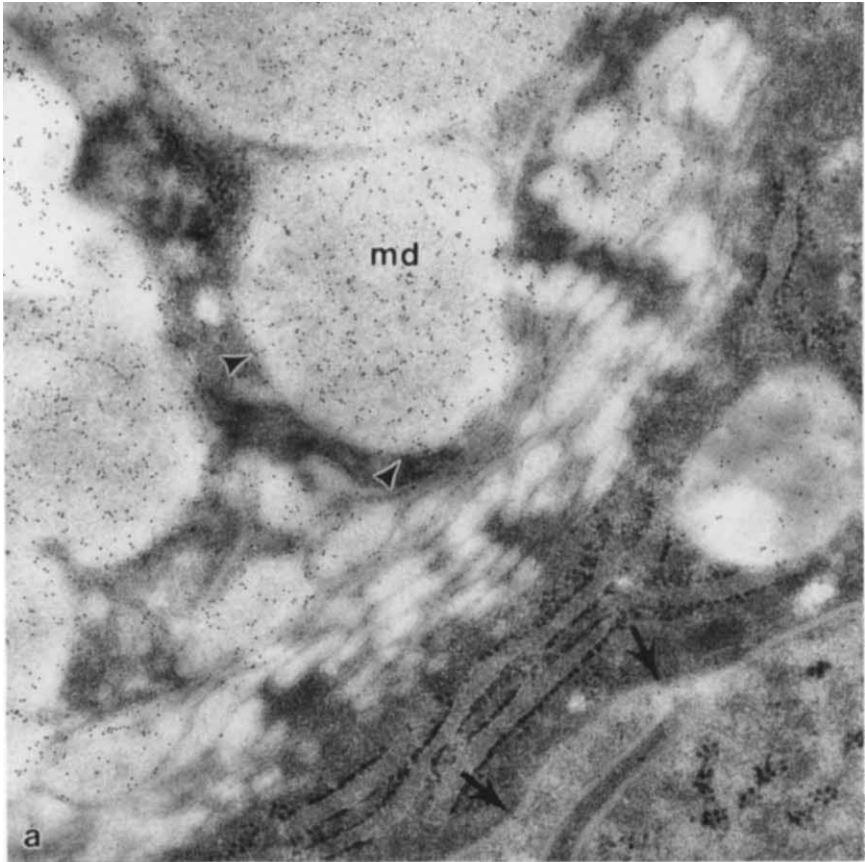

TABLE IV
DISTRIBUTION OF SIALYLTRANSFERASES IN RAT INTESTINE^a

Intestinal segment	Sialyltransferase activity ^b	
	Gal β 1,3(4)GlcNAc α 2,3-ST ^c	Gal β 1,4GlcNAc α 2,6-ST ^d
Duodenum	0	0
Jejunum	0	0
Ileum	0	0
Colon	72	14

^aFrom Taatjes *et al.* (1988a).

^bActivity expressed as picomole of [¹⁴C]Neu5Ac transferred per milligram of protein/hour for both sialyltransferases.

^cA value of 0 indicated activity not detected with limit of detection at 10 pmol of [¹⁴C]Neu5Ac/milligram of protein/hour.

^dA value of 0 indicates activity not detected with limit of detection at 1 pmol of [¹⁴C]Neu5Ac/milligram of protein/hour.

Thus, the powerful combination of molecular cloning and immunocytochemistry provided very strong support to the contention that glycosyltransferases are also housed in cellular locations distal to the Golgi apparatus. However, the question must be asked whether the post-Golgi apparatus localizations of sialyltransferase in rat intestine are functionally significant. If we consider first the label present in the mucus droplets, it is possible that this luminal sialyltransferase continues its function in the sialylation of glycoproteins. Recently, Paulson and co-workers (Colley *et al.*, 1989) investigated the conversion of membrane-bound Golgi apparatus sialyltransferase to a secretory form of the protein. By replacing the NH₂-terminal signal anchor with the cleavable signal peptide from γ -interferon, and transfecting CHO cells with this sialyltransferase expression vector, they were able to show that this construct was secreted from the cell with a half time of 2–3 hr. Most importantly, this secreted form of sialyltransferase contained the catalytic portion of the enzyme and was enzymatically active. By analogy, the sialyltransferase located in the mucus may represent a form of the enzyme rendered soluble by cleavage of the NH₂-terminal signal anchor by an endogenous protease in the trans region of the Golgi apparatus. Indeed, precedence for such a situation has been documented for the con-

FIG. 19. Immunocytochemical demonstration of sialyltransferase in goblet cells using β -galactosidase-sialyltransferase fusion protein epitope-purified antibody. (a) Gold particle label indicative of sialyltransferase immunoreactivity is found in trans-cisternae of the Golgi apparatus (facing the mucus droplets), in the mucus droplet lumen (md), and along their limiting membrane (arrowheads), and along the lateral plasma membrane (arrows) of goblet cells from rat proximal colon. In contrast, immunoreactivity for sialyltransferase is undetectable in both the Golgi apparatus and mucus droplets (md) of goblet cells from rat jejunum (b). X 50,000 (a and b). Bar = 0.2 μ m. (Reproduced with permission from Taatjes *et al.*, 1988a.)

version of the blood group A *N*-acetylgalactosaminyltransferase from a membrane-associated to a nonmembrane-associated form in the trans-tubular network of human intestinal goblet cells (Roth *et al.*, 1988c). In this case, active enzyme has been directly demonstrated in the mucin released from the goblet cells (Ornftoft *et al.*, 1987). Of course, even if the enzyme is active, continued glycosylation would require the transport of the appropriate nucleotide sugar from the cytoplasm into the lumen by a nucleotide sugar antiport protein (Hirschberg and Snider, 1987). Thus, whether or not the sialyltransferase plays a functional role in the mucus is still an open question. Once it is released with the mucin into the lumen of the gut, it most likely has no catalytic activity due to lack of substrates, and is unlikely to play any role in the physical properties of the mucin since it would be such a minor component of the total protein (estimated at less than 0.0001% by activity).

The demonstration of sialyltransferase at the apical and basolateral plasma membrane of intestinal cells provides further evidence for the existence of ecto-glycosyltransferases. The unambiguous existence of cell surface glycosyltransferases has been difficult to establish since Roseman (1970) first proposed their role in cell recognition and adhesion. However, in recent years Shur and co-workers, in a series of elegant studies, have succeeded in demonstrating the role of cell surface galactosyltransferase in such diverse functions as fertilization, preimplantation embryonic development, implantation, mesenchymal cell migration on substrates, and growth control in normal, neoplastic, and metastatic cells (Shur, 1989). Presently, it is not clear if ecto-sialyltransferase plays a functional role in intestinal cells or if its occurrence simply reflects its less restricted distribution in the post-Golgi apparatus membranes of these cells. In this respect, it would be of interest to determine if other glycosyltransferases in these cells have similar or different distributions, since similar distributions would favor the view that their existence on the cell surface is a consequence of an alteration in the underlying mechanism which would restrict their subcellular localization to the Golgi apparatus. Indeed, this view is supported by the immunocytochemical localization of the blood group A *N*-acetylgalactosaminyltransferase in both the apical and basolateral plasma membrane of human intestinal epithelial cells (Roth *et al.*, 1987). On the other hand, Lopez *et al.* (1989) have reported that at least in F9 embryonal carcinoma cells the levels of cell surface (ecto-galactosyltransferase) and Golgi apparatus galactosyltransferase change relative to one another during cell differentiation, suggesting that these functionally and distinct pools of galactosyltransferase are independently and differentially regulated. This would indicate that we should not necessarily think of ecto-glycosyltransferases as representing nonspecific vesicular transport of the Golgi apparatus form of the enzyme to the plasma membrane, but rather as an independently regulated entity of its own.

V. Effects of Exogenous Agents on Intestinal Glycosyltransferase Activity and Glycosylation

A. HORMONES

In adult rats, a continuous subcutaneous administration of testosterone for fourteen days resulted in qualitative and quantitative changes in the glycosphingolipid composition of rat small intestinal mucosa (Dahiya *et al.*, 1989). These changes were accompanied by increases in the enzymatic activities of CMP-*N*-acetylneuraminic acid : lactosylceramide sialyltransferase and UDP-galactose : lactosylceramide galactosyltransferase. The authors proposed that testosterone induced the activities of the two glycosyltransferases to increase, resulting in changes in intestinal mucosa glycosphingolipid composition. In a similar investigation, Dudeja *et al.* (1988) analyzed the activities of the same two glycosyltransferases reported above, in Golgi apparatus membranes, in response to subcutaneous administration of the synthetic glucocorticoid dexamethasone. They found that the activities of both glycosyltransferases were elevated in response to dexamethasone administration. They speculated that the increase in galactosyltransferase activity may have resulted from an increased membrane fluidity caused by the dexamethasone. However, they could not attribute the increase in sialyltransferase activity to the same cause.

Several investigations have been aimed at examining the effect of hormone administration on glycosylation activity in developing intestine. As described in Sections IV,A,2 and 3, the postnatal development of rat small intestine is characterized by a decrease in sialyltransferase activity, with a concomitant increase in fucosyltransferase activity. A postnatal injection of cortisone caused precocious changes in the activities of sialyltransferase and fucosyltransferase in the mucosal fractions from 2-week-old rats (Chu and Walker, 1986). Specifically, cortisone administration resulted in a 50% decrease in sialyltransferase activity and an 8-fold increase in fucosyltransferase activity as compared to control animals. Likewise, glycosidic-bound sialic acid content was significantly decreased, while glycosidic-bound fucose content significantly increased in the hormone-treated animals. Walker and co-workers (Ozaki *et al.*, 1989) have also shown that cortisone injection into suckling rats causes a precocious increase in the activities of two developmentally regulated galactosyltransferases: the UDP-Gal : GlcNAc (β 1-4)-galactosyltransferase was increased 2.7-fold and the UDP-Gal : GalNAc(β 1-3)-galactosyltransferase activity was increased 1.8-fold.

In an earlier study, Mahmood and Torres-Pinedo (1985) injected suckling rats with cortisone, thyroxine, epidermal growth factor, or insulin and measured the effect on the intestinal microvillar membrane content of sialic acid and fucose, as well as subsequent lectin binding. Cortisone treatment was found to lower sialic acid content and raise fucose content of microvillar membranes, as well as

increase the incorporation of [³H]fucose into these membranes. These results were also reflected in the binding of ¹²⁵I-labeled lectins to purified microvillar membrane preparations; cortisone administration decreased the binding of WGA to microvillar membranes, while increasing the binding of UEL I and PNL. Thyroxine treatment had a similar effect as cortisone on membranous fucose content and UEL I binding, but did not alter the incorporation of [³H]fucose into membranes or the sialic acid content of membranes. Epidermal growth factor and insulin did not affect any of these parameters. Thus, these results demonstrated that only cortisone administration to suckling rats induced precocious changes in sialic acid and fucose content of microvillar membranes normally associated with postnatal intestinal development.

Kolinska *et al.* (1988) examined the effect of hydrocortisone administration on sialyltransferase activity in the crypts versus villus of 10-day-old rat small intestine. They found that the decrease in sialyltransferase activity induced by hydrocortisone administration occurred mainly in the crypt cells.

B. DRUGS AND OTHER NOXIOUS STIMULI

Treatment of rats with the microtubule-disrupting drug colchicine or with turpentine results in an increase in the serum level of sialyltransferase activity (Mookerjea *et al.*, 1977; Kaplan *et al.*, 1983). Ratnam *et al.* (1987) speculated that some of this increase in serum sialyltransferase may result from secretion from the small intestine. They injected rats with colchicine and then 4 hr later measured the activity of the α 2,6-sialyltransferase in the homogenates from jejunal slices. They found that secretion of soluble sialyltransferase into the medium was elevated in the animals treated with colchicine, as compared to control animals. A similar increase in intestinal and serum sialyltransferase activity has also been shown to be induced by inflammation caused by a standardized 25% body surface area thermal injury in rats (Chu *et al.*, 1988). These results thus suggested that intestinal sialyltransferase may form part of the acute phase response to inflammation. However, we believe that this sialyltransferase originates from cells of the lamina propria, and not from intestinal epithelial cells. As pointed out in Sections IV,A,1 and IV,C, immunoreactivity and enzymatic activity for the α 2,6-sialyltransferase were undetectable in rat small intestinal mucosa.

Colchicine is normally used as a depolymerizing agent for microtubules to study cellular processes which may be microtubule-dependent. Indeed, Hugon *et al.* (1987) performed such a study on mouse jejunal epithelial cells to investigate the role of microtubules in the migration of glycoproteins from the Golgi apparatus to the apical and basolateral plasma membranes. They examined by autoradiography the incorporation of [³H]fucose into glycoconjugates in explants of mouse jejunum cultured in a medium containing colchicine. They

found that colchicine inhibited the labeling of the brush border by 67%, while labeling of the basolateral plasma membrane increased 114%. Similar results were also obtained with the microtubule-disrupting drug nocodazole. These results suggested that some glycoproteins destined for the apical plasma membrane may be rerouted to the basolateral plasma membrane in the presence of colchicine and thereby suggests a role for microtubules in the transport of glycoconjugates from the Golgi apparatus to the apical plasma membrane in polarized intestinal absorptive cells. Similar effects of colchicine on glycoprotein migration were reported earlier for human jejunal biopsies in culture (Blok *et al.*, 1981) and for rat small intestine (Ellinger *et al.*, 1983).

The effect of polyamine deficiency on Golgi apparatus membranes and galactosyltransferase activity in mouse small intestinal epithelial cells was studied by Sakamaki *et al.* (1989). They produced polyamine-deficient cells by injecting two inhibitors of polyamine synthesis, ethylglyoxal bis(guanylhydrazone) and α -difluoromethylornithine into mice. Polyamine deficiency produced swelling of the Golgi apparatus membranes (demonstrated by electron microscopy) accompanied by a decrease (to approximately 55% of the control value) in galactosyltransferase activity. These results suggested that galactosyltransferase activity is diminished in swollen Golgi apparatus membranes.

Umesaki and Ohara (1989) investigated in detail treatments which lead to an increase in GDP-fucose : asialo $G_{M1}\alpha(1-2)$ fucosyltransferase activity in rat small intestinal mucosa. The increase in this particular fucosyltransferase activity was manifested by alteration in the neutral glycolipids of the microvillar plasma membrane. Factors shown to cause an increase in fucosyltransferase activity were microbial contamination of germ-free mice, weaning (see Section IV,A,2), intraperitoneal injection of the protein synthesis inhibitors cycloheximide or emetine (although repeated injection of cycloheximide every 2 hr resulted in a repression of fucosyltransferase activity), injection of a soluble fraction from a small intestinal homogenate, and mechanical injury to the intestinal mucosa. They also analyzed the composition of the glycolipids in mucosal fractions after such treatments and found an increase in their fucose content. Finally, by separating crypt from villus cells, they found that fucosyltransferase activity was increased in villus cells as compared to crypt cells. They attributed these findings to indicate that the increase in fucosyltransferase activity in response to various stimuli is preferentially localized to the postmitotic epithelial cells located on the villus.

VI. Differentiation and Glycosylation in Intestinal Cell Culture Systems

Although the morphology and physiology of the intestinal tract are quite amenable for studying differentiation events (Section I), pitfalls of using such an

organ system in biochemical studies are numerous, i.e., obtaining pure cell populations, experimental manipulation of cells, and difficulty in administering exogenous agents, to name a few. For these reasons, alternative experimental systems such as intestinal organ (Quaroni, 1985) and cell culture (Rousset, 1986) have been introduced. The recent introduction of several stable cell lines derived from intestinal epithelial cells has made this a particularly fruitful avenue of research.

The oligosaccharide composition of cell surface glycopeptides was investigated in confluent and subconfluent cultures of the rat small intestinal epithelial cell line IEC-6 by measuring the incorporation of D-[2-³H] mannose and by glycopeptide sensitivity to various oligosaccharide processing enzymes (Sasak *et al.*, 1982). They found that confluent cells contained a much higher proportion of complex oligosaccharides in glycopeptides of the plasma membrane than did subconfluent cells. Only minor differences were observed between total mannose-labeled glycopeptides from confluent and subconfluent cultures, suggesting that the cell surface changes were mainly due to differences in biosynthesis of the carbohydrate moieties and not to the formation of different glycoproteins. Moreover, this alteration in oligosaccharide composition of cell surface glycopeptides was shown to be dependent upon cell density and not on the growth rate of the cells. Interestingly, Sasak *et al.* (1982) also were able to draw a correlation between degree of cell adhesion to the substratum and cell surface oligosaccharides: confluent cultures containing cell surface glycopeptides with complex-type oligosaccharide structures were more adherent than their subconfluent counterparts displaying more high mannose-type oligosaccharides.

Several recent reports have documented the relationship between cell differentiation and the extent of processing of N-linked oligosaccharides in the human colon cancer cell line HT-29 (Trugnan *et al.*, 1987; Ogier-Denis *et al.*, 1988, 1989). HT-29 cells remain undifferentiated in media containing glucose, but undergo differentiation when glucose is removed from the media. Trugnan *et al.* (1987) examined the biosynthesis of sucrase-isomaltase, a microvillar membrane protein taken as a marker for differentiated intestinal epithelial cells *in vivo*, in both differentiated and undifferentiated HT-29 cells. In contrast to the normal processing and expression of this enzyme at the cell surface in differentiated HT-29 cells, in undifferentiated cells no enzyme was detectable at the plasma membrane. They showed that the failure to detect membrane expression was not due to lack of synthesis, but rather to abnormal posttranslational processing. Indeed, as compared to the enzyme synthesized and expressed in differentiated HT-29 cells, sucrase-isomaltase produced in the undifferentiated cells displayed (1) an impairment of the conversion from high mannose to complex form of the enzyme; (2) abnormal complex form glycosylation; and (3) rapid intracellular degradation of both high mannose-type and complex-type enzymes. In a subsequent paper (Ogier-Denis *et al.*, 1988), this group investigated

whether the impairment in glycosylation noted in undifferentiated HT-29 cells was specific for sucrase-isomaltase, or a general glycosylation defect. They found that there is an overall defect in the processing of N-linked oligosaccharides (Section II) which is manifested by alterations in three processing steps: (1) incorporation of D-[2-³H]mannose into glycoproteins; (2) conversion of high-mannose chains to complex-type N-linked glycans; and (3) trimming of high-mannose chains at the level of conversion of Man₆₋₈-GlcNAc₂-Asn to Man₇-GlcNAc₂-Asn. This particular trimming reaction was elaborated on in another report (Ogier-Denis *et al.*, 1989), where it was suggested that it may represent an important regulatory point in the conversion of undifferentiated to differentiated cells. These results, therefore, suggest that there is an impairment in the conversion of high mannose forms of N-linked oligosaccharides into complex-type in undifferentiated HT-29 cells. Future investigations on these cultured intestinal cells should help to unravel in more detail the cellular mechanisms involved in terminal differentiation as it relates to glycosylation.

VII. Concluding Remarks

Although much effort has been directed toward elucidating glycosylation mechanisms and patterns in intestinal cells, unequivocal answers have not been forthcoming. This lack of emergence of a unifying concept underlying intestinal cell glycosylation may be the result of many divergent factors. Conflicting results concerning the activities of glycosyltransferases in intestinal homogenates almost certainly results from variation in methodologies; i.e., (1) mucosal scrapings representing mostly epithelial cells versus homogenates containing submucosa and lamina propria; (2) failure to allow for endogenous intestinal enzymes which could potentially degrade glycosyltransferases; (3) variation in acceptor substrates employed, resulting in the measurement of different glycosyltransferases within the same class; and (4) different techniques for the separation of crypt versus villus epithelial cells. Similar technique-related problems could explain the variation in expression of intestinal carbohydrates. However, this is more likely due to the inherent variability in glycosylation expressed in a given cell type. Many detailed investigations have revealed a marked degree of glycoconjugate heterogeneity, not only among similar cell types from different species (Holthofer, 1983; Schulte and Spicer, 1983a,b; Spicer *et al.*, 1987), but also among supposedly homogeneous cell populations within a given organ (Watanabe *et al.*, 1981; Spicer *et al.*, 1981; LeHir *et al.*, 1982; Roth *et al.*, 1983; Brown *et al.*, 1985; Roth and Taatjes, 1985; Roth *et al.*, 1988b; Taatjes *et al.*, 1988b). Such heterogeneity may reflect blood group specificities, environmental or genetic variation, differentiation state of the cell, or pathological influences. However, a rapidly emerging concept suggests that the glycoconjugate repertoire displayed

by a given cell reflects its endogenous expression of glycosyltransferases. This concept has recently been discussed in detail by Paulson (1989; Paulson *et al.*, 1989) and by Rademacher *et al.* (1988), and will not be elaborated on here. Given the role played by terminal oligosaccharide structures in cell-cell recognition phenomena (Section I), the expression of glycosyltransferases would appear to occupy a key position in the posttranslational processing of glycoconjugates and thus influence cellular functions. Does this then mean that the carbohydrate portion of all types of glycoconjugates is important for their biological functioning? Certainly this is not the case for all glycoconjugates, and is an important area of concern in biotechnology. The importance of glycosylation in intestinal systems is mostly unknown at this point, although the well-documented shift from sialylation to fucosylation during rat postnatal development (Sections IV,A,2,4, and 6) has been attributed to represent the change in physiological functioning of the intestine during the weaning phase (Torres-Pinedo and Mahmood, 1984). It seems probable that the application of cDNA probes for various glycosyltransferases to intestinal systems (Paulson *et al.*, 1989) as well as the development of chimeric and transgenic mice (Gordon, 1989; Trahair *et al.*, 1989) will provide exciting opportunities in the future for the investigation of the importance of intestinal glycosylation in a myriad of functions.

ACKNOWLEDGMENTS

The original research described in this paper has received generous continual support from the Swiss National Science Foundation. We would like to thank Daniel Wey, Michele von Turkovitch, and Linda Barcomb for preparing the figures and photographs.

REFERENCES

- Abeijon, C., and Hirschberg, C. B. (1987). *J. Biol. Chem.* **262**, 4153-4159.
- Andrews, P. (1970). *FEBS Lett.* **9**, 297-300.
- Aub, J. C., Tieslau, C., and Lankester, A. (1963). *Proc. Natl. Acad. Sci. U.S.A.* **50**, 613-619.
- Aub, J. C., Sanford, B. H., and Cote, M. N. (1965a). *Proc. Natl. Acad. Sci. U.S.A.* **54**, 396-399.
- Aub, J. C., Sanford, B. H., and Wang, L. (1965b). *Proc. Natl. Acad. Sci. U.S.A.* **54**, 400-402.
- Balsamo, J., Pratt, R. S., Emmerling, M. R., Grunwald, G. B., and Lilien, J. (1986). *J. Cell Biochem.* **32**, 125-141.
- Barker, R., Olsen, K. W., Shaper, J. H., and Hill, R. L. (1972). *J. Biol. Chem.* **247**, 7135-7147.
- Bayna, E. M., Shaper, J. H., and Shur, B. D. (1988). *Cell* **53**, 145-157.
- Bendayan, M. (1984). *J. Electron Microsc. Tech.* **1**, 243-270.
- Bennett, G., Haddad, A., and Leblond, C. P. (1987). *J. Histochem. Cytochem.* **35**, 861-864.
- Berger, E. G., and Hesford, F. (1985). *Proc. Natl. Acad. Sci. U.S.A.* **82**, 4736-4739.
- Berger, E. G., Thurnher, M., and Muller, U. (1987). *Exp. Cell Res.* **173**, 267-273.
- Berlin, J. D. (1967). *J. Cell Biol.* **32**, 760-766.
- Blok, J., Ginsel, L. A., Mulder-Stapel, A. A., Onderwater, J. J. M., and Daems, W. T. (1981). *Cell Tissue Res.* **215**, 1-12.
- Boland, C. R., and Kim, Y. S. (1984). In "Markers of Colonic Cell Differentiation" (S. R. Wolman and A. J. Mastromarino, eds.), pp. 253-266. Raven, New York.

- Boyle, F., Snape, S., Duane, P., Cook, N., and Peters, T. (1986). *Biosci. Rep.* **6**, 171–175.
- Bresalier, R. S., Boland, C. R., and Kim, Y. S. (1985). *J. Natl. Cancer Inst.* **75**, 249–259.
- Brown, D., Roth, J., and Orci, L. (1985). *Am. J. Physiol.* **248**, C348–C356.
- Buller, H. A., Rings, E. H. H. M., Pajkrt, D., Montgomery, R. K., and Grand, R. J. (1990). *Gastroenterology* **98**, 667–675.
- Burger, M. M., and Goldberg, A. R. (1967). *Proc. Natl. Acad. Sci. U.S.A.* **57**, 359–366.
- Caldero, J., Campo, E., Calomarde, X., and Torra, M. (1988). *Histochemistry* **90**, 261–270.
- Carlemalm, E., Garavito, M., and Villiger, W. (1982). *J. Microsc. (Oxford)* **126**, 123–143.
- Chang, W. W. L., and Leblond, C. P. (1971). *Am. J. Anat.* **131**, 73–100.
- Cheng, H. (1974). *Am. J. Anat.* **141**, 481–502.
- Cheng, H., and Leblond, C. P. (1974). *Am. J. Anat.* **141**, 537–562.
- Childs, R. A., Berger, E. G., Thorpe, S. J., Aegerter, E., and Feizi, T. (1986). *Biochem. J.* **238**, 605–611.
- Chu, S.-h. W., and Walker, W. A. (1986). *Biochim. Biophys. Acta* **883**, 496–500.
- Chu, S.-h. W., Carter, E. A., Tompkins, R. G., and Burke, J. F. (1988). *Biochem. Biophys. Res. Commun.* **153**, 377–381.
- Colley, K. J., Lee, E. U., Adler, B., Browne, J. K., and Paulson, J. C. (1989). *J. Biol. Chem.* **264**, 17619–17622.
- D'Agostaro, G., Bendiak, B., and Tropak, M. (1989). *Eur. J. Biochem.* **183**, 211–217.
- Dahiya, R., Ahlawat, R. S., and Sharma, A. (1989). *Biochem. Cell Biol.* **67**, 42–47.
- Davis, B. W., Berger, E. G., Locher, G. W., Zeller, M., and Goldhirsch, A. (1984). *J. Histochem. Cytochem.* **32**, 92–96.
- Deschuyteneer, M., Eckhardt, A. E., Roth, J., and Hill, R. L. (1988). *J. Biol. Chem.* **263**, 2452–2459.
- Dudeja, P. K., Dahiya, R., Brown, M. D., and Brasitus, T. A. (1988). *Biochem. J.* **253**, 401–408.
- Dunphy, W. G., and Rothman, J. E. (1983). *J. Cell Biol.* **97**, 270–275.
- Dunphy, W. G., and Rothman, J. E. (1985). *Cell* **42**, 13–21.
- Dunphy, W. G., Fries, E., Urbani, L. J., and Rothman, J. E. (1981). *Proc. Natl. Acad. Sci. U.S.A.* **78**, 7453–7457.
- Dunphy, W. G., Brands, R., and Rothman, J. E. (1985). *Cell* **40**, 463–472.
- Eastwood, G. L. (1977). *Gastroenterology* **72**, 962–975.
- Egea, G., Goldstein, I. J., and Roth, J. (1989). *Histochemistry* **92**, 515–522.
- Elhammer, A., and Kornfeld, S. (1984). *J. Cell Biol.* **98**, 327–331.
- Ellinger, A., and Pavelka, M. (1985). *Histochem. J.* **17**, 1321–1336.
- Ellinger, A., and Pavelka, M. (1988a). *Eur. J. Cell Biol.* **47**, 62–71.
- Ellinger, A., and Pavelka, M. (1988b). In "Lectins: Biology, Biochemistry, Clinical Biochemistry" (T. C. Bog-Hansen and D. L. J. Freed, eds.), Vol. 6, pp. 709–714. Sigma Chem. Co., St. Louis, Missouri.
- Ellinger, A., Pavelka, M., and Gangl, A. (1983). *J. Ultrastruct. Res.* **85**, 260–271.
- Essner, E., Schreiber, J., and Griewski, R. A. (1978). *J. Histochem. Cytochem.* **26**, 452–458.
- Etzler, M. E., and Branstrator, M. L. (1974). *J. Cell Biol.* **62**, 329–343.
- Etzler, M. E., and Branstrator, M. L. (1979). *Ciba Found. Symp.* No.70, 51–68.
- Farquhar, M. G. (1985). *Annu. Rev. Cell Biol.* **1**, 447–488.
- Faulk, W. P., and Taylor, G. M. (1971). *Immunochemistry* **8**, 1081–1083.
- Feizi, T., and Childs, R. A. (1987). *Biochem. J.* **245**, 1–11.
- Freeman, F. J., Kim, Y., and Kim, Y. S. (1978). *Cancer Res.* **28**, 3385–3390.
- Fujita-Yamaguchi, Y., and Yoshida, A. (1981). *J. Biol. Chem.* **256**, 2701–2706.
- Geuze, H. J., Slot, J. W., Strous, G. J. A. M., Hasilik, A., and von Figura, K. (1985). *J. Cell Biol.* **101**, 2253–2262.
- Goldberg, D. E., and Kornfeld, S. (1983). *J. Biol. Chem.* **258**, 3159–3165.
- Goldstein, I. J., and Poretz, R. D. (1986). In "The Lectins: Properties, Functions, and Applications in Biology and Medicine" (I. E. Liener, N. Sharon, and I. J. Goldstein, eds.), pp. 33–248. Academic Press, Orlando, Florida.

- Gordon, J. I. (1989). *J. Cell Biol.* **108**, 1187–1194.
- Gorelick, F. S., Sarras, M. P., and Jamieson, J. D. (1982). *J. Histochem. Cytochem.* **30**, 1097–1108.
- Green, E. D., Adelt, G., Baenziger, J. U., Wilson, S., and Van Halbeek, H. (1988). *J. Biol. Chem.* **263**, 18253–18268.
- Griffiths, G., and Simons, K. (1986). *Science* **234**, 438–443.
- Hagopian, A., and Eylar, E. H. (1968). *Arch. Biochem. Biophys.* **128**, 422–433.
- Hagopian, H. B., Bosman, B. H., and Eylar, E. H. (1968). *Arch. Biochem. Biophys.* **128**, 387–396.
- Hanover, J. A., and Lennarz, W. J. (1981). *Arch. Biochem. Biophys.* **211**, 1–19.
- Hanover, J. A., Lennarz, W. J., and Young, J. D. (1980). *J. Biol. Chem.* **255**, 6713–6716.
- Hart, G. W., Holt, G. D., and Haltiwanger, R. S. (1988). *Trends Biochem. Sci.* **13**, 380–384.
- Hart, G. W., Haltiwanger, R. S., Holt, G. D., and Kelley, W. G. (1989). *Annu. Rev. Biochem.* **58**, 841–874.
- Hedman, K., Pastan, I., and Willingham, M. C. (1986). *J. Histochem. Cytochem.* **34**, 1069–1077.
- Herscovics, A., Bugge, B., Quaroni, A., and Kirsch, K. (1980). *Biochem. J.* **192**, 145–153.
- Hirschberg, C. B., and Snider, M. D. (1987). *Annu. Rev. Biochem.* **56**, 63–87.
- Holthofer, H. (1983). *J. Histochem. Cytochem.* **31**, 531–537.
- Hubbard, S. C., and Ivatt, R. J. (1981). *Annu. Rev. Biochem.* **50**, 555–583.
- Hudgin, R. L., and Schachter, H. (1971). *Can. J. Biochem.* **49**, 829–837.
- Hugon, J. S., Bennett, G., Pothier, P., and Ngoma, Z. (1987). *Cell Tissue Res.* **248**, 653–662.
- Jaswal, V. M. S., Babbar, H. S., and Mahmood, A. (1988). *Biochem. Med. Methods Biol.* **39**, 105–110.
- Kaplan, H. A., Woloski, B. M. R. N. J., Hellman, M., and Jamieson, J. C. (1983). *J. Biol. Chem.* **258**, 11505–11509.
- Kim, Y. S. (1989a). In "Modern Concepts in Gastroenterology" (E. Shaffer, N. Williams, and A. B. R. Thomson, eds.), Vol. 2, pp. 197–208. Raven, New York.
- Kim, Y. S. (1989b). *Gastroenterol. Int.* **2**, 101–106.
- Kim, Y. S., and Perdomo, J. M. (1974). *FEBS Lett.* **44**, 309–312.
- Kim, Y. S., Perdomo, J., and Nordberg, J. (1971). *J. Biol. Chem.* **246**, 5466–5476.
- Kim, Y. S., Perdomo, J., Ochoa, P., and Isaacs, R. A. (1975). *Biochim. Biophys. Acta* **391**, 39–50.
- Kocourek, J. (1986). In "The Lectins: Properties, Functions, and Applications in Biology and Medicine" (I. E. Liener, N. Sharon, and I. J. Goldstein, eds.), pp. 1–32. Academic Press, Orlando, Florida.
- Kolinska, J., Ivanov, S., and Chelibonova-Lorer, H. (1988). *FEBS Lett.* **242**, 57–60.
- Kornfeld, R., and Kornfeld, S. (1985). *Annu. Rev. Biochem.* **54**, 631–664.
- LaMont, J. T., and Ventola, A. (1978). *Am. J. Physiol.* **235**, E213–E217.
- Lau, J. T. Y., and Carlson, D. M. (1981). *J. Biol. Chem.* **256**, 7142–7145.
- Leblond, C. P., and Messier, B. (1958). *Anat. Rec.* **132**, 247–259.
- Lee, E. U., Roth, J., and Paulson, J. C. (1989). *J. Biol. Chem.* **264**, 13848–13855.
- LeHir, M., Kaissling, B., Koeppen, B. M., and Wade, J. B. (1982). *Am. J. Physiol.* **242**, C117–C129.
- Lopez, L. C., Maillet, C. M., Oleszkowicz, K., and Shur, B. D. (1989). *Mol. Cell. Biol.* **9**, 2370–2377.
- Lucocq, J. M., Brada, D., and Roth, J. (1986). *J. Cell Biol.* **102**, 2137–2146.
- Lucocq, J. M., Berger, E. G., and Roth, J. (1987). *J. Histochem. Cytochem.* **35**, 67–74.
- Mahmood, A., and Torres-Pinedo, R. (1983). *Biochem. Biophys. Res. Commun.* **113**, 400–406.
- Mahmood, A., and Torres-Pinedo, R. (1985). *Pediatr. Res.* **19**, 899–902.
- Masibay, A. S., and Qasba, P. K. (1989). *Proc. Natl. Acad. Sci. U.S.A.* **86**, 5733–5737.
- Masri, K. A., Appert, H. E., and Fukuda, M. N. (1988). *Biochem. Biophys. Res. Commun.* **157**, 657–663.
- Mookerjee, S., Marshall, J. W., and Collins, J. M. (1977). *Biochem. Biophys. Res. Commun.* **78**, 309–316.

- Moremen, K., and Touster, O. (1988). In "Protein Transfer and Organelle Biosynthesis" (R. C. Das and P. W. Robbins, eds.), pp. 209–240. Academic Press, San Diego, California.
- Morita, A., Miura, S., Erickson, R. H., Sleisenger, M. H., and Kim, Y. S. (1986). *Biochim. Biophys. Acta* **883**, 506–516.
- Murata, F., Suganuma, T., Tsuyama, S., Ishida, K., and Funasako, S. (1986). *J. Electron Microsc. 35*, 29–37.
- Nakazawa, K., Ando, T., Kimura, T., and Narimatsu, H. (1988). *Biochem. Biophys. Res. Commun.* **104**, 165–168.
- Narimatsu, H., Sinha, S., Brew, K., Okayama, H., and Qasba, P. K. (1986). *Proc. Natl. Acad. Sci. U.S.A.* **83**, 4720–4724.
- Neefjes, J. J., Verkerk, J. M. H., Broxterman, H. J. G., van der Marel, G. A., van Boom, J. H., and Ploegh, H. L. (1988). *J. Cell Biol.* **107**, 79–87.
- Neutra, M., and Leblond, C. P. (1966a). *J. Cell Biol.* **30**, 119–136.
- Neutra, M., and Leblond, C. P. (1966b). *J. Cell Biol.* **30**, 137–150.
- Ogier-Denis, E., Codogno, P., Chantret, I., and Trugnan, G. (1988). *J. Biol. Chem.* **263**, 6031–6037.
- Ogier-Denis, E., Bauvy, C., Aubery, M., Codogno, P., Sapin, C., Rousset, M., Zweibaum, A., and Trugnan, G. (1989). *J. Cell. Biochem.* **41**, 13–23.
- Orci, L., Ravazzola, M., Amherdt, M., Brown, D., and Perrelet, A. (1986). *EMBO J.* **5**, 2097–2101.
- Ornftoft, T. F., Greenwell, P., and Watkins, W. M. (1987). *Glycoconjugates, Proc. Int. Symp. 9th, Lille, Fr. Abstr. E* 108.
- Ovtscharoff, W., and Ichev, K. (1984). *Acta Histochem.* **74**, 21–24.
- Ozaki, C. K., Chu, S.-h. W., and Walker, W. A. (1989). *Biochim. Biophys. Acta* **991**, 243–247.
- Paulson, J. C. (1985). In "The Receptors" (P. M. Conn, ed.), Vol. 2, pp. 131–219. Academic Press, New York.
- Paulson, J. C. (1989). *Trends Biochem. Sci.* **14**, 272–276.
- Paulson, J. C., Beranek, W. E., and Hill, R. L. (1977). *J. Biol. Chem.* **252**, 2356–2362.
- Paulson, J. C., Weinstein, J., and Schauer, A. (1989). *J. Biol. Chem.* **264**, 10931–10934.
- Pavelka, M. (1987). *Adv. Anat. Embryol. Cell Biol.* **106**, 1–94.
- Pavelka, M., and Ellinger, A. (1985). *J. Histochem. Cytochem.* **33**, 905–914.
- Pavelka, M., and Ellinger, A. (1986). *Eur. J. Cell Biol.* **41**, 270–278.
- Pavelka, M., and Ellinger, A. (1989a). *J. Histochem. Cytochem.* **37**, 877–884.
- Pavelka, M., and Ellinger, A. (1989b). In "Electron Microscopy of Subcellular Dynamics" (H. Plattner, ed.), pp. 199–218. CRC Press, Boca Raton, Florida.
- Pestalozzi, D. M., Hess, M., and Berger, E. G. (1982). *J. Histochem. Cytochem.* **30**, 1146–1152.
- Pierce, M., Turley, E. A., and Roth, S. (1980). *Int. Rev. Cytol.* **65**, 1–47.
- Potten, C. S., and Loeffler, M. (1987). *J. Theor. Biol.* **127**, 381–391.
- Quaroni, A. (1985). *J. Cell Biol.* **100**, 1611–1622.
- Quaroni, A., Kirsch, K., Herscovics, A., and Isselbacher, K. J. (1980). *Biochem. J.* **192**, 133–144.
- Rademacher, T. W., Parekh, R. B., and Dwek, R. A. (1988). *Annu. Rev. Biochem.* **57**, 785–838.
- Rambourg, A., and Clermont, Y. (1990). *Eur. J. Cell Biol.* **51**, 189–200.
- Rambourg, A., Hernandez, W., and Leblond, C. P. (1969). *J. Cell Biol.* **40**, 395–414.
- Rampal, P. J., LaMont, J. T., and Trier, J. S. (1978). *Am. J. Physiol.* **235**, E207–E212.
- Ratnam, S., Nagpukur, A., and Mookerjee, S. (1987). *Biochem. Cell Biol.* **65**, 183–187.
- Reichner, J. S., Whiteheart, S. W., and Hart, G. W. (1988). *J. Biol. Chem.* **263**, 16316–16326.
- Revel, J. P. (1964). *J. Microsc. (Paris)* **3**, 535–544.
- Roseman, S. (1970). *Chem. Phys. Lipids* **5**, 270–297.
- Roth, J. (1978). *Exp. Pathol., Suppl.* No.3. Fischer, Jena, Germany.
- Roth, J. (1983a). In "Techniques in Immunocytochemistry" (G. R. Bullock and P. Petrusz, eds.), Vol. 2, pp. 217–284. Academic Press, London.
- Roth, J. (1983b). *J. Histochem. Cytochem.* **31**, 987–999.

- Roth, J. (1984). *J. Cell Biol.* **98**, 399–406.
- Roth, J. (1986). *J. Microsc. (Oxford)* **143**, 125–137.
- Roth, J. (1987a). *Biochim. Biophys. Acta* **906**, 405–436.
- Roth, J. (1987b). *Scanning Microsc.* **1**, 695–704.
- Roth, J. (1989). *Methods Cell Biol.* **31**, 513–551.
- Roth, J., and Berger, E. G. (1982). *J. Cell Biol.* **92**, 223–229.
- Roth, J., and Taatjes, D. J. (1985). *Eur. J. Cell Biol.* **39**, 449–457.
- Roth, J., and Taatjes, D. J. (1989). In "Electron Microscopy of Subcellular Dynamics" (H. Plattner, ed.), pp. 219–237. CRC Press, Boca Raton, Florida.
- Roth, J., Bendayan, M., and Orci, L. (1978). *J. Histochem. Cytochem.* **26**, 1074–1081.
- Roth, J., Brown, D., and Orci, L. (1983). *J. Cell Biol.* **96**, 1189–1196.
- Roth, J., Lucocq, J. M., and Charest, P. M. (1984). *J. Histochem. Cytochem.* **32**, 1167–1176.
- Roth, J., Taatjes, D. J., Lucocq, J. M., Weinstein, J., and Paulson, J. C. (1985a). *Cell* **43**, 287–295.
- Roth, J., Lentze, M. J., and Berger, E. G. (1985b). *J. Cell Biol.* **100**, 118–125.
- Roth, J., Taatjes, D. J., Weinstein, J., Paulson, J. C., Greenwell, P., and Watkins, W. M. (1986). *J. Biol. Chem.* **261**, 14307–14312.
- Roth, J., Greenwell, P., and Watkins, W. M. (1987). *Biochem. Soc. Trans.* **15**, 599–601.
- Roth, J., Lucocq, J. M., and Taatjes, D. J. (1988a). *Acta Histochem., Suppl.* **36**, 81–99.
- Roth, J., Taatjes, D. J., Lucocq, J. M., and Charest, P. M. (1988b). *Acta Histochem., Suppl.* **36**, 125–140.
- Roth, J., Greenwell, P., and Watkins, W. M. (1988c). *Eur. J. Cell Biol.* **46**, 105–112.
- Rousset, M. (1986). *Biochimie* **68**, 1035–1040.
- Sakamaki, Y., Terao, K., Ito, K., Kashiwagi, K., and Igarashi, K. (1989). *Biochem. Pharmacol.* **38**, 1083–1089.
- Saraste, J., and Kuismanen, E. (1984). *Cell* **38**, 535–549.
- Sasak, W., Herscovics, A., and Quaroni, A. (1982). *Biochem. J.* **201**, 359–366.
- Sata, T., Lackie, P. M., Taatjes, D. J., Peumans, W., and Roth, J. (1989). *J. Histochem. Cytochem.* **37**, 1577–1588.
- Schulte, B. A., and Spicer, S. S. (1983a). *J. Histochem. Cytochem.* **31**, 391–403.
- Schulte, B. A., and Spicer, S. S. (1983b). *Am. J. Anat.* **168**, 345–362.
- Shaper, N. L., Mann, P. L., and Shaper, J. H. (1985). *J. Cell. Biochem.* **28**, 229–239.
- Shaper, N. L., Shaper, J. H., Meuth, J. L., Fox, J. L., Chang, H., Kirsch, I., and Hollis, G. (1986). *Proc. Natl. Acad. Sci. U.S.A.* **83**, 1573–1577.
- Shaper, N. L., Hollis, G. F., Douglas, J. G., Kirsch, I. R., and Shaper, J. H. (1988). *J. Biol. Chem.* **263**, 10420–10428.
- Sharon, N., and Lis, H. (1989). *Science* **246**, 227–234.
- Shur, B. D. (1989). *Biochim. Biophys. Acta* **988**, 389–409.
- Singer, S. J., and Nicolson, G. L. (1972). *Science* **175**, 720–731.
- Snider, M. D., and Rogers, O. C. (1985). *J. Cell Biol.* **100**, 826–834.
- Snider, M. C., and Rogers, O. C. (1986). *J. Cell Biol.* **103**, 265–275.
- Spicer, S. S., Baron, D. A., Sato, A., and Schulte, B. A. (1981). *J. Histochem. Cytochem.* **29**, 994–1002.
- Spicer, S. S., Erlandsen, S. L., Wilson, A. C., Hammer, M. F., Hennigar, R. A., and Schulte, B. A. (1987). *J. Histochem. Cytochem.* **35**, 1231–1244.
- Srivastava, O. P., Steele, M. I., and Torres-Pinedo, R. (1987). *Biochim. Biophys. Acta* **914**, 143–151.
- Strous, G. J. A. M. (1979). *Proc. Natl. Acad. Sci. U.S.A.* **76**, 2691–2698.
- Strous, G. J. A. M. (1986). *CRC Crit. Rev. Biochem.* **21**, 119–151.
- Taatjes, D. J., and Roth, J. (1986). *Eur. J. Cell Biol.* **42**, 344–350.
- Taatjes, D. J., and Roth, J. (1988). *Eur. J. Cell Biol.* **46**, 289–298.
- Taatjes, D. J., and Roth, J. (1990). *Eur. J. Cell Biol.* **53**, 255–266.

- Taatjes, D. J., Roth, J., Weinstein, J., Paulson, J. C., Shaper, N. L., and Shaper, J. H. (1987). *Eur. J. Cell Biol.* **44**, 187–194.
- Taatjes, D. J., Roth, J., Weinstein, J., and Paulson, J. C. (1988a). *J. Biol. Chem.* **263**, 6302–6309.
- Taatjes, D. J., Roth, J., Peumans, W., and Goldstein, I. J. (1988b). *Histochem. J.* **20**, 478–490.
- Thorens, B., and Vassalli, P. (1986). *Nature (London)* **321**, 618–620.
- Tooze, S. A., Tooze, J., and Warren, G. (1988). *J. Cell Biol.* **106**, 1475–1487.
- Torres, C.-R., and Hart, G. W. (1984). *J. Biol. Chem.* **261**, 3308–3317.
- Torres-Pinedo, R., and Mahmood, A. (1984). *Biochem. Biophys. Res. Commun.* **125**, 546–553.
- Trahair, J. F., Neutra, M. R., and Gordon, J. I. (1989). *J. Cell Biol.* **109**, 3231–3242.
- Trugnan, G., Rousset, M., Chantret, I., Barbat, A., and Zweibaum, A. (1987). *J. Cell Biol.* **104**, 1199–1205.
- Tsuyama, S., Suganuma, T., Ihida, K., and Murata, F. (1986). *Acta Histochem. Cytochem.* **19**, 555–565.
- Ulrich, J. T., Schenck, J. R., Rittenhouse, H. G., Shaper, N. L., and Shaper, J. H. (1986). *J. Biol. Chem.* **261**, 7975–7981.
- Umesaki, Y., and Ohara, M. (1989). *Biochim. Biophys. Acta* **1001**, 163–168.
- Van Halbeek, H., Gerwig, G. J., Vliegenthart, J. F. G., Smits, H. L., van Kerkof, P. J. M., and Kramer, J. F. (1983). *Biochim. Biophys. Acta* **737**, 107–116.
- Watanabe, M., Muramatsu, T., Shirane, H., and Ugai, K. (1981). *J. Histochem. Cytochem.* **29**, 779–790.
- Weinstein, J., de Souza-e-Silva, U., and Paulson, J. C. (1982). *J. Biol. Chem.* **257**, 13835–13844.
- Weinstein, J., Lee, E. U., McEntee, K., Lai, P., and Paulson, J. C. (1987). *J. Biol. Chem.* **262**, 17735–17743.
- Weiser, M. M. (1973a). *J. Biol. Chem.* **248**, 2536–2541.
- Weiser, M. M. (1973b). *J. Biol. Chem.* **248**, 2542–2548.
- Weiser, M. M., Neumeier, M. M., Quaroni, A., and Kirsch, K. (1978). *J. Cell Biol.* **77**, 722–734.
- Weiser, M. M., Walters, J. R. F., and Wilson, J. R. (1986). *Int. Rev. Cytol.* **101**, 1–57.
- Weiser, M. M., Majumdar, S., Wilson, J. R., and Luther, R. (1987). *Biochim. Biophys. Acta* **924**, 323–331.
- Wetzel, M. G., Wetzel, B. K., and Spicer, S. S. (1966). *J. Cell Biol.* **30**, 299–315.
- Wilson, J. R., Deinhart, J. A., and Weiser, M. M. (1987). *Biochim. Biophys. Acta* **924**, 332–340.
- Yokoyama, M., Nishiyama, F., Kawai, N., and Hirano, H. (1980). *Exp. Cell Res.* **125**, 47–53.