

# Grayscale Marking of Anodized Aluminium Plate by Using Picosecond Laser and Galvanometer Scanner

Mindaugas GEDVILAS<sup>\*1</sup>, Bogdan VOISIAT<sup>\*1</sup> and Gediminas RAČIUKAITIS<sup>\*1</sup>

<sup>\*1</sup> Center for Physical Sciences and Technology, Savanoriu Ave. 231, LT-02300 Vilnius, Lithuania  
E-mail: [mgedvilas@ftmc.lt](mailto:mgedvilas@ftmc.lt)

In this work, we demonstrate the grayscale modifications of an anodized aluminium plate by using ultra-short laser pulses. The measurement and analysis results on influence of the laser marking process parameters on the blackness of marking obtained are presented. The study was conducted for the aluminium plate with the transparent anodizing  $\text{Al}_2\text{O}_3$  coating by using a commercially available industrial picosecond laser and galvanometer scanner. The grayscale of marking was changed by scanning the laser beam focused at the boundary of the coating and aluminium sheet without damaging the transparent coating. The scanning speed and mean laser power was varied in order to enhance the blackness of the marking.

It was determined experimentally how various process parameters, such as the laser power, pulse repetition rate, irradiation time per square millimetre affected the luminance  $Y'$  of the grayscale obtained. The grayscale modifications starting from 40 % grey (untreated sample) to 93 % grey were achieved without damaging the protective  $\text{Al}_2\text{O}_3$  coating.

DOI: 10.2961/jlmn.2014.03.0017

**Keywords:** Anodized aluminium, grayscale marking, picosecond laser, galvanometer scanner.

## 1. Introduction

Laser colour marking as a process has been known nearly for three decades [1]. It has a wide range of important applications like: the high precision variable information marking [2], authentication and traceability [3], creation of contemporary jewellery [4], decoration [5], selective colouring with 3D laser printing [6], electronics, the automotive industry, art for new designs and advertising [7]. Four main methods of laser colouring of metals have been reported in the literature. The first utilizes a laser as a heat source, which initiates formation of a transparent or semi-transparent oxide film on the metal surface [4, 8-12]. The change of the colour occurs via thin-film-interference phenomenon. This method has drawback as it is sensitive to processing parameters and is hard to reproduce [11, 13]. The second method is based on laser induced periodic surface structuring also called laser induced ripple formation [14-16]. Colour effect is obtained due to the diffraction of light by periodic structures on the metallic surface [17]. The third method is based on composition or structural changes of processed layer [18-20]. The fourth method is based on laser induced surface morphology changes on the substrate and light trapping by them [21]. All above mentioned methods are sensitive to wear and corrosion resistance because of the thinness of nano-structured surface [11]. The way to overcome this is to use metal with hard transparent coating and induce colour modification at the boundary of coating/metal without damaging the protective coating.

Aluminium is the most abundant metal in the Earth's crust and in the environment. It has many applications because of its unique chemical, electrical, thermal and mechanical properties [22]. Aluminium is very light and strong and its specific strength (strength-to-weight ratio) is just below stainless steel and titanium [23]. Moreover, it is

soft material and it is easy to machine [22]. However, softness makes it is easy to scratch. The anodizing aluminium by electrochemical procedure creates transparent  $\text{Al}_2\text{O}_3$  coating and makes the surface hardness comparable to sapphire depending on the thickness of the coating and anodizing procedure applied [24, 25].

In this work, the experimental results of the grayscale marking of anodized aluminium plate by using picosecond laser irradiation are presented. The various levels of grey were achieved at the  $\text{Al}_2\text{O}_3/\text{Al}$  interface by controlling the laser power, pulse repetition rate and processing time. The protective  $\text{Al}_2\text{O}_3$  was not removed during the laser processing.

## 2. Experimental

### 2.1 Experimental setup

Experimental setup with the picosecond laser and galvanometer scanner is shown in Fig. 1.

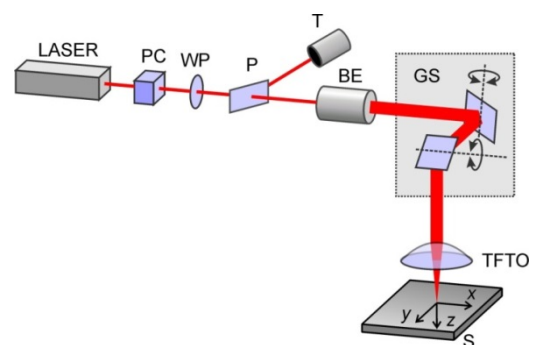

**Fig. 1** Principal scheme of experimental setup: LASER - picosecond laser, PC - Pockels cell, WP - half wavelength wave plate, P - polarizer, T - trap, BE - beam expander, GS - galvanometer scanner, TFTO - telecentric-f-theta objective, S - sample,  $xy$  - denotes beam positioning directions,  $z$  - beam propagation direction.

The diode pumped picosecond laser (PL10100, Ekspla) with the pulse duration of 10 ps, repetition rate of 50 - 200 kHz, wavelength of 1064 nm and laser power up to 1.0 W was used in the experiments. Laser beam path included electro-optical shutter, beam expander, galvanometer scanner (SCANgine14, ScanLab) with 80 mm telecentric-f-theta objective. The laser beam had Gaussian spatial distribution (Fig. 2).

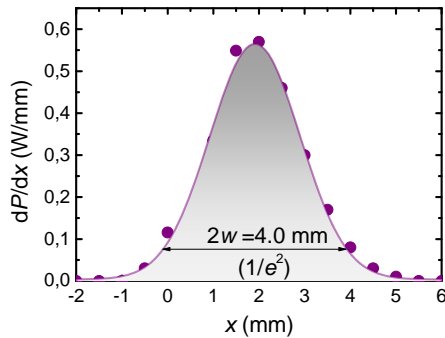

**Fig. 2** Gaussian beam profile measured by "knife edge" method at the entrance of the galvanometer scanner.

The beam diameter measured at the entrance of the galvanometer scanner was 4.0 mm ( $1/e^2$ ). Spot size on the sample was measured by using technique described by Liu [26] (Fig. 3).

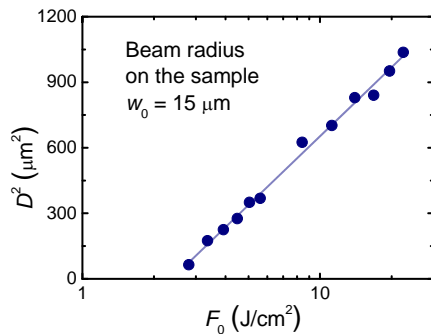

**Fig. 3** Modified diameter squared at the  $\text{Al}_2\text{O}_3/\text{Al}$  interface versus peak laser fluence.

Spot diameter on the sample at the  $\text{Al}_2\text{O}_3/\text{Al}$  interface was  $2w_0 = 30 \mu\text{m}$  ( $1/e^2$ ).

**2.2 Sample**

As a sample, the anodized aluminium plate with transparent  $\text{Al}_2\text{O}_3$  coating was used in the experiments. The thickness of Al plate was 1 mm and the thickness of  $\text{Al}_2\text{O}_3$  coating was 20  $\mu\text{m}$ .

**2.3 Tests**

Scanning of the Gaussian beam spot was performed perpendicular to the sample controlling the pitch (distance between laser spots same in both transverse directions  $x$  and  $y$ ) (Fig. 4a). The laser beam was focused on the  $\text{Al}_2\text{O}_3/\text{Al}$  interface passing the transparent  $\text{Al}_2\text{O}_3$  coating. The arrays of squares were marked on the sample (Fig. 4b). In one direction the pitch was changed from 1  $\mu\text{m}$  to 10  $\mu\text{m}$ , in other direction the laser power was changed from 0.1 W to 1.0 W. The area of each laser processed square was of  $2 \times 2 \text{ mm}^2$ .

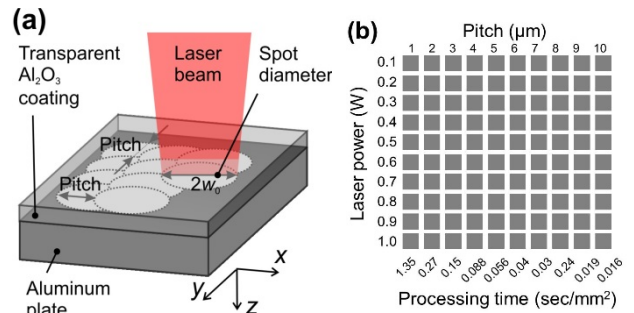

**Fig. 4** (a) schematic of the marking aluminium plate with transparent  $\text{Al}_2\text{O}_3$  coating processed by using picosecond laser beam being scanned with the same pitch in both directions  $x$  and  $y$ ;  $2w_0$  - is the laser spot diameter on the sample. (b) the array of squares marked on the sample by changing the processing parameters: pitch and laser power. The numbers below the columns of the squares represents the measured processing time of 1  $\text{mm}^2$  area at laser rep. rate of 100 kHz.

The arrays were repeated at three different repetition rates of 50 kHz, 100 kHz and 200 kHz. The processing time of each processed area was measured and plotted as a function of pitch (Fig. 5).

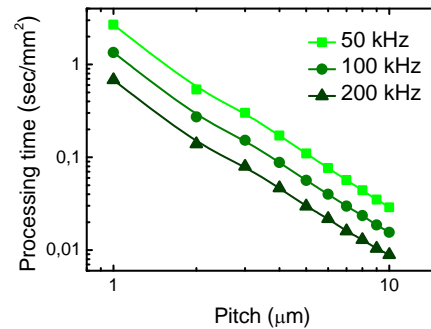

**Fig. 5** Processing time of 1  $\text{mm}^2$  area versus pitch at different laser repetition rates: (■) - 50 kHz; (●) - 100 kHz; (▲) - 200 kHz.

The processing time for laser repetition of 50 kHz was approximately two and four times higher than for 100 kHz and 200 kHz for the same pitch, respectively. The pitch was used only to describe the scanning procedure. The processing time was used instead of pitch.

**2.4 Evaluation of luminance of processed samples**

The RGB image was taken of each laser processed area by using optical microscope (Eclipse LV100, Nikon). The luminance  $Y'$  of grayscale was computed from RGB optical microscope images by using formula based on the NTSC standard [27]:

$$Y' = 0.299R + 0.587G + 0.114B. \quad (1)$$

The luminance  $Y'$  of eleven RGB grayscale images was calculated in order to evaluate the accuracy of Eq. (1) (Fig. 6)

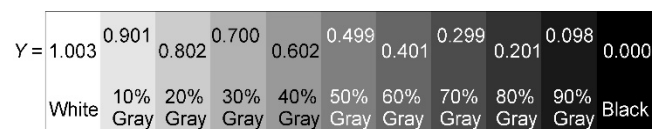

**Fig. 6** The luminance  $Y'$  of eleven RGB grayscale images calculated by using Eq. (1).

The luminance  $Y'$  calculations by using Eq. (1) give accuracy higher than 99.7 %.

### 3. Results and discussion

#### 3.1 Experimental grayscale marking of anodized aluminium

The digital camera (D5100, Nikon) images of the grayscale marked anodized aluminium plate by using the picosecond laser are shown in Fig. 7.

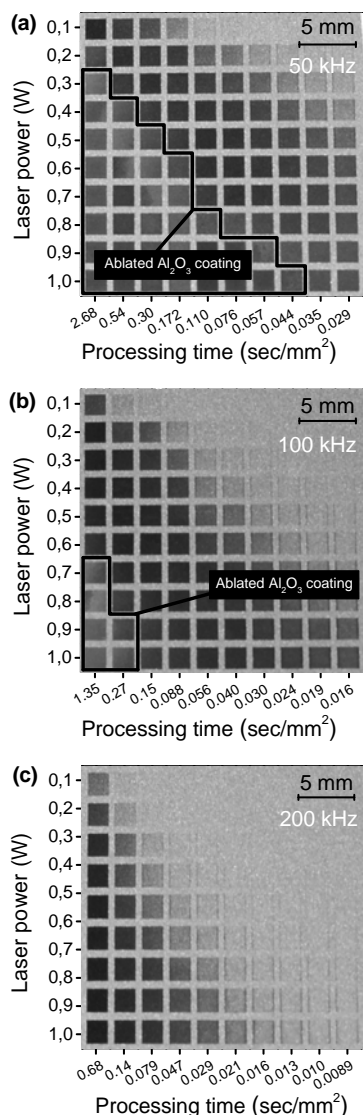

**Fig. 7** Digital camera images of array of tests performed of anodized aluminium sheet, in  $x$  direction processing time was changed,  $y$  direction laser power was changed. The area of each laser processed square was of  $2 \times 2 \text{ mm}^2$ . The squares of ablated  $\text{Al}_2\text{O}_3$  protective coating are indicated by black solid line. Laser repetition rate: (a) - 50 kHz; (b) - 100 kHz; (c) - 200 kHz.

The  $\text{Al}_2\text{O}_3$  was ablated when laser energy dose exceeded the ablation threshold. The processed squares with ablated  $\text{Al}_2\text{O}_3$  coating are marked by solid black line in Fig. 7. By using 50 kHz repetition rate, 34 % of the squares were marked with removal of the protective  $\text{Al}_2\text{O}_3$  coating (Fig. 7a). When laser repetition rate was increased to 100 kHz, there were only 6 % of squares with ablated transparent coating (Fig. 7b). When laser repetition rate was increased

furthermore up to 200 kHz, the protective coating was not ablated by using the same laser powers and pitch (Fig. 7c). The surface morphology of anodized aluminium samples was examined by using optical microscope. It appeared unchanged in laser processed areas where  $\text{Al}_2\text{O}_3$  coating was not ablated comparing to surface of non-processed areas. The outer surface of the protective anodizing coating was not changed during laser coloring and color modifications were induced at the boundary of coating/substrate interface.

#### 3.2 Luminance $Y'$ versus processing time at different laser powers

Optical microscope images were digitally processed and luminance  $Y'$  was calculated by using Eq. (1) for each processing parameter (Fig. 8).

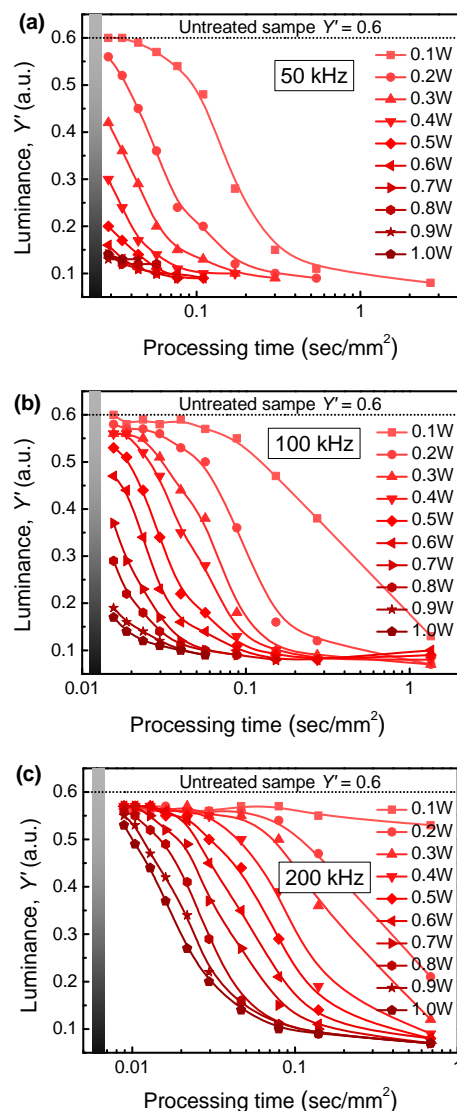

**Fig. 8** Luminance  $Y'$  calculated from optical microscope RGB images of laser processed areas by using Eq. (1) as a function of processing time at different laser powers. The grayscale gradient inserts shows actual colour obtained. Laser repetition rate: (a) - 50 kHz; (b) - 100 kHz; (c) - 200 kHz.

The processed squares with ablated protective  $\text{Al}_2\text{O}_3$  coating (see Fig. 7a,b) were not included in luminance  $Y'$  meas-

urements to Fig. 8. The any grayscale colour starting from 40 % grey (luminance  $Y = 0.6$ , untreated sample) to 93 % grey ( $Y = 0.07$ ) were achieved without damaging the protective  $Al_2O_3$  sample (Fig. 8). The shortest processing time of  $0.04 \text{ sec/mm}^2$  to get 90 % grey ( $Y = 0.1$ ) was achieved by using the 100 kHz repetition rate and the laser power of 1.0W.

#### 4. Conclusions

The laser treatment of aluminium plate with anodizing transparent  $Al_2O_3$  coating by using picosecond laser pulses lead to the grayscale darkening of sample at  $Al_2O_3/Al$  interface. The processing induced grayscale darkening of the sample with the strong dependence of the darkness to the laser power and irradiation time. The grayscale modifications starting from 40 % grey (untreated sample) to 93 % grey were achieved without damaging the protective  $Al_2O_3$  coating. The demonstrated method has promising applications like mobile phone industry.

#### References

- [1] L. Baufay, F. A. Houle and R. J. Wilson: *J. Appl. Phys.*, 61, (1987) 4640.
- [2] J. Qi, K. L. Wang and Y. M. Zhu: *J. Mater. Proc. Technol.*, 139, (2003) 273.
- [3] B. Dusser, Z. Sagan, A. Foucou, M. Jourlin and E. Audouard: *Proc. SPIE*, 7201, (2009) 72010V.
- [4] S. O'Hana, A. J. Pinkerton, K. Shoba, A. W. Gale and L. Li: *Surf. Eng.*, 24, (2008) 147.
- [5] A. Pérez del Pino, P. Serra and J. L. Morenza: *Appl. Surf. Sci.*, 197–198, (2002) 887.
- [6] D. Cormier, J. Taylor and H. West: *J. Manuf. Process.*, 4, (2002) 148.
- [7] M. V. Diamanti, B. Del Curto and M. Pedferri: *Color Res. Appl.*, 33, (2008) 221.
- [8] Z. L. Li, H. Y. Zheng, K. M. Teh, Y. C. Liu, G. C. Lim, H. L. Seng and N. L. Yakovlev: *Appl. Surf. Sci.*, 256, (2009) 1582.
- [9] A. Lehmuskero, V. Kontturi, J. Hiltunen and M. Kuittinen: *Appl. Phys. B*, 98, (2010) 497.
- [10] H. Y. Zheng, G. C. Lim, X. C. Wang, J. L. Tan and J. Hilfiker: *J. Laser Appl.*, 14, (2002) 215.
- [11] A. J. Antończak, D. Kocoń, M. Nowak, P. Koziół and K. M. Abramski: *Appl. Surf. Sci.*, 264, (2013) 229.
- [12] A. Pérez del Pino, J. M. Fernández-Pradas, P. Serra and J. L. Morenza: *Surf. Coat. Technol.*, 187, (2004) 106.
- [13] A. Antończak, B. Stępak, P. Koziół and K. Abramski: *Appl. Phys. A*, (2013) 1.
- [14] B. Dusser, Z. Sagan, H. Soder, N. Faure, J. P. Colombier, M. Jourlin and E. Audouard: *Opt. Express*, 18, (2010) 2913.
- [15] J. Yao, C. Zhang, H. Liu, Q. Dai, L. Wu, S. Lan, A. V. Gopal, V. A. Trofimov and T. M. Lysak: *Appl. Surf. Sci.*, 258, (2012) 7625.
- [16] A. Y. Vorobyev and C. Guo: *Appl. Phys. Lett.*, 92, (2008) 041914.
- [17] H. Lochbihler: *Opt. Express*, 17, (2009) 12189.
- [18] A. Pérez del Pino, P. Serra and J. L. Morenza: *Thin Solid Films*, 415, (2002) 201.
- [19] C. Langlade, A. B. Vannes, J. M. Krafft and J. R. Martin: *Surf. Coat. Technol.*, 100-101, (1998) 383.
- [20] M. Kang, E. Oh, I. Kim, S. W. Kim, J.-W. Ryu and Y.-G. Kim: *Curr. Appl. Phys.*, 12, (2012) 489.
- [21] T. Her, R. J. Finlay, C. Wu, S. Deliwala and E. Mazur: *Appl. Phys. Lett.*, 73, (1998) 1673.
- [22] W. Frank, G. Koch and J. Mills: "Aluminum: Properties and Physical Metallurgy" ed. by J. Hatch, (American Society for Metals, Ohio, 1984) p.1-24.
- [23] R. E. Bolz and G. L. Tuve: " ed. byCRC Press, Boca Raton, 1973) p.1184.
- [24] S. Sigamani, P. Thangavelu, K. N. Srinivasan and M. Selvam: *Int. J. Innov. Res. Sci. Eng. Technol.*, 3, (2014) 13869.
- [25] M. Datcheva, S. Cherneva, M. Stoycheva, R. Iankov and D. Stoychev: *Mater. Sci. Appl.*, 2, (2011) 1452.
- [26] J. M. Liu: *Opt. Lett.*, 7, (1982) 196.
- [27] H.-C. Lee: "Introduction to Color Imaging Science" ed. by M. Storey, (Cambridge University Press, New York, 2005) p.695.

(Received: July 11, 2014, Accepted: November 12, 2014)