

Green micro-resistojet research at Delft University of Technology: new options for Cubesat propulsion

A. Cervone¹ · B. Zandbergen¹ · D. C. Guerrieri¹ · M. De Athayde Costa e Silva¹ · I. Krusharev¹ · H. van Zeijl²

Received: 5 January 2016 / Revised: 7 June 2016 / Accepted: 21 July 2016 / Published online: 30 July 2016
© The Author(s) 2016. This article is published with open access at Springerlink.com

Abstract The aerospace industry is recently expressing a growing interest in green, safe and non-toxic propellants for the propulsion systems of the new generation of space vehicles, which is especially true in the case of Cubesat micro-propulsion systems. Demanding requirements are associated to the future missions and challenges offered by this class of spacecraft, where the availability of a propulsion system might open new possibilities for a wide range of applications including orbital maintenance and transfer, formation flying and attitude control. To accomplish these requirements, Delft University of Technology is currently developing two different concepts of water-propelled micro-thrusters based on MEMS technologies: a free molecular micro-resistojet operating with sublimating solid water (ice) at low plenum gas pressure of less than 600 Pa, and a more conventional micro-resistojet operating with liquid water heated and vaporized by means of a custom designed silicon heating chamber. In this status review paper, the current design and future expected developments of the two micro-propulsion concepts is presented and discussed, together with an initial analysis of the expected

performance and potential operational issues. Results of numerical simulations conducted to optimize the design of the heating and expansion slots, as well as a detailed description of the manufacturing steps for the conventional micro-resistojet concept, are presented. Some intended steps for future research activities, including options for thrust intensity and direction control, are briefly introduced.

Keywords Micro-propulsion · Resistojet · CubeSats · Green propellants

List of symbols

A_S	Cross sectional area of one expansion slot (m^2)
F_T	Thrust (N)
g_0	Earth's gravitational acceleration at sea level (m/s^2)
I_{sp}	Specific impulse (s)
K	Boltzmann constant (J/K)
M	Total satellite mass (kg)
\dot{m}	Mass flow rate (kg/s)
M_p	Propellant mass (kg)
M_w	Molar mass (kg/kmol)
N_A	Avogadro number (–)
N_S	Number of expansion slots (–)
p_0	Plenum pressure (Pa)
T_0	Plenum temperature (K)
T_w	Heater wall temperature (K)
α	Transmission coefficient (–)
ΔV	Delta-V (m/s)

This paper is based on a presentation at the 5th CEAS Air & Space Conference, September 7–11, 2015, Delft, The Netherlands.

✉ A. Cervone
A.Cervone@tudelft.nl

¹ Space Systems Engineering, Aerospace Engineering Faculty, Delft University of Technology, Kluyverweg 1, 2629 HS Delft, The Netherlands

² Else Kooi Laboratory, Electrical Engineering, Mathematics and Computer Science Faculty, Delft University of Technology, Feldmanweg 17, 2628 CT Delft, The Netherlands

1 Introduction

CubeSats are a special type of research spacecraft in the nano-satellite class (launch mass in the range from 1 to 10 kg) which, especially with the recent developments in

miniaturization technologies, are more and more opening the floor for future commercial applications. The standard CubeSat is often called a “1U” CubeSat, has a volume of exactly 1 l (10 cm cube), a mass of no more than 1.33 kg and typically uses commercial off-the-shelf (COTS) components. Simplification of the satellite infrastructure and use of off-the shelf electronic components make it possible to design and produce a working satellite at low cost [1]. Although CubeSats originated in the Academic environment, several research institutions and commercial companies are also involved in CubeSat research around the world [2].

Without a dedicated propulsion system, the CubeSat platform can never totally realize the potential of replacing its larger counterparts, imposing a limit on the exponential growth that CubeSats launches have shown in recent years [3]. Propulsive capabilities would enable the CubeSat platform to engage in a wider range of missions such as those characterized by many satellites flying in formation or in a constellation, possibly even in low altitude orbits [4]. The strict mass, volume, and power limitations typically imposed by CubeSat requirements need unique micro-technologies to help develop a compliant propulsion system. Micro-electromechanical systems (MEMS) at a micro-scale size and high level integration are considered to be the most suitable for this class of satellites [5].

Currently, in the aerospace industry, there is a growing interest in green, non-toxic propellants. This is especially true for Cubesat micro-propulsion systems, given their wide use in Universities as a training means for students, and also because most Cubesats are still launched piggy-back and are required to not endanger the primary payload. Unfortunately, especially when chemical and electro-thermal concepts are considered, a large portion of the good-performance propellants are apt to be a very active chemical and most of them are corrosive, flammable, and/or toxic. One of the most typical “green” propellant choices is the use of an inert gas. However, this leads to large storage tanks or, alternatively, to excessively high tank pressures. Ice or liquid water is another potentially promising green propellant, due to its high mass density. Electro-thermal micro-thrusters using water as propellant can potentially provide a specific impulse comparable to advanced chemical systems and generate enough thrust and Delta-V to accomplish the needs of a typical CubeSat formation flying mission [6, 7].

The Space Engineering Department at Delft University of Technology is well known for its work on the design, development and launch of educational nano-satellites [8]. In the current roadmap of the group, formation flying of two or more satellites represents one of the most important milestones, with an initial demonstration expected during the upcoming DelFFi mission [9]. To accomplish

the requirements associated to this kind of formation flying missions, several types of water-propelled micro-thrusters are currently under development, mostly based on MEMS technologies [10], including a low-power free molecular micro-resistojet (FMMR) and a more conventional micro-resistojet. Both these concepts offer many potential advantages, such as high integration capability, small volume, light mass, fast response, high thrust mass ratio, high reliability, easy integrability in a thruster array. The FMMR, with its low plenum gas pressure of less than 1000 Pa, can provide a thrust level in the order of several μN to a few mN and is suitable for precise attitude control of CubeSats [11]. The water micro-resistojet thermally gasifies liquid water to a high temperature vapour for expulsion via a conventionally shaped nozzle, and has a wide potential for in-orbit maneuvers of CubeSats due to its higher achievable thrust level and specific impulse [12, 13].

Some of the recent activities on micro-propulsion for CubeSats include (but are obviously not limited to) the work of NanoSpace in Sweden [14], TNO in the Netherlands [15] and ClydeSpace in the United Kingdom [16], as well as some projects funded by the European Union such as the ones presented in [17] and [18]. For what concerns micro-propulsion concepts specifically based on water, the Ohio State University has worked on water PPT thrusters [19], capable of offering a much higher specific impulse than Teflon-based ones (up to more than 11,000 s) due to the lower molecular mass of water, but suffering from very low power efficiency which practically confines their use to much larger spacecraft than CubeSats. The University of Central Florida and the company Research Support Instruments have developed a water Microwave Electro-Thermal thruster offering a specific impulse as high as 800 s, but apparently not scalable to power levels lower than 100 W [20]. Finally, a water electrolysis thruster has recently been under development by the company Tethers Unlimited [21]. This concept is based on generating hydrogen and oxygen from water by means of an electrolytic process and producing thrust energy with their combustion. It has been proven to produce a thrust of 200–500 mN at a specific impulse of about 250 s, but requires a very high amount of energy for the hydrolytic process and is, therefore, intrinsically inefficient.

With respect to these other activities, the research work currently ongoing at Delft University of Technology on water propelled MEMS micro-propulsion systems for CubeSats is following a completely different direction, as presented in this paper. In particular, the micro-thrusters design and a preliminary analysis of the FMMR and the water micro-resistojet performance are described and critically compared to other propulsion alternatives. Some of the next steps for future research activities are finally discussed.

2 Requirements

The requirements currently used for the design of the micro-propulsion systems presented in this paper are derived from the formation flying needs of the DelFFi mission [10], but can easily be applied to a wide range of possible future missions involving nano-satellites. A brief summary of the most important among these requirements is provided in the following.

In this particular mission, the total Delta- V provided by the propulsion system shall be at least 15 m/s which, for the given satellite characteristics, translates into a total impulse of at least 54 N s. This amount has been estimated to be sufficient to perform a complete formation flying demonstration (formation acquisition and keeping) for 30 days at an orbital altitude of 350 km. The vacuum thrust generated by the system shall be 0.5 mN as a minimum (based on the assumption that, to ensure sufficient maneuverability of the satellite, the thrust produced should preferably be at least ten times higher than the maximum estimated aerodynamic drag) and 9.5 mN as a maximum (to avoid too large disturbance torques due to thrust misalignment). A response time to satellite commands of no more than 2 s is required, as well as a life time of the system of at least 5000 on-off cycles. The peak power consumption of the system shall not be higher than 10 W, and its total energy consumption shall not be higher than 100 kJ per day. The internal pressure of all propulsion system components shall not be higher than 10 bar; note, however, that this requirement can potentially lead to issues associated to Cubesat regulations, which may require to not include in the satellite any pressurized element prior to launch. This is one of the reasons why an alternative concept without any pressurized items is being studied, as further explained in Sect. 4. Finally, the total wet mass of the system shall not be higher than 450 g and its size shall be within 90 mm \times 90 mm \times 80 mm (approximately equal to one CubeSat unit). The propellant(s) shall not be hazardous for the operators or the other satellite sub-systems. This last requirement, in particular, limits the choice to basically two possible propellants: liquid water and/or gaseous nitrogen, to be used in a resistojet concept to achieve the required performance. The option of using gaseous nitrogen as the only propellant, however, although already considered in a previous study conducted at Delft University of Technology [22], was dropped off because the given requirements in terms of propulsion system mass, volume and allowed pressure would have required an extremely high propellant temperature to achieve the Delta- V requirement of 15 m/s. Therefore, it has been decided to focus the research on propulsion system concepts using water, stored either in the liquid state or in the solid one (ice), which makes it possible to store the required propellant mass in a much smaller tank volume without using extremely high pressures or temperatures.

Water is potentially an excellent space propellant (especially as far as small satellites and Cubesats are concerned), combining relatively low molecular mass with intrinsic safety, non-toxicity and cheapness. It is easily storable and its relatively high density allows for smaller tank volume when compared to other propellants. In a simplified first-order approximation, the specific impulse is inversely proportional to the square root of the propellant molecular mass; however, an excessively low molecular mass would not be acceptable, because it would be associated to very low density and extremely large propellant storage volumes. With a molecular mass of 18 g/mol, water represents a very good compromise between these two contrasting needs. When used in electro-thermal propulsion systems, however, the high specific heat and high latent heat of vaporization of water represent two important limiting factors for the efficiency of the system.

3 Liquid water micro-resistojet

Under the given assumptions, it is easy to calculate the minimum acceptable specific impulse I_{sp} of the system, which is in turn directly related to the temperature at which the propellant needs to be heated, using the linear approximation of the rocket equation:

$$\Delta V = g_0 I_{sp} \cdot \frac{M_p}{M} \quad (1)$$

where g_0 is the gravitational acceleration at sea level. For a satellite mass $M = 3.6$ kg, typical of triple-unit Cubesats, the above relationship gives, for the required ΔV of 15 m/s, a minimum acceptable specific impulse of 110 s.

In the first concept described in this paper, the water used as propellant is pressurized by means of gaseous nitrogen, vaporized in the heating chamber and finally expelled as vapour. Figure 1 shows a schematic of the concept. A usable propellant mass $M_p = 50$ g, compatible to the requirement for the mass of the whole propulsion system, has been considered for the design.

3.1 Thruster design

The general thruster design philosophy was decided after a trade-off between two options: use of a completely COTS-based system and conventional manufacturing techniques, or a MEMS-manufactured thruster in which the valve is the only COTS and not custom-designed component [12]. The second option was eventually selected and further developed, based on the design presented in the following [13]. The manufacturing of the thruster has been possible through a collaboration with TU Delft's Else Kooi Laboratory (formerly DIMES, Delft Institute for Microsystems

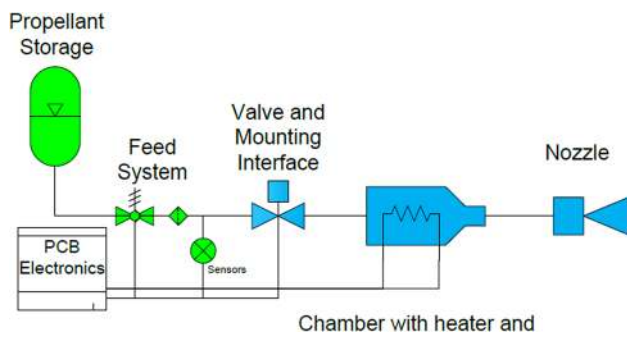

Fig. 1 Schematic of the liquid water micro-resistojet system, with feeding system components in *green* and thruster components in *blue* [12]

and Nanoelectronics). The design methodology, materials and accuracies have, therefore, been chosen based on the capabilities and expertise of our research partner. The general structure of the thruster is based on a modular design, in which the different parts (inlet section, heating chamber and nozzle) can be interchanged to test different combinations of concepts.

An important functional section of the thruster is the heating chamber, where the propellant is vaporized and brought to high temperature. Since the chamber is made of MEMS components, the designer has a significant level of freedom in defining its geometry and internal features, which are mainly bounded by the precision constraints of the manufacturing technique used. Among the many existing options, the following ones have been considered for the design (see Fig. 2):

- No structures, open rectangular cross-section
- Channels or straight fins parallel to the flow direction
- Winding or serpentine channels or fins
- Free standing pillars or fins.

For the first engineering models produced and tested, two heater geometries have been selected: the semi-circular serpentine and the diamond pillars. The selection of these

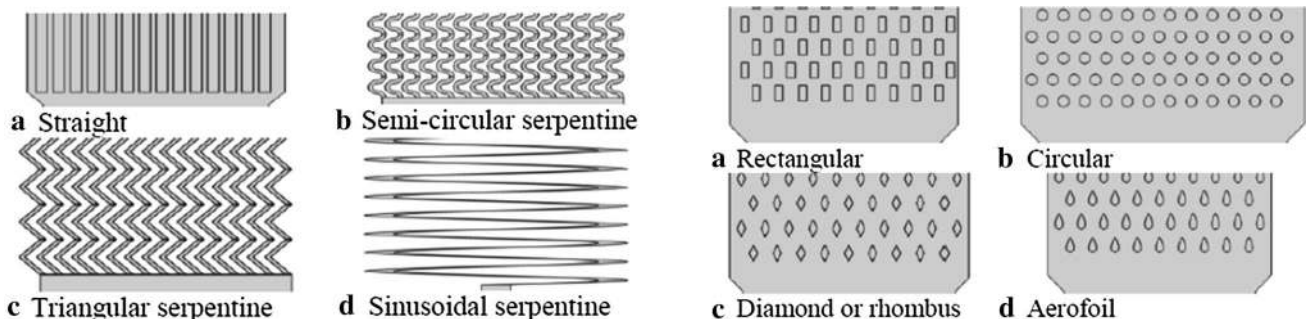

Fig. 2 Schematic representation of some of the options considered for the heating chamber with channels (*left*) and pillars (*right*) [13]

geometries has been based on a combination of different reasons, including simplicity of manufacturing, predicted pressure drop and thermal efficiency, uniformity of the flow field [13]. To minimise the heat losses to the environment, the resistive heating elements are placed in the centre of the heating chamber channel. Half of the thruster flow channel is etched in one silicon wafer and the other half is mirror etched in a different silicon wafer, and these mirrored sections are then bonded one to each other with the heating layer in between, forming a closed flow chamber. The heating elements are suspended in between the pillars or the channels, as shown in the two SEM images in Fig. 3.

Each thruster is nominally made of seven heating sections in series (see Fig. 4), each with a length in the direction of the flow of 1.28 mm and a width of 3 mm. The nominal design power for each section is 1 W, thus leading to a total nominal heating power needed by the thruster of 7 W. Assuming that the satellite bus provides a supply voltage of 5 V, the 1 W of power needed per heater would be achieved with a current of 200 mA. Constant current operation is considered the nominal case for this thruster, because the SiC material chosen for the heating elements (see next sections) has decreasing resistance with temperature and, thus, at higher temperatures the required power decreases when working in constant current mode, and increases when working in constant voltage mode. Calculations based on energy conservation inside the heaters [10] show that, to meet the performance requirements, the maximum acceptable heat leak between the thruster and the surrounding environment shall not exceed 0.013 W/K.

For designing the nozzle and estimating its performance, it shall be taken into account that for nozzles producing thrust in the order of a few mN, not only geometry but also boundary layers and surface roughness play a significant role: in nozzles of this size, as a consequence of flow separation, the effective throat area can be significantly smaller than the nominal one and the difference between ideal and actual performance is normally not negligible. Furthermore, since water is used as propellant,

Fig. 3 SEM pictures of the suspended heating elements for two different geometries [13]

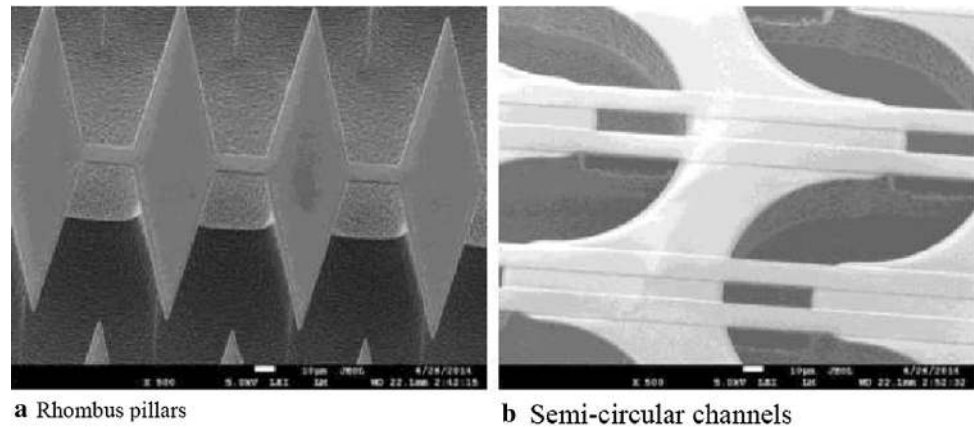

Fig. 4 Schematic of the thruster design with seven heating sections (flow direction from left to right)

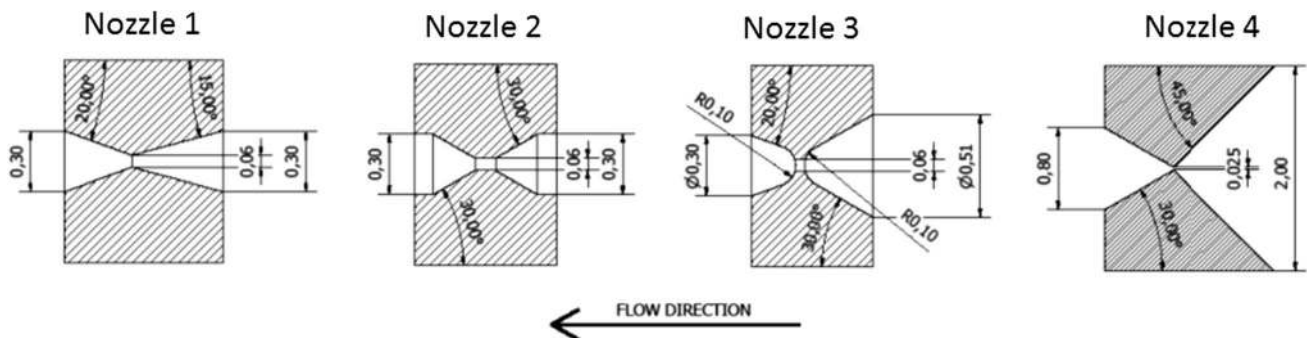
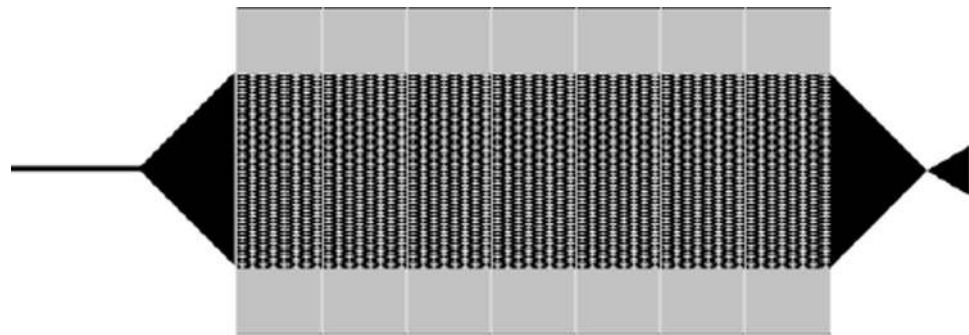

Fig. 5 Nozzle geometries considered in the preliminary analysis (dimensions in mm). Nozzles 1–3 are axisymmetric, while nozzle 4 has rectangular section with 0.1 mm length

condensation in the nozzle exhaust is another aspect to be considered and avoided, and phase change should also be taken into account for more accurate simulation. Therefore, the performance of the thruster cannot be obtained accurately enough with the ideal rocket theory, and CFD simulations need to be used. Several possible geometries have been studied through an analysis performed using ANSYS Fluent® v14.5. For modelling the flow in the nozzle, the SST $k-\omega$ model was used with corrections for Low Reynolds numbers and compressibility effects. Figure 5 shows in detail the considered options. All nozzles are of an

axisymmetric design except for nozzle 4, which is designed as a slit (2-D) nozzle with a length of 100 μm and has a slightly higher expansion ratio than the other ones (32 versus 25).

Table 1 shows the main results of the analysis, for two different chamber pressures. Results from one-dimensional ideal rocket theory have been used to allow determining the discharge coefficient (ratio of actual to ideal mass flow rate) and the specific impulse quality (ratio of actual specific impulse to ideal specific impulse). Results shown in the table indicate that ideally nozzle 1 offers best performance

Table 1 CFD results for various nozzles using water vapour propellant at a chamber temperature of 550 K

	Nozzle 1	Nozzle 2	Nozzle 3	Nozzle 4	Ideal
Chamber pressure = 7 bar					
Mass flow (mg/s)	2.65	2.43	2.18	2.28	2.62
Discharge coefficient (-)	1.010	0.926	0.831	0.869	1
Exhaust velocity (m/s)	1147.7	1107.1	1069.6	970.9	1328.0
Thrust (mN)	3.04	2.69	2.33	2.22	3.48
Specific impulse (s)	117.0	112.9	109.0	99.0	135.4
Specific impulse quality (-) (%)	86.4	83.3	80.5	73.1	100
Chamber pressure = 5 bar					
Mass flow (mg/s)	1.88	1.72	1.55	1.63	1.87
Discharge coefficient (-)	1.003	0.918	0.827	0.870	1
Exhaust velocity (m/s)	1135.8	1092.8	1065.3	930.4	1328.0
Thrust (mN)	2.13	1.88	1.65	1.52	2.49
Specific impulse (s)	115.8	111.4	108.6	94.9	135.4
Specific impulse quality (-) (%)	85.5	82.3	80.2	70.0	100

All results are referred to expansion to vacuum conditions

Table 2 Estimated performance of the micro-resistojet with nozzle 4, at two different values of the propellant temperature in the heating chamber, for a chamber pressure of 5 bar and a total propellant consumption of 50 g

Parameter	Case 1	Case 2	Unit
Chamber temperature	550	773	K
Thrust	1.52	1.48	mN
Mass flow rate	1.63	1.36	mg/s
Power transferred to water	5.25	5.06	W
Specific impulse	94.9	111	s
Total impulse	46.4	54.7	N s

in terms of specific impulse quality. Nozzles 2 and 3 have a slightly lower performance, as well as nozzle 4 in spite of its higher expansion ratio.

3.2 Preliminary performance analysis

Although it offers a slightly lower specific impulse quality, nozzle 4 is currently selected for the thruster due to its much better manufacturability in the MEMS modular design. Table 2 provides the estimated thruster performance for two different values of the chamber temperature, 550 K (same as Table 1) and 773 K. The table assumes a chamber pressure of 5 bar and a total propellant consumption of 50 g. The chamber pressure and temperature, in this case, are referred to the vapour flow at the nozzle entrance (thus, after passing through the heating chamber).

At 550 K, the specific impulse is still too low and the total impulse is not sufficient to meet the Delta-V requirement of 15 m/s: if this temperature is chosen as the nominal operational one, a quantity of propellant slightly higher

than 50 g will be needed to achieve the required performance. For a chamber temperature of 773 K all requirements, in particular those on thrust and Delta-V, are met.

The table shows that, in both cases considered, the power that needs to be transferred to the propellant is higher than 5 W (out of the 7 W available from the electrical resistance), meaning that the heating efficiency of the system needs to be higher than 70 %. It is worth noticing that this transferred power tends to increase with the chamber pressure, as a consequence of the direct dependence of the mass flow rate on the pressure: at higher mass flow rate, a larger amount of power is needed to provide the same temperature increase to the fluid. As a matter of fact, with the current geometry and specifications of the thruster, a chamber pressure higher than 6 bar would not be enough to completely vaporize the water.

It can also be observed that more than 60 % of the power transferred to the propellant is used for the phase change from liquid to vapour, due to the very high value of the latent heat of evaporation for water. Finally, an apparently surprising result shown by Table 2 is the lower amount of power needed to achieve the higher chamber temperature of 773 K (when compared to 550 K), as a consequence of the decreasing mass flow rate with temperature when the chamber pressure stays constant.

One of the most important design parameters is the heating chamber length, especially when taking into account the very low flow velocity, and thus the highly laminar flow in it. Although the design length has been chosen based on preliminary estimations showing that complete vaporization of the fluid is possible within the chamber, this might not happen in the real tests, especially if the heating efficiency proves to be too low. This is one of the reasons why a modular design has been chosen, giving the possibility

of adding more elements and making the heating chamber longer if needed.

3.3 Manufacturing and current status

In this thruster concept, the resistive heater elements are made of silicon carbide (SiC), based on the technology recently developed at the Else Kooi Laboratory [23]. SiC is a very promising material due to its inertness, high strength, relatively low density and high maximum operating temperature. The propellant flow channels are etched out in silicon, the easiest and cheapest production method for these kinds of structures; the inaccuracy of the etching process, in this case, is below 10 % of the channel depth. The thrusters are designed to be enclosed on both sides by an anodically bonded layer of glass for conductive insulation. A reflecting metal layer is applied to the outside of this glass layer to work as a radiation shield. The last layer, with a width of approximately 1 cm, is made of encasing resin compound, to provide additional rigidity, insulation and protection.

The manufacturing process starts with an empty silicon wafer, on top of which an isolating silicon dioxide layer and the silicon carbide heating layer are deposited. The dioxide layer is used to electrically isolate the heating layer from the conductive silicon wafer. On top of the heaters another silicon dioxide layer is deposited, to electrically isolate the heaters from the silicon wafer which will be subsequently placed. The heating structure is etched in this first set of layers, then the channels are etched in two steps: first using an anisotropic etching procedure (deep reactive-ion etching, DRIE), then by isotropic etching, i.e. in all directions (still by DRIE, but without any passivation), to etch away the structure underneath the heating elements and make them suspended. This structure is, however, only the bottom half of the thruster; the other half is obtained in a similar way, with the only difference that there is a pocket in the location where the heating elements are on its counterpart. Finally, the two halves are bonded together with a silicon fusion bonding process, to form the closed thruster structure without posing additional limitations on the maximum acceptable operational temperature of the system. To connect the heating elements to the power supply, 1×1 mm square holes are etched on top of the silicon wafer and extend from it to the SiC heating layer in the centre. Since the electrical bond wires cannot be bonded on SiC directly, a thin aluminium layer is first deposited on top of the exposed SiC, and wires are later bonded to this aluminium.

A wafer produced with this technique is shown on the left hand side of Fig. 6. The figure shows the wafer before the final step when the two halves of the flow channel are bonded together, thus the heating element structure and the flow channel are still well visible. It can be observed that

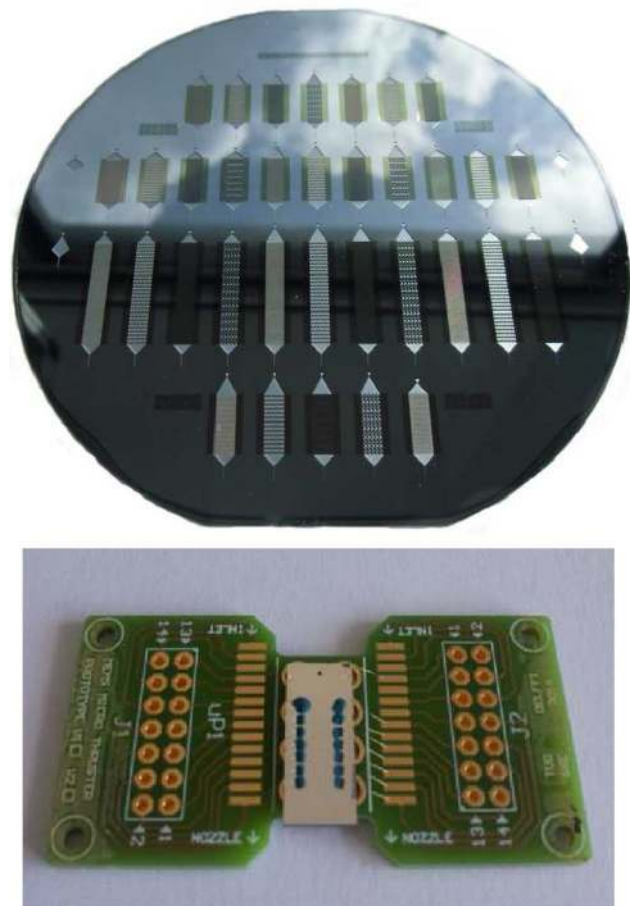

Fig. 6 Top silicon wafer with several different thruster configurations, showing half of the flow channel including the SiC heating elements [13]. Bottom picture of a complete thruster prototype, including PCB

several options for the channel geometry were realized, thus allowing testing of a large number of different thruster configurations.

The last step of the manufacturing process is represented by bonding the thruster to a custom-made Printed Circuit Board (PCB) for testing and operation. Once bonded, micro golden bond wires are connected from the thruster bond pads to the generic electrical connections on the PCB. After wire-bonding, the bond cavities are hermetically sealed with a low-viscosity sealant. The right side of Fig. 6 shows one of the final thruster prototypes, ready for the testing phase.

At the current development stage, several thruster prototypes have been completely manufactured and successfully checked for electrical integrity. These thrusters will be tested for their propulsion performance in different steps, starting from simple functionality tests with gaseous nitrogen as propellant, and then proceeding to fully representative tests using water.

Fig. 7 Preliminary architecture of the FMMR propulsion system [11]

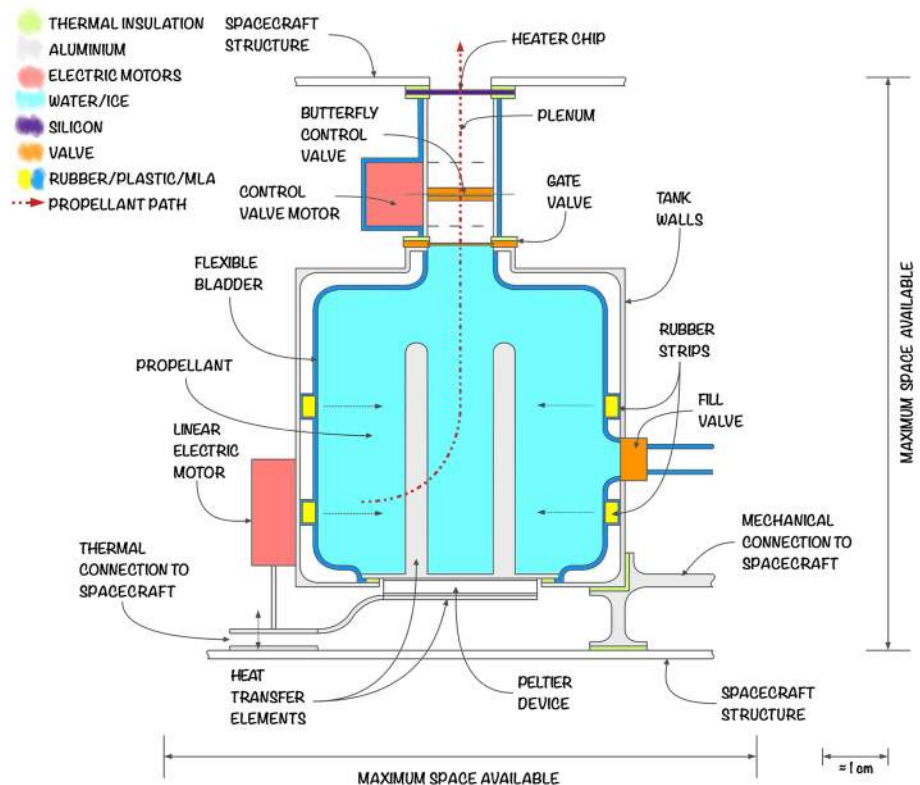

4 Free molecular micro-resistojet

One of the main limitations of the liquid water micro-resistojet concept presented in the previous section comes from the need to slightly pressurize the propellant to meet the requirements which, as previously explained, might lead to compliance issues with Cubesat regulations. In addition, the use of a liquid propellant pressurized by a gas is intrinsically associated to problems related to complex mixing phenomena of the two phases in a low gravity environment. For these reasons, TU Delft has started to work at an alternative concept: a low-pressure free molecular resistojet using water stored in its solid state and operating under sublimating conditions [11]. This innovative design concept represents an extension of a similar design developed and tested by Ketsdever et al. in the period between 2000 and 2005 [24–26], but propellants stored in the solid phase were never implemented in that particular concept.

4.1 Theoretical background and preliminary system architecture

In the proposed propulsion system concept, some ice molecules sublime to maintain the pressure inside the tank equal to the vapour pressure (approximately 600 Pa at 0 °C). The sublimation absorbs some heat from the ice and lowers its temperature, with the amount of absorbed heat

determined by the enthalpy of sublimation of water. A heating element pumps the same amount of heat into the ice, to maintain the temperature and vapour pressure in the tank constant. Some ice vapour molecules will move from the tank through the feed system into a plenum; this in turn lowers the pressure in the tank below the vapour pressure, so more ice sublimates and the cycle is maintained. The molecules in the plenum then flow through one or more heating sections with high temperature walls, which in this concept are at the same time the heating elements and the expansion slots. The molecules are heated by collisions with the walls, and part of them is expelled to outer space and generates thrust. The working principle is, therefore, the same as a micro-resistojet, since electric power is used to energize the propellant before it is expelled.

In Fig. 7 a possible preliminary architecture of the system is shown. The heater chip and the plenum represent only a small part of the system; the other important component is the propellant storage system (bottom part of the drawing, from the gate valve down), including in particular the main tank.

The heater chip, thermally insulated from the rest of the system and coated to reduce radiative losses, is expected to be made of silicon, with approximately 10 mm sides and 0.5 mm thickness, including the necessary number of expansion slots to meet the requirements given in Sect. 2. The best candidate material for the coating is gold, with

Fig. 8 Schematic representation of molecules entering and exiting an expansion slot [11]

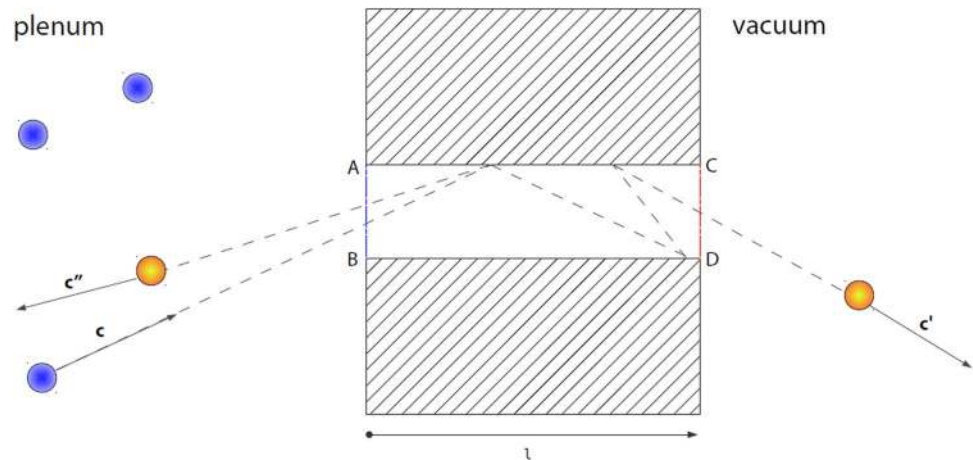

platinum and rhodium as possible alternatives in case higher temperatures need to be achieved. The plenum is the “feeding system” of this concept; it has the same cross-section of the heater element and a wall thickness defined in such a way to withstand all launch loads. An electrically actuated butterfly valve is used to control the propellant flow from the main tank to the plenum, by adjusting the mass flow rate at the desired value. Another on–off gate valve is, however, expected to be needed: this valve will remain closed during the launch and initial orbital phases, to keep all the propellant inside the main tank, and opened at the moment when the thruster starts its operations in space. The main tank has not only to ensure enough structural resistance, but also to avoid that vapour pockets form in areas from where the gas molecules cannot reach the plenum. To achieve this result, a possible option is to combine a rigid outer aluminium layer with a flexible inner membrane. Finally, the heating and cooling system consists of a Peltier device, aluminium heating fins and a thermal connection to the spacecraft.

In the least possible complex concept, the expansion slot has a very simple rectangular geometry, since the very low operational pressure (less than 600 Pa) of this system makes the typical convergent–divergent nozzle shape not practical. As indicated before, the expansion slot is also the heating element in this case, with the heat being exchanged through its internal walls. Due to the low plenum pressure, the physics of this kind of thruster cannot be described by means of the usual continuum flow assumptions, and analytical models or numerical solvers based on the Navier–Stokes equations would not give accurate results. Since typical Knudsen numbers are in the order of 0.1–1, particle-based models and rarefied gas dynamics have to be used. As a first approximation, the thruster performance in terms of mass flow rate \dot{m} exhausted from the expansion slot, vacuum specific impulse I_{sp} and vacuum thrust F_T is typically estimated in literature by the following formulae

[24], in which a collision-less flow at high Mach number is assumed:

$$\dot{m} = \alpha p_0 \sqrt{\frac{M_W}{2\pi k T_0 N_A}} A_s N_s \quad (2)$$

$$I_{sp} = \sqrt{\frac{\pi k T_w N_A}{2 M_W g_0^2}} \quad (3)$$

$$F_T = \dot{m} g_0 I_{sp} = \frac{\alpha p_0 A_s N_s}{2} \sqrt{\frac{T_w}{T_0}} \quad (4)$$

In the above equations, p_0 and T_0 are the fluid pressure and temperature in the plenum, T_w is the temperature of the (heated) expansion slot walls, M_W is the molar mass of the propellant, k is the Boltzmann constant, N_A is the Avogadro number, g_0 is the standard gravitational acceleration on Earth’s surface at sea level, N_s is the number of expansion slots, A_s is the cross-sectional area of one expansion slot. The parameter α is denoted as “transmission coefficient”, defined as the ratio of molecules exiting into space from the expansion slot to those entering it, and gives a direct measure of how the geometry of the expansion slot influences the thruster performance. The plenum (see Fig. 8) is filled with the molecules of a rarefied gas, each having some position and some velocity (mainly thermal velocity, since the stream velocity under the given conditions is very small), with a certain number of intermolecular collisions. Some molecules will be carried by their velocity into the expansion slots, where they will interact with the wall and their temperature will ideally rise from T_0 to T_w . Under the assumption that the surface interaction obeys the diffuse model, the velocity of the reflected molecules will have a random direction: some molecules, after a number of collisions with the expansion slot walls, will exit into space,

some others will return to the plenum. The ratio between these two categories of molecules is directly related to the transmission coefficient α .

Equations (2), (3) and (4), however, provide only a very approximate description of the thruster performance and are based on a significant number of simplifying assumptions, some of which are very far from the actual physics of the occurring phenomena. The transmission coefficient α is typically not a constant and depends on several other operational parameters of the thruster, including the plenum pressure and temperature and the expansion slot geometry. In addition, the collision-less flow assumption cannot be considered accurate. Furthermore, the final temperature reached by the molecules is likely to be slightly less than the wall temperature T_w , in analogy to what happens in convective heat transfer. A more accurate model of the thruster is thus needed and is presently under development at TU Delft, some preliminary results of which have been presented in [27]. One remarkable result of this modelling effort shows that the pressure term in the thrust and specific impulse equations is of the same order of magnitude as the momentum term, and can, therefore, not be neglected as it is done in Eqs. (3) and (4) above.

4.2 Expansion slot optimization

A preliminary set of numerical simulations, performed by means of the *dsmcFoam* Direct Simulation Monte Carlo solver of the OpenFOAM CFD package (validated by simulating and comparing the results obtained on the few similar cases available in open literature), allowed to understand the flow behavior inside an expansion slot and to make a first step in the optimization of the slot geometry [11]. In these simulations, to make comparison to existing literature results easier, gaseous nitrogen was used as propellant. The effects of slot length, depth and aspect ratio (i.e., ratio of the length to the depth) were first assessed, showing that for a given thrust and specific impulse larger values of the expansion slot length lead to a lower input power usage and a higher thrust to power ratio, and leading to an “optimum” value of the aspect ratio equal to 2.5. Additional simulations showed that no significant performance improvement is obtained with a convergent slot section; conversely, the presence of a divergent section at the slot exit significantly helps to improve performance, with an estimated thrust level, at an angle of the divergent section equal to 15° , around 30 % higher with respect to the case with no divergent section. In summary the simulations showed that, for the optimum slot geometry, a specific impulse as high as 92 s is possible with a wall temperature of 600°C , which increases up to 110 s for 900°C . Validating these results against the experimental data available in literature proved to be difficult, mainly due to the uncertainty in the exhaust boundary conditions

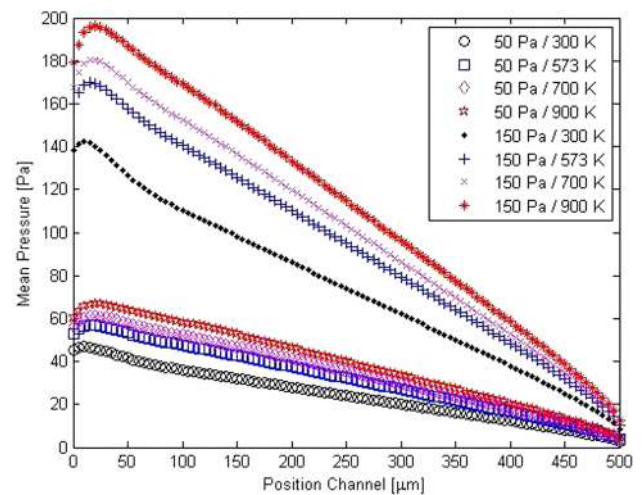

Fig. 9 Average gas pressure along a circular shape expansion channel, for two different plenum pressures and four wall temperatures (plenum temperature = 300 K)

used in the reference cases. The results, however, matched the reference data relatively well, showing a maximum difference of $\pm 10\%$ in the quantitative values and a very good qualitative matching. Two important lessons were learned from this set of preliminary simulations: first, the best possible expansion channel geometry is not necessarily the simple rectangular one proposed by the earlier studies presented in [24–26]; furthermore, this micro-propulsion concept seems to have a great potential and to be capable of providing a comparable performance to more conventional ones, in spite of its extremely low operational pressure. With these lessons in mind, a new and more structured research campaign was started, some initial results of which are presented in the following.

For simplicity, due to the axisymmetric nature of the problem, the simulations were initially performed on an expansion channel with a circular cross-sectional area of $10^4 \mu\text{m}^2$ and a length of $500 \mu\text{m}$. Figures 9, 10 and 11 show, respectively, the average pressure, temperature and axial velocity along the channel, for two different plenum pressures (50 and 150 Pa), a plenum temperature of 300 K and four different heater wall temperatures (300, 573, 700 and 900 K). An evident analogy with the continuum flow in a convergent-divergent nozzle can be noticed: a sort of “expansion” is observed in the channel, with a pressure decrease and an axial velocity increase. The average flow temperature tends to reach its steady state value, equal or slightly lower than the wall temperature, already after the first 20 % of the channel length, and tends to stay constant until the very last part of the channel, where it starts to decrease rapidly.

Figure 9 also shows that, when the wall temperature is the same as the plenum temperature, the average pressure

Fig. 10 Average gas temperature along a circular shape expansion channel, for two different plenum pressures and four wall temperatures (plenum temperature = 300 K)

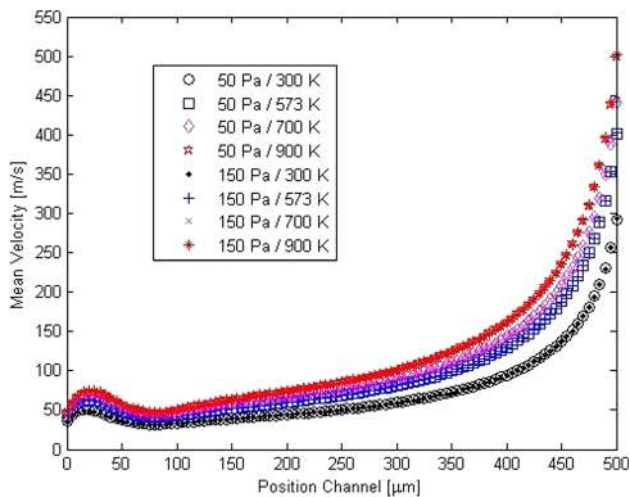
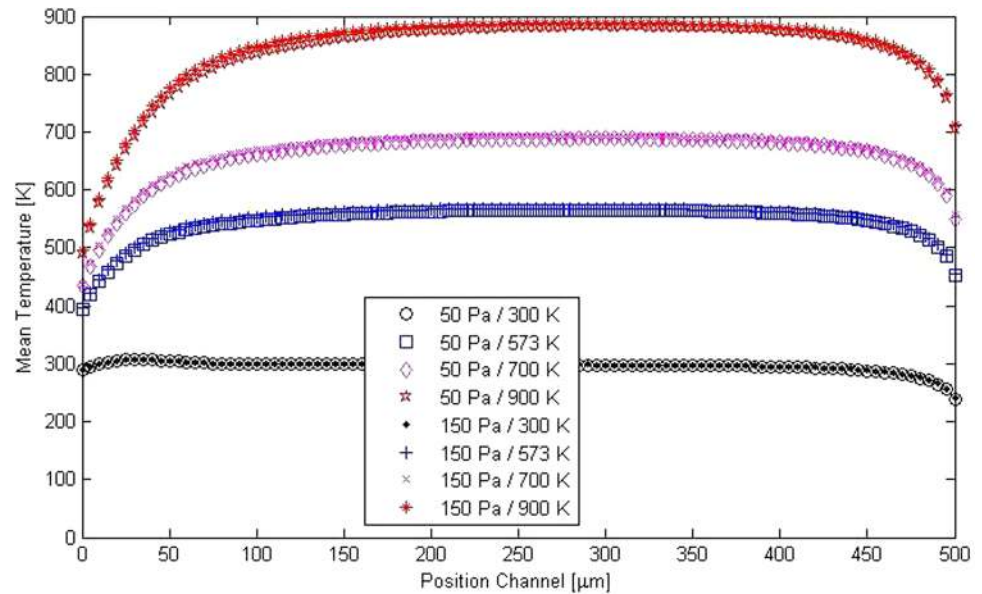

Fig. 11 Average axial flow velocity along a circular shape expansion channel, for two different plenum pressures and four wall temperatures (plenum temperature = 300 K)

at the expansion channel inlet is less than the plenum pressure. On the other hand, when the wall temperature is higher than the plenum temperature, the average inlet pressure is higher as well. This happens because, after colliding with the walls, the molecules increase their temperature (energy) and some of them come back to the plenum. This creates a “thermal barrier” in the channel entrance where the gas becomes more rarefied and makes it more difficult for new molecules to progress towards the channel, as shown in Fig. 12. The figures zoom, in particular, on the channel entrance area, showing the connection between the plenum (left) and the first part of the channel (right).

Another set of simulations were performed on a divergent circular channel with the same inlet area as in the previous ones, and an angle of the divergent section in the range from 0° to 45° . The results seem to show an optimum at an angle between 25° and 30° , as illustrated by Fig. 13 related to the average axial velocity at the channel exit.

The simulation campaign is planned to continue with an extensive set of additional investigations, including: comparison of the results obtained on circular shapes to those related to rectangular slots; characterization of the transmission coefficient as a function of the different flow parameters; definition of an optimized geometry for the successive test phase. The results of these investigations will be presented in following papers.

4.3 Performance analysis

The results shown in the previous section allow to estimate the expected performance of a thruster using, as expansion slot, an array of identical circular channels with $10^4 \mu\text{m}^2$ cross-sectional area and $500 \mu\text{m}$ length. To achieve a thrust level in line with the given requirements with a still feasible manufacturing, an array of 67×67 channels within a $10 \text{ mm} \times 10 \text{ mm}$ chip has been considered. Table 3 shows the results for all plenum pressure and wall temperature values considered in the previous section. The mass flow rate, in this case, is referred to the actual amount of molecules expelled at the expansion slot exit, while the power transferred to water includes both the amounts required to heat the channel walls and to maintain the propellant at the right sublimation conditions in the tank.

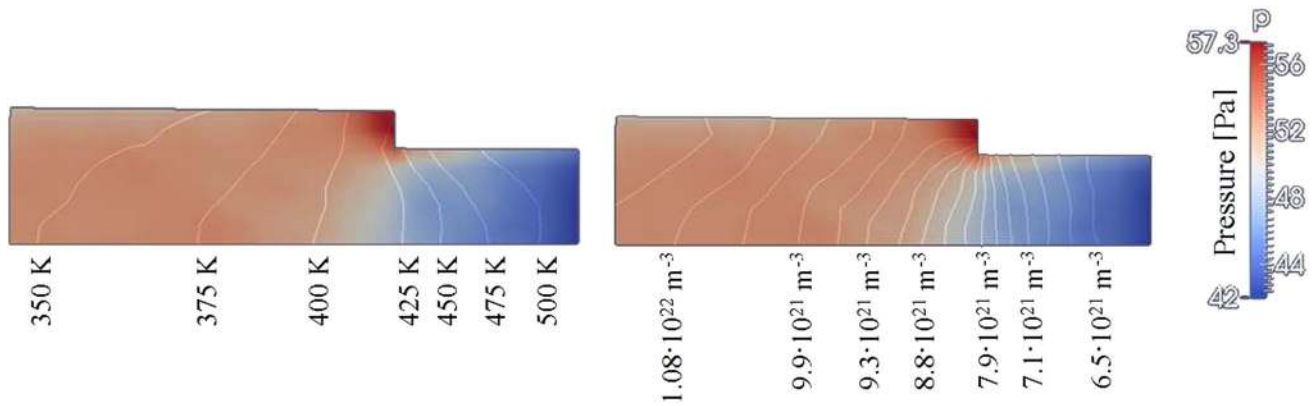

Fig. 12 Pressure distribution, isothermal lines (*left*) and constant number density lines (*right*) at the channel inlet, for a plenum pressure of 50 Pa and a wall temperature of 573 K

Fig. 13 Average axial velocity at channel exit for a divergent circular channel, as a function of the angle of the divergent section, for plenum temperature of 300 K and wall temperature of 573 K

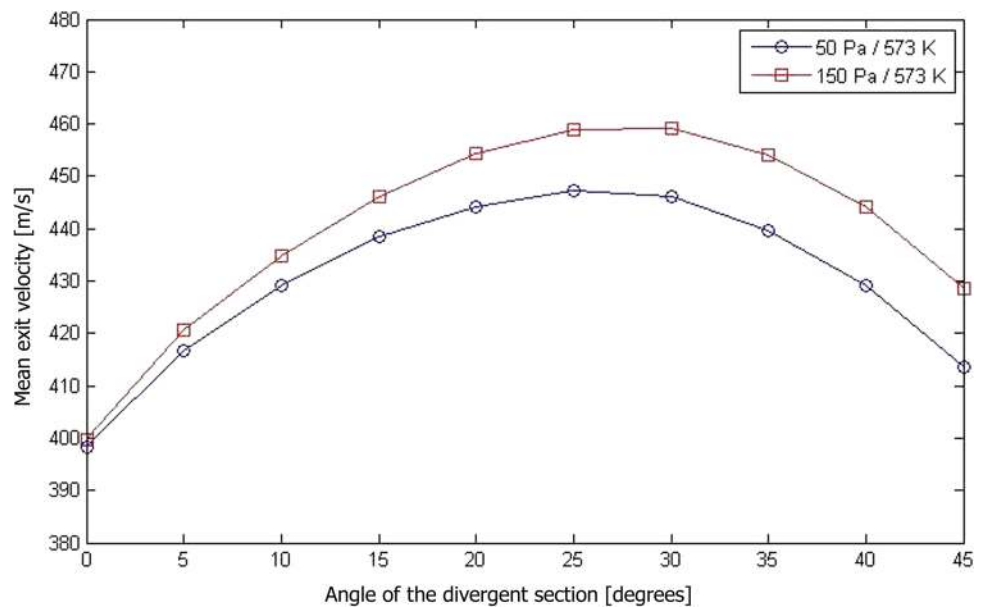

Table 3 Estimated performance of a free molecular micro-resistojet with 67×67 circular expansion channels of $10^4 \mu\text{m}^2$ cross-sectional area and $500 \mu\text{m}$ length, for different values of plenum pressure and channel wall temperature, and total propellant consumption of 50 g

Parameter	Case 1				Case 2				Unit
	50	573	700	900	300	573	700	900	
Plenum pressure	50				150				Pa
Wall temperature	300	573	700	900	300	573	700	900	K
Thrust	0.28	0.39	0.42	0.48	0.86	1.14	1.24	1.4	mN
Mass flow rate	0.45	0.45	0.45	0.45	1.37	1.32	1.31	1.3	mg/s
Power transferred to water	1.46	1.54	1.6	1.71	4.38	4.51	4.65	4.95	W
Specific impulse	63.7	87.3	96.3	108.9	64.1	88.1	97.1	109.9	s
Total impulse	31.2	42.8	47.2	53.4	31.4	43.2	47.6	53.9	N s

It is interesting to observe that, while some of the results are well in line with the classical behaviour expected from the ideal rocket theory, such as for instance the very weak dependency of the specific impulse on the plenum pressure, some other aspects show a completely different behaviour

with respect to classical thrusters based on thermodynamic acceleration of a continuum flow. One example is the thrust level which, in this concept, is clearly dependent on temperature, which in turn is a consequence of an almost constant mass flow rate at variable temperature.

Although the performance values shown in the table seem to meet the given total impulse requirement only at the highest considered value of the wall temperature (900 K), it is worth noticing that, as a consequence of the low operational pressure, this concept allows for a lower propulsion system dry mass than the previously presented liquid vaporizing micro-resistojet. This, in turn, allows for using a larger amount of propellant within the same system wet mass, as further explained in the next section.

5 Critical comparison with other micro-propulsion options

An important aspect to be taken into account, when discussing and comparing micro-propulsion concepts, are the restrictions imposed by CubeSat specifications. These specifications are still written thinking at “piggy-back” launches where the CubeSat is secondary payload of a rocket in which a larger satellite is the primary payload, even if this is not anymore the only launch option for CubeSats. As a consequence, to safeguard the main payload of the rocket, a number of restrictions are imposed: no pressurized items above 1.2 bar, no explosive materials, and a maximum of 100 Wh of stored chemical energy. Although a waiver to these requirements may be requested under particular circumstances, a propulsion system meeting all of them would definitely be preferable.

When choosing the right propulsion system for a small satellite, the main performance parameters to be considered (based on the requirements imposed by the particular application) are the thrust level, the specific impulse and the minimum impulse bit. In some cases, in particular when a comparison between electrical, chemical and electro-thermal propulsion is performed, the system specific impulse also plays an important role due to the different limiting factors driving different types of propulsion systems (power-limited in the case of electric propulsion, energy limited in the case of chemical propulsion).

The minimum impulse bit, in particular, is very important for attitude and orbital control applications. It has to be small enough to ensure precise pointing accuracy of the satellite, which can only be obtained with a tiny thrust level and very short pulses. On the other hand, however, a high thrust level is required to give the spacecraft sufficient agility (or, in other terms, to make sure it rotates sufficiently fast from an initial orientation to a new one), but also for reducing the ΔV required for orbital maintenance and transfer maneuvers. Typical values for a CubeSat are a thrust level of 0.5 mN or higher to provide the spacecraft a rotation of 180° in 1 min, and a minimum impulse bit in the order of 0.1 mN s to avoid deviations in the spacecraft orientation of more than 1° during a time period of 20 s [28].

In addition, a restriction needs to be imposed on the maximum thrust level. The current CubeSat technology does not normally allow for precisely aligning the thrust vector with the center of mass of the satellite, and a misalignment of at least 5 mm between them is very difficult to be avoided. As a result, when activated, the thruster will also produce a small torque that has to be counter-acted by the attitude control system of the satellite to avoid undesired rotations. Considering the maximum disturbance torque level for which the presently available CubeSat attitude control devices are typically designed, which is in the order of 5×10^{-5} Nm, the thrust level should preferably be no more than 10 mN.

These numbers clearly show in which applications the micro-resistojets concepts presented in this paper have the potential to open new opportunities. In the thrust range from no less than 0.5 mN (for agility and efficient orbital maneuvers) to no more than 10 mN (for accuracy), there are few if even no alternatives. Cold gas thrusters could be one of these alternatives, but are typically characterized by thrust and/or specific impulse levels which confine their application to short-lifetime missions or simple attitude control tasks requiring a limited amount of total impulse, unless pressure levels or propellants not compatible with the current Cubesat specifications are used [14].

Considering the minimum impulse bit requirements, however, the given thrust level requires the system to be operated for a very short duration and thus to be designed for an extremely fast response time, in the order of a few tenths or even hundredths of a second. This is not a trivial requirement, especially when heat transfer processes are involved, and represents one of the main challenges to be faced in the next development steps of the system.

In summary, Table 4 compares the estimated performance of the two concepts presented in the paper, under similar temperature conditions and with the same amount of propellant (50 g), when used in the CubeSat mission considered in this study. Under the given conditions, the free molecular resistojet produces a slightly lower thrust and specific impulse than the liquid water one, but also requires less power to be transferred to the propellant; in addition, its lower operational pressure allows for a slightly lower wet mass with the same initial propellant mass. Generally speaking, however, the two systems offer a very similar performance, and an eventual trade-off between them should probably be based more on operational considerations (in particular, the allowed propellant storage conditions in terms of temperature and pressure) than on performance ones.

5.1 Next steps and future plans: micro-thrust control

One of the potential features capable of making a big difference in the use of micro-propulsion systems in small

Table 4 Performance comparison between the two micro-propulsion concepts proposed in this paper, under comparable operational conditions with the same amount of propellant

Parameter	Liquid water resistojet	Free molecular resistojet	Unit
Chamber/channel temperature	550	573	K
Chamber/plenum pressure	5×10^5	150	Pa
Mass flow rate	1.63	1.32	mg/s
Power transferred to water	5.25	4.51	W
Thrust	1.52	1.14	mN
Specific impulse	94.9	88.1	s
Total impulse	46.4	43.2	N s
Propellant mass	50	50	g
Estimated system wet mass	<360	<330	g

scale satellites would be the possibility to control the thrust provided by such systems, in both amplitude and direction. A dedicated research has recently started at TU Delft to this respect, and is expected to become one of the main branches of the micro-propulsion activities of the group in the upcoming future. Micro-propulsion is a relatively young research field, for which thrust control opportunities have not been explored yet to a sufficient extent. Some techniques have been proposed for controlling the thrust vector of an ion thruster, including application of an electrostatic field to change the direction of the ions in the thruster exit [29]. However, the sputtering process in the plates causes excessive damage (although, in case of low deflection, it is still possible to manage and control the grid erosion) and the formation of plasma sheaths can significantly decrease the vectoring ability by changing the surrounding electrical field. Other techniques, proposed in earlier literature for larger-scale systems, include the use of an electrostatic field applied in the holes of the grids, as well as methods to generate a mechanic translation of the grids [30].

The main technique proposed so far to control the mass flow rate (and thus the thrust magnitude) in chemical and electromechanical micro-propulsion systems is the use of micro-pumps, several types of which have been studied based on different technologies [31]: these include displacement pumps (diaphragm or rotary) and dynamic ones (electro-osmotic, electro-kinetic). The research conducted at TU Delft is intended to also look at MEMS and/or 3D printed components, taking advantage of the increasing experience gained by various departments and faculties of the university in these fields and carefully looking at the available pioneering work of other companies and institutions on MEMS valves and micro-thrust controllers [32].

6 Conclusions

Two different green micro-resistojet propulsion concepts specifically designed for use on Cubesats, currently under development at Delft University of Technology, have been

presented in this paper. Both concepts use water as propellant, in the first case stored as a liquid, in the second case as a solid (ice) at very low pressure conditions below the triple point. These concepts meet the typical requirements of possible future Cubesat missions at TU Delft, and are therefore extremely promising to increase the capabilities and range of applications of this class of spacecraft. Future activities will be devoted to further development, validation and performance optimization of the concepts, as well as including additional features such as the possibility of controlling their thrust (in both amplitude and direction) by means of specifically designed MEMS devices. A first fundamental step to this respect will be represented by a thorough experimental validation of the theoretical performance results illustrated in this paper that will be conducted in the test facilities available at Delft University of Technology.

Acknowledgments The authors would like to express their sincere gratitude to the other Academic staff members of the Space Systems Engineering chair of the Aerospace Engineering Faculty at TU Delft, for their constant and continuous support. A special acknowledgment goes to the work of all the students involved, in the framework of their MSc studies and thesis, in the micro-propulsion activities illustrated in this paper. The authors would finally like to acknowledge the support given by the CNPq (Conselho Nacional de Desenvolvimento Científico e Tecnológico—Brasil), which is funding the PhD research of the D.C. Guerrieri and M. De Athayde Costa e Silva.

Open Access This article is distributed under the terms of the Creative Commons Attribution 4.0 International License (<http://creativecommons.org/licenses/by/4.0/>), which permits unrestricted use, distribution, and reproduction in any medium, provided you give appropriate credit to the original author(s) and the source, provide a link to the Creative Commons license, and indicate if changes were made.

References

1. Selva, D., Krejci, D.: A survey and assessment of the capabilities of Cubesats for Earth observation. *Acta Astronaut.* 51–67 (2011)
2. Mannucci, A.J., Dickson, J., Duncan, C.: GNSS Geospace Constellation (GGC): A Cubesat Space Weather Mission Concept.

- Jet Propulsion Laboratory, California Institute of Technology, Pasadena (2010)
3. Zandbergen, B.: Micropropulsion systems for Cubesats. In: Rambaud, P. (ed.) *CubeSat Technology and Applications*, pp. 1–36. Von Karman Institute for fluid Dynamics, Brussels (2013)
 4. Cervone, A., Zandbergen, B., Guo, J., Gill, E.: Application of an advanced micro-propulsion system to the Delfi Formation Flying Demonstration. In: *IAF 63rd International Astronautical Congress*, Naples (2012)
 5. Gronland, T.A., Johansson, H., Jonsson, K., Bejhed, J., Rangsten, P.: MEMS makes a difference in satellite propulsion. In: *4S Symposium “Small Satellites Systems and Services”*, Portoroz (2012)
 6. Scharleman, C., Tajmar, M., Vasiljevich, I., Buldrini, N., Krejci, D., Seifert, B.: *Propulsion for Nanosatellites* (2011)
 7. Mueller, J., Hofer, R., Ziemer, J.: *Survey of propulsion technologies applicable to Cubesats*. Jet Propulsion Laboratory, National Aeronautics and Space Administration, Pasadena (2010)
 8. Bouwmeester, J., Rotthier, L., Schuurbijs, C., Wieling, W., Horn, G.v.d., Stelwagen, F., Timmer, E., Tijssen, M.: Preliminary results of the Delfi-N3Xt mission. In: *4S Symposium “Small Satellites Systems and Services”*, Majorca (2014)
 9. Guo, J., Bouwmeester, J., Gill, E.: From single to formation flying CubeSats: an update of the DelFFi programme. In: *27th Annual AIAA/USU Conference on Small Satellites*. UT, Logan (2013)
 10. Cervone, A., Deeb, A., van Wees, T., Jansen, E., Sundaramoorthy, P., Chu, J., Zandbergen, B.: A micro-propulsion subsystem to enable formation flying on the DelFFi mission. In: *8th International Workshop on Satellite Constellations and Formation Flying*, Delft (2015)
 11. Cervone, A., Mancas, A., Zandbergen, B.: Conceptual design of a low-pressure micro-resistojet based on a sublimating solid propellant. *Acta Astronaut* **108**, 30–39 (2015)
 12. Krusharev, I., Poyck, R., Bellini, Q., Zandbergen, B., Cervone, A.: Cubesat micro-propulsion systems for extending the capabilities of academic projects. In: *IAF 65th International Astronautical Congress*, Canada (2014)
 13. Poyck, R., Cervone, A., Zandbergen, B., van Zeijl, H.W., Krusharev, I., Bellini, Q.: A water-fed micro-resistojet for the DelFFi formation flying mission. In: *IAF 65th International Astronautical Congress*, Canada (2014)
 14. Gronland, T.A., Palmer, K., Bejhed, J., Zaldivar-Salaverri, A., Rangsten, P.: CubeSat propulsion module with closed-loop thrust control. In: *28th Annual AIAA/USU Conference on Small Satellites*. UT, Logan (2014)
 15. Rackemann, N.J., Sanders, H.M., Van Vliet, L.D.: Design and development of a propulsion system for a Cubesat based on solid propellant cool gas generator technology. In: *IAF 57th International Astronautical Congress*, Valencia (2006)
 16. Coletti, M., Guarducci, F., Gabriel, S.B.: A micro PPT for Cubesat application: design and preliminary experimental results. *Acta Astronaut* **69**(3), 200–208 (2011)
 17. Gauer, M., et al.: PRECISE—development of a MEMS-based monopropellant μ chemical propulsion system. In: *AIAA/ASME/SAE/ASEE 48th Joint Propulsion Conference and Exhibit*, Atlanta (2012)
 18. Barral, S., et al.: First experimental characterization of a pulsed plasma thruster with non-volatile liquid propellant. In: *3AF Space Propulsion Conference*, Cologne (2014)
 19. Scharlemann, C.A., York, T.M.: Pulsed plasma thruster using water propellant, Part 11: Thruster operation and performance evaluation. In: *AIAA/ASME/SAE/ASEE 39th Joint Propulsion Conference and Exhibit*, Huntsville (2003)
 20. Brandenburg, J.E., Kline, J., Sullivan, D.: The microwave electro-thermal (MET) thruster using water vapor propellant. *IEEE Trans. Plasma Sci.* **33**(2), 776–782 (2005)
 21. James, K., Moser, T., Conley, J., Slostad, A., Hoyt, R.: Performance characterization of the HYDROS™ water electrolysis thruster. In: *29th Annual AIAA/USU Conference on Small Satellites*. UT, Logan (2015)
 22. Tittu Varghese, M., Zandbergen, B.T.C., Mihailovic, M., Creemer, J.F., Sarro, P.M.: A silicon-based MEMS resistojet for propelling CubeSats. In: *IAF 62nd International Astronautical Congress*, Cape Town (2011)
 23. Morana, B., Santagata, F., Mele, L., Mihailović, M., Pandraud, G., Creemer, J., Sarro, P.: A silicon carbide MEMS microhotplate for nanomaterial characterization in TEM. In: *MEMS 2011*, Cancun (2011)
 24. Ketsdever, A.D., Green, A.A., Muntz, E.P., Vargo, S.E.: Fabrication and testing of the free molecule micro-resistojet—initial results. In: *AIAA/ASME/SAE/ASEE 36th Joint Propulsion Conference and Exhibit*, Huntsville (2000)
 25. Ketsdever, A.D., Wadsworth, D.C., Muntz, E.P.: Gas-surface interaction model influence on predicted performance of micro-electromechanical system resistojet. *J. Thermophys. Heat Transf.* **15**(3), 302–307 (2001)
 26. Ketsdever, A.D., Lee, R.H., Lilly, T.C.: Performance testing of a microfabricated propulsion system for nanosatellite applications. *J. Micromech. Microeng.* **15**(12), 2254–2263 (2005)
 27. Wang, C., Zandbergen, B., Cervone, A., Chu, J.: Numerical studies on performance of free molecule micro-resistojet with ice propellant. In: *6th European Conference for Aeronautics and Space Sciences (EUCASS)*, Warsaw (2015)
 28. Micci, M.M., Ketsdever, A.D.: *Micropropulsion for Small Spacecraft*, vol 187. AIAA, New York (2000)
 29. Fearn, D.G.: Ion thruster thrust vectoring requirements and techniques. In: *International Electric Propulsion Conference*, Pasadena, pp. 1–115 (2001)
 30. King, W.H., Schnelker, D., Ward, J.W., Dulgeroff, C., Vahrenkamp, R.: Thrust vectoring systems. In: *Technical Report NASA CR-121142* (1972)
 31. Laser, D.J., Santiago, J.G.: A review of micropumps. *J. Micromech. Microeng.* **14**(6), R35–R64 (2004)
 32. Rangsten, P., Bejhed, J., Johansson, H., Bendixen, M., Jonsson, K., Grönland, T.A.: Advanced MEMS components in closed-loop micro propulsion applications. In: *26th Annual AIAA/USU Conference on Small Satellites*. UT, Logan (2012)