

 Open access • Book • DOI:10.1596/24691

## Greenhouse gases from geothermal power production — [Source link](#)

[Thrainn Fridriksson](#), [Almudena Mateos Merino](#), [Pierre Audient](#), [Ayse Yasemin Orucu](#)

**Published on:** 30 Apr 2016 - [Research Papers in Economics](#) (World Bank, Washington, DC)

**Topics:** [Geothermal power](#), [Geothermal energy](#), [Geothermal gradient](#), [Renewable energy](#) and [Base load power plant](#)

Related papers:

- [Geothermal power generation worldwide](#)
- [Global Geothermal Energy Scenario by 2040](#)
- [Producing electricity from geothermal energy](#)
- [Geothermal power generation : Global perspectives; U.S.A. and Iceland; technology, direct uses, plants, and drilling](#)
- [Economics of geothermal energy](#)

Share this paper:    

View more about this paper here: <https://typeset.io/papers/greenhouse-gases-from-geothermal-power-production-2drw4k74k1>

# GREENHOUSE GASES FROM GEOHERMAL POWER PRODUCTION



Public Disclosure Authorized

Public Disclosure Authorized

Public Disclosure Authorized

Public Disclosure Authorized



## ESMAP MISSION

**The Energy Sector Management Assistance Program (ESMAP) is a global knowledge and technical assistance program administered by the World Bank. It provides analytical and advisory services to low- and middle-income countries to increase their know-how and institutional capacity to achieve environmentally sustainable energy solutions for poverty reduction and economic growth. ESMAP is funded by Australia, Austria, Denmark, Finland, France, Germany, Iceland, Lithuania, the Netherlands, Norway, Sweden, and the United Kingdom, as well as the World Bank.**

Copyright © April 2016  
The International Bank for Reconstruction  
And Development / THE WORLD BANK GROUP  
1818 H Street, NW | Washington DC 20433 | USA

Energy Sector Management Assistance Program (ESMAP) reports are published to communicate the results of ESMAP's work to the development community. Some sources cited in this report may be informal documents not readily available.

The findings, interpretations, and conclusions expressed in this report are entirely those of the author(s) and should not be attributed in any manner to the World Bank, or its affiliated organizations, or to members of its board of executive directors for the countries they represent, or to ESMAP. The World Bank and ESMAP do not guarantee the accuracy of the data included in this publication and accept no responsibility whatsoever for any consequence of their use. The boundaries, colors, denominations, and other information shown on any map in this volume do not imply on the part of the World Bank Group any judgment on the legal status of any territory or the endorsement or acceptance of such boundaries.

The text of this publication may be reproduced in whole or in part and in any form for educational or nonprofit uses, without special permission provided acknowledgement of the source is made. Requests for permission to reproduce portions for resale or commercial purposes should be sent to the ESMAP Manager at the address below. ESMAP encourages dissemination of its work and normally gives permission promptly. The ESMAP Manager would appreciate receiving a copy of the publication that uses this publication for its source sent in care of the address above.

All images remain the sole property of their source and may not be used for any purpose without written permission from the source.

Written by | Þráinn Fridriksson, Almudena Mateos, Pierre Audinet, and Yasemin Orucu  
Energy Sector Management Assistance Program | The World Bank



## TABLE OF CONTENTS

	Acronyms and Abbreviations	ii
	Acknowledgements	iii
	Key Findings	1
1	GEOTHERMAL SYSTEMS AND UTILIZATION	5
2	GASES AND THE GEOTHERMAL CYCLE	7
	2.1. Gases in Geothermal Fluids	7
	2.2. Natural Sources and Sinks of CO <sub>2</sub> in Geothermal Systems	8
	2.3. Effects of Power Production on the CO <sub>2</sub> Budget of Geothermal Systems	11
3	GHG EMISSIONS FROM GEOTHERMAL POWER PLANTS	17
	3.1. Assessments of Plant Cycle GHG Emissions from Geothermal Projects	17
	3.2. Global and National Surveys on Operational GHG Emissions	18
	3.3. High Emission Outliers	19
4	TECHNICAL OPTIONS TO MITIGATE CO <sub>2</sub> EMISSIONS FROM GEOTHERMAL POWER PLANTS	21
	4.1. Energy Conversion Technologies and CO <sub>2</sub> Emissions	21
	4.2. Gas Sequestration Technologies	25
5	ASSESSING GHG EMISSIONS FROM GEOTHERMAL POWER PROJECTS	29
	5.1. Estimating Emission Factors from Greenfield Projects	31
	5.2. Estimating Emission Factors for Brownfield Projects	34
	5.3. Constraining Emission Factors for Existing Projects	35
	5.4. Estimating Plant Cycle Emission Factors for Geothermal Power Projects	35
6	ADDRESSING KNOWLEDGE GAPS THROUGH INVESTMENT PROJECTS	37
	6.1. Long-term Changes in GHG Emissions from Power Plants	37
	6.2. Effects of Production on GHG Emissions through Soil and Fumaroles	38
	6.3. Cost of GHG Capture and Treatment	38
	REFERENCES	41

### List of Figures and Tables

Figure	1	Approach to Define GHG Emission Factors from Greenfield Geothermal Projects	3
Figure	2.1	Natural Sources and Sinks of CO <sub>2</sub> in a Volcanic Geothermal System	11
Figure	2.2	Volcanic Geothermal System Processes Affecting CO <sub>2</sub> Emissions	12
Figure	2.3	CO <sub>2</sub> Emissions from the Reykjanes Geothermal System, Iceland	15
Figure	5.1	Emission Factors of Geothermal Power Compared to Fossil Fuel	30
Figure	5.2	Approach to Define GHG Emission Factors from Greenfield Geothermal Projects	32
Table	2.1	Typical Composition of Geothermal Gas	7
Table	4.1	Resource Temperature Ranges Suitable for the Different Energy Conversion Technologies	25

## ACRONYMS AND ABBREVIATIONS

ARPAT	Regional Environmental Protection Agency for Tuscany	LRSR	Liquid Redox Sulfur Recovery
Bar-a	Bar absolute (absolute pressure)	MW	Megawatt (in this report, MW refers to electric power)
Bar-g	Bar gauge (absolute pressure minus atmospheric pressure)	MW <sub>e</sub>	Megawatt electric power
CDM	Clean Development Mechanism	MW <sub>t</sub>	Megawatt thermal
EF <sub>GHG</sub>	Greenhouse Gas Emission Factor	NCG	Non-condensable gas
EOR	Enhanced Oil Recovery	ppm	Parts per million
g/kWh	Gram per kilowatt hour	ppm-V	Parts per million on volume basis
gCO <sub>2</sub> /kWh	Gram CO <sub>2</sub> per kilowatt hour	t/day	Metric tonne per day
gCO <sub>2,e</sub> /kWh	Gram CO <sub>2</sub> equivalent per kilowatt hour	US DOE	United States Department of Energy
GHG	Greenhouse gas	USD/t	United States dollar per metric tonne
LCA	Life Cycle Analysis		

All currency in United States dollars (USD or US\$), unless otherwise indicated.

## ACKNOWLEDGMENTS

This Interim Technical Note was prepared by Thráinn Fridriksson (Energy Specialist), Almudena Mateos (Energy Specialist), and Pierre Audinet (Senior Energy Economist) at the Energy Sector Management Assistance Program (ESMAP) of the World Bank. The note benefited from a thorough review process which refined its focus and content and drew upon wide ranging experience and expertise of World Bank specialists and a panel of external reviewers representing geothermal developers, technical practitioners, researchers, and other multilateral financial institutions. The internal peer reviewers were Peter Johansen (Senior Energy Specialist, GEE02), Karan Kapoor (Senior Energy Specialist, GEESO), and Rikard Liden (Senior Hydropower Specialist, GWAGS). The external review panel included: Ruggero Bertani (Director of Innovation and Sustainability, Enel Green Power, Italy), Yoram Bronicki (Former Director and Chairman of the Board of Directors of Ormat Technologies, USA), Annika Eberle (Engineering Researcher, National Renewable Energy Laboratory, USA), Karl Gawell (Executive Director, Geothermal Energy Associates, USA), Magnus Gehringer (CEO, Consent Energy, USA), Bill Harvey (Project Engineer, Power Engineers, USA), Garvin Heath (Senior Scientist, National Renewable Energy Laboratory, USA), Adonai Herrera (Senior Manager, Energy Efficiency and Climate Change, EBRD, Turkey), Mike Long (Senior Project Manager, Power Engineers, USA), Benjamin Matek (Industry Analyst and Research Project Manager, Geothermal Energy Associates, USA), Ed Mrozcek (Senior Scientist, GNS Science, New Zealand), Ann Robertson-Tait (Business Development Manager/Senior Geologist, GeothermEx, USA), Anna Wall (Energy Technologies Analyst, National Renewable Energy Laboratory, USA). Barbara Ungari and Maria Elisa Passeri (Consultants, GEEES) are acknowledged for their help with data collection and analysis.



## KEY FINDINGS

Geothermal is a renewable source energy that can be used directly for heating or for power production. Geothermal utilization, particularly power production, may result in some greenhouse gas (GHG) emissions. GHG emissions from geothermal power production is generally small in comparison to traditional base load thermal energy power generation facilities. This is mainly due to the fact that the large majority of installations draw their geothermal energy from geothermal reservoirs with low GHG concentrations. However, as the geothermal sector has expanded, a wider range of geothermal resources have been brought into exploitation, including geothermal systems with relatively high GHG concentrations in the reservoir fluid. There is a growing realization within the geothermal community that geothermal power plants can, in rare instances, release significant quantities GHG into the atmosphere.

This interim technical note presents an overview of the current knowledge on GHG emissions from geothermal systems and geothermal power plants, and gives guidance on how to assess GHG emissions from geothermal projects when this is required, depending on their stage of development. This note identifies critical knowledge gaps and presents recommendations as to how close these gaps and proposes an interim methodology to estimate GHG emissions from geothermal projects that financing institutions, such as the World Bank, intend to support. The plan is to update this note when the proposed methodology has been tested by application to actual projects and some of the current knowledge gaps have been closed as more information become available.

As a result of the relatively low GHG emission factors from geothermal power production, this issue has so far received limited attention in the scientific community. However, awareness is increasing as efforts are undertaken to curb GHG emissions globally. There are still a number of uncertainties that surround the understanding of GHG emissions from geothermal power production. One such example of uncertainty is with regards to trends in emissions over a plant's lifetime. Volumes, pressure, and composition of gases present in geothermal fluids that remain uncondensed after energy extraction fluids are monitored as part of normal geothermal plant operations. During the operation of geothermal power plants, there is a gradual decline in non-condensable gas (NCG) concentration in the reservoir fluid and, thus, gradually decreasing gas emissions can happen. This is largely a result of reinjection of gas free of geothermal brine into the peripheries of the reservoir. However, gradual gas decrease has not been systematically documented (in part because power plants do not have to publicly report such data). Another uncertainty is related to how the production of electricity from geothermal reservoirs may affect natural GHG emissions through the Earth's surface. GHG is continuously emitted naturally from geothermal reservoirs (i.e., without any drilling or power production taking place), diffusing through the soil and steam vents.

The national regulatory frameworks for carbon emissions from geothermal power production varies from country to country, reflecting the limited understanding of the effects of power production on natural surface emissions, the minuscule size of the geothermal sector compared to other segments of

the electricity generation sector, and its proportionately small (potential) GHG emissions contribution. In some countries, GHG emissions from geothermal power are not considered anthropogenic, in accord with the understanding that emissions from power plants are counterbalanced by reduction in surface emissions as described above. In other countries, geothermal power producers that emit more than a given volume of GHG per annum are now required by policies to monitor and report their emissions.

GHGs are naturally present in all geothermal fluids, and thus geothermal power production from intermediate to high temperature geothermal resources generally leads to some GHG release into the atmosphere. The dominant NCG in geothermal fluids is carbon dioxide (CO<sub>2</sub>), typically constituting more than 95 percent of the total NCG content. The other relevant GHG in geothermal fluids is methane (CH<sub>4</sub>), whose concentration is generally a few hundredths to a few tenths of a percent by mass, but can in rare cases make up more than 1.5 percent of the total gas (i.e., amounting to more than 30 percent of the GHG emissions as CH<sub>4</sub> traps thermal radiation more efficiently than CO<sub>2</sub>). However, the vast majority of available data on GHG emissions from geothermal power plants refers to CO<sub>2</sub> only. As a result, the discussion in this note on GHG emissions from geothermal power production is mainly focused on CO<sub>2</sub> emissions.

In 2001, the global average estimate for operational GHG emissions from geothermal power production was 122 gCO<sub>2</sub>/kWh, based on a survey involving emissions from power plants that constitute more than 50 percent of the geothermal capacity installed worldwide. Available data from the United States and New Zealand are consistent with these global emission values, resulting in average figures of 106 g CO<sub>2</sub>/kWh (in 2002) and 123 g CO<sub>2</sub>e/kWh (in 2012), respectively. The country-wide weighted average emission estimate for Iceland is lower 34 g/kWh (in 2013), and the corresponding value for Italy is higher at 330 g CO<sub>2</sub>/kWh (in 2013).

In a few exceptional cases, the emission from geothermal power plants can be significantly higher than the averages above, even above the values of thermal fossil-fueled power plants (which can reach 1,030 g CO<sub>2</sub>/kWh for a subcritical circulating fluidized bed coal-fueled power plant and 580 g CO<sub>2</sub>/kWh for an open cycle gas-fueled power plant). The most extreme reported GHG emission values, 900 to 1,300 g CO<sub>2</sub>/kWh are from power plants located in the Menderes and Gediz grabens in South West Turkey. Fairly high values have also been reported in some power plants from Mount Amiata, Italy, and Ngawha, New Zealand. Such high GHG emissions seem to be restricted to high temperature geothermal reservoirs located in carbonate rich rocks, which are a rare occurrence.

This note proposes a way to estimate future emission factors for geothermal projects under development. For instance, if a pumped binary power plant is planned, the emission factor will be 0. Projects using other energy conversion technologies will result in some emissions. For projects where wells have been drilled and tested, formulas are provided to compute emission factors based on the chemical composition of the geothermal fluid and the design parameters of the power plant. For projects located in the vicinity of existing power plants in analogous geologic settings, emission factors from the existing plants can be used.

Where no such analogs are available, emission factors can be roughly estimated based on the expected geology of the geothermal reservoirs. For instance, for power projects located where carbonate rocks are expected at reservoir level, emission factors can be estimated at 790 g CO<sub>2</sub>e/kWh. If volcanic rocks are expected or where no such information is available, future emissions are estimated to be equal to the global average or 128 g CO<sub>2</sub>e/kWh. This approach is summarized by Figure 1.

If Plant Cycle emissions are to be included, it is recommended that a Plant Cycle GHG emission factor of 10 g/kWh is used for a project lifetime of 30 years.

The entity financing or implementing financing to develop a given geothermal electricity production project is best suited to gather data that could help close some of the existing knowledge gaps related to GHG emissions from geothermal power production. First, GHG emission data should be systematically collected from geothermal power projects in order to monitor the changes in GHG

**FIGURE 1**  
Approach to Define GHG Emission Factors from Greenfield Geothermal Projects

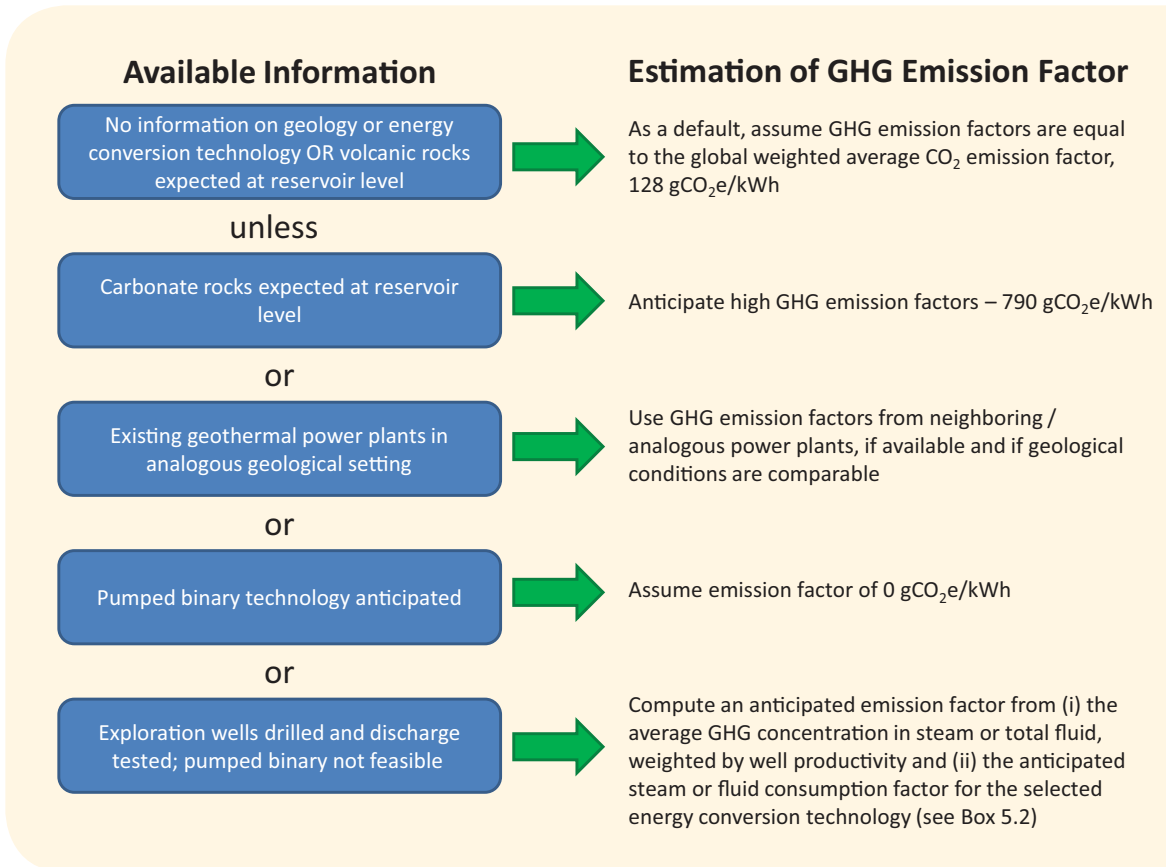

emission factors over time. Second, it is also recommended that, when possible, funding should be provided for baseline studies of surface GHG emissions in geothermal areas before geothermal power production commences, followed by periodic surveys once production has started. This will provide much needed data on the effects of geothermal power production on gas emissions through the surface. Finally, project sponsors are encouraged to conduct a feasibility study of GHG capture and treatment options, in particular for geothermal power projects that are likely to result in GHG emissions in excess of the grid emission factor in a given country. This will encourage the use of GHG capture technologies, where economically feasible, and provide more detailed information about the cost of these technologies.

Divided into two parts, this report complements the World Bank Guidance Manual for Greenhouse Gas Accounting for Energy Investment Operations (World Bank, 2015) by presenting methods to predict and estimate GHG emission factors for geothermal projects at different stages of development.

**Part I** is a review of the existing knowledge on GHG emissions from geothermal systems and power plants, focusing on the following questions:

- What is the average and range of GHG emissions from geothermal power plants worldwide?
- What are the geological factors that affect GHG emissions from geothermal power plants?
- Do GHG emissions from geothermal power plants change over time?
- Does geothermal power production affect the amount of GHG released through natural pathways from the geothermal system?
- Does the energy conversion technology affect GHG emissions?
- What are the options for GHG capture from geothermal power plants?

**Part II** provides guidance on methods to quantify GHG emissions from geothermal power projects.

## GEOTHERMAL SYSTEMS AND UTILIZATION

A geothermal system can be defined as a thermal anomaly in the Earth's upper crust where convecting fluid transfers heat from a heat source at depth towards the surface. Geothermal systems range in reservoir temperature from near ambient conditions to over 350°C. Geothermal systems are commonly classified based on the reservoir temperature into low (<100–150°C), intermediate (between 100–150°C and 200°C) and high temperature (>200°C) geothermal systems.<sup>1</sup>

The division into low, intermediate, and high temperature geothermal systems reflects the different uses of geothermal depending on the resource temperature. Low temperature systems are suitable for direct applications, such as space heating, drying, spa applications, etc. Intermediate and high temperature systems are suitable for power production, using different energy conversion technologies. Power production from intermediate temperature geothermal systems can be accomplished using binary technology, whereas conventional condensing turbines are most commonly used for power production from high temperature systems (ESMAP, 2012).

High temperature geothermal systems can also be classified based on the dominant state of the fluid in the reservoir (i.e., as liquid-dominated or vapor-dominated systems). Purely vapor-dominated (dry steam) systems are less common than liquid dominated systems but steam dominated zones or “steam caps” within liquid-dominated reservoirs in production are not uncommon (see Box 2.1 and Section 2.3.1). This has implications for the presence of geothermal gases as they partition preferentially into the vapor phase. Higher gas emissions can be expected from geothermal power plants producing from vapor-dominated systems or steam zones as opposed to fully liquid-dominated reservoirs. Low and intermediate temperature geothermal systems are always liquid dominated.

Geothermal systems can also be classified by their geological nature. Volcanic geothermal systems are the most common high temperature geothermal systems. These systems are characterized by a volcanic heat source, such as hot intrusions or magma. Volcanic geothermal systems are found in volcanically active areas along tectonic plate boundaries and also in association with intraplate volcanism in some cases. Not all volcanic systems develop geothermal systems. Low temperature systems are commonly convective fracture controlled systems where water circulates in deep fractures, mining the heat from the rocks at depth. These fracture controlled systems generally do not have a magmatic heat source but can still have intermediate to high temperatures when located in areas of high heat flow. The geothermal systems in the Basin and Range<sup>2</sup> area of the Southwest United States and the Aegean region of Turkey are examples of hot fracture controlled systems in areas of high heat flow due to extensional tectonics and resulting crustal thinning.

Utilization of low temperature geothermal systems does not generally result in significant gas emissions. This is due to the fact that the gas content in geothermal fluids is to some degree correlated with reservoir temperature, so low temperature fluids are generally gas poor. Furthermore, utilization of low temperature fluids quickly becomes uneconomical when gas content is significant (see Section 6.1).

As a result, this note focuses on gas emissions from medium and high temperature geothermal resources used for power production.

## ENDNOTES

<sup>1</sup>More information on the different classifications schemes for geothermal systems can be found at the IGA website ([http://www.geothermal-energy.org/what\\_is\\_geothermal\\_energy.html](http://www.geothermal-energy.org/what_is_geothermal_energy.html))

<sup>2</sup>The term Basin and Range refers to a geographic area in the Southwest United States and Northwest Mexico that is characterized by crustal extension, which has resulted in the formation of long narrow mountain ridges separated by flat valleys.

## GASES AND THE GEOTHERMAL CYCLE

### 2.1. GASES IN GEOTHERMAL FLUIDS

Gases are naturally present in geothermal fluids. Geothermal gases are dissolved in the liquid phase at the reservoir level, but where steam is present the gases partition preferentially into the steam phase. Common geothermal gases are CO<sub>2</sub>, H<sub>2</sub>S, H<sub>2</sub>, N<sub>2</sub>, CH<sub>4</sub>, NH<sub>3</sub>, and Ar, but other gases are also present in trace amounts. A common compositional range of geothermal gases is shown in Table 2.1.

Table 2.1 illustrates how CO<sub>2</sub> is generally the dominant geothermal gas, typically constituting more than 95 percent of the total gas. Other significant gases are H<sub>2</sub>S and N<sub>2</sub>, the weight of which, in rare cases, can constitute several percentage points of the total geothermal gas. Other gases are generally found in low concentrations in the order of a few percent to a fraction of a percent.

CO<sub>2</sub> and CH<sub>4</sub> are the only relevant GHG species in geothermal fluids. While CO<sub>2</sub> is the most abundant GHG, CH<sub>4</sub> is generally present in small concentrations as well. However, due to its relatively strong global warming potential,<sup>3</sup> CH<sub>4</sub> may have a significant contribution to the overall GHG emissions from geothermal power plants. Unfortunately, data on CH<sub>4</sub> emissions from geothermal power plants are not available for all systems for which there are CO<sub>2</sub> emission data. As a result, it is difficult to assess the CH<sub>4</sub> contribution to GHG emissions from geothermal power production to the same extent as is possible for CO<sub>2</sub>. Available data suggest that CH<sub>4</sub> emission, in terms of CO<sub>2</sub> equivalents, ranges from a fraction of a percent to more than one-fourth of the total GHG emissions in the most extreme cases.<sup>4</sup> As a result, it can be assumed that the magnitude of the global warming effect of CH<sub>4</sub> emissions from geothermal power plants is generally smaller than that of CO<sub>2</sub>, but CH<sub>4</sub> emissions may represent a significant fraction of the total GHG emissions in some cases. However, since data on CH<sub>4</sub> emissions from geothermal power plants is limited, the discussion below will focus on CO<sub>2</sub>.

In the context of geothermal power production, the geothermal gases are commonly referred to as non-condensable gases (NCGs) as they do not condense at the same physical conditions as water vapor but remain in the gas phase. NCGs have a negative effect on the efficiency of the energy conversion process and need to be removed from the system (either from the condenser or the heat

**TABLE 2.1**  
Typical Composition of Geothermal Gas (weight % dry gas)

	CO <sub>2</sub>	H <sub>2</sub> S	H <sub>2</sub>	CH <sub>4</sub>	NH <sub>3</sub>	N <sub>2</sub>	AR
Median	95.4	3.0	0.012	0.15	0.29	0.84	0.02
Maximum	99.8	21.2	2.2	1.7	1.8	3.0	0.04
Minimum	75.7	0.1	0.001	0.0045	0.005	0.17	0.004

*Note | Based on 15 representative steam analyses from high temperature systems in Europe, North-America, Central-America, Africa, Asia and Oceania (from Arnórsson et al., 2007).*

exchangers, see section 6.1). Gas removal systems add to the capital costs of geothermal power plants and can, in some cases, also consume a considerable amount of the plant's power production. These systems are designed to cope with a specific range of NCG content in the steam or the total fluid. Accurate estimation of the NCG content in the geothermal fluid, thus, is one of the most critical design parameters for geothermal power plants.

## 2.2 NATURAL SOURCES AND SINKS OF CO<sub>2</sub> IN GEOTHERMAL SYSTEMS

Different geothermal gases have different origins and CO<sub>2</sub> in particular can derive from three main sources:

- 1 | A small fraction of the CO<sub>2</sub> in a geothermal reservoir may have **the same origin as the geothermal fluid itself**. This is the CO<sub>2</sub> that is dissolved in the recharging fluid, sea water, or meteoric water when it enters the geothermal system. This is generally an insignificant fraction of the total CO<sub>2</sub> dissolved in geothermal fluids.
- 2 | A large fraction of the CO<sub>2</sub> in geothermal fluids may be derived from **the host rock of the geothermal system**. Igneous rocks, which are the dominant rock type in volcanic geothermal systems, contain a small amount of carbonate that is released due to chemical interactions between the rocks and the fluids. Therefore, the concentrations of CO<sub>2</sub> in volcanic geothermal systems can be moderate if rock dissolution is the major source of CO<sub>2</sub> in the fluid. This applies, for instance, to the Reykjanes, Hellisheidi, and Nesjavellir systems in Iceland (see Box 2.1). Other rock types may release larger quantities of CO<sub>2</sub> into the geothermal fluids, such as carbonate rocks, which have carbonate as a major constituent. Such rocks may release large amounts of CO<sub>2</sub> to the geothermal fluids upon dissolution or through metamorphic processes at high temperatures (see Box 2.2). Carbonate-hosted high temperature geothermal systems are not common but they do occur (notably in the Tuscany region of Italy and western Turkey) and are characterized by significantly higher CO<sub>2</sub> fluid concentrations than other geothermal reservoirs. Other types of sedimentary rocks contain variable amounts of carbonate, resulting in a range of CO<sub>2</sub> concentrations in the geothermal fluids.
- 3 | CO<sub>2</sub> may enter the geothermal reservoir from below, either from deep crustal or mantle sources or from magma bodies, which are **the heat sources of many volcanic geothermal systems**. Magmatic CO<sub>2</sub> can enter geothermal reservoirs in pulses related to magmatic intrusions such as in Krafla, Iceland (see Box 2.1), or more continuously such as in Mt. Amiata, Italy, or Ohaaki, New Zealand (Haizlip et al., 2013).

The sinks of geothermal CO<sub>2</sub> include precipitation of carbonate minerals in or above the geothermal reservoir, emission to the atmosphere through steam vents or diffusely through the soil, and dissolution in ground waters after ascent from the geothermal reservoir. Geothermal steam emitted from steam vents may, in some cases, be a good indicator of the composition of the gas in the reservoir. However, secondary processes, such as steam condensation, boiling of shallow ground waters, and chemical reactions between gases in the steam and the bed rock and soil, may significantly alter the steam



### BOX 2.1

#### CO<sub>2</sub> Emissions from Icelandic Power Plants, 1977 to Present

Total CO<sub>2</sub> emissions from Icelandic power plants and emissions from individual plants shown in the figure below. This figure highlights two important points. First, it shows that emissions from individual systems in Iceland span a wide range. Second, it illustrates that emissions from individual systems have changed significantly over time. Emissions from the most recent power plants, Nesjavellir, Hellisheidi, and Reykjanes, have historically been under 60 g/kWh and in the recent years have fallen to a range from 15 to 30 g/kWh. Annual average emissions from the other three power plants have been between 100 and 470 g/kWh throughout much of their history but in recent years have been lower, or around 50 g/kWh for Krafla and Bjarnarflag and around 100 g/kWh in Svartsengi.

All the Icelandic geothermal power plants are producing from basalt-hosted geothermal systems (Arnórsson, 1995) so the variation in gas emissions cannot be attributed to different rock compositions. Similarly, the levels

#### CO<sub>2</sub> Emission from Geothermal Power Plants in Iceland, 1977–2013

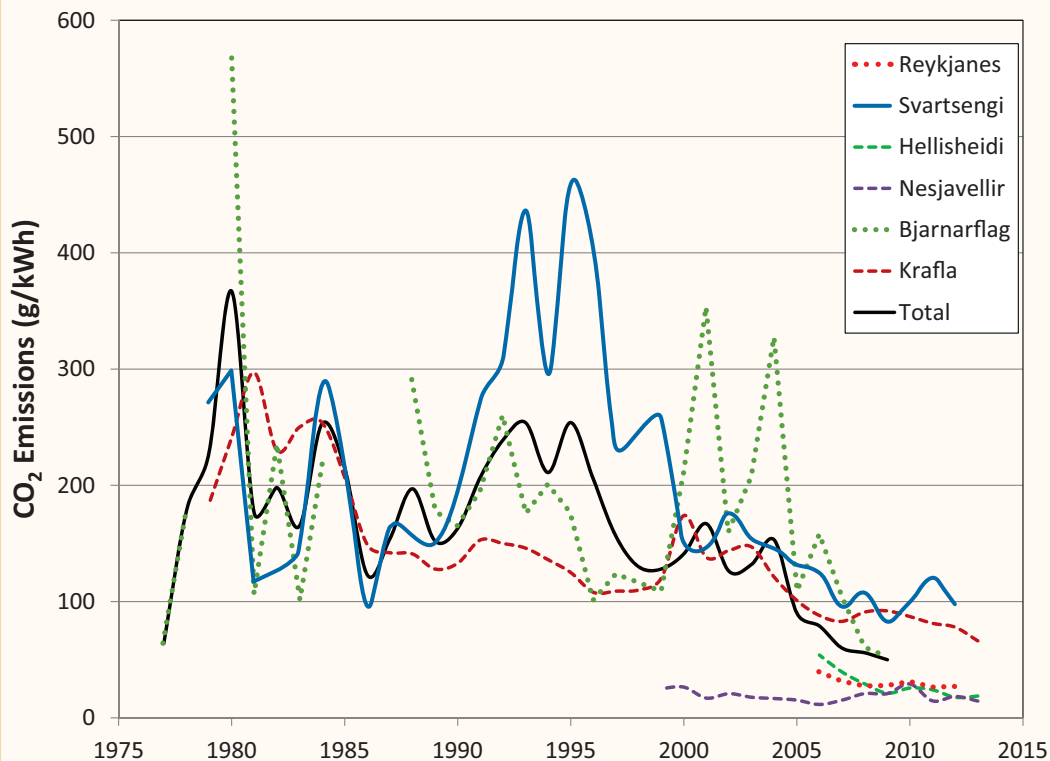

Source | Data from Baldvinsson et al., 2009 and personal communications with Landsvirkjun, Reykjavik Energy, and HS Orka.

### BOX 2.1 (CONTINUED)

of gas emissions cannot be attributed to the origin of the fluid; the geothermal fluid in Reykjanes is of seawater origin, while in Svartsengi, the fluid is two-thirds seawater and one-third meteoric water. The fluid in the other four systems is of meteoric origin. The different character of the gas emissions in these six systems can be attributed to different processes that have taken place in these systems—degassing of shallow magmatic intrusions in Krafla and Bjarnarflag, and the formation of a steam cap in the Svartsengi field.

The highest emission for individual plants was recorded in 1980 when emissions from Bjarnarflag reached 569 g/kWh. In 1981, the highest emission values for Krafla were recorded at 297 g/kWh. High gas concentrations in steam in Bjarnarflag and Krafla in the early 1980s resulted from influx of magmatic CO<sub>2</sub> that was directly related to the Krafla fires, volcanic events that started in 1975 and lasted until 1984 (Ármansson et al., 2015). Since 1984, CO<sub>2</sub> emissions from these two power plants have gradually decreased, with a few erratic exceptions.

In Svartsengi, CO<sub>2</sub> emissions increased from 100 to 160 g/kWh in the late 1980s to 300 to 470 g/kWh in the mid-1990s. Since 2000, the emissions from Svartsengi have gradually decreased and have now levelled off at around 100 g/kWh. The reason for the peak in CO<sub>2</sub> emissions in Svartsengi in the 1990s was the increased production from a steam cap that formed at shallow levels in the North East part of the field in the mid-1980s. The gas concentration in the steam that formed in the steam cap was about an order of magnitude higher than in steam formed by flashing geothermal brine in other parts of the field (5 wt% compared to 0.5 wt%; Bjarnason, 1996). Decreasing emissions from Svartsengi in the last 15 years is a result of gradual decrease in CO<sub>2</sub> concentration in the steam cap to less than 2 wt% in recent years (Óskarsson, 2014) and of increased production from other parts of the reservoir relative to the steam cap.

### BOX 2.2

#### Thermal Decomposition of Carbonate Rocks

Carbonate rocks are common sedimentary rocks, composed mainly of calcite or aragonite (CaCO<sub>3</sub>) or dolomite (CaMg(CO<sub>3</sub>)<sub>2</sub>). Carbonate rocks are biogenic sedimentary rocks formed in relatively shallow waters from skeletal fragments of marine organisms. Marble forms by recrystallization of carbonate rocks at high temperatures and pressures, and is referred to as metamorphic carbonate rock.

When carbonate rocks are exposed to relatively high temperatures at relatively low pressure, such as near shallow magma intrusions or in the roots of high temperature geothermal systems, the carbonate minerals react with silicates to form calcium or magnesium silicates and CO<sub>2</sub> gas. One example of such a thermal decomposition reaction is:



Thermal breakdown of carbonate rocks in the roots of geothermal systems can result in the formation of CO<sub>2</sub> gas that migrates up to the geothermal reservoir. Similarly, equilibrium between calcite, quartz, and wollastonite in high temperature geothermal reservoirs can result in high concentrations of dissolved CO<sub>2</sub> in the geothermal fluid.

**FIGURE 2.1**

Natural Sources and Sinks of CO<sub>2</sub> in a Volcanic Geothermal System

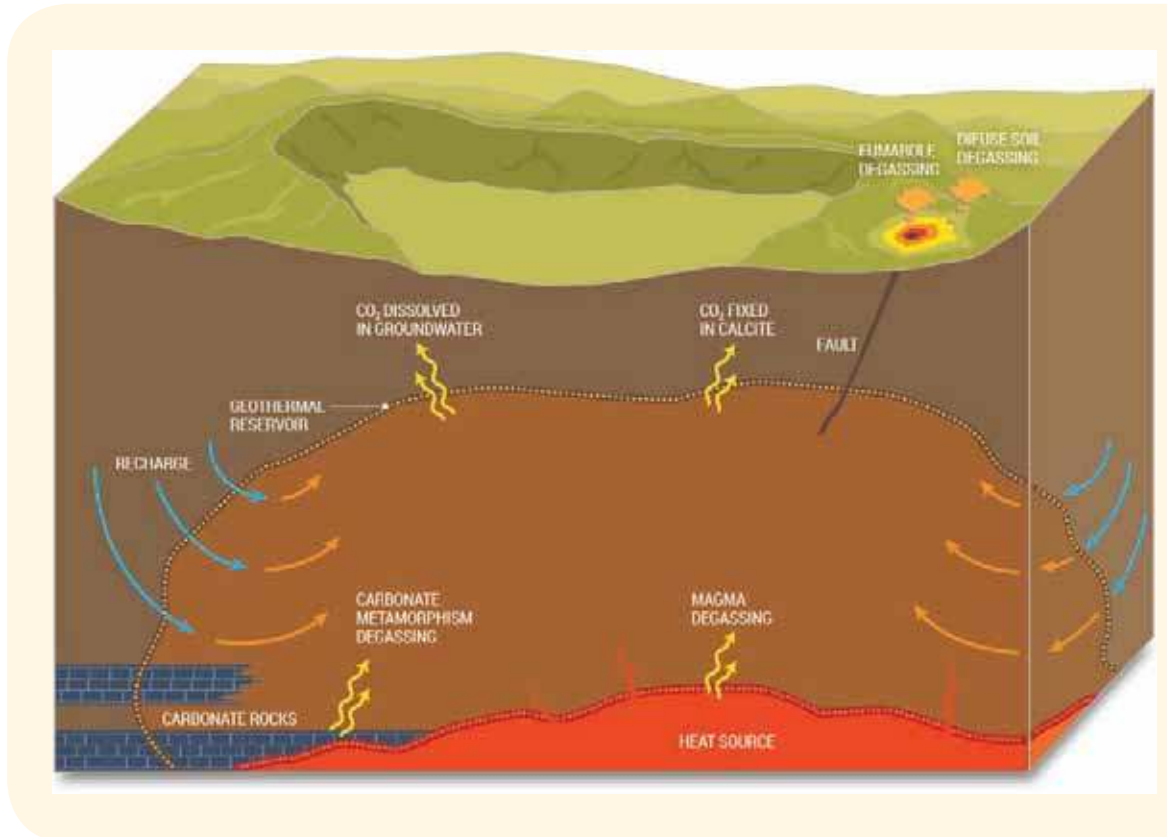

composition (Arnórrsson et al., 2007). Chemical reactions between CO<sub>2</sub> in the geothermal fluids and silicate and carbonate minerals may control the concentration of dissolved CO<sub>2</sub> in the fluid, essentially buffering the CO<sub>2</sub> concentration in the reservoir fluid to a certain level at a given temperature. These reactions are relatively slow to equilibrate and, as a result, the mineralogical control over the concentration of dissolved CO<sub>2</sub> in geothermal fluids does not always apply (i.e., the CO<sub>2</sub> concentration in the reservoir fluid can in some cases be either higher or lower than dictated by the mineralogical equilibria). Figure 2.1 shows a schematic diagram of a volcanic geothermal system illustrating the different natural sources and sinks of CO<sub>2</sub>.

### 2.3. EFFECTS OF POWER PRODUCTION ON THE CO<sub>2</sub> BUDGET OF GEOTHERMAL SYSTEMS

Extraction of fluid from high temperature geothermal reservoirs affects the balance between sources and sinks of CO<sub>2</sub> in a complex way that can evolve over time and space. The most important processes are linked to steam cap formation, the effects of reinjection of gas-depleted brine after

**FIGURE 2.2**

Volcanic Geothermal System Processes Affecting CO<sub>2</sub> Emissions

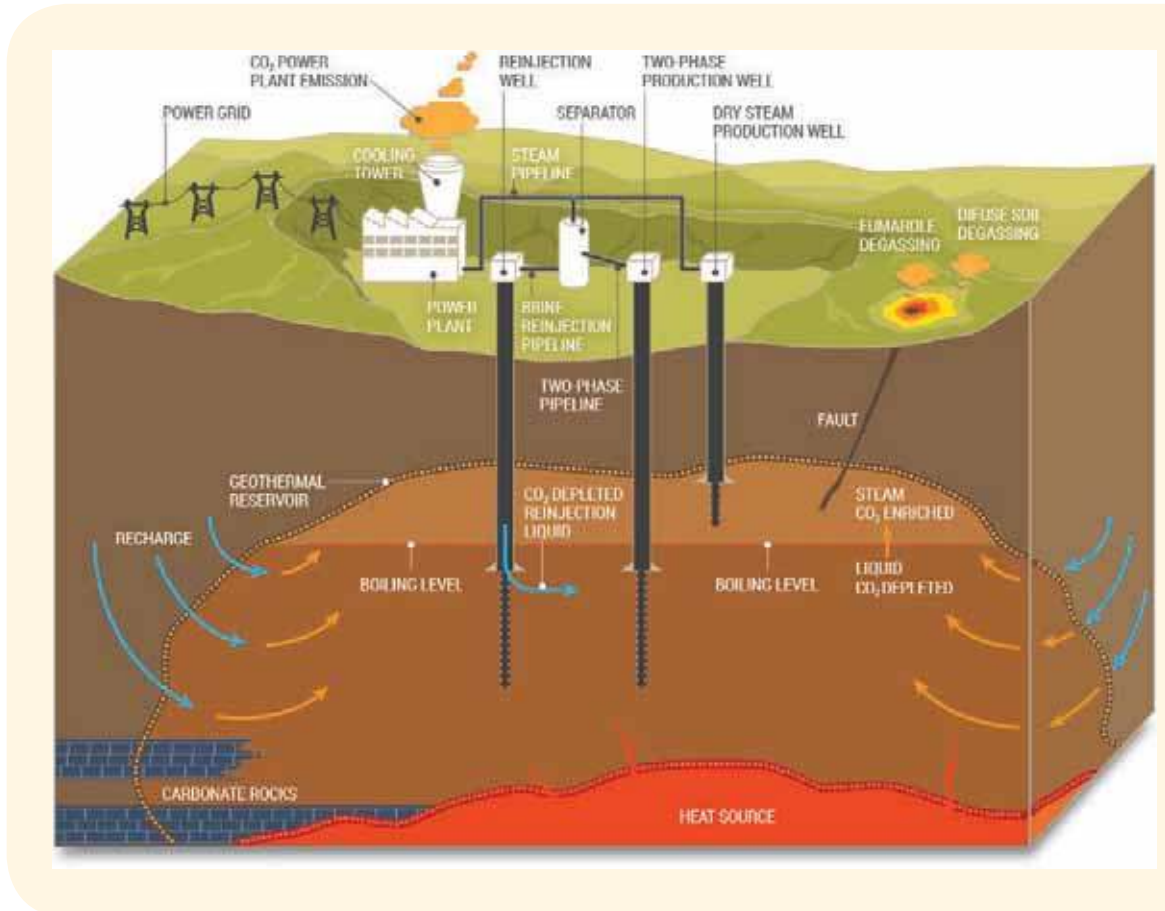

power production, and the effects on surface activity (e.g., fumaroles, steaming grounds, etc.) as illustrated in Figure 2.2.

### 2.3.1. Steam Cap Formation

Large scale removal of fluids as a result of geothermal power production may lead to reduced pressure in the reservoir. The pressure decrease or “drawdown” lowers the boiling level<sup>5</sup> in the reservoir and increases the volume of the reservoir above the boiling level, resulting in increased boiling. When this happens, the part of the reservoir above the boiling level becomes vapor dominated. Because dissolved gases partition preferentially to the vapor phase, this process leads to the formation of steam with relatively high gas concentrations while the reservoir liquid affected by this

boiling is left depleted of geothermal gas, including CO<sub>2</sub>, to some degree. This process, sometimes referred to as a steam cap or steam zone formation, may result in increased gas concentrations in steam from the steam cap but decreased gas concentrations in steam produced from the deeper, liquid dominated part of the reservoir (c.f. Ármannsson et al., 2005; Glover and Mroczek, 2009). Steam caps do not form in all geothermal systems and even when they do form, they may not have very high gas concentrations.

Steam cap formation may have different effects on the gas concentration in the steam produced from the reservoir, depending on the production strategy. The net effect of a steam cap formation on the CO<sub>2</sub> emissions from a given field will depend, to some degree, on the ratio of production from deeper and shallower levels.

The gas concentration in steam caps may decrease with time. This has been observed in several places such as in Svartsengi, Iceland (see Box 2.1), and Mount Amiata, Italy (Barelli et al., 2010). These changes are gradual, occurring over years.

It is difficult to take these processes into account when assessing future emissions from a geothermal power project. It is both difficult to predict whether a steam cap will form in a given reservoir and how the gas concentration in the steam cap will evolve. Hence, this process should not be taken into account when emissions are estimated, *ex ante*, in preparation of investment projects.

### 2.3.2. Impact of Reinjection

Reinjection of geothermal fluids after heat extraction is a common practice worldwide. Reinjection started as a disposal method but is now recognized as an important tool for reservoir management (Stefánsson, 1997; Kaya et al., 2011) as it helps maintain high reservoir pressures. Most commonly, the reinjection liquid is separated geothermal brine with or without condensate. In some steam-dominated reservoirs, surface waters are used for injection (Kaya et al., 2010).

In flash-steam geothermal power projects, the brine is separated from the steam phase. The gas partitions into the steam phase and the brine is left effectively gas free. Only a very small fraction of the gas dissolves in the condensate. The reinjected fluids (i.e., the brine and sometimes the condensate), thus, are characterized by very low gas concentrations and will tend to dilute the reservoir fluid with respect to dissolved gases. Injection management is an important issue in geothermal development. Injection wells are located close enough to the production zone to provide recharge and pressure support to the reservoir, but far enough from the production zone to allow the injected fluid to become sufficiently heated on the way back to the production zone (driven by the pressure differential between the injection zone and the production zone). Return of reinjected fluid may have a positive effect on the gas concentration in the produced steam (i.e., resulting in gradual decrease of gas concentrations<sup>6</sup> in the geothermal reservoir fluid and lowering emission factors with time).

The relationship between reinjection and gas concentrations may be more complex in steam-dominated reservoirs, even if the reinjected water is gas depleted. Reports from the Geysers field in California indicate that gas concentrations in steam produced from different parts of the reservoir

may either increase, decrease, or remain constant in response to injection of surface waters into the reservoir (Klein et al., 2009; Beall et al., 2007).

As the available information on the effect of reinjection on gas content of geothermal reservoir fluids is limited and not quite unequivocal, it cannot be assumed that gas concentrations in geothermal reservoir fluids will decrease with time when future emissions from geothermal projects are assessed. However, if more project data were available, it might be possible to make a rough estimate of how the gas concentrations in geothermal fluids would evolve with time, particularly for projects using reservoirs that are already in production.

### 2.3.3. Surface Activity

Pressure reduction in high temperature reservoirs due to production, as mentioned above, can lead to increased boiling in the reservoir. Increased boiling in the reservoir, in turn, can lead to increased surface activity. Examples of this are increased steam flow through fumaroles, increased soil temperature, and increased extent of hot ground. This may be a common phenomenon but it has only been quantitatively documented in a few places. So far, three studies have attempted to quantify the effects of power production on geothermal surface activity in Wairakei and Ohaki, New Zealand (Allis, 1981; Rissman et al., 2012) and Reykjanes, Iceland (Fridriksson et al., 2010; Óladóttir and Fridriksson, 2015). In the Karapiti area in Wairakei, the surface heat flow (i.e., loss of heat through the ground-air interface—heat loss can be used as a proxy for CO<sub>2</sub> flow through the surface) increased by an order of magnitude, from 40 MWt to 420 MWt, between 1958, when the first unit was commissioned, and 1964 (Allis, 1981). By 1978, the surface heat flow had declined to about 220 MWt and has not changed significantly since then (Glover et al., 2001; Glover and Mroczek, 2009).

At Reykjanes, Iceland, a 100 MWe power plant was commissioned in 2006. Figure 2.3 shows the evolution of the CO<sub>2</sub> emissions from the Reykjanes system from 2004 through 2014. The CO<sub>2</sub> diffuse emissions through the soil were about 13 t/day in 2004 and 2005 but increased after the commissioning of the power plant to 18.5 t/day in 2007 (Fridriksson et al., 2010, 2015). Since then, the CO<sub>2</sub> emissions through the soil have gradually increased to 51 t/day in 2013 (Óladóttir and Fridriksson, 2015). The CO<sub>2</sub> emissions from the power plant have decreased by almost 25 percent from 2007 to 2014, but the total emissions from the system continues to increase because of the continuous increase in diffuse degassing emissions.

Rissmann et al. (2012) reported a 70 percent increase in heat flow in the Western part of the Ohaaki geothermal field in New Zealand after 20 years of production. No change in heat flow was noticed in the Eastern part of the field. It, thus, can be concluded that the total increase in heat flow through soil, and (by proxy) CO<sub>2</sub> emission through soil from the system as a whole, was approximately 35 percent over a period of 20 years. Increase in heat flow and CO<sub>2</sub> emissions from the surface is likely to be particularly pronounced in systems where the pressure drop is abrupt in response to production and where the geothermal reservoir is connected to the surface (i.e., where geothermal manifestations are abundant). Unfortunately, very few studies have allowed quantification of this effect.

**FIGURE 2.3**

CO<sub>2</sub> Emissions from the Reykjanes Geothermal System, Iceland

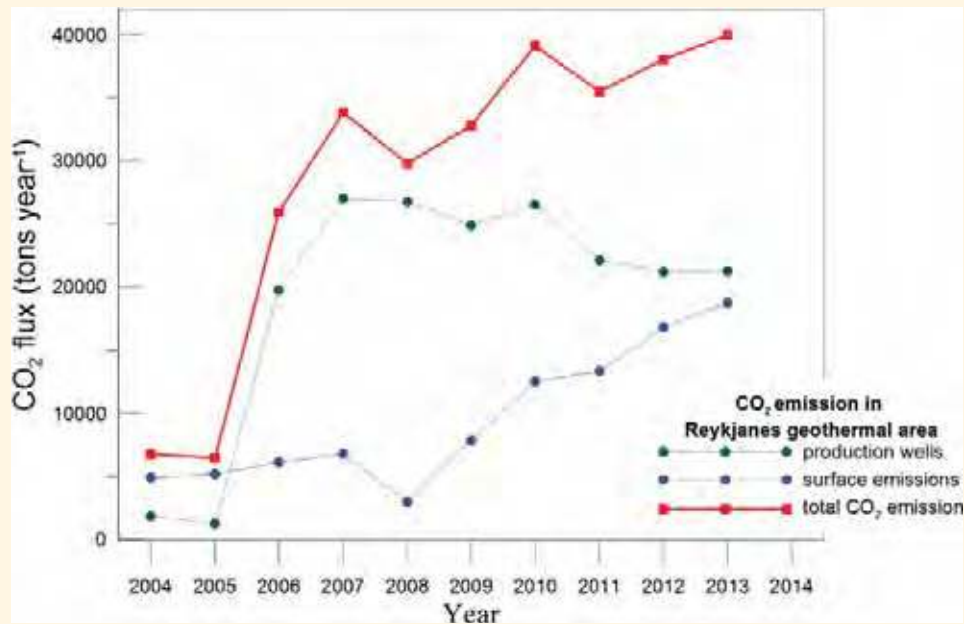

Note | Red curve show the combined emissions from power production (green) and diffuse CO<sub>2</sub> degassing through surface  
Source | Modified from Óladóttir and Fridriksson (2015).-

In contrast to the above observations from Wairakei and Reykjanes, Bertani and Thain (2002) argue that geothermal power production may actually cause a decrease in gas emissions through natural pathways from geothermal reservoirs. Consequently, they argue that “a very strong case can be made for subtracting the predevelopment natural emission rate from the rate being released by the operation of the geothermal development” (p. 2). In support of this, they proffer that CO<sub>2</sub> emissions through natural pathways (i.e., soil and fumaroles) have noticeably and measurably decreased in Larderello as a result of geothermal power production from that field. These observations of decreased surface activity at Larderello are supported by pictures and descriptions from travelers that visited these areas prior to development. According to these accounts, the entire Larderello area was covered by active surface manifestations such as fumaroles, boiling pools, and steaming grounds, earning it the name Devil’s Valley. Over the last several decades, power production from the Larderello system has brought about pressure decrease in the reservoir and, as a result, the natural degassing from the system has almost completely ceased (R. Bertani, personal communication). Similarly, Frondini et al. (2009), citing Sammarco and Sammarco (2002), suggest that geothermal power production at Mount Amiata, Italy, may have resulted in decreased natural gas emissions at that site.

Due to the limited number of studies that have directly measured the effect of geothermal power production on CO<sub>2</sub> emissions through natural pathways, it is not possible to make general statements about the magnitude of this effect, which is likely to vary greatly from one site to another. It is also possible that steam-dominated reservoirs respond differently to power production as compared to liquid-dominated reservoirs as suggested for Larderello by Bertani and Thain (2002). The relationship between emissions through soil and fumaroles and geothermal power production needs to be studied in more locations in order to better understand the underlying processes. As a result, this effect should not be taken into account when estimating future GHG emissions from geothermal power projects until more data (based on direct CO<sub>2</sub> flux measurements) become available.

## ENDNOTES

<sup>3</sup>The 100-year global warming potential of CH<sub>4</sub> relative to CO<sub>2</sub> is 25 (see Intergovernmental Panel on Climate Change, IPCC: [http://www.ipcc.ch/publications\\_and\\_data/ar4/wg1/en/ch2s2-10-2.html](http://www.ipcc.ch/publications_and_data/ar4/wg1/en/ch2s2-10-2.html)). This means that in terms of global warming effect, each tonne of CH<sub>4</sub> emitted is equivalent to 25 tonnes of CO<sub>2</sub>. Emissions of CH<sub>4</sub> are commonly presented in terms of grams carbon dioxide equivalent per kilowatt hour (gCO<sub>2</sub>e/kWh).

<sup>4</sup>CH<sub>4</sub> emissions from the Reykjanes and Svartsengi power plants in Southwest Iceland range from 0.1 to 0.25% of the total GHG emissions (Óskarsson et al., 2014; Óskarsson, 2013), whereas the contribution of CH<sub>4</sub> to the total GHG emissions from the nearby Hellisheidi and Nesjavellir power plants are of the order of 1.5 to 4% and 3 to 9%, respectively (unpublished data from Reykjavik Energy). Data from New Zealand (New Zealand Ministry for the Environment, 2013), show that CH<sub>4</sub> accounted about 16% of the total CO<sub>2</sub> equivalent emissions from geothermal power plants in that country in 2012. The CH<sub>4</sub> content in terms of CO<sub>2</sub> equivalents (computed from 15 gas analyses referred to in Table 2.1) range from 0.1 to 30% of the total GHG content with a median value is 3.7%.

<sup>5</sup>The boiling level in a geothermal reservoir is the depth at which the liquid is in equilibrium with water. Below the boiling level, the reservoir fluid is liquid but liquid and vapor coexist above the boiling level.

<sup>6</sup>Benoit and Hirtz (1994) reported that gas emissions from the Dixie Valley power plant in Nevada, USA, decreased from 69 g/kWh in 1988 to 42 g/kWh in 1992 as a result of returning reinjection water to the production wells. The same has occurred in Kizilidere, Turkey, where the CO<sub>2</sub> concentration in the reservoir fluid decreased by 15% from 1984 to 2000 (Haizlip et al., 2013). Similarly, Glover and Scott (2005) report 16 to 30% decrease in CO<sub>2</sub> content of the reservoir fluid in Ngawha, New Zealand, due to reinjection after only 6 years of production.



## GHG EMISSIONS FROM GEOTHERMAL POWER PLANTS

Life cycle analyses (LCA) are being used increasingly to assess emissions from power projects (among many other infrastructure projects). According to the LCA approach, emissions are assessed for the plant cycle and fuel cycle separately. In the context of geothermal projects, the plant cycle GHG emissions include emissions related to the construction of the power plant and surface installations, drilling and completion of wells, the production of the materials needed for these installations, and the eventual decommissioning of the facilities, normalized over the lifetime of the project. Plant cycle emissions are referred to as upstream and downstream emissions in the World Bank Guidance Manual for GHG accounting (World Bank, 2015). The fuel cycle emissions refer, in the case of geothermal projects, to the release of geothermal GHGs during the energy conversion process. The fuel cycle emissions are sometimes referred to as “operational” or “fugitive” emissions. Most of the available literature on GHG emissions from geothermal projects refers to the fuel cycle emissions only and only a handful of relatively recent publications have addressed the plant cycle emissions from geothermal power production. This is reflected in the discussion below which is largely focused on operational emissions.

### 3.1. ASSESSMENTS OF PLANT CYCLE GHG EMISSIONS FROM GEOTHERMAL PROJECTS

The available information on plant cycle emissions indicate that plant cycle emissions are in the range 2 to almost 20 gCO<sub>2</sub>e/kWh, assuming a project lifetime of 30 years. Sullivan et al. (2013) estimate that the plant cycle emissions for a hypothetical 50 MW flash plant in Southwest United States would be in the range 2 to 5 gCO<sub>2</sub>e/kWh and their estimate for a 10 MW binary plant in the same location was 5 to 6 gCO<sub>2</sub>e/kWh. The numbers are in agreement with the results of Marchand et al. (2015) who estimated plant cycle emissions for three expansion scenarios for the Bouillante geothermal field in Guadeloupe to be in the range from 3.8 to 5.2 gCO<sub>2</sub>e/kWh. Karlsdóttir et al. (2015) estimated that plant cycle emissions from the Hellisheidi plant in Iceland would be of the order of 8.4 to 10.8 gCO<sub>2</sub>e/kWh. The highest value reported for plant cycle emissions is from Hondo (2005) with 15 gCO<sub>2</sub>e/kWh. However, Hondo assumed a capacity factor of only 0.6 for his hypothetical plant. If a more realistic value of 0.9 is used for the capacity factor, then the resulting life cycle emission is 10 gCO<sub>2</sub>e/kWh. Finally, Rule et al. (2009) reported a plant cycle emission value of 5.6 gCO<sub>2</sub>e/kWh for the geothermal power plant in Wairakei, New Zealand. However, this value corresponds to a project lifetime of 100 years. When Rule et al.'s (2009) value is converted to a basis of a 30-year lifetime the resulting plant cycle emission value could be as high as 18.6 gCO<sub>2</sub>e/kWh.

Although the above data are too scarce to derive a statistically significant mean or median value for plant cycle GHG emissions from geothermal power projects, the range of the values estimated in the different studies is relatively small. Considering the range and the magnitude of operational GHG emissions from geothermal projects (see sections 5.2 and 5.3) it is acceptable, for the purpose of this

Interim Technical Note, to assume that plant cycle GHG emissions of geothermal power projects are equal to 10 gCO<sub>2</sub>e/kWh for a standard project lifetime of 30 years. While the data presented by Sullivan et al. (2013) and Marchand et al. (2015) are significantly lower than 10 gCO<sub>2</sub>e/kWh, the difference—amounting to some 5 gCO<sub>2</sub>e/kWh—is insignificant in the context of the overall GHG emissions from geothermal power projects.

### 3.2. GLOBAL AND NATIONAL SURVEYS ON OPERATIONAL GHG EMISSIONS

The most complete global survey on CO<sub>2</sub> emissions to date was presented by Bertani and Thain (2002). Their study was based on emissions and power production information from 85 geothermal power plants in 11 countries, with a combined installed capacity of 6,648 MW, roughly 85 percent of the global geothermal power capacity in operation in 2001. The power plants included in the 2001 global study still amount to more than 50 percent of the total installed capacity today and can be considered a fairly reliable indicator of the range and global average of CO<sub>2</sub> emissions from geothermal power plants. The study found that the range of CO<sub>2</sub> emissions from geothermal power generation was from 4 to 740 g/kWh, and the weighted average was found to be 122 g/kWh. Emissions from binary plants were not included in these numbers (Bertani, personal communication 2014). Also, it should be noted that the survey focused exclusively on CO<sub>2</sub> emissions; CH<sub>4</sub> emissions were not considered. The results of this global survey are presented in a short article in IGA News with very limited details, however, they are supported by CO<sub>2</sub> emission data available from different countries.

Bloomfield et al. (2003) reported an estimate of CO<sub>2</sub> released from power plants in the United States. The reported average emission of CO<sub>2</sub> was found to be 91 g/kWh. Bloomfield et al. (2003) state that non-emitting binary plants amounted to 14 percent of the total capacity of the plants included in their study. The CO<sub>2</sub> emissions from the remaining 86 percent of the plants (i.e., the flashing steam and dry steam plants) can then be computed to be 106 g/kWh.<sup>7</sup> Recent data on CO<sub>2</sub> emissions and power generation of geothermal power plants in California (California Air Resources Board, 2014; US DOE, 2014) allow calculation of CO<sub>2</sub> emission factors for some plants from 2011 to 2013. The results show a fairly wide range of factors. In 2013, the highest CO<sub>2</sub> emission factors were at the three power plants at Coso, ranging from 150 to 300 g/kWh with a weighted average of 245 g/kWh. CO<sub>2</sub> emissions from the Geysers power plants in 2013 were more moderate, ranging from 41 to 76 g/kWh with a weighted average of 45 g/kWh.

Data presented in New Zealand's Sixth Communication to the United Nations Framework Convention on Climate Change and the Kyoto Protocol (2013) allow calculation of CO<sub>2</sub> equivalent emissions from the country's geothermal power plants in 2012 at 122.7 gCO<sub>2</sub>e/kWh. Of these emissions, 104.4 g/kWh are due to CO<sub>2</sub> and the remaining 18.3 gCO<sub>2</sub>e/kWh correspond to CH<sub>4</sub> emissions.

Baldvinsson et al. (2011) presented data for CO<sub>2</sub> emissions from all the Icelandic geothermal power plants from 1970 to 2009 (see Box 2.1). The weighted average CO<sub>2</sub> emissions from the six power plants in 2009 was 50 g/kWh, with a range of 21 to 92 g/kWh. Emission factors have decreased slightly in recent years. According to emission data provided by Icelandic geothermal power producers, in 2013, CO<sub>2</sub> emission factors ranged from 18 to 78 g/kWh and the weighted average was 34 g/kWh.

Again, these numbers represent CO<sub>2</sub> emissions only; CH<sub>4</sub> emissions are not taken into account. Available CH<sub>4</sub> emission data from four out of six geothermal power plants in Iceland suggest that CH<sub>4</sub> emissions could amount to 5 percent of GHG emissions from Icelandic geothermal power plants on a CO<sub>2</sub> equivalent basis.

CO<sub>2</sub> emissions from Italian geothermal plants are generally rather high. Emission factors for power plants in Larderello, Mount Amiata, Val di Cornia and Travale-Chiusino were computed from data from the Regional Environmental Protection Agency for Tuscany (ARPAT, 2012, 2013). Data were available for 2002 to 2013. In this period, the weighted average CO<sub>2</sub> emission factors decreased gradually from 422 to 330 g/kWh. In 2013, CO<sub>2</sub> emission factors ranged from 114 to 827 g/kWh and the weighted average was 330 g/kWh.

### 3.3. HIGH EMISSION OUTLIERS

The highest value for geothermal CO<sub>2</sub> emissions reported by Bertani and Thain (2002) was 740 g/kWh. Bertani and Thain did not report standard deviation of emission factors for the plants observed included in their global survey. However, according to Bertani (personal communication, 2016), the standard deviation of the emission factors was substantial at 163 g/kWh, suggesting that there were already several geothermal power plants with significant GHG emissions in 2002. Since then, new emissions data from several high emission geothermal power plants have become available. Below, two well reported examples in West Turkey and in Mount Amiata, Italy, of high emission geothermal power plants are described. Other high emissions geothermal systems exist, such as the Ngawha system in New Zealand,<sup>8</sup> but there is limited information on the geological and physical conditions in the Ngawha reservoir. What the high CO<sub>2</sub> systems in Turkey and Italy systems seem to have in common is that they are hosted in carbonate-bearing rocks, although anomalous deep mantle CO<sub>2</sub> may also contribute to the high values in Mount Amiata.

#### 3.3.1. Buyuk Menderes Graben, Western Turkey

Aksoy (2014) published CO<sub>2</sub> emission factors for nine power plants in seven geothermal fields in Turkey. The emission factors range from 400 to 1,300 g/kWh and the weighted average (based on installed capacity) is 1,050 g/kWh. Eight of the nine power plants considered by Aksoy (2014) are located in the Menderes graben where most of the feasible geothermal resources for power production in Turkey have been identified (Basel et al., 2010). The range of emissions from the Buyuk Menderes graben power plants is from 900 to 1,300 g/kWh (Aksoy, 2014; Haizlip et al., 2013; Wallace et al, 2009). The second most developed region for geothermal power production in Turkey is the Gediz graben, located north of the Buyuk Menderes graben, and preliminary information indicate that CO<sub>2</sub> emissions will be similar to those from the Buyuk Menderes graben. It should be noted that not all the CO<sub>2</sub> brought to surface by geothermal production in Turkey is released directly into the atmosphere. In at least two of the Turkish geothermal power plants, the CO<sub>2</sub> from the geothermal fluid is captured and sold off as dry ice and liquid CO<sub>2</sub>.

The high gas emissions from the geothermal power plants in Büyük Menderes and Gediz grabens are a result of unusual geological settings. Most of the high temperature geothermal fields in the country are located in the Aegean region in Western Anatolia (Basel, 2010). This area is characterized by extensional tectonics, resulting in graben formations and crustal thinning (Haizlip et al., 2013). High regional heat flow, resulting from crustal thinning appears to be the main source of heat for these geothermal systems (Aksoy et al., 2015; Haizlip et al., 2013). This region is also characterized by an abundance of carbonate sedimentary and metamorphic rocks, such as limestone and marble. The high concentrations of CO<sub>2</sub> in the geothermal fluids in the region seem to result from thermal breakdown of carbonate minerals in the reservoir rocks (Aksoy et al., 2015; Haizlip et al., 2013).

### 3.3.2. Mount Amiata, Italy

The geothermal power plants at Mount Amiata, Italy, provide another example of very high gas emissions. Bravi and Basosi (2014) report CO<sub>2</sub> and CO<sub>2</sub> equivalents emissions from the Bagnore and Piancastagnaio power plants from 2002 to 2009. The range of CO<sub>2</sub> emissions from the two areas was from 245 to 779 g/kWh and the weighted average was 497 g/kWh. The average value for CO<sub>2</sub> equivalent emissions was 693 g/kWh and the range was 380 to 1,045 g/kWh.

Mount Amiata is a Quaternary volcano in southern Tuscany. It is thought that a granitic intrusion related to the volcano is the heat source for the two geothermal fields that occur on the South West and South East flanks of the volcano (Haizlip et al., 2013). Both systems consist of a shallow reservoir with a very gas-rich steam cap and hot (>300°C) deep reservoir. Carbonate rocks are common in the shallow reservoir and exist, to some extent, in the deep the reservoirs of both systems and likely contribute to the high gas concentration in the geothermal fluids (Fron dini et al., 2009; Haizlip et al., 2013). However, δ<sup>13</sup>C isotope data suggest that a significant fraction of the CO<sub>2</sub> in the geothermal reservoirs originates in the mantle (Fron dini et al., 2009). Deep mantle degassing occurs on a regional scale under large parts of Italy (Gambardella et al., 2004).

## ENDNOTES

<sup>7</sup>This study does not report the range of emissions from the United States plants nor the total number of plants and their capacity. It is implied that all geothermal power plants in the United States are included, with a total installed capacity of 2,500 MW at the time (Lund et al., 2005).

<sup>8</sup>The New Zealand Geothermal Association reports an emission factor of 597 g/kWh for the Ngawha power plant (<http://www.nzgeothermal.org.nz/emissions.html>).

# 4

## TECHNICAL OPTIONS TO MITIGATE CO<sub>2</sub> EMISSIONS FROM GEOTHERMAL POWER PLANTS

### 4.1. ENERGY CONVERSION TECHNOLOGIES AND CO<sub>2</sub> EMISSIONS

The four basic types of energy conversion technologies used for geothermal power production are described in Box 4.1. These are back pressure plants, condensing plants,<sup>9</sup> two-phase (flashing) binary plants, and single-phase (pumped) binary plants. Power plants where two or more power cycles are combined are referred to combined cycle power plants.<sup>10</sup> Condensing plants constitute about 84 percent of the worldwide installed capacity of geothermal power plants whereas binary plants amount to 15 percent of the total installed capacity (GEA, 2015). Up to date information on the market share of Single-phase binary plants versus flash binary plants are not available, but as of August 2011, two-thirds of all binary plants were single-phase plants (DiPippo, 2012). Back pressure plants, the most simple but also the most inefficient type of geothermal power plants, amount to only 1 percent of the global installed capacity (GEA, 2015). All of these technologies, with the exception of the single-phase binary, emit effectively all the CO<sub>2</sub> in the produced geothermal fluid to the atmosphere.

The selection of energy conversion process for a particular geothermal project depends on a number of parameters, such as resource temperature, pressure, flow rate, and chemical content. The main difference between processes using steam (back pressure, condensing, two-phase binary) and a liquid (single-phase or pumped binary) is the different driving forces for the flow of the geothermal fluid from the wells to the plant. In the steam processes, the driving force is the pressure difference between the resource and inlet at the power plant. Therefore, no pumping is needed. For single-phase (pumped) binary process, deep well pumps are usually needed.

In single-phase binary plants, the fluid pressure needs to be kept high enough to prevent the formation of a gas phase throughout the process from extraction of the fluid, through the heat exchange process and, eventually, reinjection. This poses two challenges for production from high temperature gas-rich geothermal fluids. Firstly, downhole pumps designed for high temperatures are expensive and their longevity is constrained at high temperatures (Verkís Consulting Engineers, 2015). And secondly, the higher the gas content in the fluid, the higher the pressure that needs to be maintained throughout the system in order to prevent phase separation. Consequently, if emission of gas from gas-rich fluids is to be prevented in pumped binary plants, the pumping may consume a considerable fraction of the power generated.<sup>11</sup> The general resource temperature ranges suitable for the different energy conversion technologies are shown in Table 4.1.

High gas content in geothermal fluid suppresses the boiling point and causes the geothermal fluid to flash at lower temperatures than gas-poor fluid. As a result, in high gas systems, the maximum temperature for pumped binary and the minimum temperature to flashed binary are lowered (see Box 4.1).

The pressure and temperature conditions of the NCG after the energy conversion cycle are different, depending on the energy conversion technology. The NCG exits the heat exchangers of flash binary

### BOX 4.1

#### Energy Conversion Systems and Non-Condensable Gas Emissions

Below is an overview of different conversion technologies and how they affect CO<sub>2</sub> emissions from geothermal power production. Simple process diagrams are used to illustrate the flow of different fluids through the systems with special emphasis on the fate of the NCGs.

##### Back Pressure Turbine

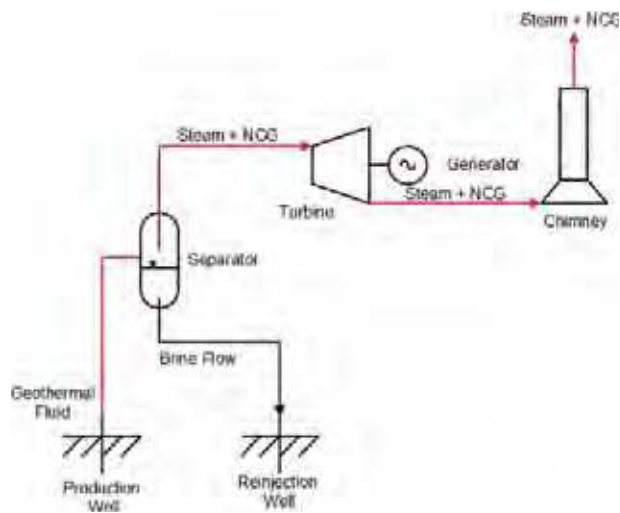

In a back pressure turbine, the geothermal fluid is flashed in a separator, the steam and NCG are admitted to the turbine, and exhausted through the chimney at atmospheric pressure. Back pressure turbines comprise only 1% of the global geothermal power production capacity.

##### Single-Flash Condensing Plant

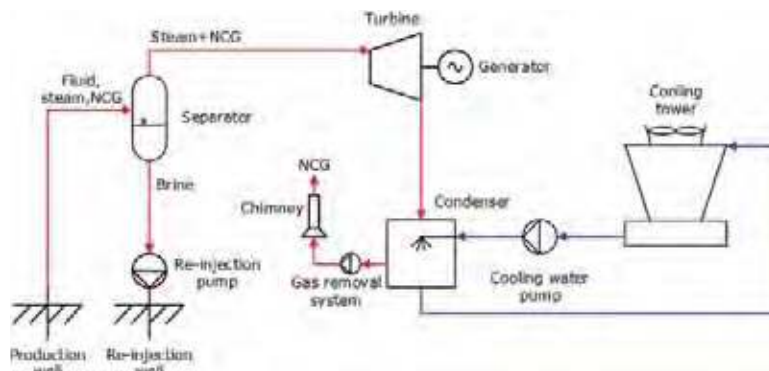

The main difference from the back pressure unit is the addition of a specialized cooling system consisting of a condenser and a cooling tower. This is done to increase the pressure drop over the turbine in order to increase the power output from the turbine and improvement of the overall system efficiency.

(continued)

## BOX 4.1 (CONTINUED)

### Single-Flash Condensing Plant *(continued)*

In a direct cooling condenser, it is necessary to have a specialized gas removal system. The steam and NCGs are cooled directly with a spray of cold water. Most of the steam is condensed there and sinks to the bottom of the condenser as liquid. The NCGs and some of the steam are not condensed. This mixture of low pressure gas and water vapor will have to be removed with a specialized gas removal system to prevent pressure build up in the condenser, which would cause a decrease in the production capacity of the turbine. There are two commonly used types of gas removal devices—ejectors and liquid ring vacuum pumps. The gas is extracted from the condenser and either vented into the atmosphere via the chimney or the cooling tower fan stacks.

A surface (indirect) condenser instead of a direct cooling condenser can also be used. The same principles apply for a surface condenser as a direct condenser; the gas will have to be removed to prevent build-up of NCGs and, then, will be exhausted through a cooling tower or a chimney.

Flash condensing plants can also be double, or even triple, flash. The same applies for these plants as for single flash plants; the NCGs have to be removed through a cooling tower or chimney.

### Two-Phase Binary Power Plant

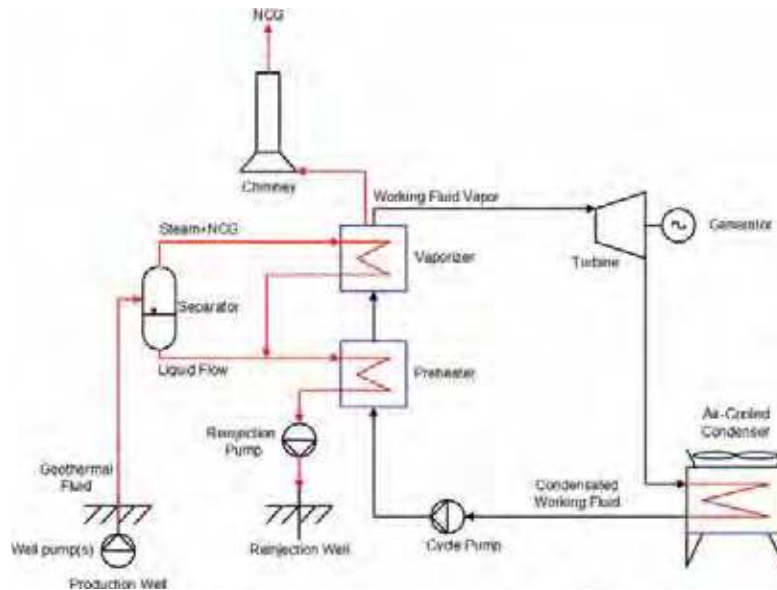

In a two-phase binary power plant, the geothermal fluid is flashed in a separator. The steam and NCGs are used to boil the working fluid in the vaporizer. The design shown involves a preheater where the brine is used to heat the working fluid before it enters the vaporizer. Another common design is to have brine and steam both enter the vaporizer directly but keeping them separated through the process. As the steam passes through the vaporizer, it condenses and the NCGs are vented out of the vaporizer to prevent pressure build-up. The NCG exits the vaporizer at a pressure near the inlet pressure of the steam, commonly 3 to 5 bar-g.

*(continued)*

## BOX 4.1 (CONTINUED)

### Single-Phase (Pumped) Binary Cycle Power Plant

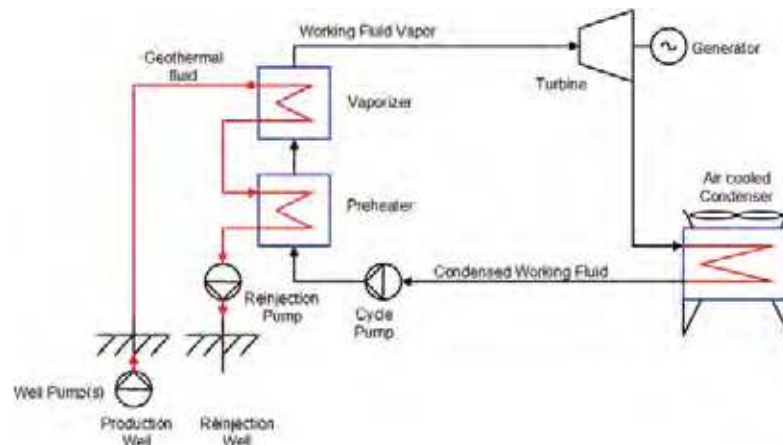

In a typical single-phase binary power plant, the geothermal fluid is kept in liquid phase throughout the entire process. Usually, the geothermal fluid will have to be pumped from the well, but in exceptional cases, the well head pressure is high enough for the well to be self-flowing. To keep the NCGs in the liquid, it is necessary to maintain high pressure through the heat exchanging process. It is also possible to use chemical inhibitors to avoid precipitation of minerals such as calcite that can clog equipment and wells, resulting in additional repair costs. Full reinjection and “zero-emission” is possible for this cycle. If gas emission is to be prevented, the operating pressure needs to be kept high enough to prevent the NCGs from coming out of solution. The NCGs can be vented from the heat exchanger if reinjection is not preferred.

Source | This box draws on materials prepared for this paper by were prepared by Verkis Consulting Engineers, an engineering company.



**TABLE 4.1****Resource Temperature Ranges Suitable for the Different Energy Conversion Technologies**

PLANT TYPE	< 150°C–180°C	180°C–200°C	200°C–220°C	> 220°C
Single-Phase (pumped) Binary	150°C applies if deep pumping is needed			
Two-Phase (flash) Binary				
Combined Cycle (back pressure/binary)				
Flash Condensing				
Back Pressure				

plants at a pressure roughly equal to the inlet pressure of the heat exchanger, typically 3 to 5 bar-g and at a temperature generally below 70°C. The gas exits from combined cycle (back pressure-binary) plants at about the same temperature (<70°C) and about 1 bar-a at temperature. The NCG exits back pressure plants and most condensing plants as steam at atmospheric pressure and near 100°C. As a result, the NCG stream coming from a flash binary plant is better suited for capture and processing as it comes out under pressure and with a much lower content of water vapor compared to the NCG from condensing and back pressure plants (Verkís, 2015).

## 4.2. GAS SEQUESTRATION TECHNOLOGIES

There are several technologies that have been developed to capture and treat NCGs from geothermal power plants. Most of these have been developed to remove H<sub>2</sub>S from the geothermal gas released to the atmosphere but there are also a few examples of geothermal CO<sub>2</sub> capture (Mamrosh et al., 2014). Geothermal CO<sub>2</sub> is captured at some of the geothermal power plants in Turkey, including Kizildere, Dora I and II, and Gumuskoy (c.f. EBRD, 2016). The gas captured at these power plants is commercialized for dry ice production and for production of carbonated beverages (Aksoy, 2014; Simsek et al., 2005). Geothermal CO<sub>2</sub> can also be used to enhance photosynthesis in green houses, production of paint and fertilizer, fuel synthesis, and for enhanced oil recovery (Trimeric Corporation, 2015; Verkís Consulting Engineers, 2015).

It is possible to reinject some or all of the NCG from geothermal plants. This is not widely practiced but two notable example are available. Near complete NCG reinjection is practiced at the Puna plant in Hawaii (Yoram Bronicki, personal communication 2016). Similarly, since 2014, Reykjavik Energy has reinjected about a quarter of the geothermal H<sub>2</sub>S and about 10 percent of the CO<sub>2</sub> from the Hellisheidi Power Plant in Southwest Iceland (Ingvi Gunnarsson, pers. comm., 2016).<sup>12</sup>

The cost and economic feasibility of CO<sub>2</sub> capture from geothermal NCG depends on several factors. These include the NCG composition, the pressure of the NCG at the outlet from the power plant, and the desired purity and pressure of the end product (Mamrosh et al., 2014), as well as the size of the

demand relative to the volume produced. The cost of capturing and processing CO<sub>2</sub> can be estimated from a hypothetical geothermal power plant.<sup>13</sup> Assuming that 1,200 t/day of CO<sub>2</sub> rich NCG is captured, this would correspond to the daily emission from a 50 MW power plant with an emission factor of 1,000 g/kWh or from a 100 MW power plant with an emission factor of 500 g/kWh. Details of this assessment are shown in Box 4.2. The estimated cost of capturing and treating the gas ranged from about \$5/t CO<sub>2</sub> for low pressure gas for green house applications up to about \$23/t CO<sub>2</sub> for liquefied, beverage-

## BOX 4.2

### Estimated Cost of CO<sub>2</sub> Capture and Treatment

The cost of capturing and processing NCG is estimated for a fluid with relatively high CO<sub>2</sub> content (98.4% by volume), moderate concentrations of N<sub>2</sub>, CH<sub>4</sub>, H<sub>2</sub>S, and NH<sub>3</sub> (0.5, 0.7, 0.2 and 0.1% by volume, respectively) and trace concentrations of H<sub>2</sub> and Ar (0.05 and 0.005% by volume, respectively). The assessment considered only commercially available and tested technologies. The total NCG supply was taken to be 50 t/hr. To put this gas supply into perspective, 50 t/hr corresponds to emissions from a 50 MW power plant with an emission factor of 1,000 g/kWh or a 100 MW power plant with an emission factor of 500 g/kWh. Furthermore, it is assumed that the NCG was delivered to the treatment plant saturated with water vapor at 70°C and 4 bar-g. This corresponds to conditions at a two-phase binary plant, which is the most suitable technology when the gas content of the geothermal fluid is high. Treatment of gas from the more conventional condensing power plants will be generally similar to the case considered with two exceptions: (i) O<sub>2</sub> removal will need to be included in the treatment of gas from condensing power plants; and (ii) more compression will be needed as the gas exiting the condenser will be at lower pressure compared to the gas from the binary plants.

The gas treatment cost depends strongly on the intended use of the captured gas. To this end, there are four uses to consider, two of which have more than one treatment option, depending on the presence of trace gases:

- **Low pressure gas for use in greenhouses with or without Hg removal.** The basic case involves the removal of NH<sub>3</sub>, H<sub>2</sub>S, and H<sub>2</sub>O. Bulk removal of NH<sub>3</sub> (to 40 ppmV) is assumed to be achieved by ammonia dissolution in the condensate water. Liquid Redox Sulfur Recovery (LRSR) technology will reduce the H<sub>2</sub>S concentration to less than 1 ppmV and finally, H<sub>2</sub>O is removed from the gas by condensation by cooling the gas to 7.2°C. Additionally, the cost of Hg removal is considered separately as this may not be necessary in many cases. A 5 km pipeline is included in the cost estimate for the greenhouse application.
- **Supercritical CO<sub>2</sub> compressed to 125 bar for Enhanced Oil Recovery.** For this purpose, it is necessary to reduce the concentration of NH<sub>3</sub> to less than 0.1 ppmV in order to prevent the formation of solids during the compression of the gas. This can be achieved by dissolution of NH<sub>3</sub> in condensate water during chilling, followed by acid scrubbing. The same LRSR process for H<sub>2</sub>S removal is anticipated as for the low pressure gas for greenhouse application. H<sub>2</sub>O is removed from the gas through a combination of compression and chilling and glycol dehydration. The pipeline cost is not included in the cost estimate.
- **Liquefied beverage-grade CO<sub>2</sub>** (with and without removal of Hg, COS, and C<sub>2</sub>H<sub>6</sub>). It should be noted that the cost estimate for the liquefied beverage-grade CO<sub>2</sub> also applies to food-grade, dry-ice grade, and industrial-grade CO<sub>2</sub>. The basic case involves the removal of H<sub>2</sub>S, NH<sub>3</sub>, H<sub>2</sub>O, N<sub>2</sub>, Ar, H<sub>2</sub>, and CH<sub>4</sub>. Furthermore, the additional cost of removing the trace gases Hg, COS, and C<sub>2</sub>H<sub>6</sub>, which may or may not need to be removed to meet the standard for beverage-grade CO<sub>2</sub>, is also considered. In this case, NH<sub>3</sub> is

*(continued)*

## BOX 4.2 (CONTINUED)

removed through a combination of compression and chilling and acid washing down to a concentration of less than 0.1 ppmV. The concentration of H<sub>2</sub>S is reduced to less than 0.1 ppmV through a combination of an LRSR process at low pressure and solid scavenger process at 22 bar pressure. H<sub>2</sub>O is removed through condensation and molecular sieves down to concentrations of less than 1 ppm. The more volatile gases (N<sub>2</sub>, Ar, H<sub>2</sub>, and CH<sub>4</sub>) are removed through fractional distillation of the liquefied fluid. The cost of four 500-ton storage tanks for CO<sub>2</sub> is included in the capital cost estimate for the beverage-grade CO<sub>2</sub>. In addition, the cost of removing Hg, COS, and C<sub>2</sub>H<sub>6</sub> is estimated for each gas species.

- Reinjection of NCG along with brine and condensate.** The cost of reinjecting the NCG back into the geothermal reservoir along with a mixture of brine and condensate from the power plant is then estimated. It is estimated that the 50 t/hr of gas would be dissolved in 2,500 t/hr of geothermal liquid at 70°C and 55 bar pressure should be sufficient to dissolve the gas in the liquid at this temperature. This corresponds to about 560 m depth in a well full of water at 70°C or well above the typical depth of geothermal reservoirs (1,000 to 1,500 m). In order to prevent the formation of solids, it is necessary to remove the NH<sub>3</sub> from the gas stream before it is compressed. This is achieved by dissolution in condensate and acid washing as for the supercritical CO<sub>2</sub> for enhanced oil recovery (EOR) and the beverage-grade CO<sub>2</sub>. The gas is then compressed to 55 bar and pumped into a reinjection well along with brine and condensate.

### Cost Assessment of Non-Condensable Gas from Geothermal Power Plants, by Use

PRODUCT	GAS SPECIES REMOVED	CAPITAL COST <sup>1</sup>	POWER USAGE	TOTAL OPERATING COST	CAPITAL AMORTIZATION <sup>1</sup>	TREATMENT COST PER PRODUCT
		\$1,000s	MW	\$1,000/yr	\$1,000/yr	\$/tCO <sub>2</sub>
Greenhouse CO <sub>2</sub>	H <sub>2</sub> S, NH <sub>3</sub> , H <sub>2</sub> O	13,122	0.21	1,364	656	5.00
	Hg	634	0.00	74	31.7	0.25
	Total	13,756	0.21	1,437	688	5.24
CO <sub>2</sub> for EOR	H <sub>2</sub> S, NH <sub>3</sub> , H <sub>2</sub> O	25,304	3.70	4,972	1,265	15.40
	H <sub>2</sub> S, NH <sub>3</sub> , H <sub>2</sub> O, N <sub>2</sub> , H <sub>2</sub> , Ar, CH <sub>4</sub>	37,793	4.60	6,641	1,890	21.10
Beverage-grade CO <sub>2</sub>	Hg	634	0	74	31.7	0.25
	COS	372	0	51	18.6	0.16
	C <sub>2</sub> H <sub>6</sub>	4,230	0.15	421	211.5	1.47
	Total	43,029	4.80	7,187	2121.0	23.00
Reinjection of CO <sub>2</sub>	NH <sub>3</sub>	14,700	3.20	3,443	735	10.30

<sup>1</sup>Includes 20% contingency

Source | Trimeric (2015).

grade CO<sub>2</sub>. Trimeric (2015) estimated that the cost of gas reinjection would be \$10.3/t CO<sub>2</sub><sup>14</sup>. These costs are inclusive of capital cost,<sup>15</sup> operation and maintenance, and power consumption.<sup>16</sup> The power consumption for the GHG applications is modest at 0.2 MW, whereas food-grade purification and subsequent liquefaction will consume about 4.8 MW (Trimeric Corporation, 2015).

The gas capture and treatment costs are highly dependent on site specific conditions, such as the total gas flow (in t/h), the gas to liquid ratio, and the composition of the NCG. The gas composition considered by Trimeric (2015) is representative for high CO<sub>2</sub> geothermal systems where the NCG consists of nearly pure CO<sub>2</sub>. The treatment cost for more typical geothermal NCG compositions, characterized by higher H<sub>2</sub>S/CO<sub>2</sub> ratio, is likely to be higher than the Trimeric estimates. However, NCG capture and treatment may not be relevant for the vast majority of geothermal power plants where GHG emissions are low.

Another important factor to consider in this context is the capacity of the market to absorb geothermal CO<sub>2</sub> products. A study commissioned by EBRD (2016) on the market conditions for geothermal CO<sub>2</sub> in Turkey indicates that the market for beverage-grade CO<sub>2</sub> in Turkey is near saturation with the existing gas capture plants at Kizildere, Dora I, and Gumusköy. Market conditions, thus, may pose more significant constraints on CO<sub>2</sub> capture from geothermal power plants than the technology.

## ENDNOTES

<sup>9</sup>Condensing plants can use either flash steam or dry steam, depending on the nature of the geothermal resource.

<sup>10</sup>Combined cycle plants, where the steam is first passed through a back pressure unit and then to a binary plant, are suitable for gas-rich systems.

<sup>11</sup>Pumping consumes power in all pumped binary geothermal power plants. However, in order to prevent gas release from gas-rich fluids, it may be necessary to operate the power plant at a pressure above the "bubble point" of the fluid (i.e., the pressure at which the gas separates from the water at a given temperature). Raising the operating pressure of the power plant above the bubble point pressure requires additional pumping power.

<sup>12</sup>For a detailed analysis on technical options for CO<sub>2</sub> capture and use and economical and market-related constraints the reader, see the abovementioned report from EBRD (2016).

<sup>13</sup>The estimate is based on calculations prepared for this paper by Trimeric Corporation, a chemical engineering company.

<sup>14</sup>Reinjection cost is highly sensitive to the gas to liquid ratio in the reinjection stream. In gas-rich systems, such as the hypothetical system in the case considered here, relatively high pressure is needed to dissolve the gas in the liquid during reinjection with direct implications for cost due to power consumption and more expensive equipment.

<sup>15</sup>Assuming 20 years amortization.

<sup>16</sup>Assuming a cost of \$0.105/kWh.

## ASSESSING GHG EMISSIONS FROM GEOTHERMAL POWER PROJECTS

This section is intended to supplement the existing Guidance Manual on Greenhouse Gas Accounting for Energy Investment Operations (World Bank, 2015), which outlines the methods used to assess GHG emissions and emission offsets from power projects over the project life time. A fundamental parameter for that assessment is the default GHG emission factor for a given energy source. The Guidance Manual defines the default emission factors based on operational emissions over a project life time. The plant cycle emissions (i.e., upstream and downstream emissions by the Guidance Manual terminology) are defined as scope 3 emissions and their inclusion in the emission estimate for a given project is optional (World Bank, 2015). The objective of this Interim Technical Note is to suggest methodologies to predict or estimate the appropriate GHG emission factors for geothermal power projects at different stages of development. In the subsequent sections, the term “emission factors” is used to refer to operational emissions only.

Figure 5.1 shows the range of GHG emission factors for geothermal power compared to emission factors for power generation using fossil fuels. The figure illustrates that the emission factors from geothermal power plants span a wide range. Although the global weighted average emissions from geothermal power plants—122 g/kWh—is still significantly lower than from fossil fuel plants, in some cases, GHG emissions from geothermal power plant can be high, or up to 1,300 g/kWh in the most extreme case reported. Thus, it is imperative that GHG emissions are assessed in any World Bank-financed geothermal power project.

The accuracy of the estimated GHG emission factors in geothermal power projects will depend significantly on the nature and the quality of the existing information. It is necessary to use the most recent data available and to update the emission estimates as new data become accessible. This applies both to projects that are being developed and to projects already in operation as experience has shown that emission factors from geothermal power plants can change significantly over time. Emission factor estimations should be conservative in order to prevent underestimation on future emissions.

In the following sections, methodologies for assessing GHG emission factors for geothermal projects are presented. (See Box 5.1 for a definition of the phases of geothermal development.) Different approaches need to be taken for this assessment depending on the maturity of the project under consideration. The project maturity levels considered are:

- 1 | **Greenfield projects** - projects that are in the very early stages of development
- 2 | **Brownfield projects** - projects that are in capacity drilling phase or capacity expansion projects in fields where power plants are already operating
- 3 | **Projects involving existing power plants**

**FIGURE 5.1**  
Emission Factors of Geothermal Power Compared to Fossil Fuel

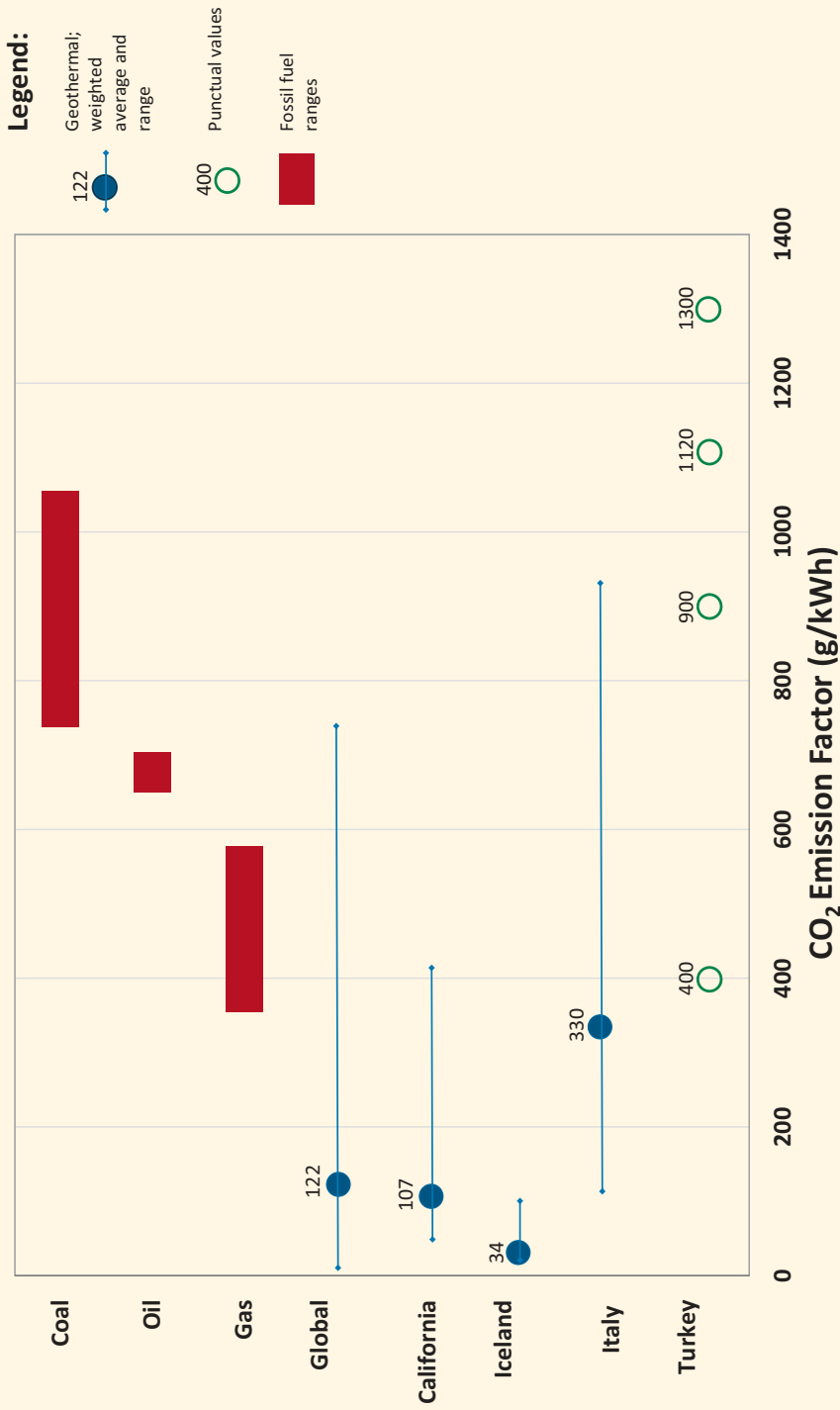

Note | Emission factors for fossil fuels are from World Bank (2015); global geothermal emission factors are from Bertani and Thain (2002); and emission factors for California apply to 2014 and are provided by Ben Metek (per. comm., 2016). The California emission factors are based on emission data for 2014 from California Air Resources Board (CARB) and power generation data from the US Energy Information Administration (EIA). Icelandic geothermal emission factors apply to 2012 and are based on unpublished data from Icelandic geothermal power producers. Italian geothermal emission factors apply to 2013 and were computed from data from ARPAT, and Turkish geothermal emission factors are from Aksoy (2014).

## BOX 5

### Phases of Geothermal Development

The development of a geothermal power project is commonly divided in the four phases summarized below:

- 1 | **Exploration Phase.** This phase establishes the location, size, and quality of the geothermal reservoir; activities conducted include surface exploration, followed by exploration and confirmation drilling.
- 2 | **Resource/Field Development Phase.** This phase includes the drilling of the wells which will be used to mobilize the geothermal resource from the reservoir and confirm the precise volume available for commercial energy production; activities conducted are capacity drilling (also called production drilling).
- 3 | **Power Plant Development Phase.** This phase consists of the final design, procurement, and construction of the power plant that utilizes the geothermal energy identified in Phase II, including steam-gathering systems, power house, and equipment to connect the power plant with the electricity grid.
- 4 | **Facility Operations Phase.** This phase includes the operation and maintenance of the steam-gathering systems and the power plant.

## 5.1. ESTIMATING EMISSION FACTORS FROM GREENFIELD PROJECTS

The term “greenfield geothermal project” refers to projects in the exploration phase in a geothermal systems that is not under production, which includes projects from the initial reconnaissance work until the exploration drilling phase has been completed. As a result, the nature of the information available to estimate the GHG emission factor can differ considerably; from virtually none to observed reservoir temperatures and measured gas concentrations in steam or total fluid from exploration wells. The approach taken to estimate the GHG emission factor for a project will then depend on the nature of the available data. The different approaches are described schematically in Figure 5.2 and further elaborated in the subsequent sections.

### 5.1.1. Greenfield Projects Where No Wells Have Been Drilled

Estimated project emission factors prior to drilling will always be highly uncertain. However, it may be possible to arrive at rough estimates to be used until drilling has provided better insights into the GHG content of the geothermal fluids.

If the geothermal project in question does not have any neighboring projects or if emission data are not available from neighbors, the general geology of the area should be used to guide estimates of emission factors. If there is no available information on the subsurface lithology or if the geological information indicates that the geothermal resource is hosted in volcanic rocks, the most appropriate proxy for the future GHG emission factor is the global average CO<sub>2</sub> emission factor—122 g/kWh. In order to account for potential GHG contribution from CH<sub>4</sub> for projects where the gas composition is not known, it should be assumed that CH<sub>4</sub> constitutes 5 percent of the GHG emission in terms of CO<sub>2</sub> equivalents, resulting in an assumed emission factor of 128 gCO<sub>2</sub>e/kWh.

**FIGURE 5.2**

Approaches to Define GHG Emission Factors from Greenfield Geothermal Projects

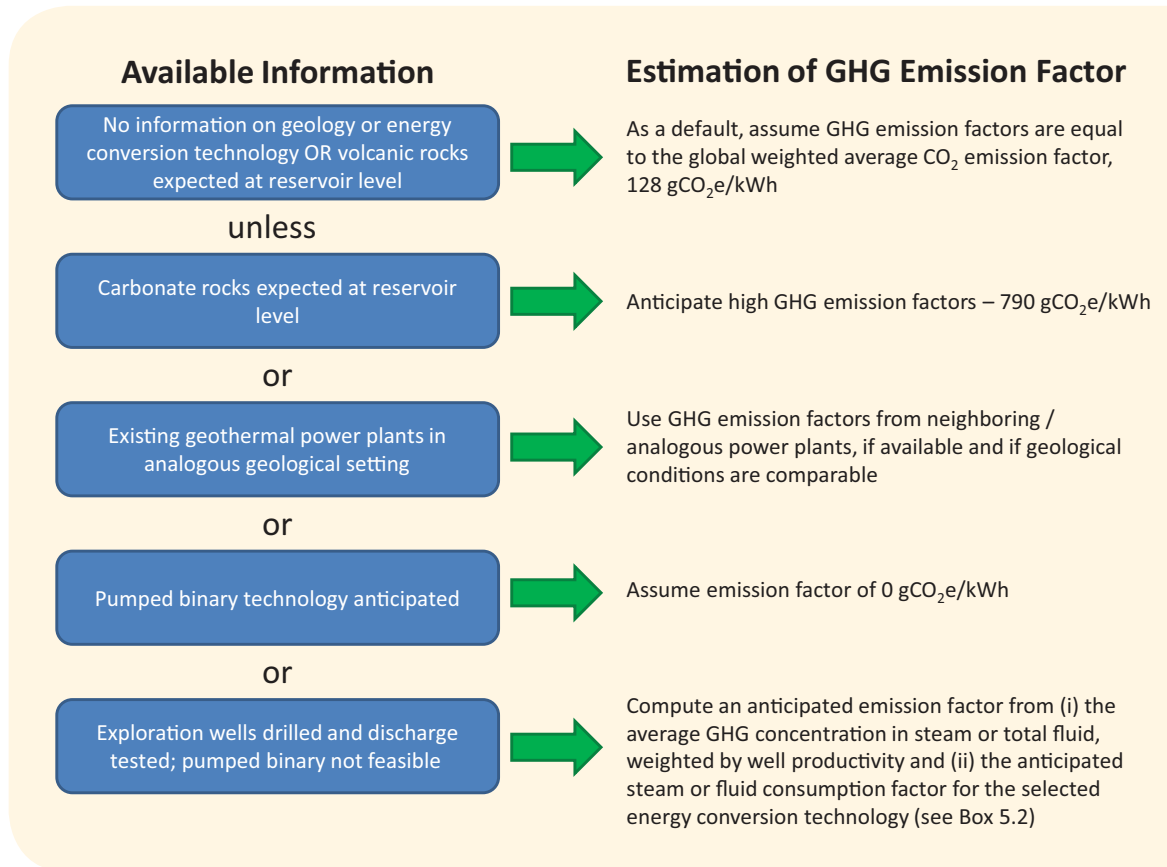

If, however, there is a reason to believe that carbonate rocks are present at reservoir level in a given system, it is appropriate to expect high GHG emission factors for the project. Observed CO<sub>2</sub> emission factors in the Aegean region in Turkey and Mont Amiata in Italy suggest that it would be reasonable to expect CO<sub>2</sub> emissions in the range from 500 to 1,000 g/kWh from projects in carbonate-hosted high temperature systems. It is suggested that in such situations the midrange value, 750 g/kWh, is used (Bertani and Thain, 2002). Again, by assuming a 5 percent contribution from CH<sub>4</sub>, the estimated emission factor will be 790 gCO<sub>2</sub>e/kWh.

If the geothermal project in question is located near existing geothermal power plants or if there is emission information available for power plants in geologically analogous conditions, it may be possible to assume that the emission factors of the existing plants apply to the project being developed. This is justified if the geothermal resource appears to be of similar geological nature as those of the neighboring projects.



Finally, if the available geological information suggest that the geothermal resource in question will be suitable for zero-emission pumped binary technology, an emission factor of 0 g/kWh can be assumed.

### 5.1.2. Greenfield Projects Where Exploration Wells Have Been Drilled and Tested

In projects where exploration wells have been drilled and tested, substantial information should be available for assessing the likely GHG emission factors of a future geothermal power plant. This includes information on the gas concentration in steam or total fluid from the wells and the reservoir temperature. At this stage, it is possible to envisage the most appropriate energy conversion technology for the resource and constrain the steam consumption factor (for back pressure or condensing plants) or fluid consumption factor (for binary plants). Methods for computing predicted GHG emission factors for future power plants from well test data are given in Box 5.2. If zero-emission

#### BOX 5.2

#### Predicting Emissions of Non-Condensable Gases from Geothermal Power Projects from Well Testing Results

Future GHG emission factors for geothermal power projects can be predicted with reasonable confidence when exploration wells have been drilled and tested. A different approach is taken for emissions from two-phase binary plants, on the one hand, and condensing or back pressure plants, on the other. In both cases, it is assumed that the gas content in the fluid from the exploration wells, weighted by well productivity, is representative for production wells to be drilled in the project.

#### Two-Phase Binary Plants

Predicted GHG emission factors ( $EF_{GHG}$  in g/kWh) for two-phase binary plants are computed as:

$$EF_{GHG} = \frac{3600 \left[ \frac{kJ}{kWh} \right]}{h * \eta_{th}} * (C_{CO_2}^{tf} + C_{CH_4}^{tf} * GWP_{CH_4})$$

Where:

$\Delta h$  = Difference between the inlet fluid enthalpy ( $h^i$ ) and the outlet fluid enthalpy ( $h^o$ ) of the plant (in kJ/kg).

The fluid enthalpies are obtained from steam tables for the corresponding temperatures.  $h^i$  is weighted by the productivity of the of the production wells (if more than one).  $h^o$  cannot be lower than the enthalpy of liquid water at annual average ambient temperature at the project site.

$\eta_{th}$  = Thermal net efficiency of the plant (dimensionless). Can range from less than 0.1 to 0.13, depending on design and resource temperature (DiPippo, 2012). If not known, use 0.1.

$C_{CO_2}^{tf}$  = Concentration of  $CO_2$  in the total fluid (g/kg; corresponds to wt%\*10).

$C_{CH_4}^{tf}$  = Concentration of  $CH_4$  in the total fluid (g/kg; corresponds to wt%\*10).

$GWP_{CH_4}$  = Global warming potential of  $CH_4$  valid for the relevant commitment period (t  $CO_2$ e/t  $CH_4$ ). If not known, use 25.

## BOX 5.2 (CONTINUED)

### Condensing Plants and Back Pressure Plants

Predicted GHG emission factors for condensing plants and back pressure plants are computed as:

$$EF_{GHG} = SCF * (C_{CO_2}^{s,P^i} + C_{CH_4}^{s,P^i} * GWP_{CH_4}) * 3.6 \left[ \frac{MWh}{kWh} \right] * \frac{1}{1000} \left[ \frac{g}{mg} \right]$$

Where:

$SCF$  = Steam Consumption Factor (SCF) of the power plant (kg/s/MW). SCF is sensitive to inlet pressure ( $P^i$ ). The SCF for condensing power plants ranges from 2.4 kg/s/MW at 3 bar-a  $P^i$  to 1.8 kg/s/MW at 11 bar-a  $P^i$  (Hudson, 1995). For back pressure plants, the SCF ranges from 5.8 kg/s/MW at 4 bar-a  $P^i$  to 4.2 kg/s/MW at 10 bar-a (Hudson, 2003). Note that back pressure plants will have higher GHG emission factors for the same steam composition than condensing plants due the higher SCF for back pressure plants.

$C_{CO_2}^{s,P^i}$  = Concentration of  $CO_2$  in steam at planned inlet pressure,  $P^i$  (mg/kg). Note that for two-phase wells, the steam composition is sensitive to sampling pressure,  $P^s$ . If  $P^s$  is different from  $P^i$ , the measured  $CO_2$  concentration at  $P^i$  ( $C_{CO_2}^{s,P^i}$ ) is computed as:

$$C_{CO_2}^{s,P^i} = C_{CO_2}^{s,P^s} * \frac{X^{P^s}}{X^{P^i}},$$

where  $X^{P^s}$  and  $X^{P^i}$  represent the steam fraction at  $P^s$  and  $P^i$ , respectively.  $X^{P^s}$  and  $X^{P^i}$  are computed as:

$$X^{P^s} = \frac{h^{td} - h^{l,P^s}}{h^{v,P^s} - h^{l,P^s}} \text{ and } X^{P^i} = \frac{h^{td} - h^{l,P^i}}{h^{v,P^i} - h^{l,P^i}},$$

where  $h^{td}$  is the enthalpy of the total discharge (kJ/kg) and  $h^v$  and  $h^l$  are the enthalpy of vapor and liquid (kJ/kg), respectively at the superscripted pressure.

$C_{CH_4}^{s,P^i}$  = Concentration of  $CH_4$  in steam at inlet pressure,  $P^i$  (mg/kg).

$GWP_{CH_4}$  = Global warming potential of  $CH_4$  valid for the relevant commitment period (t  $CO_2e$ /t  $CH_4$ ). If not known, use 25.

pumped binary technology is the selected energy conversion technology at this stage, the future emissions can be taken to be zero.

## 5.2. ESTIMATING EMISSION FACTORS FOR BROWNFIELD PROJECTS

The term “brownfield geothermal project” refers to projects that are in capacity drilling or capacity expansion phases in fields where power plants are already operating. In the case of new projects at the capacity drilling phase, the GHG emission factors can be predicted based on well testing data as explained in Box 4.2. GHG emission factors for expansion projects shall be taken to be equal to

the emission factors for the existing power plant(s), unless there is a well understood reason for not doing so. This applies if a project expansion is based on wells targeting a part of the reservoir with different gas content than the production wells of the existing plants. One example of this could be an expansion project intended to produce from a gas-rich steam cap while existing wells produce from a liquid-dominated deep reservoir. In such a case, the estimated emission factor should be based on the well testing data collected from existing production wells drilled in the exploration and capacity drilling phases of the project (see Box 4.2).

### 5.3. CONSTRAINING EMISSION FACTORS FOR EXISTING PROJECTS

The Clean Development Mechanism (CDM) methodology for reporting GHG emissions from geothermal projects, including fugitive emissions of CO<sub>2</sub> and CH<sub>4</sub>, is outlined in Box 5.3. This methodology is developed for steam power plants (i.e., condensing and back pressure plants). However, it can be easily applied to assess emissions from two-phase binary plants by replacing the word “steam” with “fluid.” The CDM methodology should be followed when determining GHG emissions of geothermal plants.

The CDM methodology has no provision for addressing gas capture. However, when NCGs are captured and used either for industrial or agricultural applications or reinjected back into the reservoir, the amount of gas captured on an annual basis should be subtracted from the annual fugitive emissions outlined in Box 5.2.

Emission factors from geothermal power plants may change over time but it is difficult to predict with any certainty whether they will increase, decrease, or remain constant. The conservative approach is to assume that emission factors remain constant when projecting future emissions. These predictions should then be revised when actual measurements of gas emissions are collected following the CDM methodology (see Box 5.3).

### 5.4. ESTIMATING PLANT CYCLE EMISSION FACTORS FOR GEOTHERMAL POWER PROJECTS

As noted earlier, plant cycle emissions are considered scope 3 emissions under the World Bank GHG accounting scheme (World Bank, 2015) and the inclusion of such emissions in the GHG accounting for energy investment operations is optional. Comparison of the available estimates of plant cycle emissions for geothermal power projects (see section 5.1) to operational emissions (sections 5.2 and 5.3) illustrate that the plant cycle emissions are generally small compared to operational emissions. Excluding plant cycle emissions from GHG accounting for geothermal power projects, thus, will not result in significant underestimation of the projects' total emissions.

If plant cycle emissions (upstream and downstream emissions) are to be included in GHG accounting for a given geothermal power project, a value of 10 g/kWh should be used for a project lifetime of 30 years. This value—a conservative estimate—is close to the higher end of the estimates available in the literature.

### BOX 5.3

#### CDM Methodology for Calculation of Project Emissions from Geothermal<sup>1</sup>

The calculation of emissions from geothermal projects must take into account two sources of GHGs:

- 1 | **Emissions from fossil fuel combustion.** CO<sub>2</sub> emissions from the use of fossil fuels for electricity generation. To be calculated as per the latest version of the “Tool to calculate project or leakage CO<sub>2</sub> emissions from fossil fuel combustion” (available at: <https://cdm.unfccc.int/methodologies/PAMethodologies/tools/am-tool-03-v2.pdf>).
- 2 | **Emissions of NCGs from the operation of the geothermal power plant.** Fugitive emissions of CO<sub>2</sub> and CH<sub>4</sub> due to the release of NCGs from produced steam. As a conservative approach, the methodology assumes that all NCGs entering the power plant are discharged to the atmosphere via the cooling tower. Fugitive CO<sub>2</sub> and CH<sub>4</sub> emissions due to well testing and well bleeding are not considered, as they are considered negligible.

The formula to calculate these fugitive emissions is:

$$PE_{GP,y} = (w_{steam,CO_2,y} + w_{steam,CH_4,y} \times GWP_{CH_4}) \times M_{steam,y}$$

Where:

$PE_{GP,y}$  = Project emissions from the operation of geothermal power plants due to the release of NCGs in year  $y$  (t CO<sub>2</sub>e/yr)

$w_{steam,CO_2,y}$  = Average mass fraction of CO<sub>2</sub> in the produced steam in year  $y$  (t CO<sub>2</sub>/t steam)

$w_{steam,CH_4,y}$  = Average mass fraction of CH<sub>4</sub> in the produced steam in year  $y$  (t CH<sub>4</sub>/t steam)

$GWP_{CH_4}$  = Global warming potential of CH<sub>4</sub> valid for the relevant commitment period (t CO<sub>2</sub>e/t CH<sub>4</sub>). If not known, use 25.

$M_{steam,y}$  = Quantity of steam produced in year  $y$  (t steam/yr)

The average mass fraction of CO<sub>2</sub> and CH<sub>4</sub> must be determined by sampling NCGs in production wells and/or at the steam field-power plant interface, using *ASTM Standard Practice E1675* for sampling two-phase geothermal fluid for purposes of chemical analysis, at least once every three months.



## ADDRESSING KNOWLEDGE GAPS THROUGH INVESTMENT PROJECTS

There are significant uncertainties regarding many aspects of GHG emissions from geothermal power plants as discussed in Part I. Some of these data gaps could be closed, at least to some degree, by systematic data collection in new and existing geothermal projects. Three specific areas where the World Bank and other financial institutions could effectively improve the state of the knowledge of the geothermal community on GHG emissions from geothermal projects are:

- 1 | The nature and magnitude of long-term changes in GHG emissions from geothermal power plants over time
- 2 | The effect of geothermal power production on CO<sub>2</sub> emissions through the surface in geothermal fields
- 3 | Cost of capture and treatment of GHG from geothermal power plants for industrial or agricultural uses

### 6.1. LONG-TERM CHANGES IN GHG EMISSIONS FROM POWER PLANTS

As discussed above, there is anecdotal evidence of a gradual decrease in CO<sub>2</sub> emissions from geothermal power plants over time. This effect has been attributed to the return of gas-free reinjection fluid to the reservoir, which dilutes the concentration of dissolved gases in the reservoir fluid and gradual degassing of the reservoir liquid due to progressive boiling. Publicly available data illustrating this process are scarce and of varying quality. Furthermore, it is impossible to ascertain whether the available data are representative for geothermal systems in general or if they are selected for publication because they show this specific effect. The magnitude of this effect in existing geothermal power plants, thus, is poorly known and the existing body of data does not allow prediction of future trends for new developments.

Systematic collection of gas emission data from geothermal projects financed by the World Bank, other multilateral development banks, and project financiers would help to rapidly build up a data set that could provide a more precise picture of the evolution of GHG emissions from geothermal plants over time. Such a data set may not allow accurate prediction of future trends in undeveloped systems, but an expected range of potential GHG emissions variations could be established. Financiers and developers should agree to obtain data on GHG emissions from plants being developed. Such agreements could include a confidentiality clause whereby the keeper of the database would commit to releasing the data only in aggregate, or otherwise untraceable to specific projects, after a given period of time. This data would need to be centralized at the country level and made publicly available by the relevant government entity.

Systematic collection of GHG emission data from geothermal projects would not impose additional costs on the project operators. Gas content in the steam and total fluid are already carefully

monitored in modern geothermal power plants as the gas content is an important parameter for the operation of the plants. It would just be a matter of collecting the information in a central repository for further analysis.

## 6.2. EFFECTS OF PRODUCTION ON GHG EMISSIONS THROUGH SOIL AND FUMARoles

As explained before, geothermal power production may impact surface activity. This may lead to increasing emissions of geothermal gases through the surface in addition to what is emitted by the power plant, as in Reykjanes, Iceland, and has likely happened at Wairakei and Ohaaki, New Zealand, as well. On the other hand, observations from Larderello and Mount Amiata, Italy, indicate that power production from these systems has resulted in decreasing surface activity.

The data currently available to assess the effect of power production on natural emissions through the surface, at present, do not allow general predictions to be made, neither on the magnitude of the effect of production nor on whether the gas emissions will tend to increase or decrease. In order to accelerate the understanding of these effects, it is necessary to carry out soil gas surveys in different geothermal fields in a variety of geological settings. The World Bank could contribute to this by funding baseline CO<sub>2</sub> soil emission studies in World Bank-financed geothermal projects, when possible. Subsequent monitoring studies after power plant commissioning will garner understanding of this phenomenon within the scientific community and may eventually lead to consideration of these effects when project emissions are evaluated.

## 6.3. COST OF GHG CAPTURE AND TREATMENT

There are examples of economically viable capture of geothermal CO<sub>2</sub> for industrial and agricultural purposes (e.g., from the Menderes graben in Turkey) and reinjection of captured geothermal gas is a topic of research and development. However, capture and treatment of geothermal CO<sub>2</sub> is currently uncommon worldwide. This may be due, in part, to limited awareness of geothermal developers of the potential economic benefits of capturing geothermal gas for commercial purposes; the limited understanding of the capital and operational costs involved may also be a limiting factor. The cost estimates presented in Box 4.2 are general prefeasibility numbers that apply to market conditions in the United States and may give some guidance for preliminary feasibility evaluation. However, complete feasibility studies based on site-specific conditions, such as gas supply and gas composition, and local market circumstances, are necessary for a firm analysis of the economic viability of such investments.

The World Bank and other multilateral development banks could play an active role in catalyzing the use of GHG capture technologies in geothermal power projects. The fact is that costs of the GHG capture and treatment options are often unassessed due to their small potential benefits. Understanding those costs and their benefits better could be done by encouraging users of World Bank support to prepare a feasibility analysis of GHG capture for geothermal projects with significant GHG emissions, limited to projects with expected emission factors above the national grid emission

factor or above 250 g/kWh (roughly double the global average emission factor for geothermal plants), whichever is higher. If GHG capture and treatment is found to be economically feasible for a particular project, World Bank financing could be provided for the necessary capture investments.

The advantages of this approach are twofold. First, this will encourage investment in GHG capture where found to be economically feasible and, secondly, this will improve the available information on the costs of installing and operating these technologies. Increased use of these technologies and improved information on the cost would raise awareness among other project developers about the economic benefits of GHG capture from geothermal power plants.





## REFERENCES

- Allis. 1981. "Changes in heat flow associated with exploitation of the Wairakei geothermal field, New Zealand." *NZ Journal of Geology and Geophysics*, 24: 1–19.
- Aksoy, N. 2014. "Power generation from geothermal resources in Turkey." *Renewable Energy*, 68: 595–601.
- Ármannsson, H., Fridriksson, Th., and Kristjánsson B. R. 2005. "CO<sub>2</sub> emissions from geothermal power plants and natural geothermal activity in Iceland." *Geothermics*, 34: 286–296.
- Ármannsson, H., Fridriksson, Th., Benjaminsson, J., and Hauksson, T. 2015. "History of chemical composition of geothermal fluids in Krafla, northeast Iceland, with special emphasis on the liquid phase." Proceedings of the World Geothermal Congress, New Zealand, Australia.
- Arnórsson, S. 1995. "Geothermal systems in Iceland: Structure and conceptual models in high temperature areas." *Geothermics*, 24: 561–602.
- Arnórsson S., Stefánsson, A., and Bjarnason, J. Ö. 2007. "Fluid-Fluid Interactions in Geothermal Systems." *Reviews in Mineralogy and Geochemistry*, 65: 259–312.
- ARPAT [Regional Environmental Protection Agency for Tuscany]. 2014. Monitoring of geothermal areas in Tuscany in 2013, Control of emissions from geothermal plants, Geothermal Sector, Vasta Sud Area.
- ARPAT. 2013. Monitoring of geothermal areas in Tuscany in 2012. Control of emissions from geothermal plants & Air quality monitoring of the geothermic areas of Tuscany, Geothermal Sector, Vasta Sud Area.
- Baldvinsson, Í., Thórisdóttir, Th., and Ketilsson, J. 2011. Gas emissions from geothermal power plants in Iceland 1970 to 2009. National Energy Authority, OS-2011/02: 33.
- Basel E. D. K., Serpen, U., and Satman, A. 2010. "Turkey's geothermal energy potential: Updated results." Proceedings Thirty-Fifth Workshop on Geothermal Reservoir Engineering, Stanford University.
- Barelli, A., Ceccarelli, A., Dini, I., Fiorelisi, A. Giorgi, N, Lovari, F., and Romagnoli, P. 2010. "A review of the Mt. Amiata geothermal system (Italy)." Proceedings of the World Geothermal Congress, Bali, Indonesia.
- Beall, J., Wright, M. C., and Hulen, J. B. 2007. "Pre- and Post-Development Influences on Fieldwide Geysers NCG Concentrations." *Geothermal Resources Council Transactions*, 31: 427–434.
- Benoit, D. and Hirtz, P. 1994. "Non-Condensable Gas Trends and Emissions at Dixie Valley, Nevada." *Geothermal Resources Council Transactions*, 18: 113–119.
- Bertani, R., and Thain, I. 2002. "Geothermal power generating plant CO<sub>2</sub> emission survey." *IGA News*, 49: 1–3.
- Bjarnason, J. Ö. 1996. Svartsengi: Geochemical monitoring 1988–1995. National Energy Authority, OS-96082/JHD-10.
- Bloomfield, K. K., Moore, J. N., and Neilson, R. N. 2003. "Geothermal energy reduces greenhouse gases." *Geothermal Resources Council Bulletin*, 32: 77–79.
- Bravi M. and Basosi R. 2014. "Environmental impact of electricity from selected geothermal power plants in Italy." *Journal of Cleaner Production*, 66: 301–308.
- CARB [California Air Resources Board]. 2014. California Environmental Protection Agency, Annual Summary of GHG Mandatory Reporting, Non-Confidential Data for Calendar Year 2008–2013. Accessed December 2014: <http://www.arb.ca.gov/cc/reporting/ghg-rep/reported-data/ghg-reports.htm>.
- EBRD [European Bank for Reconstruction and Development]. 2016. *Assessing the use of CO<sub>2</sub> from natural sources for commercial purposes in Turkey*.
- ESMAP [Energy Sector Management Assistance Program]. 2012. *Geothermal Handbook: Planning and Financing Power Generation*. ESMAP Technical Report 002/12. Washington DC: World Bank.

- Fridriksson, Th., Óladóttir, A.A., Jónsson, P., and Eyjólfsdóttir E. I. 2010. "The Response of the Reykjanes Geothermal System to 100 MWe Power Production: Fluid Chemistry and Surface Activity." Proceedings of the World Geothermal Congress, Bali, Indonesia.
- Fridriksson, Th., Padrón, E., Óskarsson, F., and Pérez, N.M., 2015. "Application of diffuse gas flux measurements and soil gas analysis to geothermal exploration and environmental monitoring: Example from the Reykjanes geothermal field, SW Iceland." *Renewable Energy*, 86: 1295–1307.
- Fron dini, F., Caliro, S., Cardellini, C., Chiodini, G., and Morgantini, N. 2009. "Carbon dioxide degassing and thermal energy release in the Monte Amiata volcanic-geothermal area (Italy)." *Applied Geochemistry*, 24: 860–875.
- Gambardella, B., Cardinelli, C., Chiodini, G., Fron dini, G., Marini, L., Ottonello, G., and Zuccolini, M.V. 2004. "Fluxes of deep CO<sub>2</sub> in the volcanic areas in central-southern Italy." *Journal of Volcanology and Geothermal Research*, 136: 31–52.
- GEA [Geothermal Energy Association]. 2015. 2015 Annual U.S. & Global Geothermal Power Production Report. Accessed in January 2016: <http://geo-energy.org/reports/2015/2015%20Annual%20US%20%20Global%20Geothermal%20Power%20Production%20Report%20Draft%20final.pdf>.
- Glover, R. B., Mroczek, E. K., and Finlayson, J. B. 2001. "Fumarolic gas chemistry at Wairakei, New Zealand, 1936–1998." *Geothermics*, 30: 511–525.
- Glover, R. B. and Mroczek, E. K. 2009. "Chemical changes in natural features and well discharges in response to production at Wairakei, New Zealand." *Geothermics*, 38: 117–133.
- Glover, R. B. and Scott, T.M. 2005. "Geochemical Monitoring Before and During Six Years of Power Generation at Ngawha, New Zealand." Proceedings of the World Geothermal Congress, Antalya, Turkey.
- Haizlip, J. R., Haklidir, F. T., and Garg, S. K. 2013. "Comparison of reservoir conditions in high non-condensable gas geothermal systems." Proceedings, Thirty-Eighth Workshop on Geothermal Reservoir Engineering, Stanford University.
- Hondo, H. 2005. "Life cycle GHG emission analysis of power generation systems: Japanese case." *Energy*, 30: 2042–2056.
- Hudson, R. B. 2003. "Electricity Generation." In Dickson, M. H. and Gianelli, M., eds., *Geothermal Energy: Utilization and Technology*, pp. 29–51. Paris: UNESCO.
- Karlsdóttir, M. R., Pálsson, Ó. P., and Pálsson, H. 2010. "Factors for Primary Energy Efficiency and CO<sub>2</sub> Emission of Geothermal Power Production." Proceedings of the World Geothermal Congress, Bali, Indonesia.
- Kaya, E., Zarrouk, S. J., and O'Sullivan, M. J. 2011. "Reinjection in geothermal fields: A review of worldwide experience." *Renewable and Sustainable Energy Reviews*, 15: 47–68.
- Klein, C. W., Eney, S., Butler, S. J., and Morrow, J. W. 2009. "Injection Returns and Evolution of Non-Condensable Gases at the NCPA Geysers Wellfield, California." *Geothermal Resources Council Transactions*, 33: 1053–1059.
- Lund, J. W., Bloomquist, R. G., Boyd, T. L., and Renner J. 2005. "The United States of America Country Update." Proceedings of the World Geothermal Congress, Antalya, Turkey.
- Mamros h D. L., McIntush, K. E., Douglas, A., Fisher K. S., Júlíusson, B. M., Gunnarsson, I., Markússon, S. H., Matthíasdóttir, K. V., and Arnarson, M. Th. 2014. "Removal of Hydrogen Sulfide and Recovery of Carbon Dioxide from Geothermal Non-Condensable Gas Using Water." *Geothermal Resources Council Transactions*, 38: 673–679.
- Marchand, M., Blanc, I., Marquand, A., Beylot, A., Bezelgues-Courtarde, S., and Traineau, H. 2015. Life Cycle Assessment of High Temperature Energy Systems. Proceedings of the World Geothermal Congress, Melbourne, Australia.
- New Zealand Ministry for Environment. 2013. New Zealand's Sixth National Communication under the United Nations Framework Convention on Climate Change and the Kyoto Protocol.
- Óladóttir, A. A. and Fridriksson, Th. 2015. "The Evolution of CO<sub>2</sub> Emissions and Heat Flow through Soil since 2004 in the Utilized Reykjanes Geothermal Area, SW Iceland: Ten Years of Observations on Changes in Geothermal Surface Activity." Proceedings of the World Geothermal Congress, Melbourne, Australia.

- Óskarsson, F. 2014. Svartsengi production field: Geochemical monitoring in 2013. Iceland GeoSurvey, ÍSOR 2014/012.
- Rissmann, C., Christenson, B., Werner, C., Leybourne, M., Cole, J., and Gravley, D. 2012. "Surface heat flow and CO<sub>2</sub> emissions within the Ohaaki hydrothermal field, Taupo Volcanic Zone, New Zealand." *Applied Geochemistry*, 27: 223–239.
- Rule, B. M., Worth, Z. J., and Boyle, C. A. 2009. "Comparison of life cycle carbon dioxide emissions and embodied energy in four renewable electricity generation technologies in New Zealand." *Environmental Science and Technology*, 43: 6406–6413.
- Sammarco, G. and Sammarco, O. 2002. "Gas from thermal waters: Release pathways, risks and precautions." *Acque Sotteranee*, 78: 35–46 (in Italian).
- Simsek, S., Mertoglu, O., Bakir, N., Akkus, I., and Aydogdu, O. 2005. "Geothermal Energy Utilization, Development and Projections—Country Update Report (2000–2004) of Turkey." Proceedings of the World Geothermal Congress, Antalya, Turkey.
- Stefánsson, V. 1997. "Geothermal reinjection experience." *Geothermics*, 46: 99–139.
- Sullivan, J. L., Clark, C., Han, J., Harto, C., and Wang, M. 2013. "Cumulative energy, emission, and water consumption for geothermal electric power production." *Journal of Renewable and Sustainable Energy*, 5.
- US DoE [U.S. Department of Energy]. The Energy Information Administration (EIA), Electric Power Generation and Fuel Consumption, 2008–2013, Form EIA-923, Power Plant Operations Report. Accessed in December 2014: <http://www.eia.gov/totalenergy/data/annual>.
- Trimeric Corporation. 2015. Early-Phase Evaluation of CO<sub>2</sub> Recovery at Geothermal Facilities. Final Report. Prepared for ESMAP. Washington DC: The World Bank.
- Verkís Consulting Engineers. 2015. Geothermal Power Plants—CO<sub>2</sub> Emissions. Verkís Report 14298-001-1.
- Wallace, K., Dunford, T., Ralph, M., and Harvey, W. 2009. "Germencik: A Thoroughly Modern Flash Plant in Turkey." *Geothermal Resources Council Transactions*, 33: 759–764.
- World Bank. 2015. *Guidance Manual: Greenhouse Gas Accounting for Energy Investment Operations. Transmission and Distribution Projects, Power Generation Projects, and Energy-Efficiency Projects* (ver. 2.0). Washington, DC: The World Bank.





**ENERGY SECTOR MANAGEMENT ASSISTANCE PROGRAM**  
**THE WORLD BANK**  
**1818 H STREET, NW**  
**WASHINGTON, DC 20433 USA**  
**EMAIL: [ESMAP@WORLDBANK.ORG](mailto:ESMAP@WORLDBANK.ORG)**  
**WEB: [WWW.ESMAP.ORG](http://WWW.ESMAP.ORG)**

**PHOTOGRAPHY CREDITS**

**COVER: ©MRLOZ; MISSION: ©RAMONA GEORGESCU;**  
**TABLE OF CONTENTS: ©SHAIITH; PAGE 40: ©STRANNIK;**  
**PAGE 44: ©NATMINT. ALL VIA THINKSTOCK.COM.**

**PRODUCTION CREDITS**

**PRODUCTION EDITOR | HEATHER AUSTIN**  
**DESIGN | CIRCLE GRAPHICS, INC.**