

# Guidelines of Business Process Modeling

Jörg Becker<sup>1</sup>, Michael Rosemann<sup>2</sup>, Christoph von Uthmann<sup>1</sup>

<sup>1</sup> Westfälische Wilhelms-Universität Münster

Department of Information Systems

Steinfurter Str. 109, 48149 Münster, Germany

Phone: +49 (0)251/83-38100, Fax: +49 (0)251/83-38109

{isjobe|ischut}@wi.uni-muenster.de

<sup>2</sup> Queensland University of Technology

School of Information Systems

2 George Street, Brisbane QLD 4001, Australia

Phone: +61 (0)7 3864 1117, Fax: +61 (0)7 3864 1969

m.rosemann@qut.edu.au

**Abstract.** Process modeling becomes more and more an important task not only for the purpose of software engineering, but also for many other purposes besides the development of software. Therefore it is necessary to evaluate the quality of process models from different viewpoints. This is even more important as the increasing number of different end users, different purposes and the availability of different modeling techniques and modeling tools leads to a higher complexity of information models. In this paper the Guidelines of Modeling (GoM)<sup>1</sup>, a framework to structure factors for the evaluation of process models, is presented. Exemplary, Guidelines of Modeling for workflow management and simulation are presented. Moreover, six general techniques for adjusting models to the perspectives of different types of user and purposes will be explained.

## 1 Complexity and Quality of Business Process Models

The popularity of different process management approaches like Lean Management [58], Activity-based Costing [52], Total Quality Management [21, 35], Business Process Reengineering [16, 17], Process Innovation [7, 8], Workflow Management [14], and Supply Chain Management [39] has two main effects concerning the requirements on process models. First, the number and variety of model designers and users has spread enormously. Especially, representatives from various business and technical departments, who are not necessarily modeling experts are increasingly involved in the design of process models. As a consequence, the understandability of process models is of growing importance. Secondly, the number and variety of

---

<sup>1</sup> This paper presents results from the research project Guidelines of Modeling (GoM), which was funded by the German Ministry of Education, Science, Research, and Technology, project no.: 01 IS 604 A.

purposes process models are used for is growing. Besides the "traditional" use of process models within software engineering these models are more and more used for pure organizational purposes like process reorganization, certification, Activity-based Costing or human resource planing (see as well [37]).

Process modeling is supposed to be an instrument for coping with the complexity of process planning and control. Existing models show as well considerable complexity themselves, though. Hence, the *design* of process models often turns out to be very problematic. It has direct influence on the economic efficiency of the underlying process-related project. In the first place the model design requires personnel resources and (if necessary) the purchase of software tools. Moreover, the risk exists that the process models, referring to their purpose, are not sufficient. For example, semantic mistakes or the disregarding of relevant aspects can lead to possibly expensive misjudgments. Consequently, the design of models always is an economical risk and not only a modeling exercise.

Especially in enterprise-wide process management projects the design of integrated process models can become a comprehensive challenge. The number of process models can easily be higher 500 with five or more different levels. The related risk will be increased if the model design is seen as a domain of "modeling specialists" who are supposed to be the only ones who understand "their" models. In contrast to this, a business process model should serve as a communication base for *all* persons involved. Consequently, the quality of process models can beyond the fulfillment of syntactic rules defined as its "fitness for use".

Within this context a framework called *Guidelines of Modeling (GoM)* has been developed to assure the quality of information models beyond the accordance to syntactic rules. The GoM-framework includes six guidelines, which aim to improve the quality of information models (product quality) as well as the quality of information modeling (process quality). The *design of business process models* is one core field within the project.

This paper describes first the general intention and the framework of the Guidelines of Modeling (section 2). Exemplary, Guidelines of Modeling for workflow management and simulation, two main purposes of process modeling, are discussed in the third section. Section 4 presents six different techniques for the adaptation of models to perspectives of different users and purposes. The paper ends with a brief conclusion.

## 2 The Guidelines of Modeling (GoM)

Various frameworks for quality assurance of information models were already presented. Usually, they are either focussing only one kind of information models, in particular data models (like the approaches from [1] or [31, 32]), they focus only special requirements [2, 59], or they contain such high-level-statements, that it is difficult to derive useful recommendations for modeling projects [24, 27].

The aim of the Guidelines of Modeling (GoM) is the development of specific design recommendations in order to increase the quality of models beyond the

fulfillment of syntactic rules [3, 41, 42]. The term GoM has been chosen as an analogy to the Generally Accepted Accounting Principles (GAAP) [9, 29, 38]. On the one hand, the GoM result from the selection of the relevant aspects for information modeling from the GAAP.

On the other hand, the GoM adapt elements of the existing approaches for the evaluation of information models. The Guidelines of Modeling, which are presented here (see for an alternative suggestion [49]), contain six guidelines to ameliorate the quality of information models. These are the principles of correctness, relevance, economic efficiency, clarity, comparability, and systematic design (figure 1, see also [31]). While the observance of the principles of correctness, relevance and economic efficiency are a necessary precondition for the quality of models, the principles of clarity, comparability and systematic design have a mere optional character.

The GoM-framework includes besides the six *general guidelines* (level 1) recommendations for different *views* (level 2, e.g. process models) and for different *modeling techniques* (level 3, e.g. Event-driven Process Chains (EPC) or Petri Nets).

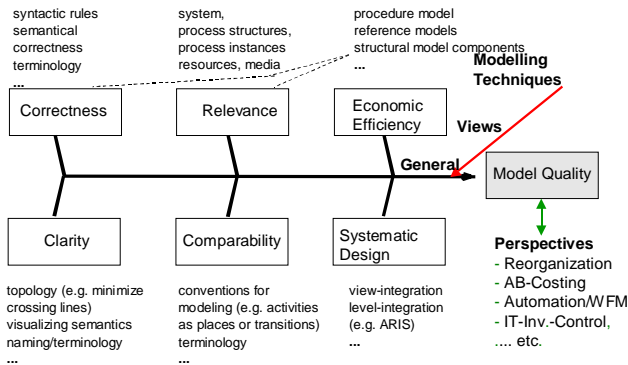

**Fig. 1.** The Framework of the Guidelines of Modeling (GoM)

## 2.1 The Basic Guidelines

The basic guidelines consist of the guideline of correctness, the guideline of relevance, and the guideline of economic efficiency.

The *guideline of correctness* has got two facets [1]: the syntactic and the semantic correctness. A model is syntactic correct, if it is consistent and complete against the meta model (see for definitions of meta model ([33], p. 38, [44], pp. 104-105) the model is based on. For the evaluation of the syntactic correctness of a model it is indispensable to have an explicit (documented) meta model. Semantic correctness postulates that the structure and the behaviour of the model is consistent with the real world. Finally, the consistence between different models is viewed as a part of the correctness of the model [59].

While many frameworks use completeness as a quality factor of information models [1, 31], the GoM express this criteria in more relative terms.

The *guideline of relevance* postulates

- to select a relevant object system (universe of discourse),
- to take a relevant modeling technique or to configure an existing meta model adequately, and
- to develop a relevant (minimal) model system.

A model includes elements without relevance, if they can be eliminated without loss of meaning for the model user.

The *guideline of economic efficiency* is a constraint to all other guidelines. In the GAAP-context it is called the cost/benefit constraint ([9], p. 51). It is comparable to the criteria "feasibility" of LINDLAND ET AL. [27] and restricts e.g. the correctness or the clarity of a model. Approaches to support the economic efficiency are reference models, appropriate modeling tools or the re-use of models.

## 2.2 The Optional Guidelines

The pragmatic aspect of the semiotic theory [27] is integrated in the GoM by the *guideline of clarity*. Without a readable, understandable, useful model all other efforts become obsolete. This guideline is extremely subjective and postulates exactly, that the model is understood by the model user. It is not sufficient, if a model designer regard the model as understandable (see also understandability in the GAAP ([9], p. 52). "Construct overload", the situation in the framework of WAND and WEBER in which one object type of an information modeling technique map to at least two ontological constructs is an example for missing clarity as additional knowledge outside the modeling technique is required ([56], p. 211). Mainly layout conventions put this guideline in concrete terms.

The *guideline of comparability* demands the consistent use of all guidelines within a modeling project. It is one of the guidelines which corresponds directly with one GAAP principle, the comparability principle ([19], pp. 551-552). Like the GAAP which aims to increase the comparability between businesses and periods (e.g. avoid different inventory methods like LIFO and FIFO), this guideline includes e. g. the conform application of layout or naming conventions. Otherwise, two models would follow certain, but different rules. The necessity to compare information models is obvious if as-is-models and to-be-models or enterprise-specific and reference models have to be compared.

The *guideline of systematic design* postulates well-defined relationships between information models, which belongs to different views, e.g. the integration of process models with data models. Every input and output data within a process model has to be specified in a corresponding data model. Further interdependencies exist, following for example the ARIS-approach [45, 46, 47], concerning the functions (function view), the organizational units (organizational view), the results of a process (output view) and the involved applications and databases (resource view). One demand is to use a meta model which integrates all relevant views.

### 2.3 The GoM Meta Model

Within the research project Guidelines of Modeling a meta model was designed in order to structure and integrate the different project topics (figure 2, [42]). This model shows that a *perspective* is defined as a person-purpose-model-relationship. The purpose represents the intention of the modeling project. Besides the purposes the perspective is determined by the involved persons. Here are two facets of relevance: the existing methodological knowledge (expert, novice) which influences the selection and configuration of the modeling technique, and the role (model designer or user, active or reactive role), which influences the content of the model. Other, more elaborated definitions of the terms perspective and also viewpoints can be found in [6, 36].

Obviously, the guidelines vary in their perceived importance for different perspectives. For example, information models used within the phase of requirements engineering for the purpose of developing individual software and ideally automatically processed by CASE-tools call for syntactical correct models (primacy of the guideline of syntactical correctness in comparison with the guideline of clarity). In contrast to this, process models which are used to explain the business to end-users may include syntactical mistakes, if this supports compact and clear models and if the economic efficiency and the clarity is more important. Consequently, it is necessary to define also *perspective-specific guidelines*.

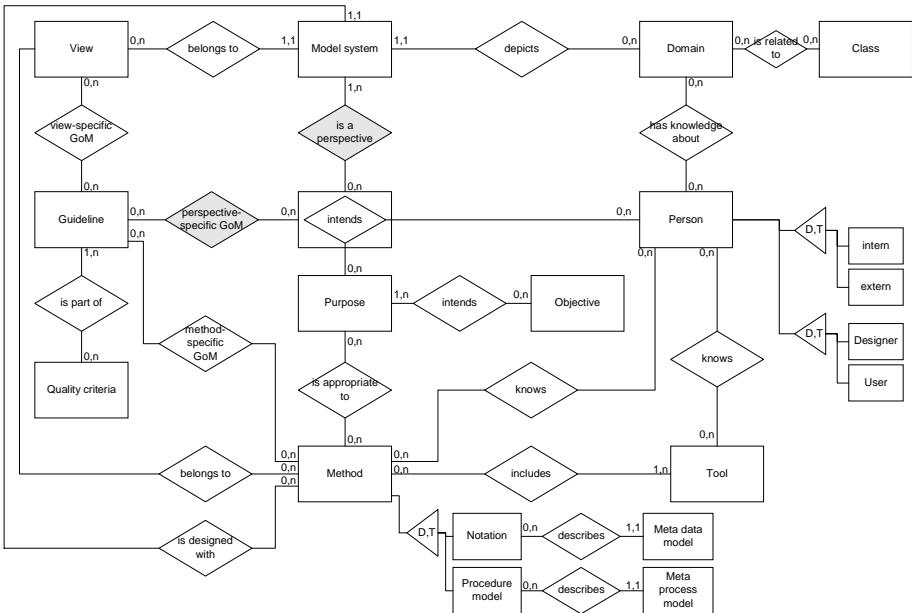

Fig. 2. The GoM meta model

In the following workflow management and simulation will be taken as two examples for popular modeling purposes. Various recommendations for these two purposes will be presented.

### 3 Guidelines for Selected Purposes of Business Process Modeling

#### 3.1 Workflow Management

The economic efficient development of workflow-based applications [26] does not only require a well considered planning and implementation of systems, but demands the efficient design of workflow models (see also [22]). Workflow models serve in all stages of system planning and development as a communication platform for those who work on the project. However, the recent discussion of workflow modeling is often focussing on syntactic questions. It neglects criteria that go beyond the notation rules and include the specific semantic context of the individual modeling process.

In order to establish standards for the design of information models it is advantageous to have a modeling technique that can be regarded as a quasi-standard (like the ER-approach [4] for data models). Currently, this is not the fact with workflow models. Every workflow management system uses rather its proprietary modeling technique. Therefore, after a workflow management system has been chosen, a revised workflow modeling according to the system-specific modeling technique is in the most cases indispensable.

Experience has shown that the general number of business process models to be transformed into workflow models is rather small. It is not unusual that a company has 100 or more business process models, but only two or three workflow models. Furthermore, concerning breadth and length, only a part of a business process model can usually be controlled workflow-based. Thus, the manual revision of workflow models often is more economic efficient than the use of interfaces (see WfMC interface no. 1). These interfaces might provide some syntactical translation but can not bridge the semantic gap between business process models and workflow models. In the following, specific recommendations for workflow modeling will be given, which focus on comparing these models with business process models. Moreover, it will be distinguished between a first workflow model that is used for selecting a workflow management system or discussing workflow alternatives, and the final executable workflow model.

#### Function View

Concerning the functions (or activities) within a workflow model, usually a n:m-relationship between business process models and workflow models exist.

Compared to organizational process models, in workflow models *manual functions* should be largely *avoided*, in particular if one follows after the other immediately. On the other hand the amount of functions rises, if the application systems or

organization units involved allow further splitting of a function. In general one can state that the granularity of the functions in workflow models are determined by a (possible) change of the organizational unit and/or the application system. Figure 3 shows how with every change of the involved organizational unit and/or the application system a new function has to be introduced. One has to consider the fact that most workflow management systems do not allow a reuse of functions. In this case, a redundant function specification is necessary.

For every function the start and end conditions should be precisely determined. In particular, it has to be indicated if the function shall be started manually or automated. As an option, for every function a deadline can be declared. When this deadline is exceeded, a higher authority can be informed, ideally the person in charge for the process (the process owner). It should be taken into account that not all workflow management systems support a hierarchical modeling.

Thus, business process models can be used as a starting point for the development of workflow models. In order to derive the workflow model, functions have to be deleted and new functions have to be modelled. For the design of an executable model, also further attributes (start and end conditions) have to be specified.

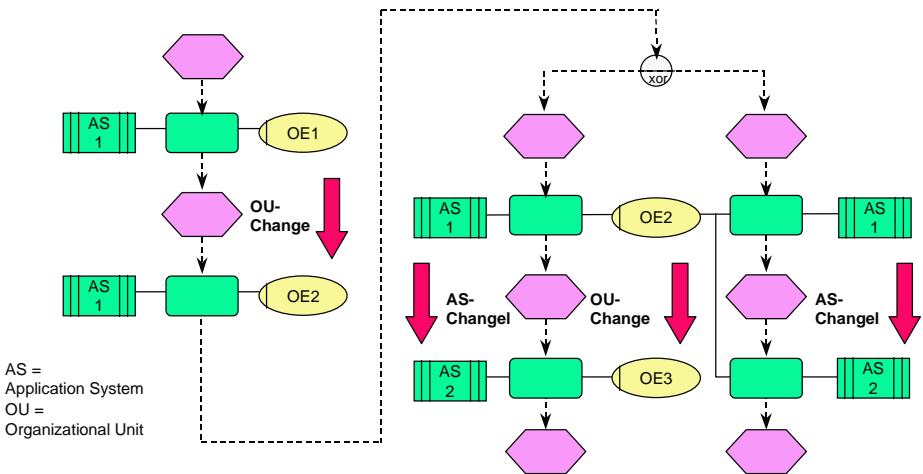

Fig. 3. Granularity of functions within workflow models

### Data View

Unlike a business process model, a workflow model requires for every function the description of the necessary *input and output data*. On the level of entity types, attributes, etc. the workflow model has to depict these input and output information. Due to the considerable modeling effort being necessary for the data view of a workflow model, only data that is critical because of the underlying interfaces has to be specified within the first workflow model. After a workflow management system is selected and an executable workflow model is required, the data view has to be

completed with information like the data type or the exact data location (database server, table, etc.).

Besides the input and output data, the *data flow* is to be described. The data flow determines the flow from the function that produces data to the function that consumes data. The data flow is restricted by the control flow as the data flow can not precede the control flow. Consequently, the control flow has to be completed before the data flow can be specified. A workflow model should include the data flow as this enables an analysis of further interfaces beyond the use of the control flow information. However, existing workflow management systems often do not allow the visualization of the data flow and show only the (local) input and output data.

### Organizational View

Every function within a workflow model must include a link to an organizational construct, if it is not completely automated and shall be executed autonomously. Relevant organizational constructs in the context of workflow management are role (in the sense of a qualification or a competence), organizational unit (permanent or temporary like a project team), position, position type and person as a static information. Figure 4 describes using an extended ER-approach the relationships between these organizational constructs. Moreover, a workflow owner should be specified for the entire workflow.

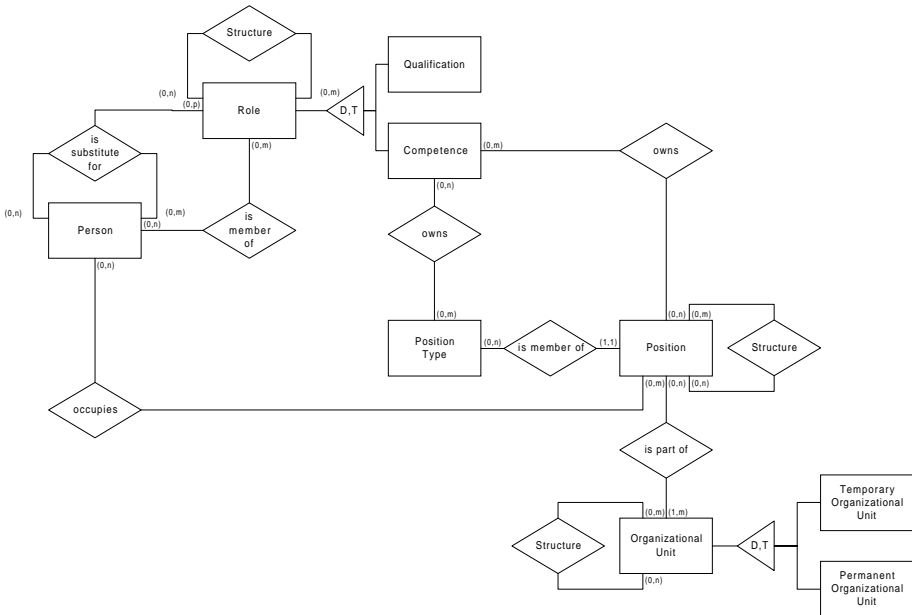

Fig. 4. A reference model for the organizational constructs within workflow models [44]



The organizational constructs in workflow management systems differentiate to a considerable extent. Concerning the assignment of organizational constructs to workflow functions, always the minimum set of organizational constructs which is required for the workflow execution has to be chosen. The organizational constructs, which are used for workflow modeling should refer to the "usual" organizational constructs of the enterprise specified in an organizational chart. If information about the workflow runtime history is of importance, (i.e. function no. 6 should be executed by the same employee who was responsible for function no. 3), a detailed note has to be placed in the workflow model (e.g., "RTH" (Run Time History)).

It has to be taken into consideration that in a workflow model the link between a function and an organizational construct means "*executes*". During the run-time the workflow management system interprets this link and the identified organizational population receives the corresponding work item. In contrast, in business process models this link often means "is responsible for".

If *several organizational constructs are connected with only one function*, there is always an XOR-relationship between them. This means that the number of at run-time addressed members of the organization is extended (e.g. procurement department, all members of a special project and Mr. Smith receive the work item). If a certain rule exists, according to which the relevant organizational constructs can be selected, but the function itself as well as the involved application systems and data are identical, a workflow-split (control flow) has to be defined. If there shall be an AND-relationship between the organizational constructs, it has to be explicitly declared at the borderline between function and organizational construct ("AND"). This could for example mean that both, task executive *and* project executive, must sign a document. Again, it should be stressed that these comprehensive modeling conventions can only apply for the general workflow model. As soon as a special workflow management system is selected, its constraints usually do not allow this elaborated specification between the workflow functions and the involved organizational constructs.

In addition to the organizational constructs, further involved resources have to be depicted. Again, it should be differentiated between a general specification of resources in a first workflow model, which serves as a basis for discussions and the executable workflow model. Only the final workflow model has to include the complete and exact specification of all involved resources. All referred IT-applications have to include specifications of the server, program parameters, etc.

### **Control View**

The control flow describes the logic relationships between the workflow functions. Whereas a linear sequence does not require special considerations (but see the requirement to specify the start and end conditions), split and join constructs are far more demanding. This is an important difference to business process models, which can easily include various splitting and joining connections without that the modeler has to be concerned about the process execution.

Possible (inclusive or exclusive) OR -splits have to be specified exactly in order to become executable by the workflow management engine. If it is not a simple

transition condition (e.g., order value > 10.000 \$), a reference has to be set that leads to an explanatory document (i.e. rules of signatures, organizational handbook). It is advantageous expressing the respective transition conditions by using dedicated nodes in the models (e.g., predicates, places or arc-inscriptions in Petri Nets or events in Event Driven Process Chains (EPC)).

As an optional construct, many workflow modeling tools allow an ELSE-exit (also: default-connector). This connector is rated as "true", if the conditions of the other corresponding connectors do not fit. This semantic relationship can be stressed by explicit indication of the relevant connector with "ELSE".

OR-Joins require special consideration as many workflow management systems execute them wrongly as an XOR-Join. While this is not critical within business process models, inclusive OR-joins demand further information about the connections, which are evaluated with true at run-time. One approach is the dead path elimination [25]. In this case, the corresponding OR-split forwards an information to the OR-join about all workflow paths, which will not be executed. With this input the OR-join has all required information for the determination of the continuation of the workflow.

Many workflow management systems demand one explicit start and final state node respectively. This is usually not required in business process models. Therefore, these nodes have to be added.

### 3.2 Simulation

Business Process Simulation (BPS) [12] has been mentioned, albeit only briefly, by many researchers as a technique that could be helpful in the context of business process change. HANSEN (1994) also advocates the appropriateness of simulation for Business Process Reengineering, arguing that "an engineering approach to process reengineering that incorporates modeling and simulation is necessary". Similarly, KETTINGER ET AL. (1997) argue that there is a need for more user-friendly and 'media-rich' capture of business processes and simulation can accommodate these requirements by providing easy visualization and allowing team participation in process redesign. v. UTHMANN and BECKER [53, 54] discuss some detailed aspects of the use of simulation within the business process management life-cycle (figure 5).

The design of simulation models, although it is a problematic task, is mostly treated as a black box. There are only some unsatisfactory isolated hints like "use refinements" or "formalize successively". For the reduction of complexity and the efficient management of designing models three principles have been established in systems engineering: the structuring of similar objectives in phases, the reuse of solution components and the application of conventions to restrict the degree of freedom. The central idea behind this is the identification of analogies in the problems and the reuse of analogous solutions. The identification and utilization of such analogies within the context of simulation models lead to phases, components and conventions.

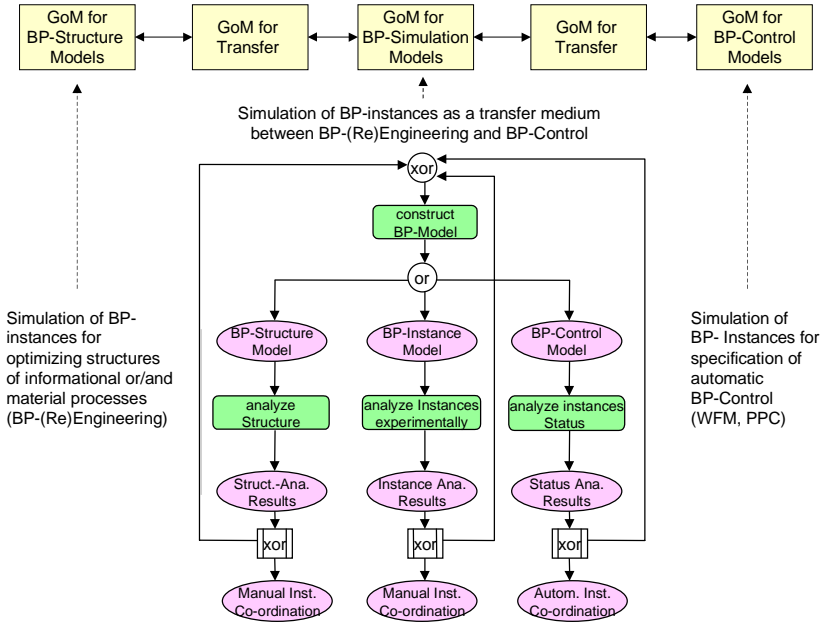

Fig. 5. Simulation within the business process management life-cycle

Model design recommendations should be applicable to a variety of simulation tools. While the phases are independent of tools the components and conventions have to be put in concrete form in terms of certain simulation modeling techniques using their specific construction elements and terminology. As a reference method higher Petri Nets [40] were chosen. Besides some other good reasons the Petri Net specific design recommendation can, thanks to their general process understanding, be transformed to other process modeling techniques pretty easily [53, 55].

A *phase model* of seven phases has been developed (figure 6, a more detailed description of the guidelines is given in [54]). The *separated* view of process object flows is directed to the purposes of processes and simplifies the process identification. This meets the BPR objective of analyzing processes without taking care about departments (= resources). In view of the widely used structure- and function-oriented process descriptions (see [18]) it can be assumed that such a view of processes is intuitively easier to understand than simulation models, especially by modeling novices, and therefore, better accepted. Processing from phase 1 to 2 leads towards a systematic successive transition from static structure models to dynamic models. A further advantage of a separated view of process object flows is that corresponding process models can easier be hierarchically refined without the assignment of resources over different levels. Traditionally, from a *function view* a process is understood as a succession of object-using, modifying and/or deleting functions (activities), and from *data view* as a succession of states corresponding to the existence of process-related objects. This differentiation is reflected in the phase model: First in phase 1 (process object flows) it is recommended to start with a

function oriented process mapping (s. above). In phase 3 the object types are specified within the static data view before the functions are procedurally (in contrast to descriptively) described in phase 4. In the phases 1 to 4 there are considered process structures, coordination mechanisms, operation and state times. Input, disturbances/changes and initial states are designed in phase 5 to 7.

The phases offer a framework to decompose the design of process simulation models in less complex subtasks. Within the phases certain objectives are to be modeled applying to specific components and conventions.

The aim of using *model components*, which can be individually composed, is a more efficient and correct model construction. There are reference simulation models in the form of context-related model components [45]. Complementary to these ones the guidelines comprise components, which are not related to concrete organizational or engineering problems, but structure context independent analogies. These *structure components* describe coordination mechanisms on different complexity levels where components can consist of less complex components (down to the elements of the meta model of the simulation language). Their higher abstraction level allows the use of these components for a simplified individual construction of simulation models from the scratch as it usually is necessary within process simulation. Moreover, the structure components help model designers to be more sensitive towards possibly relevant coordination mechanisms. The structure components are related to single objectives, and therefore, are assigned to certain construction phases.

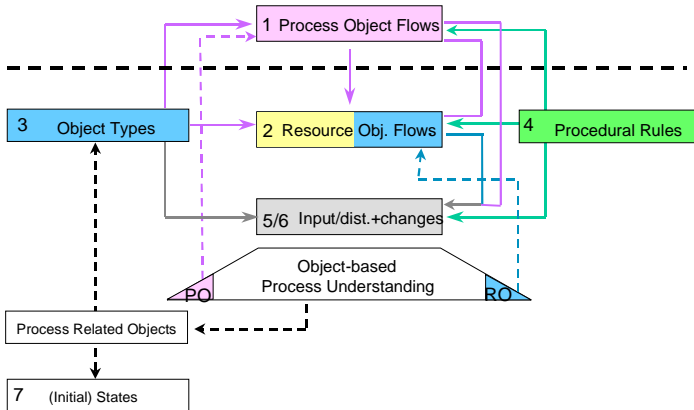

**Fig. 6.** Phase model for simulation model design

Finally, some *design conventions* should be presented. Methods of process modeling contain generally just a set of syntactic rules, which give model designers a wide degree of freedom. Therefore, one objective can be depicted in (different) models which are correct but do not have sufficient quality, e. g. they are misleading or badly arranged. This has to be taken into account especially because of the (in simulation models) usually high number and variety of involved model designers and users of model. Conventions are supposed to restrict this freedom and lead to a higher quality. One important intention of this is to ensure a uniform, clear (GoM-principle

of clarity) and unequivocal understanding of models of all involved users. A further important aspect of model conventions is the support of coping with the requirements perspectives. Important conventions for simulation models refer especially to the use of terminology, topology, start and end markings of processes, the visualization of process and resource object types (including the media type) within their organizational context, documentary aspects and the explication of different views (e.g. data, function and organizational view). For the definition and consolidation of terms the use of a business term model is proposed. Besides the discussed semantic aspects the performance of simulation models has to be taken into account.

## 4 Techniques for Adjusting Models to Perspectives

Perspectives on process models can be distinguished by the involved persons and by the modeling purpose. While a process model which specifies a workflow has to depict among others the control flow, the data flow and program parameters (see section 3.1), a model which is used within an organizational handbook or for certification purposes includes mainly organizational facts (process owner, roles, etc.). A rough impression of the great variety of perspectives on information models which exists especially concerning process models can be found in figure 7.

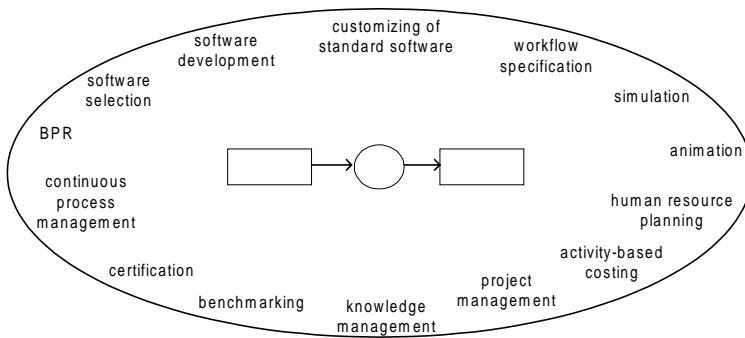

**Fig. 7.** Potential perspectives on process models [42]

Within the research project Guidelines of Modeling we identify, characterize and compare these perspectives using empirical studies. In the following, this paper is not concentrating on these content-specific questions, but it will be discussed how perspectives can methodically be distinguished. Six ways of customizing different perspectives will be explained. They have an adjunctive relationship to each other, which means that they can be used in combination. As an application of the guideline of relevance they suppose to reduce the model complexity for every individual perspective.

#### 4.1 Different Layout Conventions

Different layout conventions exist, if the models of two perspectives concerning the number and the naming of the information objects are identical, but different in their representation (aesthetics). This kind of model differentiation is more determined by the way of using the model than by the model content. It can be realized with "reasonable effort", if the placement is identical and only form, color, size, etc. of the objects are different. The transformation of "typical" information models with cycles and squares into more colorful, more or less self-explainable models is important to gain the acceptance in the business departments. Figure 8 portrays, taking ARIS Easy Design as an example [20], how a process model designed for end users from business departments can look like (see also [30] for a similar approach).

Different layout conventions become much more difficult to handle, if also the placement of the information objects can vary. One example in (large) data models is that different entity types are of different importance for different users. As a consequence, in every model different entity types should be right in the middle of the model, the area of most attention. For that, sophisticated algorithms are necessary, which optimize models concerning metrics like the minimal (average, maximum) length of edges, the minimal number of crossings, or the minimal drawing area [2, 34, 51]. Potential constraints are that only two directions are allowed (vertical, horizontal) or symmetries have to be stressed (e.g. sons in hierarchies).

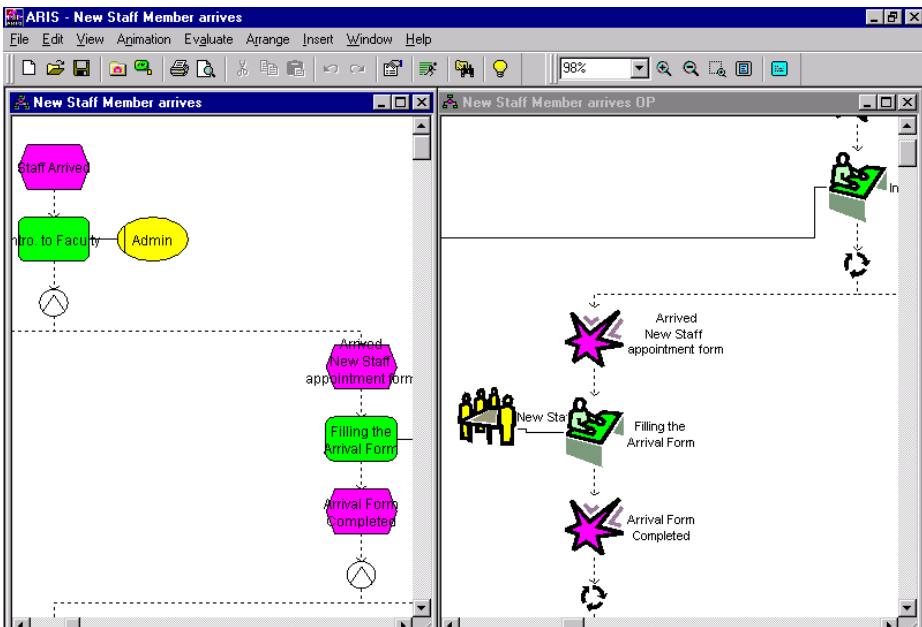

Fig. 8. A process model in ARIS Easy Design [20]

## 4.2 Different Naming Conventions

A different naming in models related to different perspectives is of high importance in distributed, especially international modeling projects and requires the possibility to administer synonyms for the relevant model constructs. It is recommended to use a *business term catalogue*, which defines and relates the main terms within a company ([23], pp. 127-133). Furthermore, one cluster of the business term catalogue should as a part of the meta model define the constructs, which are relevant for information modeling (e.g. entity type, cardinality) [50]. Between the single business terms exist typical semantic relationships like "is related to", "classifies", "is part of", "is a" or "is synonym of". A business term catalogue should substitute existing (textual) glossaries and be as far as possible completed before the process modeling activities start. The attributes of the business terms contain links to the different purposes and characterize a term e.g. as a software-specific term (e.g. "Company Code" within SAP R/3) or to specific qualifications (e.g. the German term "Unternehmen" for model users familiar with German). The user or the user group has corresponding attributes, so that for every user (group) the adequate terms can be selected automatically.

## 4.3 Different Information Objects

In comparison with different layout or naming conventions the perspectives are much more individual, when different information objects are relevant for them. For example, a workflow developer would not be interested in a detailed description of the manual functions within a process, while someone who is responsible for the implementation of activity-based costing may be especially interested in these time-consuming functions (see also [43] for a comparison of workflow management and activity-based costing requirements). On the other hand, batch-tasks depicted in a process model may be not important for someone who is writing an organizational handbook, while they have a specific meaning for the person who is responsible for the customization of ERP software. In a next step the importance of the attributes of every object or the appropriate degree of specialization can be discussed for every perspective. It is not only the purpose but also the role, which determines the relevant objects. For example, a doctor has got another perspective on the same process than the patient and the person who allows traveling expenses another one than the person who applies for them (see for another example ([28], pp. 60-61)). Thus, different perspectives can be characterized as *different projections on one common model*. Though this is very expensive to realize as it requires a relationship from every object to the relevant perspectives, it is one of the most important forms to characterize individual perspectives.

#### 4.4 Different Information Object Types

In some cases the requirements of different perspectives can be generalized in a way, that between the perspective and the information object types (e.g. entity type, organizational unit type, etc.) of the common meta model a relevance relationship can be identified. That means, different perspectives can be characterized as *different projections on a common meta model*. For example, it is indispensable to depict the object type role in a workflow model, while in ERP-specific reference models like the ones from SAP [5] or BAAN [13] system organizational units (e. g. company code, plant or sales organization in SAP R/3) are relevant.

This requirement is already realized in some modeling tools. For example, ARIS-Toolset is offering method filters which reduce the meta model in a way that the user is not confronted with the over-complexity resulting out of a non-appropriate modeling technique [20].

#### 4.5 Different Use of a Process Modeling Technique

The high number of different modeling techniques with a common root (e. g. Entity Relationship model or Petri Nets) leads to the fact, that in many cases perspectives can be distinguished because they are slightly different in their meta model. As an explanation, the event-driven process chains (EPC) are taken as an example [45, 46]. EPC consist mainly of functions, events and control flow connectors. One notation rule, which was stressed about the EPC, is that an OR-split never succeeds directly an event. Nonetheless, in the most important book which is using the event-driven process chains, "Business Process Engineering" [45] the included reference models do not consider this rule (to get a higher clarity, because of shorter processes).

This kind of perspective differentiation requires individual rules to transform one model into the other. It is one objective of the Guidelines of Modeling to identify for widespread modeling techniques like the ERM or event-driven process chains typical differences in using the meta model and as far as possible to prioritize one alternative (see [41] for examples for the event-driven process chains).

#### 4.6 Different Meta Models

As the first five approaches assume that one modeling technique serves for all the different perspectives, the requirements for such a language are quite high [36]. Single perspectives have got the highest degree of individualization if they are designed with different modeling techniques. Therefore, they already can be distinguished by the underlying meta models. Such a differentiation may be necessary, if a BPR-project requires easy to understand models designed for example with event-driven process chains, while the introduction of workflow management requires precise Petri Nets and the increase of the customer orientation of the processes needs customer-supplier-protocols [48]. If this form of perspective



differentiation is tolerated within a modeling project, it is recommended to design relationship meta models: meta models which relate the elements and relationships of the involved modeling techniques to each other [33]. They can be used for the horizontal model transformation (within analysis) and for the vertical model transformation (from analysis to design).

## 5 Summary and Outlook

A continuously growing number of different purposes for process modeling, of involved model designers and model users, and available comprehensive modeling tools increases the complexity of process modeling. Thus, the management of the quality of process models is becoming challenging.

This paper presented a framework called Guidelines of Modeling (GoM), which structures different quality criteria and levels of abstraction in two dimensions. We discussed the six guidelines of correctness, relevance, economic efficiency, clarity, comparability and systematic design (section 2). Workflow management and simulation were taken as examples in order to put the modeling recommendations in concrete terms for two selected purposes (section 3). More general, six different techniques for the differentiation of process models for alternative purposes were presented (section 4). The introduced concepts offer less experienced model designers some hints for a systematic and adequate design of process models. The overall GoM architecture and the detailed recommendations make more sensitive for critical quality factors beyond the consistent use of a modeling technique.

The aim of the further work is the design of a "comprehensive" set of guidelines for process models with Petri Nets as the uniform reference modeling technique within the entire process life-cycle [10, 11]. Modeling Guidelines should force to construct the common elements adequately for the core purposes of process modeling, namely Business Process (Re)Engineering, workflow management and simulation [53]. Furthermore, we are currently analyzing the potential for the integration of an IS-related ontology into the GoM-framework. First results taking the Bunge-Wand-Weber models [57] can be found in [17].

## References

- [1] Batini, C., Ceri, S., Navathe, S. B.: Conceptual Database Design. An Entity-Relationship - Approach. Benjamin Cummings, Redwood City, California (1992)
- [2] Batini, C., Furlani, L., Nardelli, E.: What is a good diagram? A pragmatic approach. In: Chen, P. P.-S. (ed.): Proceedings of the 4<sup>th</sup> International Conference on the Entity-Relationship Approach: The Use of ER Concept in Knowledge Representation. Elsevier, North-Holland, 312-319
- [3] Becker, J., Rosemann, M., Schütte, R.: Guidelines of Modelling (GoM). *Wirtschaftsinformatik* 37 (1995) 5, 435-445 (in German)

- [4] Chen, P. P.-S.: The Entity-Relationship Model: Toward a Unified View of Data. *ACM Transactions on Database Systems* 1 (1997) 1, 9-36
- [5] Curran, Th., Keller G.: *SAP R/3. Business Blueprint: Understanding the Business Process Reference Model*. Prentice Hall, Upper Saddle River (1998)
- [6] Darke, P., Shanks, G.: Stakeholder Viewpoints in Requirements Definition: A Framework for Understanding Viewpoint Development Approaches. *Requirements Engineering* 1 (1996), 85-105
- [7] Davenport, T.H.: *Process Innovation: Reengineering Work Through Information Technology*. Boston, Massachusetts (1992)
- [8] Davenport, T.H., Short, J.E.: The New Industrial Engineering: Information Technology and Business Process Redesign. *Sloan Management Review* 31 (1990) 4, 11-27
- [9] Davis, M., Paterson, R., Wilson, A.: *UK GAAP: Generally Accepted Accounting Principles in the United Kingdom*. 5<sup>th</sup> ed., Clays Ltd, Bungay, Suffolk (1997)
- [10] Deiters, W.: Information Gathering and Process Modeling in a Petri Net Based Approach: Part III, Chapter 1 of this volume
- [11] Deiters, W.; Gruhn, V.: The Funsoft Net Approach to Software Process Management. *International Journal of Software Engineering and Knowledge Engineering* 4 (1994) 2, 229-256
- [12] Desel, J., Erwin, T.: Simulation of Business Processes: Part II, Chapter 2 in this volume
- [13] van Es, R. M.; Post, H. A.: *Dynamic Enterprise Modeling. A Paradigm Shift in Software Implementation*. Kluwer, Deventer (1996)
- [14] Georgakopoulos, D.; Hornick, M., Sheth, A.: An Overview of Workflow Management: From Process Modeling to Workflow Automation Infrastructure. *Distributed and Parallel Databases* 3 (1995) 2, 119-153
- [15] Green, P., Rosemann, M.: An Ontological Analysis of Integrated Process Modelling. In: Jarke, M., Oberweis, A. (eds.): *Advanced Information Systems Engineering. Proceedings of the 11<sup>th</sup> International Conference - CAiSE '99. Lecture Notes in Computer Science, Vol. 1626*. Springer-Verlag, Berlin et al. (1999), 225-240
- [16] Hammer, M.: *Reengineering Work: Don't Automate, Obliterate*. *Harvard Business Review* 68 (1990) 4, 104-112
- [17] Hammer, M., Champy, J.: *Reengineering the Corporation: a Manifesto for Business Revolution*. London (1993)
- [18] Hess, T., Brecht, L.: *State of the Art des Business Process Redesign: Darstellung und Vergleich bestehender Methoden*. 2<sup>nd</sup> ed., Gabler-Verlag, Wiesbaden (1996) (in German)
- [19] Horngren, Ch. T.; Harrison, W. T.: *Accounting*, 2<sup>nd</sup> ed. Prentice Hall, Englewood Cliffs, New Jersey (1992)
- [20] IDS Scheer AG: *ARIS Methods. Version 4.1*. Saarbrücken (1999)
- [21] Ishikawa, K.: *What is Total Quality Control? The Japanese Way*, Prentice Hall, Englewood Cliffs (1985)
- [22] Janssens, G. K., Verelst, J., Weyn, B.: Techniques for Modelling Workflows and their Support of Reuse: Part I, Chapter 1 in this volume
- [23] Kirchmer, M.: *Business Process Oriented Implementation of Standard Software*. Springer-Verlag, Berlin et al. (1998)
- [24] Krogstie, J., Lindland, O. I., Sindre, G.: Towards a Deeper Understanding of Quality in Requirements Engineering. In: Iivari, J., Lyytinen, K., Rossi, M. (eds.): *Proceedings of the 7<sup>th</sup> International Conference on Advanced Information Systems Engineering – CAiSE '95*. Springer-Verlag, Berlin et al. (1995), 82-95
- [25] Leymann, F., Altenhuber, W.: Managing business processes as information resources. *IBM Systems Journal* 33 (1994) 2, 326-348

- [26] Leymann, F., Roller, D.: Workflow-based applications. *IBM Systems Journal* 36 (1997) 1, 102-123
- [27] Lindland, O. I., Sindre, G., Sølvsberg, A.: Understanding Quality in Conceptual Modeling. *IEEE Software* 11 (1994) 2, 42-49
- [28] Macaulay, L. A.: *Requirements Engineering*, Springer-Verlag, Berlin, Heidelberg, New York (1996)
- [29] Miller, M. M.: *Comprehensive GAAP Guide*. Harcourt Brace Jovanovich, Publishers, San Diego et al. (1988)
- [30] Moody, D. L.: Graphical Entity Relationship Models: Towards a More User Understandable Representation of Data. In: Thalheim, B. (ed.): *Proceedings of the 15<sup>th</sup> International Conference on Conceptual Modeling: Conceptual Modeling – ER '96*. Springer-Verlag, Berlin et al. (1996), 227-244
- [31] Moody, D. L.; Shanks, G. G.: What makes a Good Data Model? A Framework for Evaluating and Improving the Quality of Entity Relationship Models. *The Australian Computer Journal*, 30 (1998) 3, 97-110
- [32] Moddy, D. L.; Shanks, G.: Improving the Quality of Entity Relationship Models: An Action Research Programme. In: Edmundson, B., Wilson, D. (eds.): *Proceedings of the 9<sup>th</sup> Australasian Conference on Information Systems*. Vol. II, Sydney (1998), 433-448
- [33] Nissen, H. W., Jeusfeld, M. A., Jarke, M., Zemanek, G. V., Huber, H.: Managing Multiple Requirements Perspectives with Metamodels. *IEEE Software* 13 (1996) 3, 37-48
- [34] Nummenmaa, J.; Tuomi, J.: Constructing layouts for ER-diagrams from visibility-representations. In: Kangassalo, H. (ed.): *Proceedings of the 9<sup>th</sup> International Conference on the Entity-Relationship Approach - ER '90: Entity-Relationship Approach*. Elsevier, North-Holland (1991), 303-317
- [35] Oakland, J.S.: *Total Quality Management: The Route to Improving Performance*. 2<sup>nd</sup> ed., Nichols Publishing, New Jersey, NJ, (1993)
- [36] Opdahl, A. L.: Towards a faceted modelling language. In: Galliers, R. et al.: *Proceedings of the 5<sup>th</sup> European Conference on Information Systems - ECIS '97*. Cork 1997, 353-366
- [37] Pagnoni, A.: *Management-oriented Models of Business Processes: Part I*, Chapter 7 in this volume
- [38] Pereira, V., Paterson, R., Wilson, A.: *UK/US GAAP Comparison*. 3<sup>rd</sup> ed., Briddles Ltd, Guildford and King's Lynn (1994)
- [39] Poirier, C. A.: *Advanced Supply Chain Management: How to Build a Sustained Competition*. Publishers' Group West (1999)
- [40] Reisig, W.: *Petri Nets - An Introduction*. Berlin (1985)
- [41] Rosemann, M.: *Complexity Management in Process Models*. Gabler-Verlag, Wiesbaden (1996) (in German)
- [42] Rosemann, M.: Managing the Complexity of Multiperspective Information Models using the Guidelines of Modeling. In: Fowler, D., Dawson, L. (eds.): *Proceedings of the 3<sup>rd</sup> Australian Conference on Requirements Engineering*. Geelong (1998), 101-118
- [43] Rosemann, M., Green, P.: Enhancing the Process of Ontological Analysis - The "Who cares?" Dimension. In: Dampney, K. (ed.): *Proceedings of the IS Foundations-Workshop*. Sydney, 29. September (1999)
- [44] Rosemann, M., zur Mühlen, M.: Evaluation of Workflow Management Systems - a Meta Model Approach. *Australian Journal of Information Systems* 6 (1998) 1, 103-116
- [45] Scheer, A.-W.: *Business Process Engineering*. 3<sup>rd</sup> ed., Springer-Verlag, Berlin et al. (1998)
- [46] Scheer A.-W.: *ARIS - Business Process Modeling*. 2<sup>nd</sup> ed. Berlin et al. (1999)

- [47] Scheer, A.-W., Nüttgens, M: ARIS Architecture and Reference Models for Business Process Management, Part III, Chapter 8 in this volume
- [48] Scherr, A. L.: A new approach to business processes. *IBM Systems Journal* 32 (1993) 1, 80-98
- [49] Schütte, R., Rotthowe, Th.: The Guidelines of Modelling as an approach to enhance the quality of information models. In: Ling, T. W., Ram, S., Lee, M. L. (eds.): *Conceptual Modeling - ER '98*. 17<sup>th</sup> International ER-Conference, Singapore, November 16-19, 1998. Springer-Verlag, Berlin et al. (1998) 240-254
- [50] Spencer, R., Teorey, T.; Hevia, E.: ER Standards Proposal. In: Kangassalo, H. (ed.): *Proceedings of the 9<sup>th</sup> International Conference on the Entity-Relationship Approach – ER '90: Entity-Relationship Approach*. Elsevier, North-Holland (1991), 425-432
- [51] Tamassia, R., Di Battista, C., Batini, C.: Automatic graph drawing and readability of diagrams. *IEEE Transactions on Systems, Man, and Cybernetics* 18 (1988) 1, 61-78
- [52] Tunney, P.B., Reeve, J.M.: The Impact of Continuous Improvement on the Design of Activity Based Cost Systems. *Journal of Cost Management* (1992) 43-50
- [53] von Uthmann, C., Becker, J.: Petri Nets for Modeling Business Processes - Potentials, Deficits and Recommendations. In: *Proceedings of the Colloquium on Petri Net Technologies for Modelling Communication Based Systems*. Berlin 1999 (to appear)
- [54] von Uthmann, C., Becker, J.: Guidelines of Modeling (GoM) for Business Process Simulation. In: Scholz-Reiter, B., Stahlmann, H.-D., Nethe, A. (eds.): *Process Modeling*. Berlin, Heidelberg (1999)
- [55] van der Aalst, W.M.P., van Heh, K.M.: Business Process Redesign: A Petri-net-based approach. *Computers in Industry* 29 (1996) 1-2, 15-26
- [56] Wand, Y.; Weber, R.: On the deep structure of information systems. *Information Systems Journal* 5 (1995) 3, 203-223
- [57] Weber, R.: *Ontological Foundations of Information Systems*. Coopers & Lybrand Accounting Research Methodology Monograph No. 4, Melbourne (1997)
- [58] Womack, J. P., Jones, D. T., Roos, D.: *The Machine That Changed the World: The Story of Lean Production*. Harpercollins (1991)
- [59] Zamperoni, A., Löhr-Richter, P.: Enhancing the Quality of Conceptual Database Specifications through Validation. In: Elmasri, R. A., Kouramajian, V., Thalheim, B. (eds.): *Proceedings of the 12<sup>th</sup> International Conference on the Entity-Relationship Approach – ER '93*. Springer-Verlag, Berlin et al. (1993), 85-98