

Hallway Monitoring: Distributed Data Processing with Wireless Sensor Networks

Tobias Baumgartner, Sándor P. Fekete, Tom Kamphans, Alexander Krölller,
and Max Pagel

Braunschweig Institute of Technology, IBR, Algorithms Group, Germany
{t.baumgartner,s.fekete,t.kamphans,a.kroeller,m.pagel}@tu-bs.de

Abstract. We present a sensor network testbed that monitors a hallway. It consists of 120 load sensors and 29 passive infrared sensors (PIRs), connected to 30 wireless sensor nodes. There are also 29 LEDs and speakers installed, operating as actuators, and enabling a direct interaction between the testbed and passers-by. Beyond that, the network is heterogeneous, consisting of three different circuit boards—each with its specific responsibility. The design of the load sensors is of extremely low cost compared to industrial solutions and easily transferred to other settings. The network is used for in-network data processing algorithms, offering possibilities to develop, for instance, distributed target-tracking algorithms. Special features of our installation are highly correlated sensor data and the availability of miscellaneous sensor types.

Keywords: Sensor Networks, Testbeds, Data Processing, Target Tracking, Load Sensors.

1 Introduction

In the research field of wireless sensor networks, a tremendous amount of fundamental work over the past years has focused on protocol design and algorithm development. This has led to a high availability of common routing [3], time-synchronization [17], localization [4], and clustering [1] algorithms—often designed for general sensor network topologies. Similarly, many testbeds [9,15,18] were built during that time to run these algorithms on real sensor nodes. This became possible due to both dropping hardware costs and the maturing of operating systems running on the nodes, simplifying the development process. Due to the mainly common demands of the algorithms, most of the available testbeds were also held generic; the main focus was on the principal functionality of the algorithms and protocols, the aim being real-world communication behavior and implementations on tiny micro-controllers.

With the ongoing progress of algorithmic methods and system technology, it becomes possible as well as important to apply the previously designed basics to real application areas—thereby often adapting a generic solution to the specific needs of a single deployment. Such application areas for wireless sensor networks are quite dispersed. Deployments vary from monitoring environmental

areas such as volcanos or mountain sides, over personal area networks in medical applications, to home automation systems.

Building such real-world applications with actual sensor data processing is still a challenging task. First, the installation of specialized sensors often requires a significant amount of additional work. Second, such sensors may also cost much more than the nodes themselves—and thus are often not affordable for ordinary sensor network testbeds.

The design, development, and evaluation of higher-level algorithms in real deployments in which sensor nodes can share their local knowledge to obtain global goals requires appropriate sensor data. To carry out such tests, we developed a hallway monitoring system, consisting of 120 load sensors deployed beneath the hallway floor, and 29 passive infrared sensors (PIRs) for motion detection. The construction of the load sensors has already been demonstrated in [5]. The sensors are connected to nodes, which in turn can then exchange the measured values. The data is highly correlated, therefore serving as an ideal testbed for any algorithm performing data aggregation or in-network data analysis, such as distributed tracking algorithms.

The floor consists of square floor tiles with a side length of 60 cm each, which are installed on small metal columns. The setup is shown in Fig. 1.

We installed one load sensor on each of these columns. Therefore the corners of four floor tiles rest on each sensor, and vice versa each floor tile is monitored by four sensors. Every four load sensors are connected to a sensor node, which is also installed beneath the floor. Altogether, the setup consists of 120 load sensors, 29 PIR sensors, and 30 sensor nodes. The hallway has a width of 3 meters (corresponding to 5 tiles), and a length of 21.6 meters.

We designed the load sensors ourselves, with a surprisingly cheap construction. One load sensor costs about 25 Euros—as opposed to around 200 Euros for industrial manufactured load cells. The lower price comes with a loss of accuracy, but this loss can be compensated by sophisticated algorithms for sensor networks, where the nodes do in-network processing of the highly correlated data.

The rest of the paper is structured as follows. Section 2 describes similar constructions and related work. In Section 3, the hallway monitoring system is presented in detail. In Section 4, we report on how the sensor network can be accessed by the public. Section 5 describes first experimental results with the load sensors. We conclude the paper in Section 6.

2 Related Work

The development of a sensing floor has been proposed by other authors, but not in the context of a sensor network, which is crucial for high-level methods and applications. Addlesee et al. [2] present a design with 3x3 tiles placed on load cells. Similarly, Orr and Abowd [13] designed the Smart Floor, also based on load cells. Neither of the authors considered a sensor network scenario.

While the above approaches make use of expensive load cells, Yiu and Singh [19] and Kaddoura et al. [10] presented designs based on force sensors. Like in



(a) The installation site.



(b) Floor tiles rest on columns.

Fig. 1. Hallway monitoring scenario

the other cases, there is no distributed data processing, and the system allowed only for presence detection, as opposed to more complex information such as the fine-grained resolution of a single step.

Mori et al. [11,12] present both a sensing room with pressure sensors on the floor and also the furniture, and a sensing floor, which they use to identify people

via their gaits. The latter, gait recognition for people identification, has also been done by Qian et al. [14]. Again, there is no distributed in-network analysis by small devices like sensor nodes. In contrast to the previous descriptions, we present a both simple and highly affordable solution for hallway monitoring. In addition, our construction allows for the design of sophisticated algorithms running on tiny sensor nodes.

In general, the possibility of target tracking in indoor environments is especially interesting in the field of Ambient Assisted Living (AAL). Elderly, impaired, or disabled people are to be supported by technical solutions integrated in their homes. Gambi and Spinsante [7] present a localization and tracking system based on multiple cameras. In [8], Jin et al. analyze the performance of using accelerometers for AAL. However, having multiple cameras at home comes with a certain discomfort, as well as the need of constantly wearing sensors when at home. Our approach can work fully transparent for inhabitants, by offering the same features as above.

3 Hallway Construction

We have built a hallway monitoring system in our institute. To this end, we designed 120 load sensors, which were installed beneath the floor tiles in our hallway. A single load sensor and an exemplary section of the installation are shown in Fig. 2. There are also 29 PIR sensors on the walls to allow combining different kinds of sensor values in one distributed application. The sensors are connected to a total of 30 iSense [6] nodes, which can communicate over their radio. Finally, there are also actuators installed—29 light-emitting diodes (LEDs) and speakers to play sound samples—that are controlled by the sensor nodes, and thus enhance debugging possibilities of newly designed algorithms. A schematic diagram of the whole hallway construction with the interconnections of the several components is shown in Fig. 3. In the following, each part is described in detail.

3.1 Load Sensors and PIRs

We present a simple—and most notably low-cost—mechanism of building a single load sensor for our application. We use strain gauges, which are able to measure minimal strains in the objects to which they have been glued to. These strain gauges are supplied with a voltage of a few Volts, whereby they provide an output voltage of just a few millivolts. Whenever the attached material is strained or deformed, even by a few nanometers, the output current changes. Such sensors cost only a few Euros (around 10 Euros apiece in our case).

The strain gauges are attached to small steel plates with a size of approx. 10x4 cm. We used spring steel for the base construction. The advantage of spring steel is that it is flexible enough to be strained by the weight of a person, but also solid enough not to be permanently deformed. Installing the steel plates under the floor is surprisingly difficult. Strain gauges measure strains in different

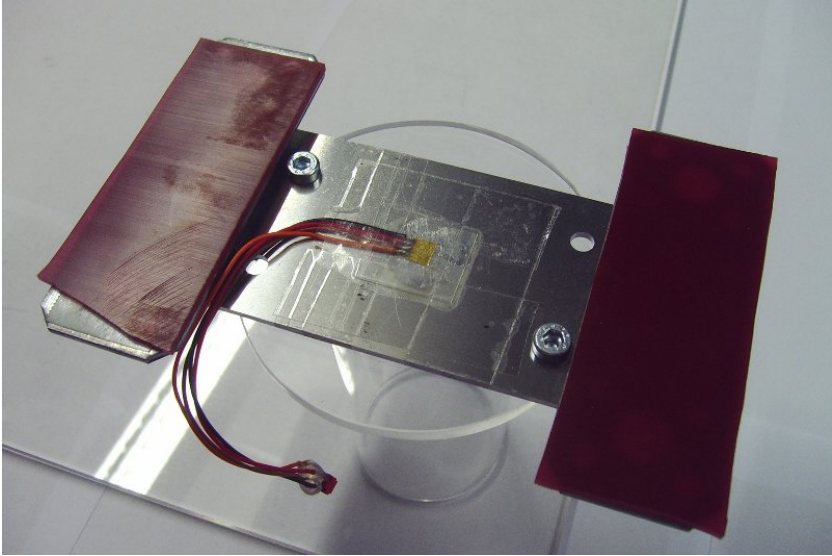

(a) A single load sensor.



(b) Load sensors attached to iSense node.

Fig. 2. Load sensor installation

directions. If strain is applied from perpendicular directions, they annihilate each other, and the sensor does not measure any force. Hence, we enhanced the construction to deal with this issue. We use two additional steel plates, each with a spacer. The final construction is shown in Fig. 2(a). Like the strain gauges, the steel construction is surprisingly cheap. We paid around 15 Euros apiece.

Finally, the load sensors were installed in the hallway. The floor consists of square floor tiles with a side length of 60 cm each, which rest on small metal columns. We installed one load sensor on each of these columns—resulting in a total of 120 sensors beneath the floor. The sensor data is highly correlated, since the corners of four floor tiles rest on each sensor, and vice versa each floor tile is monitored by four sensors. The setup is shown in Fig. 2(b), where three floor tiles were removed to provide a view of the installation beneath the floor.

In addition to the load sensors beneath the floor, we installed 29 PIR sensors for motion detection on the walls. Each sensor is placed in a height of 2.5m, directed approx. 45° downwards. There are always two sensors face to face with each other, enabling the observation of a section of the hallway.

This facilitates identifying people by weight, but also by their motion when passing through the hallway. The different kinds of sensor values can then be combined to allow for the development of algorithms for heterogeneous sensor types.

3.2 Actuators

In contrast to the load sensors and PIRs, we have also added actuators to the hallway. There is a total of 29 lights and speakers installed on the walls. Each actuator consists of a so-called media board, which is an extra circuit consisting of an Atmega48, nine LEDs (three red, three green, three blue) attached to a cooling element, a speaker connected to the PWM output of the microcontroller, and a 4 GB microSD card for storing sound samples played through the speaker. Each media board is connected via UART to one sensor node beneath the floor, and can thus be used as an actuator for direct interaction with people passing the floor.

3.3 Sensor Nodes

Since the strain gauges have an output of just a few millivolts, they cannot be measured using ordinary ADCs. We use an additional amplifier circuit, to which up to six strain gauges can be attached. The circuit can power the sensors, and also read out and amplify the sensor output. It bears an Atmega48, which provides multiple ADC ports to read out the sensor values. The circuit has been designed to be used directly with our iSense sensor node platform [6], and communicates with the Atmega48 on the amplifier circuit via SPI. Even though it is iterated over up to six ADCs on the Atmel, and the data is additionally transmitted via SPI, we achieve a data transfer rate of 800 Hz per load sensor. This allows for highly fine-grained data-processing, and can lead to analyzing even single steps of passing people.

In addition to the connection to the load sensors, the iSense nodes are also wired to the PIR sensors and actuators on the wall. The whole setup is shown in Fig. 3. Each wireless sensor node is connected to four load sensors, one PIR, and one actuator unit—due to a diverging corridor one wall installation is missing, resulting in one iSense node without a PIR and LED/speaker unit connected.

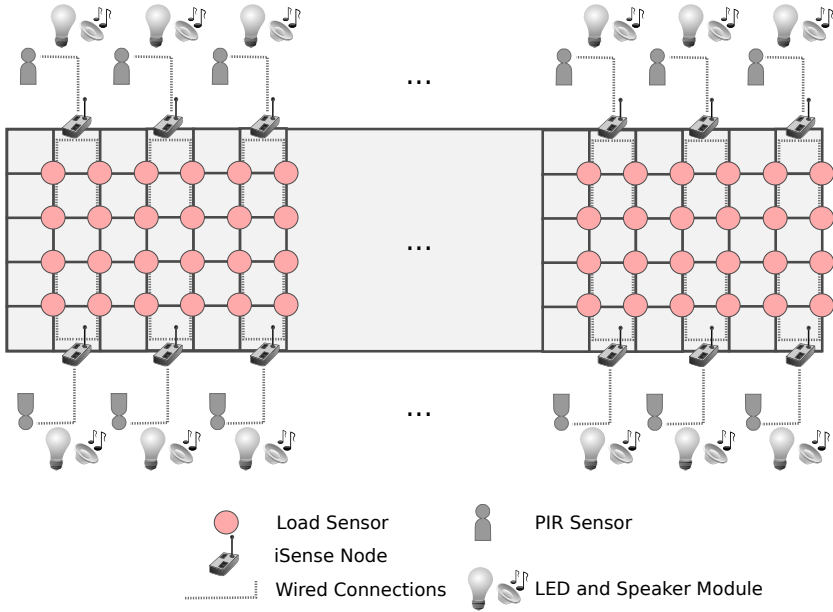

Fig. 3. Hallway construction with different kinds of sensors and actuators

The iSense nodes can then be used for the implementation of high-level data processing algorithms. For example, by exchanging actual data over the radio, the nodes can track people walking through the hallway.

For debugging purposes, the iSense nodes are connected via USB to a backbone of several PCs. The nodes are powered via this connection. In addition, they can be re-programmed, and debugging data can be collected continuously and reliably.

4 Software Access

There are two possibilities of accessing the sensor nodes in the hallway: First, there is an open API offered via web services. Second, we implemented a Java-based GUI for simple and fast algorithm development offering a central view on the network.

4.1 WISEBED API

The testbed was built in the context of the EU-project WISEBED [16], which aims at the interconnection of different sensor network testbeds spread over Europe. One goal of the project is to allow the connection of several testbeds and make them appear as only one testbed for a user. Moreover, we aim at allowing users to connect their own testbeds to one that is part of WISEBED. Therefore, all APIs that are needed to access a testbed and its sensor nodes are

open to the public. Sensor nodes can be re-programmed, messages can be sent to the nodes, and debugging output can be collected. All APIs are based on web services for platform independence.

Since our testbed is part of the WISEBED project, our hallway monitoring system will be made available for the public—there is, of course, also a user management and reservation system offered.

4.2 CoCoS - Java-Based GUI

To facilitate the access to the sensor floor and enable users to develop their own software, we developed a simple to use Java API which gives access to the hallway. The so-called “Corridor Control System” (CoCoS) consists of a client-server solution which allows multiple clients to access the floor simultaneously. The server is embedded as a pluggable module in the WISEBED API and is able to fully control the floor.

CoCoS provides a real-time global view of the sensor floor, which can be easily accessed to program custom extensions, evaluate sensor data, or send commands to the sensor floor. Another feature is to write out sensor data traces, which can be played back later to run different algorithms on the same data, or work off-line without a connection to the hallway. The server does not provide a graphical user interface, but it is possible to connect a GUI-client to the server via TCP/IP that offers a graphical visualization of the current floor status, see Fig. 4. It is also possible to start an extension from the client to remotely control the corridor, which makes it possible to work with the testbed from anywhere.

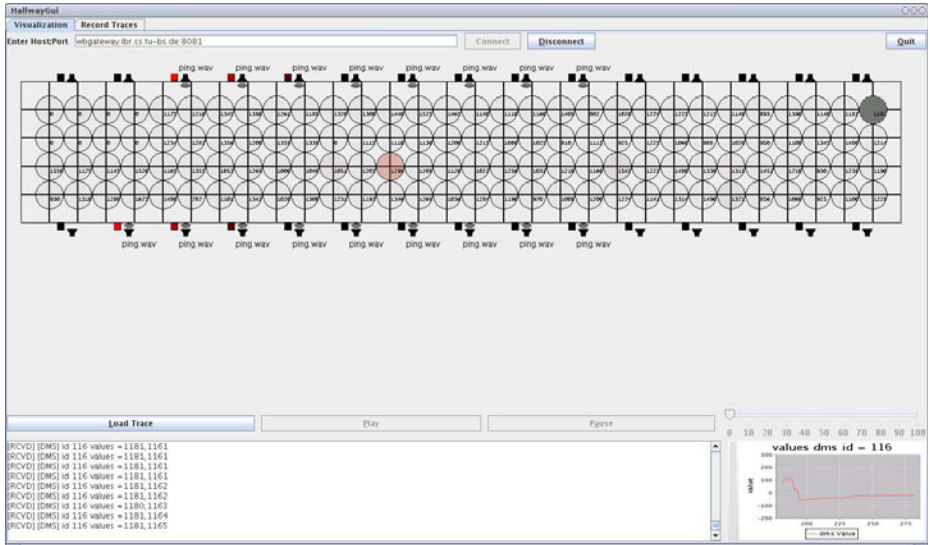
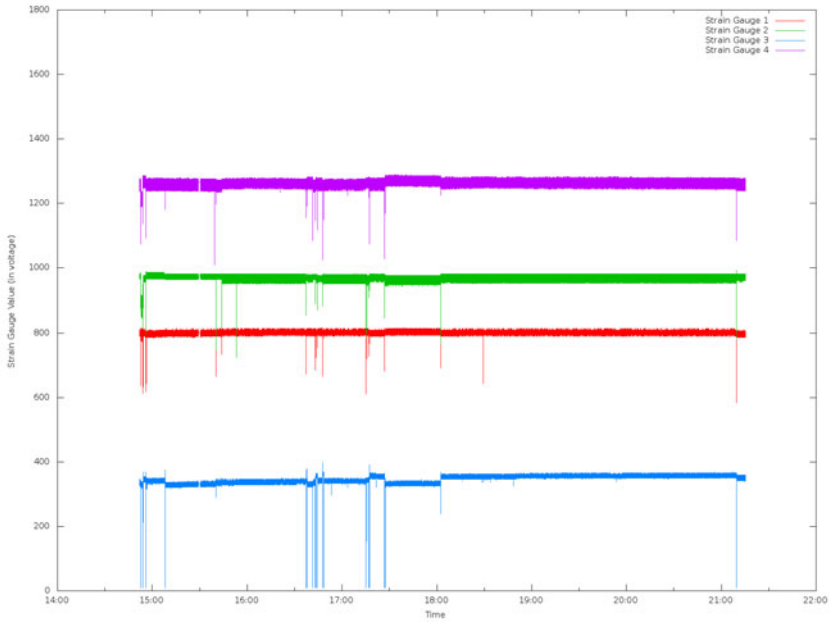
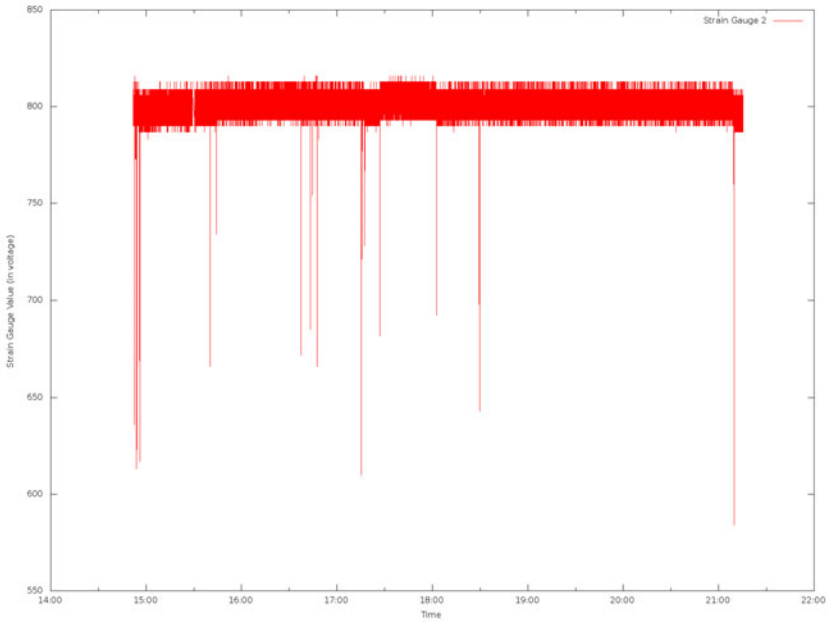

Fig. 4. CoCoS, a Java-based GUI for accessing the hallway data



(a) Data of all sensors.



(b) Detailed view on sensor 1.

Fig. 5. Data samples of four load sensors installed beneath one floor tile

The advantage of CoCoS is that it offers a global view of the whole network and all sensor data. This simplifies the development process tremendously, since new ideas can be implemented and evaluated easily by a centralized algorithm written in Java, and then later translated to a distributed one working directly on the hallway nodes.

5 Experimental Study

We recorded data of four sensors that are installed beneath one floor tile to show the correlation of the values, and to have a look into the data of one sensor in detail. The data was collected with 8 Hz (we can also take samples with 800 Hz), since it was recorded over several hours. One data sample is the value read at the ADC of the Atmel connected to the iSense node, and hence the already amplified strain gauge value in voltage. When there is no load produced, the sensor value stays constant. Whenever there is load detected, the value drops by a certain amount. The results for the four sensors are shown in Fig. 5(a).

The zero value of the sensors differs significantly—from around 400 up to approx. 1300. This is due to the self-construction of the sensors, since the zero value depends on the force the strain gauge is glued on the steel plate. Analogously, the amplitude is different from sensor to sensor. Issues arising from differences in zero value or amplitude can be overcome using appropriate distributed algorithms. The important observation is the high correlation in the data, which can be seen in the synchronous amplitude changes of the four sensors.

Fig. 5(b) shows the trace of one sensor in detail. The data is the raw output from the strain gauge, and thus basic noise can be seen even when there is no force put on the sensor. However, one can clearly distinct an amplitude from the noise.

6 Conclusion and Future Work

We presented a hallway monitoring system based on load and PIR sensors, which are connected to wireless sensor nodes. The sensor data is highly correlated, and enables the design of sophisticated distributed algorithms for target tracking or gait recognition. The nodes can collaborate to substitute the merely imprecise data of the load sensors. The inaccuracy of the sensors is outweighed by the extremely low cost—about 25 Euros per sensor, in contrast to more than 200 Euros for industrial solutions.

In addition, we also added actuators to the testbed. We installed 29 lights and speakers on the walls to enable the possibility of interaction between the sensor network and passing people. Both lights and speakers can be controlled by the sensor nodes beneath the floor, and can thus be directly integrated in distributed applications.

The whole design also deals with heterogeneity. We have 30 iSense sensor nodes that can communicate wirelessly. Each node is connected to a circuit board equipped with an Atmel Atmega48, responsible for amplifying and receiving the

load sensor data. This board is in turn wired to a circuit board at the walls, controlling the lights and speakers.

At this point, we finished the construction of the hallway. All sensors are installed, and the nodes are connected via USB to a backbone for reliable re-programming and data collection. We have also evaluated the output of the load sensors. In the next step, we will develop algorithms for more challenging tasks, such as accurate target tracking, identification of the number of people in the hallway, or the study of different gaits when the available sample rate of 800 Hz per load sensor is considered.

Acknowledgement. This work has been partially supported by the European Union under contract number ICT-2008-224460 (WISEBED). We thank Marcus Brandenburger, Peter Degenkolbe, Henning Hasemann, Winfried Hellmann, Björn Henriks, Roland Hieber, Peter Hoffmann, Hella-Franziska Hoffmann, Daniel Houschka, Rolf Houschka, Andreas König, Christiane Schmidt, Nils Schweer, Stephan Sigg, and Christian Singer for their assistance in the construction of the hallway.

References

1. Abbasi, A.A., Younis, M.: A survey on clustering algorithms for wireless sensor networks. *Computer Communications* 30(14-15), 2826–2841 (2007)
2. Adlesee, M., Jones, A., Livesey, F., Samaria, F.: The ORL active floor [sensor system]. *IEEE Personal Communications* 4(5), 35–41 (1997)
3. Akkaya, K., Younis, M.: A survey on routing protocols for wireless sensor networks. *Ad Hoc Networks* 3(3), 325–349 (2005)
4. Akyildiz, I.F., Su, W., Sankarasubramaniam, Y., Cayirci, E.: Wireless sensor networks: a survey. *Computer Networks* 38, 393–422 (2002)
5. Baumgartner, T., Fekete, S.P., Kröllner, A.: Hallway monitoring with sensor networks. In: *Proceedings of the 7th ACM Conference on Embedded Network Sensor Systems, SenSys 2009*, pp. 331–332. ACM, New York (2009)
6. Buschmann, C., Pfisterer, D.: iSense: A modular hardware and software platform for wireless sensor networks. Technical report, 6. Fachgespräch Drahtlose Sensor-netze der GI/ITG-Fachgruppe Kommunikation und Verteilte Systeme (2007)
7. Gambi, E., Spinsante, S.: Multi-camera localization and tracking for ambient assisted living applications. In: *AALIANCE Conference, Malaga, Spain (March 2010)*
8. Jin, A., Yin, B., Morren, G., Duric, H., Aarts, R.: Performance evaluation of a tri-axial accelerometry-based respiration monitoring for ambient assisted living. In: *Annual International Conference of the IEEE Engineering in Medicine and Biology Society, EMBC 2009*, pp. 5677–5680 (September 2009)
9. Johnson, D., Stack, T., Fish, R., Flickinger, D.M., Stoller, L., Ricci, R., Lepreau, J.: Mobile emulab: A robotic wireless and sensor network testbed. In: *INFOCOM. IEEE, Los Alamitos* (2006)
10. Kaddoura, Y., King, J., Helal, A.S.: Cost-precision tradeoffs in unencumbered floor-based indoor location tracking. In: *3rd International Conference on Smart Homes and Health Telematics, From smart homes to smart care: ICOST* (2005)

11. Mori, T., Sato, T., Asaki, K., Yoshimoto, Y., Kishimoto, Y.: One-room-type sensing system for recognition and accumulation of human behavior. In: IEEE/RSJ International Conference on Intelligent Robots and Systems (2000)
12. Mori, T., Suemaou, Y., Noguchi, H., Sato, T.: Multiple people tracking by integrating distributed floor pressure sensors and WID system. In: IEEE International Conference on Systems, Man and Cybernetics (2004)
13. Orr, R.J., Abowd, G.D.: The smart floor: a mechanism for natural user identification and tracking. In: Extended Abstracts on Human Factors in Computing Systems, CHI 2000, pp. 275–276. ACM, New York (2000)
14. Qian, G., Zhang, J., Kidané, A.: People identification using gait via floor pressure sensing and analysis. In: Roggen, D., Lombriser, C., Tröster, G., Kortuem, G., Havinga, P. (eds.) EuroSSC 2008. LNCS, vol. 5279, pp. 83–98. Springer, Heidelberg (2008)
15. Raychaudhuri, D., Ott, M., Secker, I.: Orbit radio grid tested for evaluation of next-generation wireless network protocols. In: Proceedings of the First International Conference on Testbeds and Research Infrastructures for the DEvelopment of NeTworks and COMmunities, TRIDENTCOM 2005, Washington, DC, USA, pp. 308–309. IEEE Computer Society Press, Los Alamitos (2005)
16. Seventh Framework Programme FP7 - Information and Communication Technologies. Wireless Sensor Networks Testbed Project (WISEBED), ongoing project since (June 2008), <http://www.wisebed.eu>
17. Sundararaman, B., Buy, U., Kshemkalyani, A.D.: Clock synchronization for wireless sensor networks: a survey. *Ad Hoc Networks* 3(3), 281–323 (2005)
18. Werner-Allen, G., Swieskowski, P., Welsh, M.: Motelab: a wireless sensor network testbed. In: Proceedings of the 4th International Symposium on Information Processing in Sensor Networks, IPSN 2005, USA, IEEE Computer Society Press, Los Alamitos (2005)
19. Yiu, C., Singh, S.: Tracking people in indoor environments. In: Okadome, T., Yamazaki, T., Makhtari, M. (eds.) ICOST. LNCS, vol. 4541, pp. 44–53. Springer, Heidelberg (2007)