

HalVA – Rule Analysis Framework for XTT2 Rules

Grzegorz J. Nalepa, Szymon Bobek, Antoni Ligęza, Krzysztof Kaczor

Institute of Automatics
AGH University of Science and Technology, Poland

RuleML
19-23 July 2011, Barcelona
<http://geist.agh.edu.pl>



Outline

- 1 Verification of Rule-Based Systems
- 2 HalVA
- 3 Verification Algorithms
- 4 Future Work

State of the art

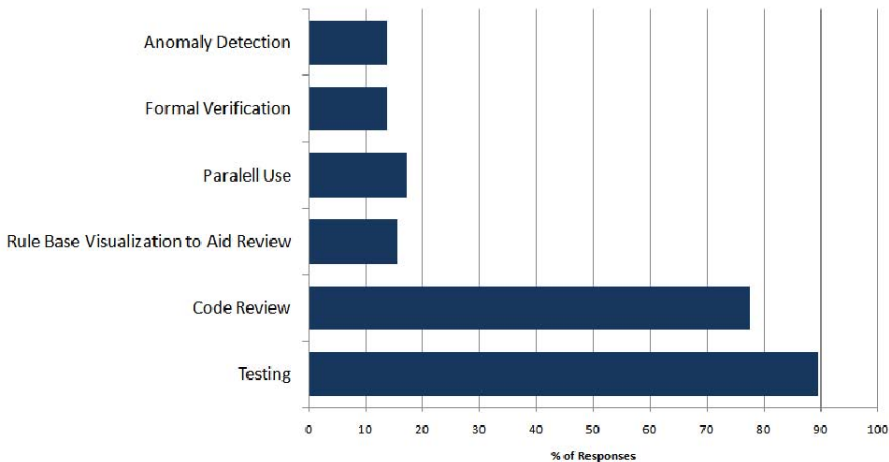

Figure: What can be verified (*Development and Verification of Rule Based Systems — A Survey of Developers*[6])

HalVA

Motivation

Provide tools for formalized knowledge base verification

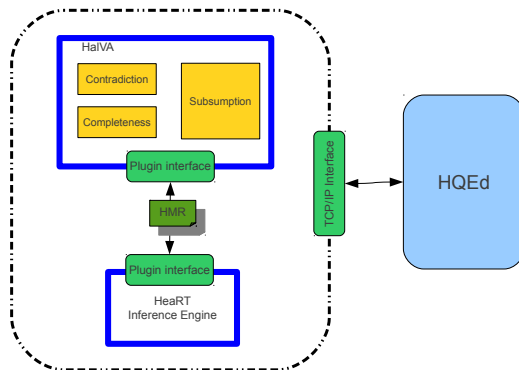

Figure: HeKatE Tools

What can be verified

- Inconsistency in a single rule
- Inconsistency between a pair of rules
- Subsumption within a single rule
- Subsumption between a pair of rules
- Completeness of a group of rules

XTT

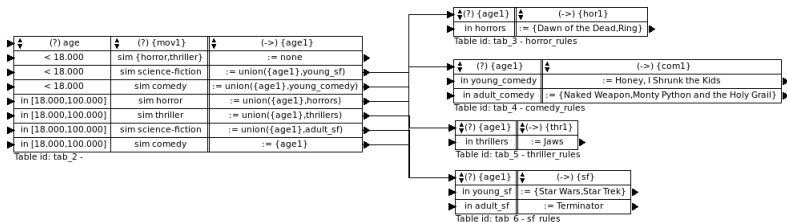

Figure: XTT Table

Rule in ALSV(FD) logic

IF $age < 18 \wedge movie_types \cap \{horror, thriller\} \neq \emptyset$
 THEN $age_filter := \emptyset$

Rule in HMR

$[age < 18, movie_types \text{ sim } [horror, thriller]]$
 $\implies [age_filter \text{ set } [none]].$

Local and Global Verification

Global Verification

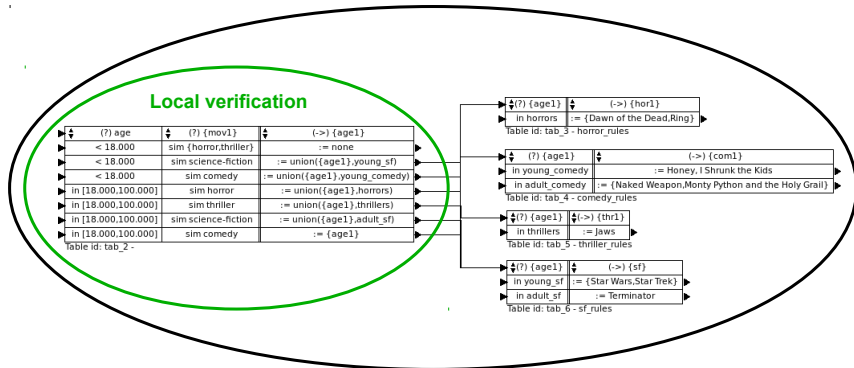

Figure: Local vs. Global verification

Related Work

DERIS2009: *Proposal of a graph-oriented approach to verification of XTT2 rule base* (XTT2 as a hyper graph)

How to verify?

Cartesian product of values of attributes

Combinatorial explosion - inefficient.

Combination of domain partitions

More efficient, but still domain dependant. Requires finite domains.

Future work

The new approach is based on analyzing logical dependencies between condition parts of rules, rather than on algebra of sets.

$$(A = V_1 \mapsto A = V_2) \Leftrightarrow V_1 = V_2$$

Partitioning domains

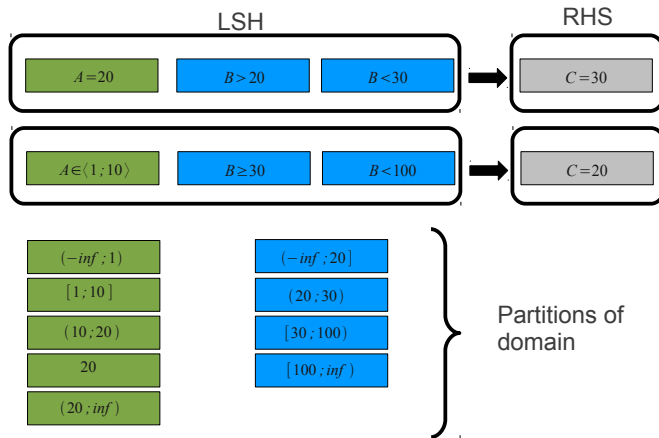

Figure: Partitioning domains

Inconsistency

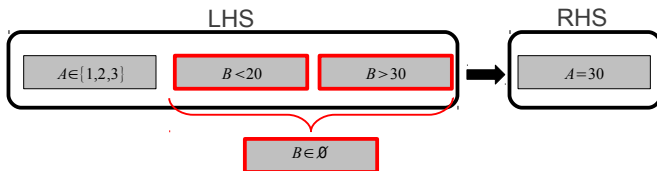

Figure: Inconsistency within a single rule

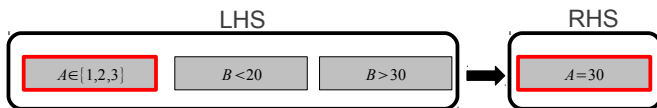

Figure: Inconsistency between LHS and RHS

Inconsistency

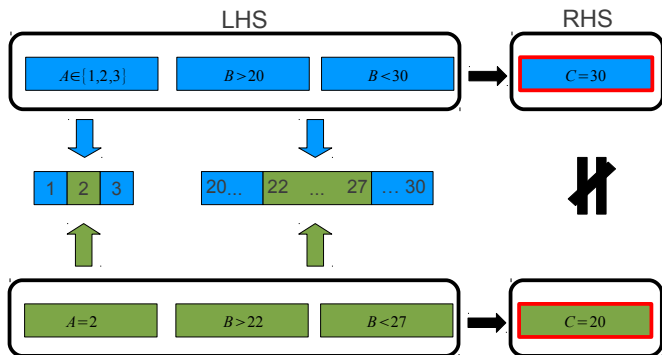

Figure: Inconsistency between a pair of rules

Subsumption

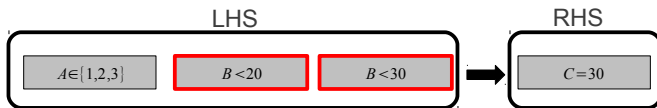

Figure: Subsumption within a single rule

Subsumption

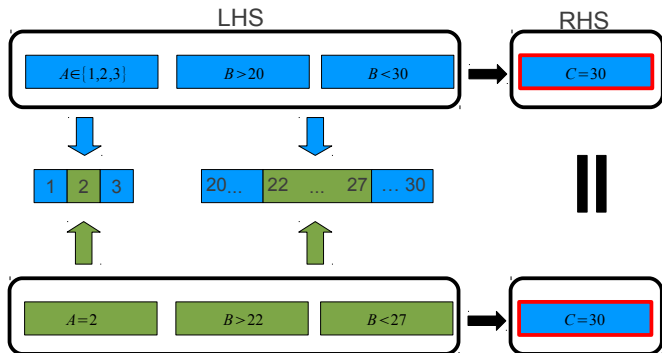

Figure: Subsumption of a pair of rules

Completeness of a group of rules

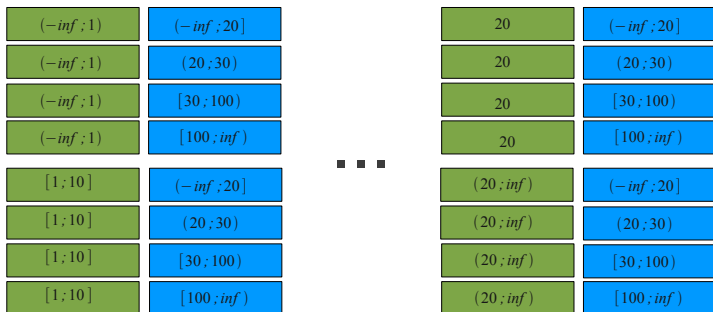

Figure: Cartesian product of partitions of domains

Completeness of a group of rules

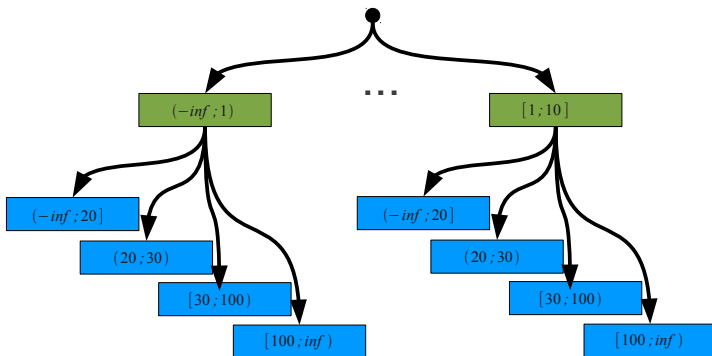

Figure: Tree of states

Completeness of a group of rules

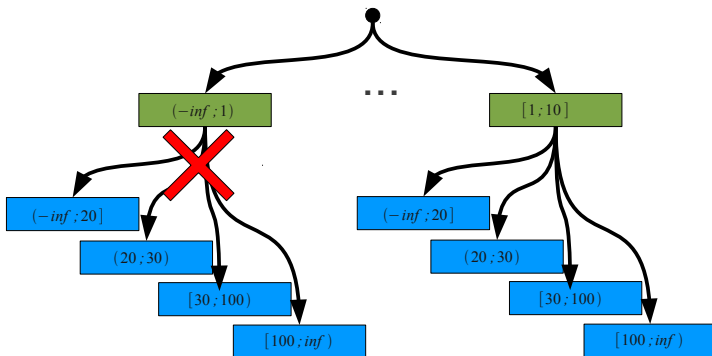
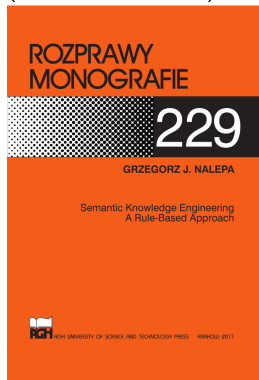

Figure: Tree of states

Conculsion

- Formalised knowledge base
- Custom rule representation
- Verification tools
 - ▶ Inconsistency
 - ▶ Subsumption
 - ▶ Completeness of a group of rules

Take a copy of the book
(outside the room):



Current Focus

BIMLOQ

Integrating BPMN with formalism provided by XTT.

<http://bimloq.ia.agh.edu.pl>



More information

KESE2011 *Proposal of a hierarchical approach to formal verification of BPMN models using Alvis and XTT2 methods*

¡Thank you for your attention!

¿Any questions?



www.geist.agh.edu.pl