

Handover Signaling for 3 Alternatives of Layer 3 Relay Node Implementation in LTE-advanced

Nurzal Effiyana Ghazali^{a*}, S. H. Syed Ariffin^a, N. Faisal^a, S. K. Syed Yusof^a

^aFaculty of Electrical Engineering, Universiti Teknologi Malaysia, 81310 UTM Johor Bahru

*Corresponding author:

Article history

Received: 8 March 2012
Received in revised form: 10 April 2012
Accepted: 18 July 2012

Graphical abstract

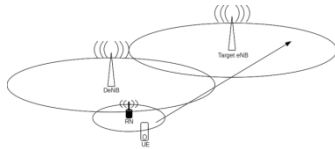

Abstract

Relaying is one of the technical specifications in LTE (Long Term Evolution)-Advanced. It is proposed to improve throughput at the cell edge and shadowing area. To enable relaying function in LTE-Advanced, current signaling should be modified because LTE does not support relaying technique. The enhancement work of LTE, proposed two architectures for RN (Relay Node) implementation which is called Architecture A and Architecture B. There are three alternatives in Architecture A and one alternative in Architecture B. This paper focused on the Architecture A. The control plane and user plane are discussed before the HO (Handover) signaling for each alternative in the Architecture A. L3 RN (Layer3 Relay Node) is considered in this architecture and work. The proposed signaling is based on HO scenario from a RN to a Target eNB (evolved NodeB) in a different cell.

Keywords: Architecture; Relaying, LTE (Long Term Evolution)-Advanced; HO (Handover); L3 RN (Layer 3 Relay Node)

© 2012 Penerbit UTM Press. All rights reserved.

1.0 INTRODUCTION

The 3GPP (3rd Generation Partnership Project) introduced LTE (Long Term Evolution) system as an evolution of cellular system. Towards aiming the ITU-R (International Telecommunication Union Radiocommunication) requirements, the 3GPP enhanced the LTE to become LTE-Advanced. The work for the enhancement is in 3GPP Release 9 whilst the work of the LTE-Advanced itself is in Release 10 and beyond [1].

The LTE-Advanced general requirement is it should meet or exceed IMT (International Mobile Telecommunication)-Advanced requirement which is stated as “enhanced peak data rates to support advanced services and applications (100 Mbps for high mobility and 1 Gbps for low mobility were established as targets for research)” [2]. LTE-Advanced shall be backward compatible with LTE (Release 8) so the enhancement work should be based on LTE. The technical requirements of the LTE-Advanced are it should support wider BW (bandwidth), implements MIMO (Multiple Input Multiple Output) techniques, support CoMP (Coordinated Multipoint Transmission and Reception) and support relaying functionality [1, 2, 3].

RN (Relay Node) can be divided into two categories with three functionalities [4]. The first category is transparent RN which supports L1 (Layer 1) and L2 (Layer 2) functions of RN only. The transparent RN does not have its own cell identity and it is transparent to the UE (User Equipment). The DeNB (Donor

eNB) transmits the control information to the UE and the RN relays the data to the UE. The eNB that the RN attached is known as DeNB. The second type of RN is non-transparent. This type of RN supports L2 and L3 (Layer 3) RN. Non-transparent RN has its own cell identity and it control its own cell. UE knows the L3 RN as Release 8 eNB [5].

L1 RN also known as a repeater [3, 4, 5, 6], carries out amplifying and forwarding processes. It gives low delay but it will amplify inter-cell interference and noise together with the desired signal which causes deterioration of SINR (Signal to Interference plus Noise Ratio) and limits the throughput enhancement [7]. L2 and L3 RN carry out decoding and forwarding processes thus it implies additional delay but provides improvement in SINR [6, 7]. The difference between L2 and L3 RN is L3 RN has self-backhauling functions [6] which make this type of RN can act as Release 8 eNB.

HO is a process of changing current associated radio with a new radio access to gain access for the ongoing service. LTE-Advanced supports network-controlled UE-assisted hard HO only. The hard HO also known as make-before-break HO means the previously associated radio will be terminated before the new radio access is established. Therefore, this type of HO introduces interruption time in the user plane.

This paper gives the details of HO signaling in the control plane and user plane aspects to give a clear picture for the HO process in LTE-Advanced based on architecture with three alternatives. The comparison of the three alternatives will be discussed in detail. In this work, the signaling is based on the

implementation of L3 RN because this is a candidate for LTE-Advanced [7, 8].

The remainder of this paper is organized as follows: Section II describes the existing architecture for each alternative to implement L3 RN. Section III describes the proposed signaling for each type of alternative. Finally, section IV concludes this paper.

2.0 RELAY ARCHITECTURE IN LTE-ADVANCED

3GPP introduced two types of relay architectures in [8] which are called Architecture A and Architecture B. There are three alternatives exist in Architecture A and only one alternative in Architecture B. Only Architecture A will be discussed in this paper. The Alt. 1 (Alternative 1) also known as Full L3-relay and it is transparent to the DeNB. Proxy S1/X2 is another name for the Alt. 2 (Alternative 2) whilst Alt. 3 (Alternative 3) has identity of RN bearers terminated in DeNB. Figure 1 shows relationship among the alternatives in Architecture A.

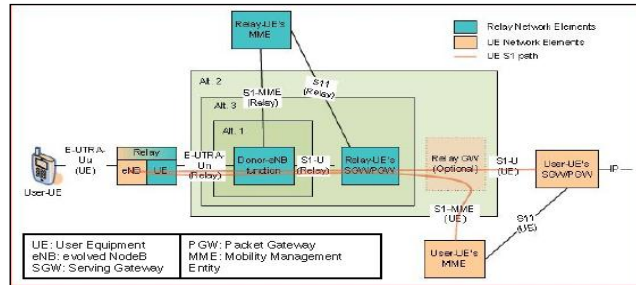

Figure 1 Relationship among alternatives in Architecture A

The S1-MME and X2 interfaces are unmodified for all alternatives. The difference is only in Alt. 2 where both interfaces are terminated in the DeNB whilst in the others they are terminated at the RN after being tunneled through a bearer on the Un interface. On the other hand, this is the reason Alt. 2 is known as Proxy S1/X2. The difference between Alt. 1 and 3 is by integrating the SGW/PGW (Serving Gateway/ Packet Gateway) functionality for the RN into the DeNB thus makes it known as RN bearers terminate in DeNB.

2.1 User Plane

User plane for all alternatives in Architecture A is discussed in this subchapter. Figure 2 and 3 show user plane protocol stack for Alt. 1 and 3, respectively.

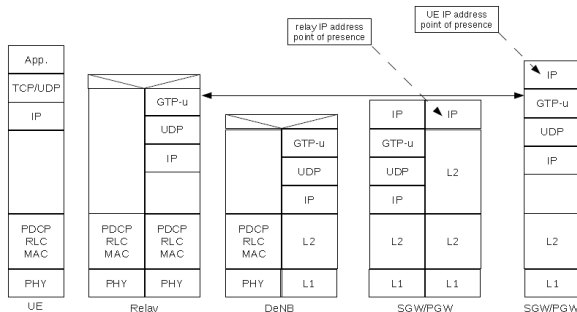

Figure 2 Alt. 1 user plane protocol stack

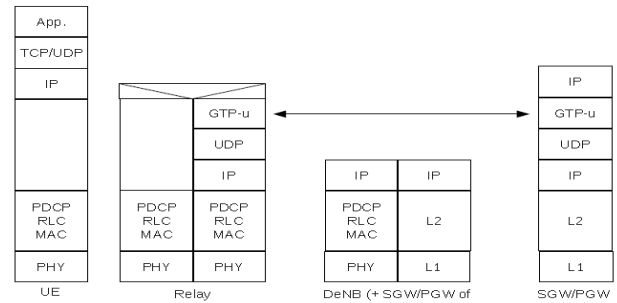

Figure 3 Alt. 3 user plane protocol stack

Alt. 1 is also called as Full L3 Relay because it does not have any special enhancement like the others. Different from Alt. 1, in Alt. 3, the DeNB function is combined with the SGW/PGW serving the RN function as shown in Figure 3. This optimized routing path as packets do not have to traverse via the second SGW/PGW. The packet delivery steps have been drawn in Figure 4.

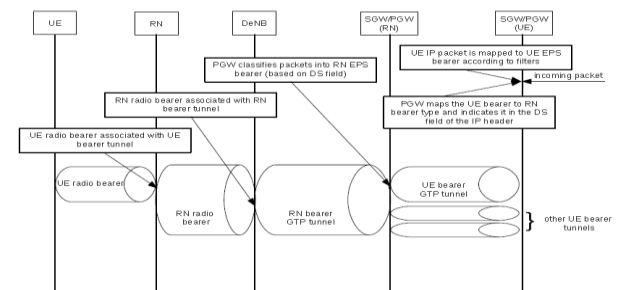

Figure 4 Packet delivery steps for Alt. 1

The packet delivery starts from the incoming packet at the SGW/PGW serving UE. The SGW/PGW for the UE encapsulated the packet into the respective GTP (GPRS Tunneling Protocol) tunnel. The SGW/PGW serving the RN plays a role of deciding on the UE bearer to RN bearer mapping. The RN bearer type may be indicated as a DiffServ (Differentiated Services) codepoint in the DS field of the IP header of the GTP IP packet sent by the SGW/PGW serving UE [8]. When the SGW/PGW serving RN receives the GTP (GPRS Tunneling Protocol) tunnel, it encapsulates the packet into the second GTP tunnel corresponds to the RN bearer. Then, the DeNB associates the tunnel with the corresponding RN radio bearer and sends the packet to the RN over radio interface. The RN associates the received packet with the UE radio bearer and sends to the UE. In Alt. 3, the procedure is same as well as no RN bearer GTP tunnel as depicted in Figure 5.

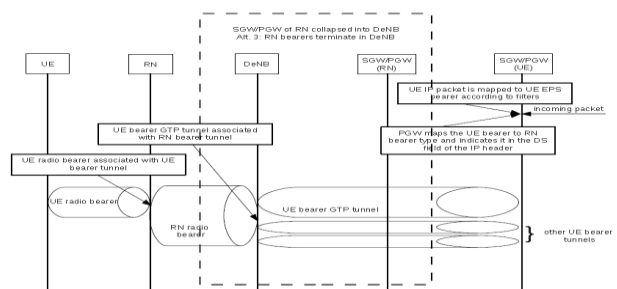

Figure 5 Packet delivery steps for Alt. 3

Figure 6 depicts the user plane protocol stack for Alt. 2 and Figure 7 shows the packet delivery steps.

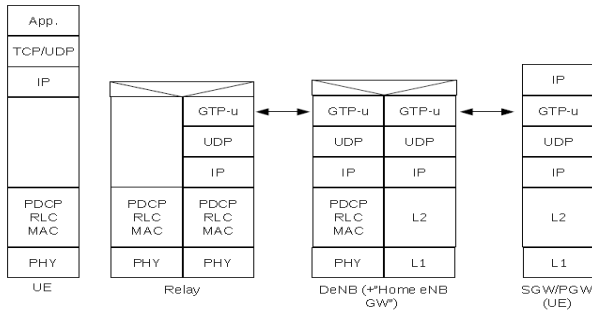

Figure 6 User plane protocol stack for Alt. 2

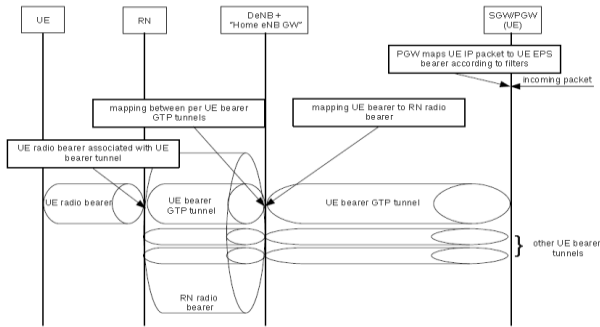

Figure 7 Packet delivery steps for Alt. 2

There is a great difference in Alt. 2 where it has “home eNB GW” function in DeNB which gives function of Proxy S1/X2. In this alternative, there is UE bearer GTP tunnel from SGW/PGW serving UE to the RN. The DeNB + “home eNB GW” switched the first tunnel which is received from SGW/PGW serving UE to the second tunnel which is sent to the RN. It is one-to-one mapping process. Then the RN associates the received packet with the corresponding UE bearer based on the per UE bearer GTP tunnel.

2.2 Control Plane

The control plane protocol stacks for Alt. 1 and 3 are shown in Figure 8.

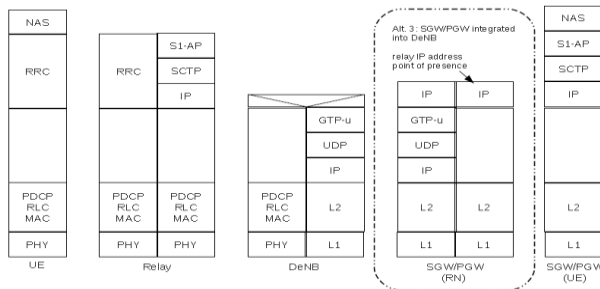

Figure 8 Alt. 1 and 3 control plane protocol stack

As depicted in Figure 8, S1-AP protocol is terminated between RN and MME (Mobility Management Entity) serving the UE. The signaling message of S1 is delivered between MME

serving the UE and RN via DeNB and SGW/PGW serving the RN. It goes transparently where the signaling messages are mapped on the user plane EPS (Evolved Packet System) bearer of the RN. Figure 9 shows the S1 signaling for Alt. 1 and 3.

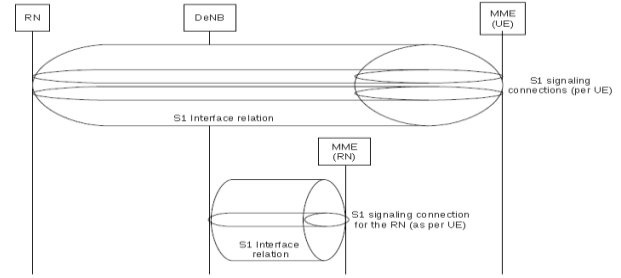

Figure 9 S1 interface relations and signaling connections of Alt. 1 and 3

The RN needs to maintain S1 interface relation for each UE between it and MME serving the UE. The DeNB also has to maintain its S1 interface relation. In this case, the RN looks as an UE to the DeNB and the S1 interface relation is between DeNB and MME serving the RN, as depicted in Figure 9.

In Alt. 2, S1 signaling between MME serving the UE and RN does not go transparently to the DeNB because the DeNB has S1-AP protocol stack, as depicted in Figure 10.

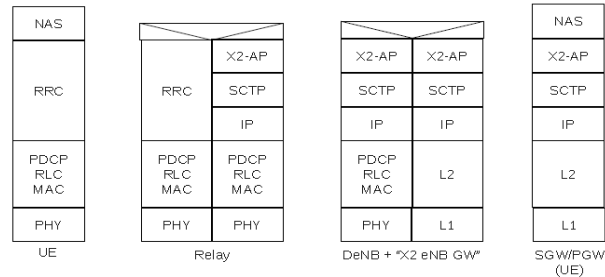

Figure 10 Alt. 2 control plane protocol stack

There will be two S1 interface signaling messages which go between RN and DeNB and between DeNB and MME serving the UE. On the receiving of the S1-AP messages, the DeNB translates the UE IDs between the two interfaces then sends the message. The other part of the message is unchanged. This process corresponds to a S1-AP proxy mechanism thus it is transparent to the RN and MME serving the UE. Figure 11 shows the S1 interface relations and signaling connections of Alt. 2.

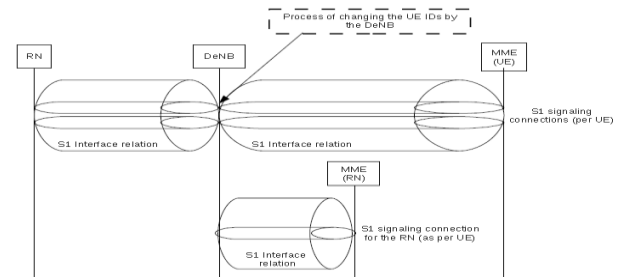

Figure 11 S1 interface relations and signaling connections of Alt. 2

Similar to the previous case, DeNB has to maintain the S1 signaling with the MME serving the RN. The implementation of X2-AP is the same as S1-AP, where the S1-AP stack is replaced by X2-AP.

3.0 HO SIGNALING IN LTE

LTE HO can be divided into three phases which are preparation, execution and completion phases. HO preparation phase starts when the source eNB issues HO Request message to the target eNB. During the preparation phase, HO decision is made by the source eNB based on the measurement report from the UE. The target eNB prepares HO by sending relevant information to the UE through source eNB as part of the HO Request Ack command.

U-plane (User plane) tunnels can be established between source eNB and target eNB upon receiving HO Request message. There should be one tunnel for DL data forwarding and one for UL data forwarding for each E-RAB (EUTRAN Radio Access Bearer).

The second phase of the HO is the execution phase which starts after HO Command message until the target eNB receives RRC Connection Reconfiguration Complete message. During this phase, user data is forwarded from the source eNB to the target eNB as long as the source eNB receives packet from the EPC (Evolved Packet Core) or its buffer is not empty.

During the last phase, the target eNB sends a Path Switch Request message to MME to inform that the UE has changed cell. Then, the MME sends a U-plane Update Request message to the Serving GW. One or more end marker message is sent by the Serving GW to the source eNB asks to release any U-plane in the old path to the target eNB. The target eNB informs the successfulness of the HO to the source eNB by sending UE Context Release and the source eNB can release radio and C-plane (Control plane) resources. The U-plane handling Path Switch Request to inform that the UE has gained access and Serving GW switches the path from the source eNB to the target eNB. Any ongoing data forwarding may continue. The HO signaling is shown in Figure 12.

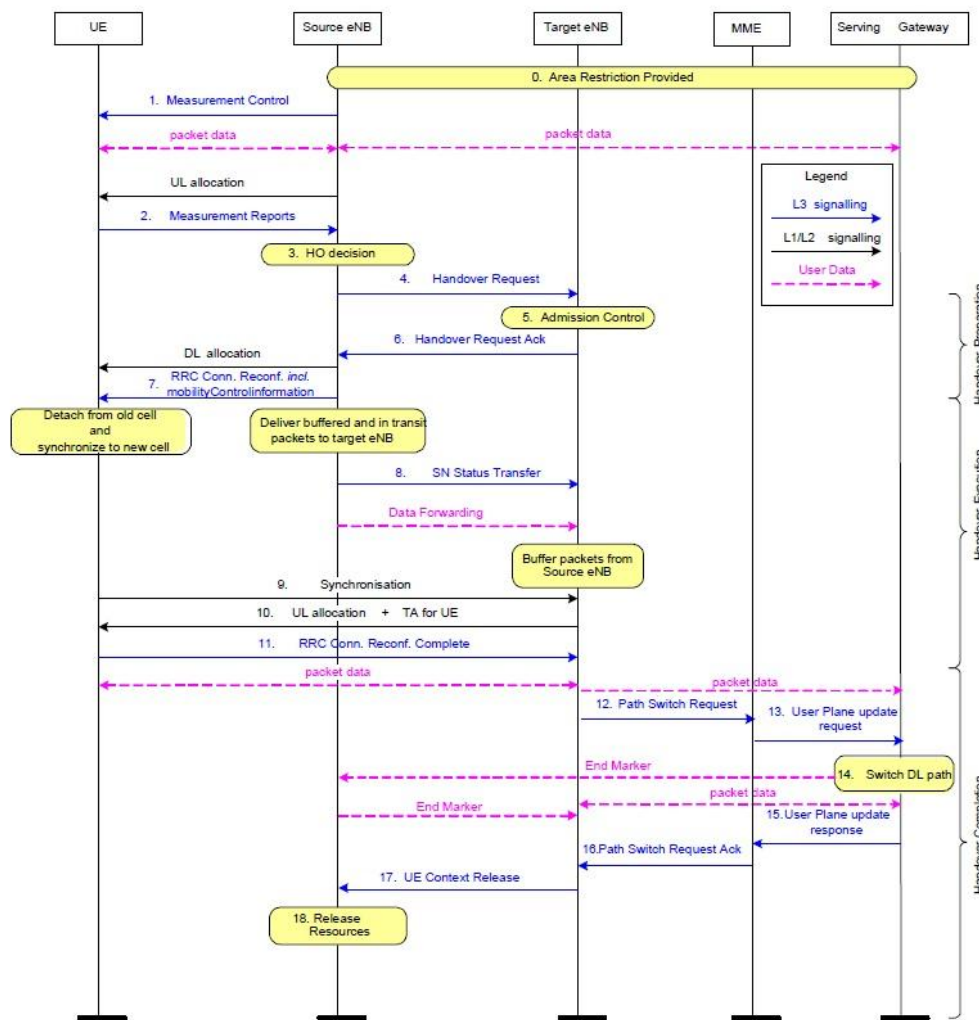

Figure 12 HO signaling for LTE [9]

3.1 HO in LTE-Advanced

HO process of an UE from a source eNB to a target eNB can be based on S1 or X2 reference point. In this discussion, MME is

considered unchanged. Two procedures can be defined depending on whether the Serving GW is unchanged or relocated. The onward discussion is focused on X2-based handover without Serving GW relocation.

In this paper, X2 HO for Alt. 1, Alt. 2 and Alt. 3 are discussed based on a scenario depicted by Figure 13.

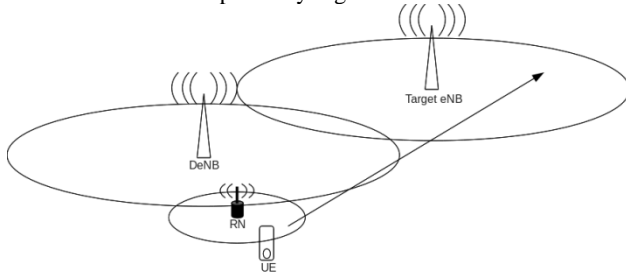

Figure 13 X2 HO scenario

In the scenario there is one DeNB, one Target eNB, one RN and one UE. eNB in the left cell is named as DeNB because it has RN under its coverage whilst the other one eNB is alone, that is why it is named as Target eNB. Consider the UE moves from the cell under RN coverage towards the cell under Target

eNB coverage. The signaling for the Alt. 1 and Alt. 3 are shown in Figure 14. For the HO process, six elements are needed which are UE, RN, DeNB, Target eNB, SGW/PGW serving RN and SGW/PGW serving UE. MME serving UE is needed during the path switching for data forwarding.

The RN makes HO decision based on the measurement report that it gets from the UE and it will select a target cell. Then, it sends HO Req message to the target eNB over an EPS data bearer that is provided by the DeNB and the SGW/PGW serving RN. In this case, the HO process is transparent to the DeNB because this type of DeNB does not have X2-AP protocol. When the Target eNB receives the message it will reply with HO Req Ack messages via the same bearer. Even though the process is transparent to the DeNB, the Target eNB looks the request as it comes from the DeNB, not from the RN. After the completion of the X2 signaling, forwarding tunnel is established from the RN over EPS bearer(s) via the DeNB and then the SGW/PGW serving the RN and further on the target eNB [8].

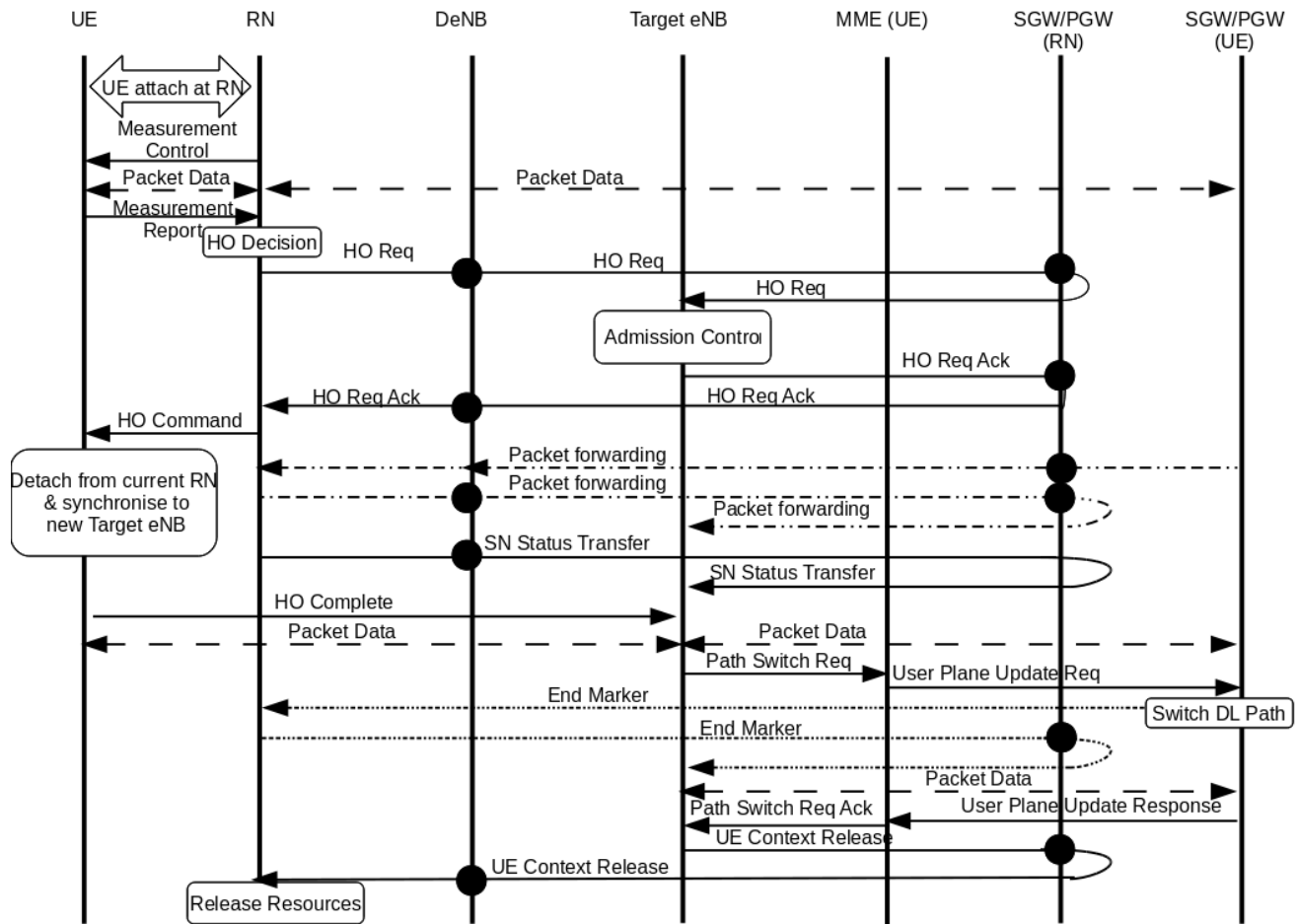

Figure 14 X2 HO signaling for Alt. 1 and Alt. 3

A great difference occurs in the implementation of Alt. 2 especially in its DeNB. The DeNB has a function of “home eNB GW”. Compared with Alt. 1 and Alt. 3, the HO process needs only five elements which are UE, RN, DeNB+“X2 home eNB GW”, Target eNB and SGW/PGW serving UE. The MME serving UE is needed for the path switching only. The signaling is shown in Figure 15. The difference between Figure 14 and

Figure 15 is in Figure 15, there is no SGW/PGW serving RN because the function is in the DeNB+“X2 home eNB GW”. Thus, the HO Req. message, HO Req. Ack. Message, packet forwarding, SN Status Transfer message and UE Context Release can be sent directly from the RN to the target eNB via DeNB+“X2 home eNB GW”.

Alt. 1 and Alt. 3 signaling shown in Figure 14 can be used for the scenario where the UE making a HO to another RN under the same DeNB or different DeNB [8]. In the case of Alt. 2 signaling, the same signaling can be used when the UE making a HO from the RN to the DeNB.

In [10], HO framework based on centralized relaying and decentralized relaying was proposed. The centralized relaying is proposed for the L1 and L2 RN whilst decentralized relaying for L2 and L3 RN. In this work the signaling can be considered as decentralized relaying technique because the architecture involved is for L3 RN. In [10], the HO decision is done by the

DeNB, but in this work it is done by the RN itself. The HO Req. message is sent to the Target eNB via DeNB. The message will be transparent in Alt. 1 and Alt. 3 but not in Alt. 2 where the DeNB reads the target cell ID from the message before sending it to the Target eNB.

The advantage of having HO decision at the RN is no redundant measurement control message, measurement report message and HO command messages. In traditional signaling these messages traverse among 3 elements which are UE, RN and DeNB but in this proposed work they traverse between 2 elements only which is between UE and RN.

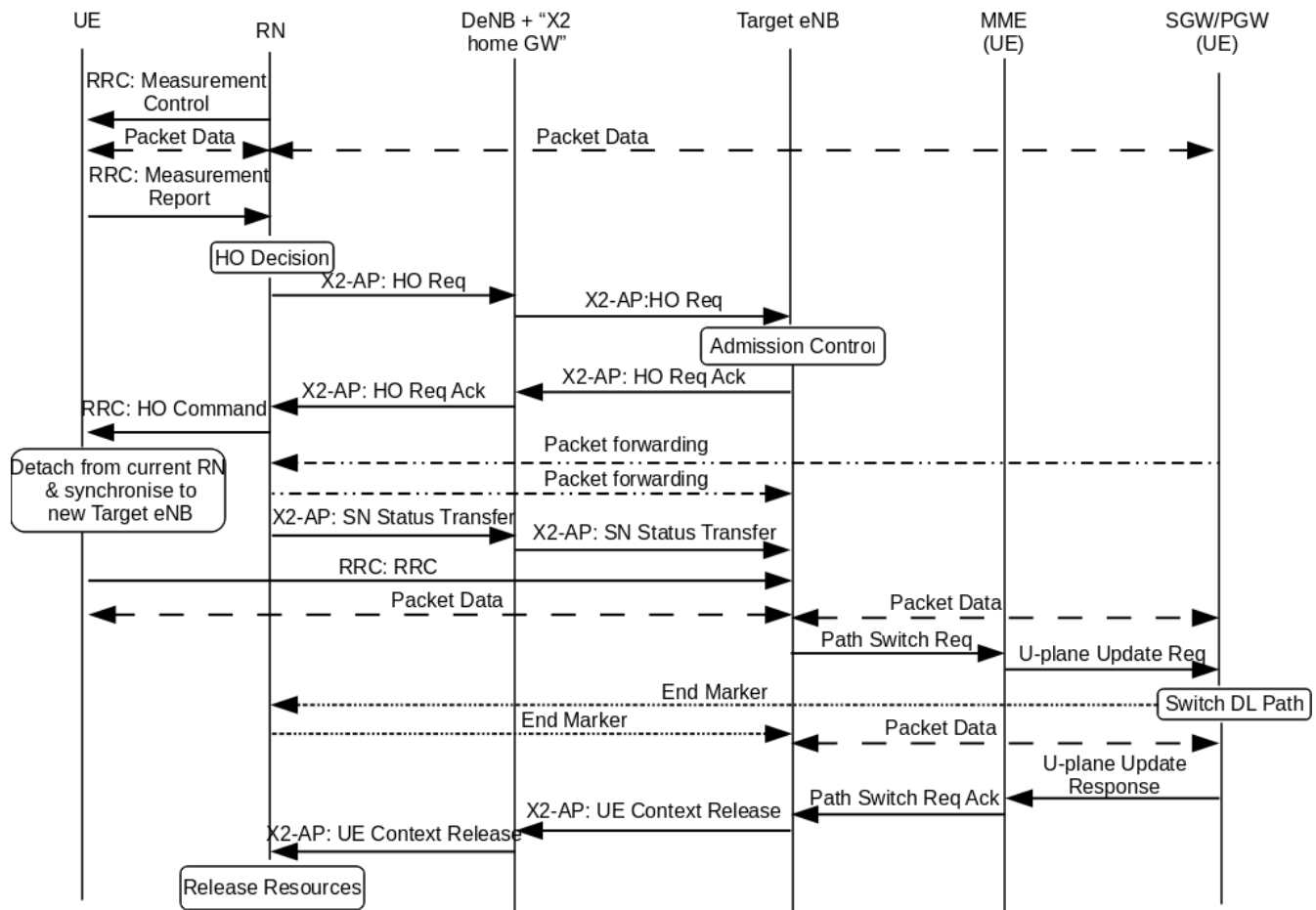

Figure 15 X2 HO signaling for Alt. 2

4.0 CONCLUSION

RN is a new element in LTE which is introduced in 3GPP Release 9, 2010. The implementation of it is still in research. Therefore, the framework of its implementation is important. This work extended the discussion of HO signaling in the 3GPP Technical Report to give a clear view how the RN is going to be implemented in LTE-Advanced.

There are two candidate architectures for the implementation which are Architecture A and B. Architecture A has three alternatives, Alt. 1, Alt. 2 and Alt. 3. However Alt. 2 is a candidate of LTE-Advanced. The HO signaling proposed in this work is based on the three alternatives in Architecture A. The signaling varies based on the alternatives but Alt. 1 and Alt. 3 are quite similar. The advantage of Alt. 2 is the signaling is reduced as well as the number of the elements.

In this work, HO decision is proposed to be done by the RN to reduce the redundant messages traverse among UE, RN and DeNB. In future, the performance of these signaling should be done to obtain the quantitative value.

References

- [1] Takehiro Nakamura. 2009. Proposal for Candidate Radio Interface Technologies for IMT-Advanced Based on LTE Release 10 and Beyond (LTE-Advanced). ITU-R WP 5D 3rd Workshop on IMT-Advanced, October.
- [2] Tommi Koivisto. 2008. LTE-Advanced research in 3GPP. Nokia GIGA Seminar, Dec.
- [3] David Martin-Sacristan, Jose F. Monserrat, Jorge Cabrejas-Penuelas, Danial Calabuig, Salvador Garrigas and Narcis Cardona. 2009. On the Way towards Fourth-Generation Mobile: 3GPP LTE and LTE-Advanced. EURASIP Journal on Wireless Communications and Networking. 2009.

- [4] Jung Je Son. 2009. New Feature for IMT-Advanced: Relay. 2009 Training Workshop on 4G Mobile (IMT-Advanced) System and Applications, November.
- [5] Amit Kumar. 2010. LTE-Advanced: The Roadmap to 4G Mobile Wireless Networks. *Global Journal of Computer Science and Technology*. 10(4): 50–53.
- [6] Erik Dahlman, Ylva Jading, Stefan Parkvall and Hideshi Murai. 2009. 3G Radio Access Evolution-HSPA and LTE for Mobile Broadband. *IEICE Trans. Commun.* 5: 1432–1440.
- [7] Satoshi Nagata, Yuan Yan, Xinying Gao, Anxin Li, Hidetoshi Kayama, Tetsushi Abe and Takehiro Nakamura. 2011. Investigation on System Performance of L1/L3 Relays in LTE-Advanced Downlink. *IEEE 73rd Vehicular Technology Conference*, May.
- [8] 3GPP TR 36.806. 2010. Evolved Universal Terrestrial Radio Access (E-UTRA); Relay architectures for E-UTRA (LTE-ADVANCED) (Release 9). v.9.0.0, March.
- [9] 3GPP TS 36.300. 2010. Evolved Universal Terrestrial Radio Access (E-UTRA) and Evolved Universal Terrestrial Radio Access Network (E-UTRAN); Overall Description; Stage 2 (Release 8). v.8.12.0, March
- [10] Oumer Teyeb, Vinh Van Phan, Bernhard Raaf and Simone Redana. 2009. Handover Framework for Relay Enhanced LTE Networks,” *IEEE Workshop on Communications*.