



LUND UNIVERSITY

HCCI Closed-Loop Combustion Control Using Fast Thermal Management

Haraldsson, Göran; Tunestål, Per; Johansson, Bengt; Hyvönen, Jari

Published in:
SAE Transactions, Journal of Engines

2004

[Link to publication](#)

Citation for published version (APA):

Haraldsson, G., Tunestål, P., Johansson, B., & Hyvönen, J. (2004). HCCI Closed-Loop Combustion Control Using Fast Thermal Management. *SAE Transactions, Journal of Engines*, 113(3), 599-610.
<http://www.ingentaconnect.com/content/docdel/art1045772222>

Total number of authors:
4

General rights

Unless other specific re-use rights are stated the following general rights apply:
Copyright and moral rights for the publications made accessible in the public portal are retained by the authors and/or other copyright owners and it is a condition of accessing publications that users recognise and abide by the legal requirements associated with these rights.

- Users may download and print one copy of any publication from the public portal for the purpose of private study or research.
- You may not further distribute the material or use it for any profit-making activity or commercial gain
- You may freely distribute the URL identifying the publication in the public portal

Read more about Creative commons licenses: <https://creativecommons.org/licenses/>

Take down policy

If you believe that this document breaches copyright please contact us providing details, and we will remove access to the work immediately and investigate your claim.

LUND UNIVERSITY

PO Box 117
221 00 Lund
+46 46-222 00 00

HCCI Closed-Loop Combustion Control Using Fast Thermal Management

Göran Haraldsson, Per Tunestål and Bengt Johansson

Division of Combustion Engines, Lund Institute of Technology

Jari Hyvönen

Fiat-GM Powertrain Sweden

Copyright © 2004 SAE International

ABSTRACT

This study applies Closed-Loop Combustion Control (CLCC) using Fast Thermal Management (FTM) on a multi cylinder Variable Compression Ratio (VCR) engine together with load control, to achieve a favorable combustion phasing and load at all times. Step changes of set points for combustion phasing, Compression Ratio (CR), and load together with ramps of engine speed with either constant load, i.e. load control enabled, or constant fuel amount are investigated. Performances of the controllers are investigated by running the engine and comparing the result with CLCC using VCR, which was used in an earlier test. Commercial RON/MON 92/82 gasoline, which corresponds to US regular, is used in the transient tests. Limitations to the speed ramps are further examined and it is found that choice of fuel and its low temperature reaction properties has large impact on how the CLCC perform. The CLCC using FTM handles step changes in combustion phasing fairly well and has a time constant of 8 engine cycles, which is 57% faster than the CLCC using VCR even though it suffers from the large air volume between throttle and engine inlet.

INTRODUCTION

The Homogeneous Charge Compression Ignition (HCCI) engine can be understood as a hybrid between the Spark Ignition (SI) and Compression Ignition (CI) engines. In the SI engine, fuel and air are mixed homogeneously before combustion initiation. The charge is then compressed and ignited by a spark plug at the most convenient time for the combustion process. Load control of an SI engine is taken care of by adjusting the amount of mixed air and fuel entering the cylinder.

In the CI engine, air is compressed to a higher pressure than in the SI engine, and fuel is injected at high pressure into the hot compressed air and auto-ignition occurs. By adjusting the amount of injected fuel, the load is controlled and hence no throttling is necessary. HCCI

engines use a premixed air and fuel mixture like the SI engine and compress this mixture to auto-ignition like the CI engine. There are various parameters to take into account in order to achieve proper HCCI combustion. Temperature and pressure in the cylinder at the end of the compression stroke, auto ignition properties of the fuel and residual gas fraction all affect the HCCI ignition process. The temperature of the charge has to be higher at the end of the compression phase, compared to the SI engine, in order to cause auto ignition with conventional SI engine fuels.

The first presented results of HCCI engines were performed on 2-stroke engines [1-2]. The primary purpose of using HCCI combustion in 2-stroke engines is to reduce the HC emissions at part load operation, and to decrease fuel consumption by stabilizing the combustion of diluted mixtures. In four-stroke engines, auto ignition can be achieved through a high Compression Ratio (CR), preheating of the inlet air or use of retained residuals [3-9]. In two-strokes, residual gas is always present because of incomplete scavenging, and therefore no preheating is necessary. For 4-stroke engines, HCCI has the potential of combining the desirable features of SI (low NO_x and particulates) with the desirable features of CI (high efficiency through low pumping losses and high CR).

The low combustion temperature and higher CR with HCCI combustion leads to higher HC and CO emissions than from SI and CI engines [10]. The low exhaust gas temperature is also a problem for the catalyst, since a fairly high temperature is needed to start the oxidation. Another drawback is the very high heat release rate, which leads to high maximum pressures and noise levels. To avoid too fast combustion, a diluent must be used. The diluent can be any combination of air, residual gas and Exhaust Gas Recirculation (EGR). In four-strokes, EGR is used both as a diluent to slow down combustion and as bulk to control the temperature of the intake mixture. Since the onset of combustion depends on temperature, pressure, and mixture formation in each cylinder, controlling the combustion process is a

challenge. One way to monitor the onset of combustion is to measure the cylinder pressure in each cylinder and calculate the accumulated heat release online. The Crank Angle of 50% heat release (CA50) then serves as a quantitative measure of the combustion phasing [11]. Open-loop combustion phasing using Variable Compression Ratio (VCR) is shown in earlier papers [10,12] to result in a large operating range for HCCI, and CR as high as 21:1 is effective [14,15] for this engine. Closed-Loop Combustion Control (CLCC) using VCR is shown to have potential to handle step changes in a matter of engine cycles [16]. Single cylinder transient Closed-Loop HCCI control using variable valve timing with quite fast response is shown in [17]. Both the variable valve timing and VCR system is rather expensive. It is therefore of interest to examine other means for CLCC.

Thermal management is shown by Stockinger et al. [5] during steady state operation. A similar thermal management system is suggested by Yang et al. [18] on a single cylinder HCCI engine. The engine of the present study has VCR and inlet air temperature as a means to phase the combustion. However CR is not used for combustion control here. The CLCC using FTM adjusts the inlet air temperature by using a source of cold ambient air, and a source of hot recovery-heated air, where a mean CA50 for all cylinders is used as feedback for control.

In this study transient performance of a CLCC using the FTM system is investigated experimentally on a multi cylinder engine using an exhaust heat recovery system [14-15]. The performance of the controllers is then compared to the performance of the CLCC using VCR [16]. The control system is explained mainly where there is new and improved functionality compared to the previous test [16].

EXPERIMENTAL APPARATUS

THE ENGINE

The engine used is a five-cylinder 1.6L Saab Variable Compression (SVC) prototype engine. This engine is the basis for a downsized highly boosted SI engine concept [20]. The VCR mechanism of the engine can be seen in Figure 1 and its specifications are given in Table 1.

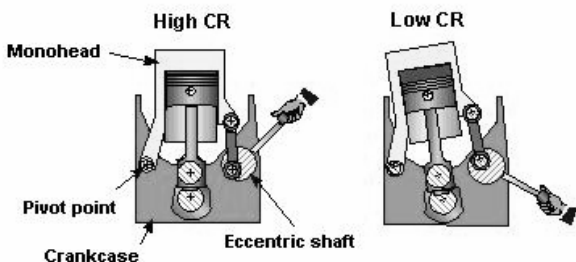

Figure 1 Saab Variable Compression (SVC) engine [20].

The geometric CR can be varied continuously between 9:1 and 21:1 by tilting the upper part of the engine up to approximately four degrees by rotating the eccentric shaft. The engine is run naturally aspirated during the tests presented in this paper.

Table 1 Geometric specifications of the engine.

Displacement	1598 cm ³ (320 cm ³ /cyl)
Number of cylinders	5
Compression Ratio	Adjustable 9–21:1
Bore x Stroke	68mm x 88mm
Exhaust valve open	45°BBDC at 0.15mm lift
Exhaust valve close	7°ATDC at 0.15mm lift
Inlet valve open	7°BTDC at 0.15mm lift
Inlet valve close	34°ABDC at 0.15mm lift
Combustion chamber	Pent roof/four valves DOHC

The cylinder pressures are monitored with water-cooled cylinder pressure sensors from Kistler, model 6043A fitted in custom made holes in the cylinder head, one for each cylinder. Due to the high CR, which does not leave any room for the original spark plugs, the spark plugs are removed and blinds are fitted in the holes.

FAST THERMAL MANAGEMENT SYSTEM

The FTM system consists of an electrical inlet air pre-heater of 11 kW used for startup, a heat exchanger to recover heat from the exhaust, an oxidizing main catalyst from a Saab 9-5 3.0 TiD V6 diesel and two standard throttle valves for air mixing from a Saab 9-3. A schematic of the FTM system is shown in Figure 2

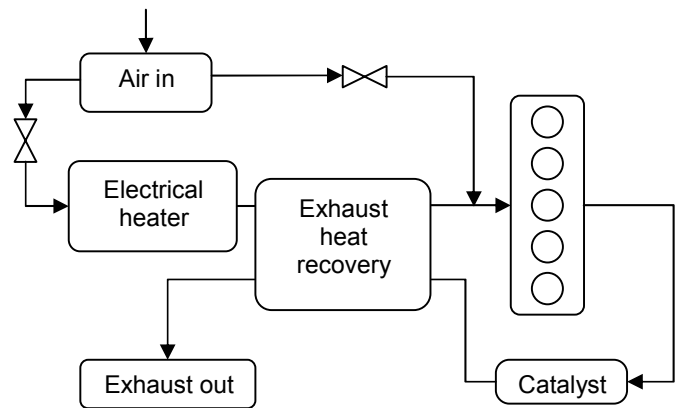

Figure 2 Schematic of the FTM system.

The left throttle controls the amount of hot inlet air and the right throttle controls the amount of cold ambient air to the engine. The cold air flow is mixed with the hot air flow after the heat exchanger. At a position 500mm downstream of the mixing a thin thermocouple type K with a diameter of 0.5mm is fitted to be able to follow the temperature transients during control. A picture of the FTM system is shown in Figure 3.

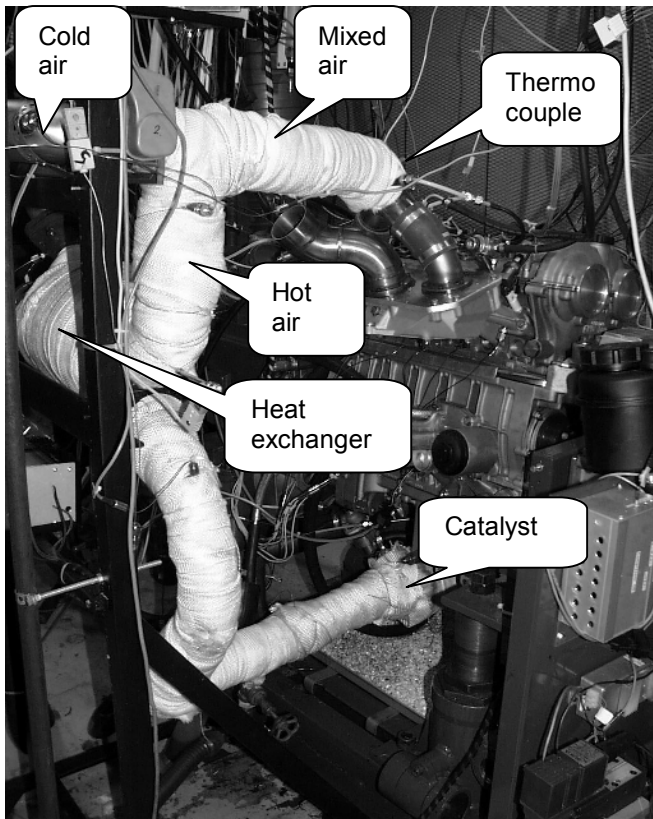

Figure 3 SVC engine with heat recovery system.

The engine speed is controlled by the dynamometer, which has its own speed control. In previous speed transients [16], the set point for engine speed was manually controlled through a potentiometer. For the present tests the speed ramps are controlled from the combustion-control PC, which sets a set point to the dynamometer controller. This results in repeatable speed ramps as fast as the dynamometer controller allows.

CONTROL SYSTEM

SOFTWARE

The control program is originally written by Olsson et al. [11] in Borland Delphi, but modified and developed further for this engine and used in previous papers [14,15,16]. The main differences are crank angle based measurement of inlet temperature, inlet pressure and CR. Olsson et al. controlled combustion phasing using the ratio of two fuels with different octane numbers. We use CR and inlet air temperature instead to control the compression temperature and hence CA50. Figure 4 shows a schematic of the control and measurement system. It is possible to shift between CLCC using variable compression ratio and CLCC using FTM in the Graphical User Interface (GUI). The CLCC using variable CR was shown in a previous paper [16] together with the presently used cylinder balancing strategy with variable lambda.

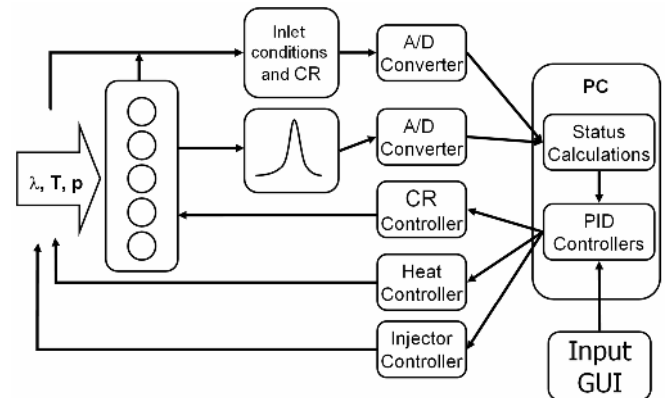

Figure 4 Schematic of control and measurement system.

LOAD CONTROL

When combustion efficiency, as well as the thermodynamic efficiency changes due to advanced or retarded CA50 the load changes in spite of constant injected fuel amount. Load control is therefore desirable. IMEP is already calculated in the program and it is easier to use than BMEP. It is therefore used for the load control shown in Figure 5. A mean IMEP is calculated from all cylinders. This is compared to the set point and a fuel amount is then set by the PID controller.

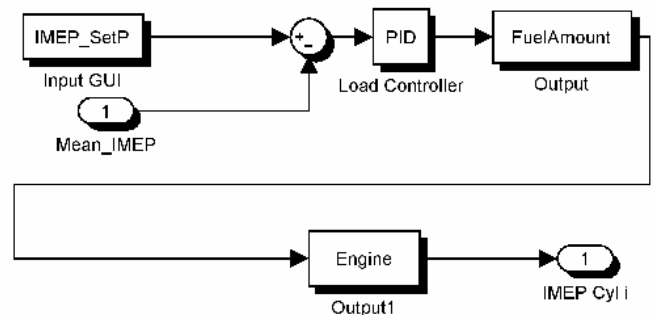

Figure 5 Load control.

The set fuel amount can then be adjusted cylinder-individually if cylinder balancing is enabled and hence results in deviation in cylinder-individual IMEP, while mean IMEP is kept constant.

FAST THERMAL MANAGEMENT

The CLCC using FTM shown in Figure 6 is designed to keep a desired CA50 at all times. It uses a mean CA50 for all cylinders and compares that to the set point for the cylinder in question. The result is sent to the PID controller where a duty cycle for a PWM signal is calculated. The hot air throttle receives the PWM with the calculated duty cycle, while the cold air throttle works with an inverse duty cycle i.e. if the hot throttle is wide open the cold one is shut.

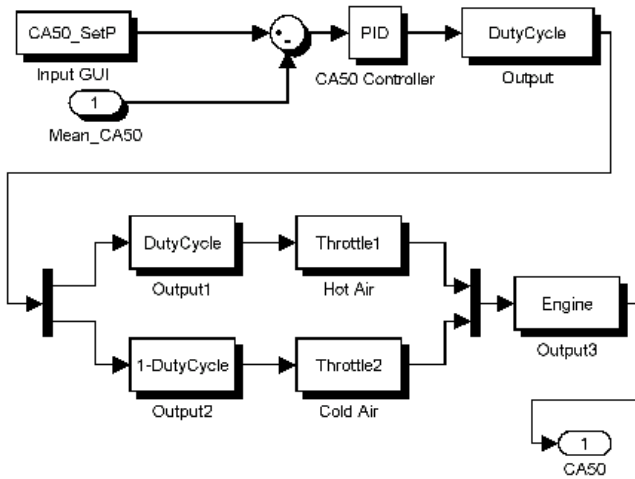

Figure 6 Closed-Loop Combustion Control using Fast Thermal Management.

The FTM is an engine-global control parameter but it is still possible to set cylinder-individual CA50 with the cylinder balancing controller [16]. When the CLCC using FTM is enabled the CLCC using VCR is disabled. It is however possible to set CR manually from the GUI.

RESULTS

CLOSED-LOOP COMBUSTION CONTROL USING FTM

Response to step change in CA50

Performance of the CLCC using FTM is tested by doing step changes in CA50 between 1 and 9 CAD ATDC at 2000 rpm and 2 bar BMEP, shown in Figure 7. The upper plot in Figure 7 shows the throttle set point, the second plot shows the resulting inlet air temperature, which controls CA50 in the third plot. The thin line shows the CA50 set point and the thick line represents measured CA50. In the last plot mean IMEP net for the five cylinders is plotted. The CR is at its maximum of 21 not to saturate the FTM controller. For the advanced combustion phasing case a temperature of almost 190°C is needed and when CA50 is retarded the temperature is down to 136°C. COV IMEP is 2.2% for the entire 300 engine cycles, where an engine cycle is defined as two revolutions of the engine consisting of five combustion events.

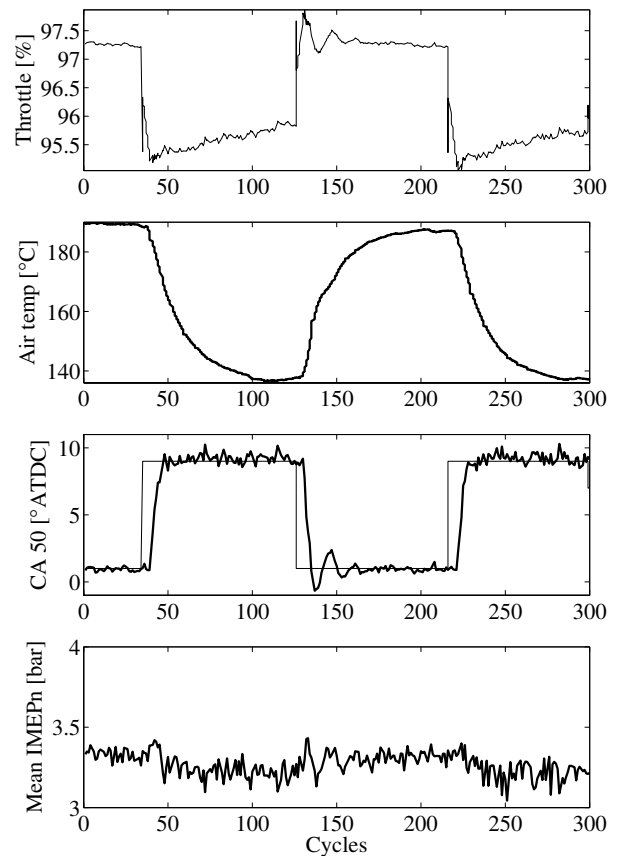

Figure 7 Step change in CA50 at 2 bar BMEP and 2000 rpm.

A delay of almost 4 engine cycles before anything happens is a result of an excessively long distance between the throttle and the inlet valves. This phenomenon is shown in Figure 8, which is a close up of the first positive step in Figure 7. The inlet air temperature measurement is too slow and does not reflect how fast the inlet temperature changes. Since nothing else is changed during the transient, the inlet air temperature should be almost an exact inverse of CA50. This is not the case and calculation from the step response gives a time constant of 1.2s or 21 engine cycles at 2000 rpm for the thermocouple. This is by far too slow to resolve the actual inlet air temperature and for that reason the inlet air temperature is not shown in subsequent plots.

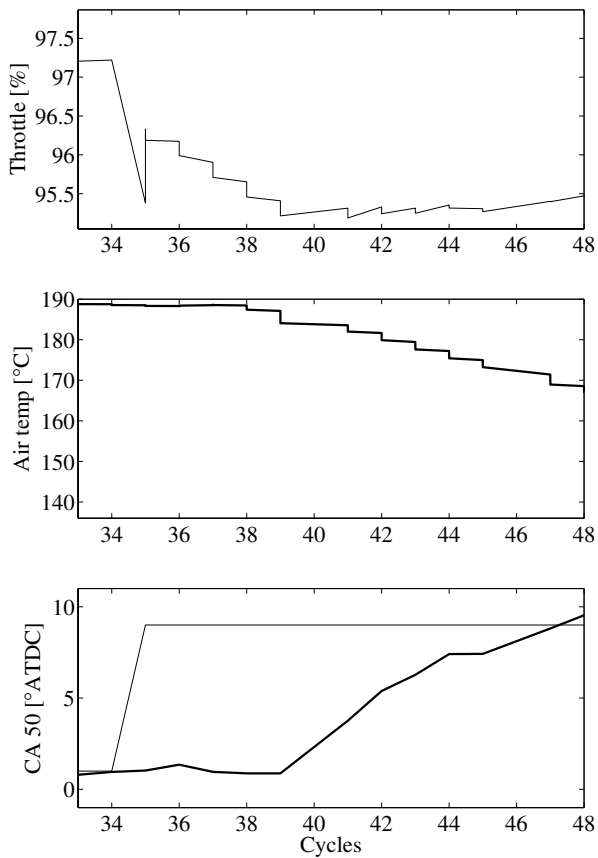

Figure 8 Close up of positive step in CA50.

The throttle set point in the upper plot in Figure 8 changes instantly between cycles 34 and 35. While the thermocouple for air temperature needs three engine cycles to react it is seen in the lower plot that CA50 is unaffected until cycle 40. A fairly rough estimate of the volume between the throttle for cold air and the inlet valves gives 5.5L. With a displaced volume of 1.6L this gives 3.4 engine cycles which explains the response time. The time constant for this step is 8 engine cycles which is equivalent to 0.48s at 2000 rpm to be compared with 14 engine cycles for the cascade coupled CLCC using VCR shown earlier [16]. Note that the PID parameters for this test case are rather fast and will result in unsteady behavior at higher engine speeds. With gain scheduling with respect to engine speed this can be avoided, but has not been implemented here. For the CLCC using VCR more moderate PID parameters were chosen to handle the speed ramps since no gain scheduling had been planned. It is however possible to implement gain scheduling on that controller as well.

Response to step change in CR

A possible control strategy for this engine could include CLCC using both FTM and VCR simultaneously. It is therefore of greatest interest how the CLCC using FTM responds to a step change in CR, which is shown in Figure 9. In the upper plot CR, thick line, and CR set point, thin line, are plotted. The CR controller has typically a time constant of 3 engine cycles [16], and the CLCC using FTM sets a new throttle set point instantly in response to the CR change. CA50 then deviates from the set value of 7 CAD ATDC enough for total misfire on some cylinders. The step from 20 to 19 in CR requires a temperature change of 26°C up to almost 186°C, which is very near the highest reachable temperature at this load and speed. This is probably one reason why the CLCC using FTM does not manage to keep CA50 constant. Another reason is the delay of 3 engine cycles from the hot air throttle and the inlet. These 3 engine cycles is exactly the time between CR is actually changed to 19 at engine cycle 15 and the maximum deviation in CA50 at engine cycle 18. It then takes an additional 5 engine cycles for the CLCC using FTM to minimize the deviation in CA50.

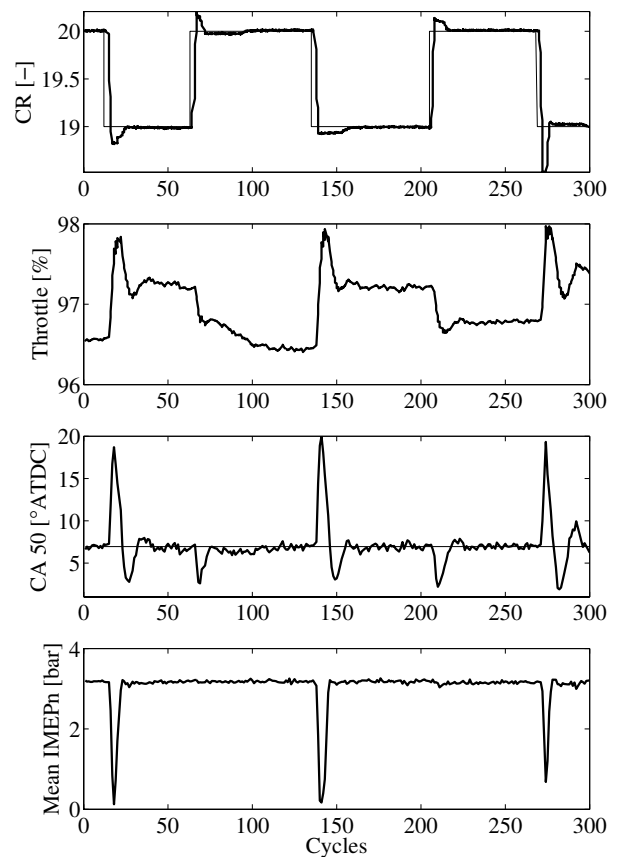

Figure 9 Response to a step change in CR between 19 and 20 at 2 bar BMEP and 2000 rpm.

Controlling CA50 during increasing CR is not at all as demanding and only small deviations in CA50 occur, which do not influence the load at all. This is not the case with the negative step, where misfires result in very large drops in load. This can be avoided by changing CR smoother and/or fitting the throttle closer to the inlet valves and hence minimize the time delay between throttle position and inlet air temperature to the in-cylinder charge.

Response to step change in load

The FTM's ability to handle step changes in load is shown in Figure 10, where FuelMEP [21] is changed to values that correspond to 1.5 bar and 2.5 bar BMEP.

$$FuelMEP = \frac{m_f \cdot Q_{LHV}}{V_d}$$

Where m_f is supplied fuel per cycle, Q_{LHV} is the lower heating value for the fuel and V_d is the displacement volume of the engine.

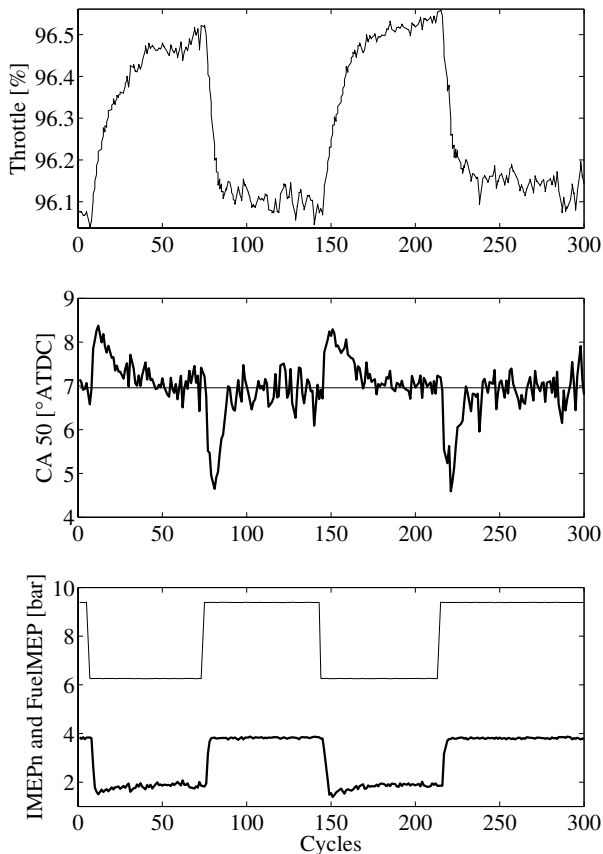

Figure 10 Step change in FuelMEP between 2.5 bar and 1.5 bar BMEP at 2000 rpm.

When FuelMEP is decreased CA50 is retarded 1.4 CAD due to leaner air fuel mixture. The CLCC then increases the hot throttle opening which results in increasing inlet air temperature and a decreased deviation of CA50 from the CA50 set point. When FuelMEP is increased by the load controller, CA50 is instead advanced by 2.3 CAD due to richer mixture, which is comparable to the 2.5 CAD for the CLCC using VCR [16].

Response to ramp change in engine speed

Previous tests have shown difficulties to control CA50 during speed transients [16]. It is found to be very dependent on the fuel used and this is discussed more extensively at the speed ramp limitations section later in this paper. Response to ramp changes in speed is shown in Figure 11. The typical mean speed rate changes, dN/dt , are 13 and -9.7 rev/s^2 for the positive and negative speed ramps respectively. The difference in rate change between the positive and negative ramp is most likely due to engine load. In this test less aggressive PID parameters are used to ensure stable control during the complete speed ramp. This results in slower control performance at lower engine speeds.

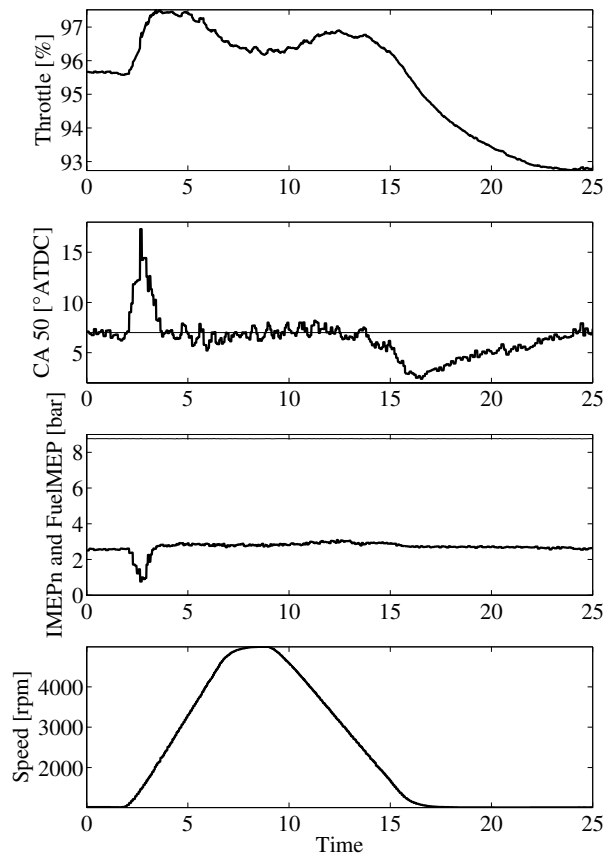

Figure 11 Speed ramp from 1000 to 5000 rpm and back at CR 20 and 2 bar BMEP.

FuelMEP, thin line in the third plot, is kept constant during the entire speed ramp corresponding to 2 bar BMEP at 2000 rpm. During the positive step total misfire occurs from 2.6s for one or two of the cylinders during 1s until the CLCC has increased the inlet temperature enough to keep the CA50 set point. This is not acceptable and some possible improvements are discussed in the next section and more extensively under the speed ramp limitations section.

IMPROVED CLOSED-LOOP COMBUSTION CONTROL USING FTM AND LOAD CONTROL

Response to step change in load

Performance of the load controller is tested by doing repeated step changes in the IMEP set point between 4.3 and 2.3 bar IMEP shown in Figure 12. These loads correspond 3 and 1 bar BMEP respectively. The last plot shows IMEP set point, thin line, mean IMEP, thick line and FuelMEP, thick line.

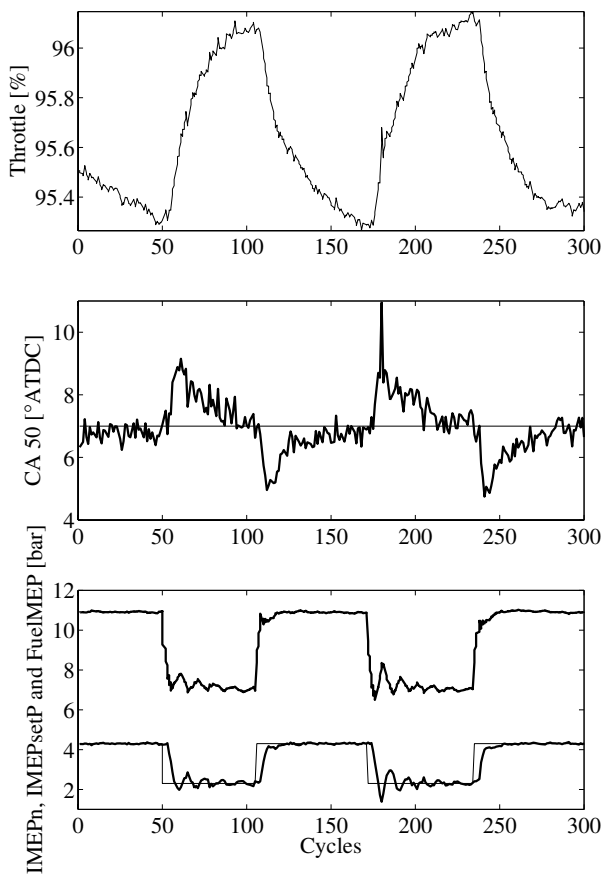

Figure 12 Step response of load step between 3 and 1 bar BMEP.

The load is decreased at engine cycle 50 and at engine cycle 56 it is down to 63% of the set value i.e. a time constant of 6 engine cycles or 0.36s at 2000 rpm. When

the load is increased it makes a much smoother and more controlled adjustment, and with a slightly shorter time constant of 5 engine cycles or 0.30s.

Response to ramp change in engine speed using load control

By conducting a ramp in engine speed the load controller performance is tested together with the CLCC using FTM. The load controller should ideally be able to keep the set value during the entire speed ramp. The disturbance to the load controller in Figure 13 is the change in load when CA50 is retarded and close to misfire due to an excessively fast speed ramp for the CLCC. IMEP, thick line, and the IMEP set point, thin line is shown in the lower part of plot three in Figure 13, while FuelMEP, thick line is in the upper part of plot three. There is a little ripple on the IMEP line around the set point of 3 bar at the same time as CA50 is retarded. IMEP drops below the set point for 0.4s and is down to 2.3 bar at its minimum, but when CA50 deviates the most the load controller has already minimized the deviation in load. It however overshoots up to 3.7 bar due to the increased FuelMEP, since load is automatically increased when CA50 advances.

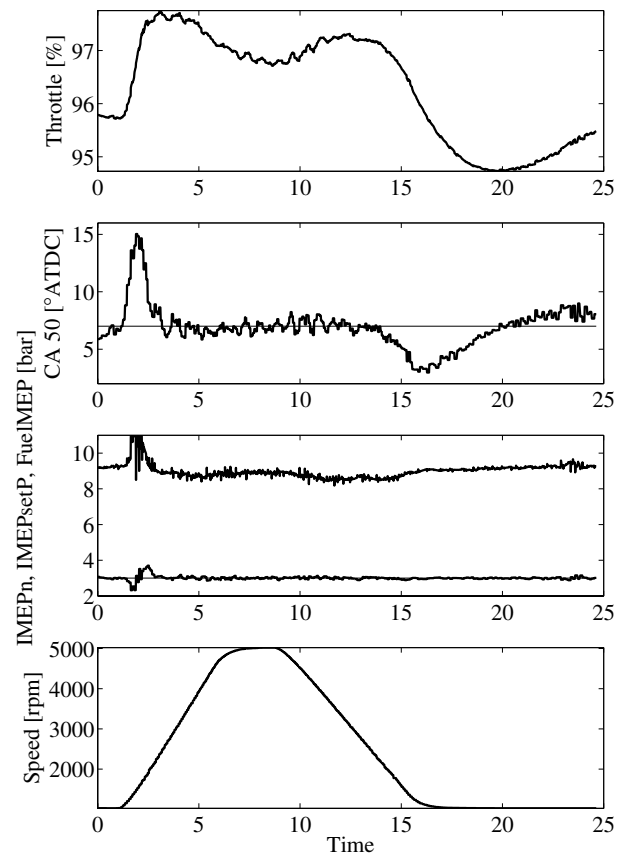

Figure 13 Speed ramp from 1000 to 5000 rpm and back at CR 19 and 3 bar IMEP using load control.

The CA50 advance is a function of both the FTM and the load controller. FuelIMEP is then decreased and the controller keeps IMEP within ± 0.1 bar for the rest of the speed ramp. The load is never below 2.3 bar IMEP, while for the case with no load control in Figure 11 the load is down to 0.8 bar IMEP, hence combined load control and CLCC using FTM improves handling of the speed ramp.

SPEED RAMP LIMITATIONS

As shown in the speed ramps in Figure 11 and Figure 13 it is very difficult to control CA50 during the beginning of the speed ramp. Tests with speed ramps are done from 1200 to 5000 rpm with much better result than from 1000 to 5000 rpm.

The very large increase in CR/inlet air temperature required for a modest increase in speed from 1000 to 1200 rpm lead to an investigation of different fuels. To be able to control CA50 during the speed ramps further understanding of the mechanisms are necessary and an additional test is conducted to find an explanation for the current behavior. Four test cases are chosen, shown in Table 2. The intention is to find why a dramatic increase in inlet air temperature is required for a very modest increase of 200 rpm from 1000 rpm. For this steady state test CA50 is set to 7 CAD ATDC and the CLCC using FTM is enabled.

Table 2 Steady state test cases

Fuel	Lambda	CR
PRF 100 (pure Isooctane)	2.4	21
PRF 60 (blend of isooctane and n-heptane)	2.5	14.5
RON 92 / MON 82	2.4	21
RON 92 / MON 82	3.1	21

RON 92 is the fuel used for all the transients in this paper and PRF 60 is a mixture of 60% isooctane and 40 % n-heptane used in an earlier paper [10]. The PRF 100 fuel consists of pure isooctane.

Temperature range

The steady state operating points are shown in Figure 14, where each marker is a mean value of all five cylinders and 300 engine cycles. The plot indicates that the largest increase in inlet air temperature is needed for PRF 60, while all fuels level out after 2000 rpm. The

PRF 60 could not be tested at higher speed than 2000 rpm due to saturated inlet air temperature. It would have been possible to increase CR, but that would result in a need to cool the inlet air for the low engine speed. The PRF 100 upper speed is limited by maximum rate of pressure rise. This is also the case for the fuel rich RON 92 tests, while the lean RON 92 is tested over the entire speed range. The large increase in inlet air temperature is the explanation for difficulties with combustion control between 1000 and 1200 rpm. The temperature rise is steeper for a more fuel rich mixture and PRF 60 requires a much larger temperature increase than RON 92, while isooctane is more linear.

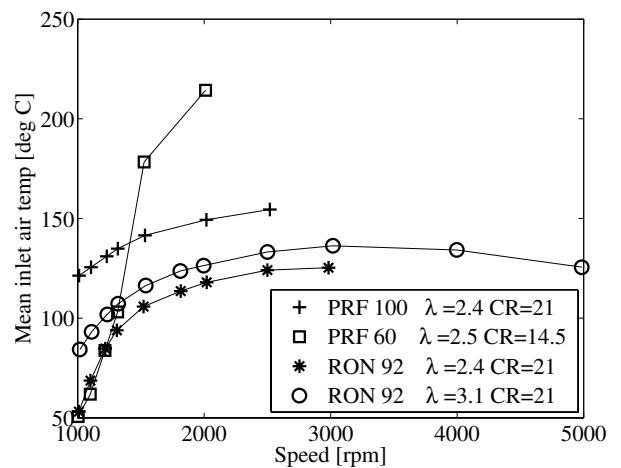

Figure 14 Mean inlet air temperature for 300 engine cycles for steady state measuring points of speed for the four test cases.

Kelly-Zion and Dec [22] made a computational study addressing the influence of speed and fuel and explains this behavior to derive from two-stage ignition of the fuel where the first stage of ignition is deemed Low Temperature Reactions (LTR). They performed simulations with pure isooctane and pure n-heptane.

Low Temperature Reaction influence

No LTR are apparent for the PRF 100 case and the RON 92 with lambda 3.1. However for the PRF 60 and the RON 92 with lambda 2.4 there are LTR present. Since the LTR behavior is more pronounced for the PRF 60 test case this is shown here in Figure 15, where the most prominent LTR are present for the lowest engine speed. Increasing the engine speed results in a need to increase inlet air temperature, Figure 14, to keep CA50. This result in less LTR and finally at 1500-2000 rpm the LTR disappear. This is consistent with Aroonsrisopon et al. [23,24], who ran an engine with various fuels and speeds with constant inlet air temperature and hence no CA50 control. In our case the LTR appear earlier in CAD as engine speed increase since inlet air temperature is increased by the CLCC, but when looking at the time between maximum LTR and maximum rate of heat

release, this time is approximately 3.5ms for all engine speeds.

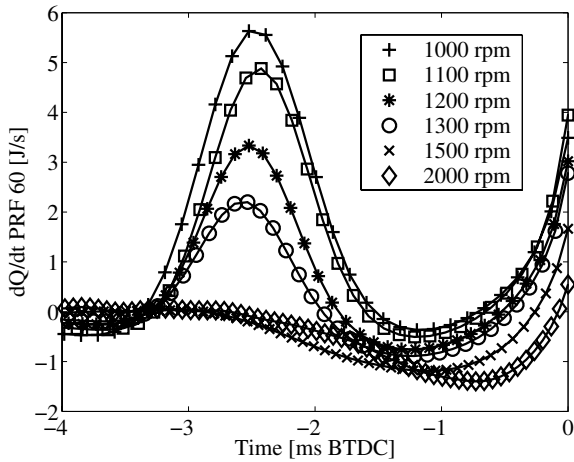

Figure 15 Low Temperature Reactions for five cylinders and 300 engine cycles as a function time for six different speeds for the PRF 60 test case.

The cylinder pressure at start of LTR decreases and the temperature increases for increasing engine speeds, seen in Table 3. Here also the CAD for start of LTR and the time available from Inlet Valve Closure (IVC) to TDC is given.

Table 3 Low Temperature Reaction properties for the PRF 60 test case.

Engine Speed [rpm]	1000	1100	1200	1300	1500	2000
LTR	Yes	Yes	Yes	Yes	No	No
Inlet Valve Closure [ms BTDC]	22.4	20.5	18.4	17	14.6	10.8
Start of LTR [CAD BTDC]	18.4	19.2	21.6	23.2	NA	NA
Temp at start of LTR [K]	702	721	741	760	NA	NA
Pressure at start of LTR [bar]	19.8	19.2	17.2	16.0	NA	NA

For the case of RON 92 and lambda 2.4 the LTR are not so large, but they are however quite noticeable when running the engine at the two points where they are present. This is seen in Figure 14, where significantly lower inlet air temperature is needed for the first two points, with LTR, than for the lambda 3.2 case with same fuel and no LTR. Fieweger et al. [26] show LTR for various isoctane and n-heptane mixtures at approximately the same temperatures given in Table 3 with experiments using a rapid compression machine. The LTR delay time for their experiments range from 0.3ms at the highest temperature to 2ms at the lowest temperature for PRF 60, with a stoichiometric mixture and a pressure of 40 bar. Pressure and lambda however does not have as large influence on delay time as temperature and n-heptane contents [26]. The engine needs lower inlet air temperature when LTR are apparent, but when the LTR disappear, as engine speed increases, a very much higher inlet air temperature is required.

SOLUTIONS TO SPEED RAMP LIMITATIONS

Fuel choice

The obvious solution to this problem is to use a fuel with no cool flame behavior like Isooctane as suggested by Kelly-Zion and Dec [21]. This however would lead to problems with this particular engine, which suffers from large heat losses and hence needs very high CR and/or inlet air temperature to run fuels like Isooctane. With high CR and/or inlet air temperature the cylinder to cylinder variations increase dramatically, due to variations in cylinder head casting and a large temperature difference between inlet air and surrounding materials. Another disadvantage is the thermal throttling associated with high inlet air temperatures which limits the maximum load severely [10,14,15]. If instead a fuel with LTR over a wide range of pressures and temperatures were used it would be possible to run the engine at lower inlet air temperatures and/or CR. Investigating the LTR behavior gives a duration for the LTR of 2ms and a minimum time between inlet valve closure and succeeding start of LTR of 14ms. For longer times i.e. lower engine speeds the LTR are larger.

Avoid Low Temperature Reactions region for given fuel

Another solution is to avoid the LTR region. The LTR region can be mapped as a function of auto ignition temperature and pressure [25]. This can then be used in a more advanced control algorithm. No identification of the LTR region is done here, but the speed ramp in Figure 11 is run both with a CR of 21 and 20 without load control. For the CR=21 test the handling of the ramp is not acceptable, it is however considerably improved when CR is decreased. This can be explained by the LTR region, which most likely is more or less avoided when CR is decreased and inlet air temperature is increased. Fieweger et al. [26] show no LTR above 825K for PRF 60 or 880K for PRF 100. This implies that decreasing CR and increasing inlet air temperature

rendering an auto ignition temperature above 825K for PRF 60 would result in a more linear increase in inlet air temperature during the speed transient and improved handling by the CLCC using FTM.

Instead of decreasing CR it is possible to advance CA50, which with the CLCC using FTM leads to an increased inlet air temperature. Manual change of set point from the GUI is tested, Figure 16. The CA50 set point is set to 3 CAD ATDC at low engine speed. When speed is increased CA50 set point is retarded to 7 CAD ATDC and then back again as speed is decreased. This resulted in a maximum deviation of 6 CAD from the CA50 set point of 3 CAD ATDC, hence no misfire. The advanced combustion phasing is also favorable for the combustion efficiency at low loads [15].

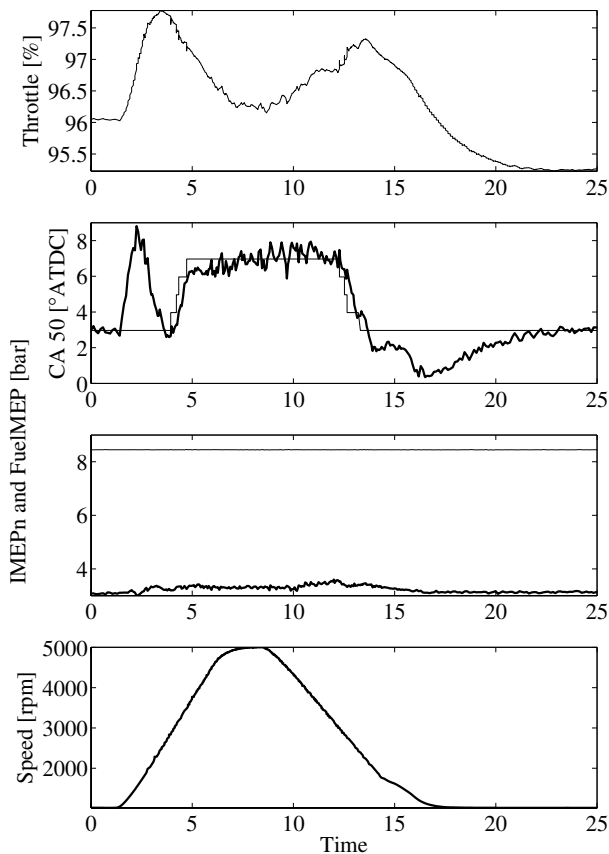

Figure 16 Speed ramp from 1000 to 5000 rpm and back at CR 20 and 2 bar BMEP while changing CA50 set point.

Improve the CLCC

Gain scheduling of the PID parameters as a function of engine speed would be another solution to improve the CLCCs handling of speed ramps, since all control is crank angle based, the control loops run slower at low engine speeds. This type of gain scheduling is not

implemented in the control program, but it is used manually by setting different control parameters for the tests at 2000 rpm and for the transients.

Faster response time for the CLCC is another improvement which would reduce the time lag (currently four engine cycles). The solution is to fit the throttles as close to the inlet as possible with a possible drawback of inhomogeneous air temperature to the inlet which can result in larger cylinder to cylinder variations.

CONCLUSIONS

- The Closed-loop combustion control using fast thermal management is shown to handle transients in a similar or even better manner than the closed-loop combustion control using variable compression ratio shown earlier.
- The closed-loop combustion control using fast thermal management is an alternative combustion phasing device to variable compression ratio and variable valve timing systems.
- A step change in CA50 has a time constant of 8 engine cycles even though the system has a time lag of 3 engine cycles due to large volume between mixing and inlet. The time constant improvement is 57% compared to earlier variable compression ratio system.
- The load controller handle load steps and speed ramps satisfactorily and has a time constant of 5 to 6 engine cycles or 0.30 to 0.36s at 2000 rpm.
- The speed ramps are severely influenced by low temperature reactions between 1000 and 1200 rpm, due to the speed and temperature dependent nature of low temperature reactions. Speed ramps are however handled satisfactorily when using a speed dependent combustion phasing and/or decreasing compression ratio thus increasing inlet air temperature to avoid low temperature reactions to interfere.

REFERENCES

1. S. Onishi, S. Hong Jo, K. Shoda, P. Do Jo, S. Kato, "Active Thermo-Atmosphere Combustion (ATAC) – A New Combustion Process for Internal Combustion Engines", SAE790501
2. Y. Ishibashi, M. Asai, "Improving the Exhaust Emissions of Two-Stroke Engines by Applying the Activated Radical Combustion", SAE960742
3. P. Najt, D. E. Foster, "Compression-Ignited Homogeneous Charge Combustion", SAE830264
4. R. H. Thring, "Homogeneous-Charge Compression-Ignition (HCCI) Engines", SAE892068
5. M. Stockinger, H. Schäpertöns, P. Kuhlmann, "Versuche an einem gemischansaugenden mit Selbstzündung", MTZ 53 (1992).
6. M. Christensen, P. Einewall, B. Johansson, "Homogeneous Charge Compression Ignition (HCCI) Using Isooctane, Ethanol and Natural Gas – A Comparison to Spark Ignition Operation", SAE972874
7. M. Christensen, B. Johansson, P. Amnéus, F. Mauss, "Supercharged Homogeneous Charge Compression Ignition", SAE 980787
8. M. Christensen, B. Johansson: "Influence of Mixture Quality on Homogeneous Charge Compression Ignition", SAE982454
9. M. Christensen, B. Johansson, "Homogeneous Charge Compression Ignition with Water Injection", SAE1999-01-0182
10. G. Haraldsson, J. Hyvönen, P. Tunestål, B. Johansson, "HCCI Combustion Phasing in a Multi Cylinder Engine Using Variable Compression Ratio", SAE 2002-01-2858.
11. J-O. Olsson, P. Tunestål, B. Johansson, "Closed-Loop Control of an HCCI Engine", SAE 2001-01-1031
12. M. Christensen, A. Hultqvist, B. Johansson, "Demonstrating the Multi Fuel Capability for a Homogeneous Charge Compression ignition Engine with Variable Compression Ratio", SAE 1999-01-3679
13. J-O. Olsson, P. Tunestål, B. Johansson, S. Fiveland, R. Agama, M. Willi, D. Assanis, "Compression Ratio Influence on Maximum Load of a Natural Gas Fueled HCCI Engine" SAE 2002-01-0111
14. J. Hyvönen, G. Haraldsson, B. Johansson, "Operating range in a Multi Cylinder engine using Variable Compression Ratio" JSAE 20030178/ SAE 2003-01-182
15. J. Hyvönen, G. Haraldsson, B. Johansson, "Supercharging HCCI to extend the operating range in a Multi-Cylinder VCR-HCCI engine" SAE 2003-01-3214
16. G. Haraldsson, J. Hyvönen, P. Tunestål, B. Johansson, "HCCI Combustion Phasing with Closed-Loop Combustion Control Using Variable Compression Ratio in a Multi Cylinder Engine", JSAE 200301126/SAE 2003-01-1830
17. F. Agrell, H-E. Ångström, B. Eriksson, J. Wikander, J. Linderyd, "Integrated Simulation and Engine Test of Closed Loop HCCI Control by Aid of Variable Valve Timings", SAE 2003-01-0748
18. J. Yang, T. Culp, T. Kenney, "Development of a Gasoline Engine System Using HCCI Technology – The Concept and the Test Results" SAE 2002-01-2832
19. J-O. Olsson, P. Tunestål, G. Haraldsson, B. Johansson, "A Turbo Charged Dual Fuel HCCI Engine", SAE 2001-01-1896
20. H. Drangel, L. Bergsten, "The new Saab SVC Engine - An Interaction of Variable Compression Ratio, High Pressure Supercharging and Downsizing for Considerably Reduced Fuel Consumption", 9. Aachener Kolloquium Fahrzeug- und Motorentechnik 2000
21. O. Erlandsson, "Thermodynamic Simulation of HCCI Engine Systems", Doctoral Thesis, Lund 2002
22. P. L. Kelly-Zion, J. E. Dec, "A Computational Study of the Effect of Fuel-Type on Ignition Time in HCCI Engines", Proceedings of the Combustion Institute, Vol 28, Part 1, pp. 1187-1194, 2000
23. T. Aroonsrisopon, D. Foster, T. Morikawa, M. Lida, "Comparison of HCCI Operating Ranges for Combinations of Intake Temperature, Engine Speed and Fuel Composition", SAE 2002-01-1924
24. T. Aroonsrisopon, V. Sohm, P. Werner, D. E. Foster, T. Morikawa, M. Lida, "An Investigation Into the Effect of Fuel Composition on HCCI Combustion Characteristics", SAE 2002-01-2830
25. J. B. Heywood, "Internal Combustion Engine Fundamentals", McGraw-Hill, page 465, 1988
26. K. Fieweger, R. Blumenthal, G. Adomeit, "Self-Ignition of S.I. Engine Models Fuels: A Shock Tube Investigation at High Pressure", Combustion and Flame 109, pp 599-619, 1997

CONTACT

Göran Haraldsson, MSc M. E.
E-mail: goran.haraldsson@vok.lth.se

Jari Hyvönen, MSc M. E.
E-mail: jari.hyvonen@vok.lth.se

Per Tunestål, Assistant Professor
E-mail: per.tunestal@vok.lth.se

Bengt Johansson, Professor.
E-mail: bengt.johansson@vok.lth.se

Department of Heat and Power Engineering, Division of
Combustion Engines, Lund Institute of Technology, P.O.
Box 118, SE-221 00 Lund, Sweden.

DEFINITIONS, ACRONYMS, ABBREVIATIONS

ATDC: After Top Dead Centre

BMEP: Brake Mean Effective Pressure

BTDC: Before Top Dead Centre

CAD: Crank Angle Degree

CA50: Crank Angle for 50% burned

CI: Compression Ignition

CLCC: Closed-Loop Combustion Control

COV: Coefficient Of Variation

CR: Compression Ratio

dN/dt: Rate of Speed increase

EGR: Exhaust Gas Recirculation

FTM: Fast Thermal Management

GUI: Graphical User Interface

HCCI: Homogeneous Charge Compression Ignition

IMEP: Indicated Mean Effective Pressure

IVC: Inlet Valve Closure

LTR: Low Temperature Reactions

PID: Proportional Integral Derivative

PRF: Primary Reference Fuel

PWM: Pulse Width Modulation

RON: Research Octane Number

SI: Spark Ignition

SVC: Saab Variable Compression

TDC: Top Dead Center

VCR: Variable Compression Ratio