

High bit rate optical transmission using midspan spectral inversion

Atef Benhaoues, Hichem Mayache et Salah Toumi

Laboratoire d'Etude et de Recherche en Instrumentation et en Communication d'Annaba
(LERICA), Département d'Electronique,
Université Badji Mokhtar, BP 12, Annaba 23000, Algerie.

Accepté le 28/02/2010

ملخص

يمكن لمشكلة الضوضاء الناتجة عن آثار المرحلة الغير خطية والتشتت اللوني الحد من مسافة البث، ومعدل الثنائي (bit) لمرحلة-التحول-القفل حالات التعديل. في هذا المقال، درسنا تعويضات الآثار الغير الخطية والخطية عن طريق منتصف امتداد المرحلة البصرية المرفقة (OPC). أولاً، نظهر آثار التشتت اللوني في نظام OD8PSK (تفاضلية ضوئية المستوى-8 مرحلة-التحول-القفل)، ثم دراسة محاكاة بث المسافات الطويلة لتفاضلية ضوئية المستوى-8 مرحلة-التحول-القفل (OD8PSK) من أجل مقارنة أداء كل من تعويضات تشتت الألياف (DCF) و منتصف امتداد المرحلة البصرية المرفقة. ال OPC تسمح بالحصول على أفضل تغطية للمعلومات المرسله وخصوصا عند المقارنة بنظام البث «التقليدي»، هذا الأخير يستخدم ألياف تعويضات التشتت (DCF). OPC لها أداء أفضل حتى إذا زدنا معدل الثنائي والمسافة.

الكلمات المفتاحية: الأشكال المتناوبة للتعديلات؛ تفاضلية ضوئية المستوى-8 مرحلة-التحول-القفل (OD8PSK)؛ تعويضات التشتت؛ الألياف البصرية للاتصالات؛ ضوضاء المرحلة الغير خطية؛ ترافق المرحلة البصرية؛ قلب الطيفية.

Résumé

Le problème du bruit de phase générée par les effets non linéaires et la dispersion chromatique peut limiter la transmission à distance et le débit binaire pour les formats de modulation de phase-shift-keying. Dans cet article, la compensation des effets non linéaires et linéaires par un mi-portée conjugaison de phase optique (OPC) est étudiée. Tout d'abord, nous montrons les effets de la dispersion chromatique dans un système OD8PSK (Optique Différentielle 8-Niveau Phase-Shift Keying), puis un différentiel de long-courriers 8-niveau de la phase-Shift Keying (OD8PSK) de simulation de transmission est étudiée afin de comparer les performances de la compensation de dispersion de fibres (DCF) et la mi-portée conjugaison de phase optique. OPC permettent d'obtenir une meilleure récupération de l'information transmise surtout par rapport à un système de «conventionnel» de transmission ; celui-ci utilise la fibre de compensation de dispersion (DCF). OPC donne de meilleurs résultats, même si l'on augmente le débit et la distance.

Mots clés : formats alternatives de modulation; Optique différentielle 8-Niveau Phase-Shift Keying (OD8PSK); compensation de dispersion; fibres optiques de communication; bruit de phase non linéaire; conjugaison de phase optique; inversion spectrale.

Abstract

The problem of the phase noise generated by nonlinear effects and chromatic dispersion can limit the transmission distance and the bit rate for phase-shift-keying modulation formats. In this paper, the compensation of the nonlinear and linear effects by a midspan optical phase conjugation (OPC) is studied. First, we show the impacts of chromatic dispersion in an OD8PSK systems (Optical Differential 8-Level Phase-Shift Keying), then a long-haul differential 8-Level Phase-Shift Keying (OD8PSK) transmission simulation is studied in order to compare both the performance of the dispersion compensating fiber (DCF) and the midspan optical phase conjugation. OPC allow to obtain a best recovered of transmitted information especially when compared to a «conventional» transmission system; the latter uses dispersion compensating fiber (DCF). OPC performs better even if we increase the bit rate and the distance.

Key words: alternative modulation formats; Optical Differential 8-Level Phase-Shift Keying (OD8PSK); dispersion compensation; fiber optics communications; nonlinear phase noise; optical phase conjugation; spectral inversion.

Auteur correspondant: sti_atef@hotmail.fr(A. Benhaoues)

1. INTRODUCTION

Nowadays, the requirements to increase capacity and reach and to reduce cost are higher; consequently one solution is to use multilevel modulation formats which have a lot of advantages when compared to competing methods. Since multilevel modulation formats allow higher spectral efficiency [1], the capacity can be increased without expanding the overall bandwidth of the system, allowing the use of existing optical amplifier technology instead of developing new amplifier technology. Optical differential quaternary phase-shift keying (DQPSK), [2] and optical differential eight-level phase-shift keying (OD8PSK) [3-9], were proposed and their performance was checked by digital simulations [5-12]. The constant intensity of the signal in this modulation formats (the intensity is not modulated by the data), offers a better tolerance to nonlinearity XPM (cross phase modulation). In addition, a direct detection makes the reception simpler (without use of local oscillators which are necessary in homodyne detection). However, phase-shift-keyed transmission suffers from problems during the propagation. In fact, chromatic dispersion and nonlinearity (SPM: self-phase modulation) induce a phase shift when added to the phase of the original signal OD8PSK causes an error of the detection during demodulation.

The use of chromatic dispersion compensation fiber (DCF) gives good results (best recovered of transmitted data) if we neglect the effect of self-phase modulation (SPM). Unfortunately, if the distance from transmission is longer, it is then necessary to take into account the effect of the SPM on the phase.

The mid-span spectral inversion (MSSI) is a promising technology to reduce the problem of the phase in the case of DPSK transmission [4-7]. The latter is similar to the OD8PSK modulation; they both use the

phase to transmit information. The MSSI is also known under (*Optical Phase Conjugation "OPC"*) compensates at the same time the chromatic dispersion and the SPM [8-13].

The principle of MSSI is the spectral inversion of the spectrum of optical signal, and it is placed in the middle of the transmission span [7-8]. In the first half of the span, the signal disperses, thus generating distorted impulses where the red components precede the blue ones. This dispersed signal undergoes then a phase conjugation which reverses its optical spectrum in its second half, chromatic dispersion recompresses the impulse. If the dispersion before and after the phase conjugator is the same, then the original impulse will be restored at the end of the span.

OPC technique is able to remove the deformation induced by the SPM, in fact when an OPC is placed in the middle of the fiber, for the first half the phase shift of the SPM is added to the original signal phase and the resulting phase is inverted by the OPC, in second half the phase shift of the SPM is added to the inverted phase of the first half. The key advantages of OPC are that multichannel dispersion compensation is possible and that an OPC is transparent to modulation format and to data rate [10-14].

In this paper, the compensation of the nonlinear and linear effects in an OD8PSK system by a midspan optical phase conjugation (OPC) is discussed. The section 2 and the first part of the section 3 describe the simulation of an optical OD8PSK transmission link system using Matlab Simulink. We have analyzed the impairments of system performance which are due to chromatic dispersion effect.

In the second and third part of the section 3, the performance of OPC to compensation of chromatic dispersion and

nonlinear impairments (in order to access to these effects, we have implemented these real performance degrading effects into the simulations based on theoretical knowledge) is compared to conventional dispersion compensating fiber (DCF)-aided transmission. We show that the performance of the DCF-based scheme is severely impaired by SPM-induced impairments, whereas the performance of the OPC is virtually unaffected.

2. SMF FIBER MODELING

A real simulation of an optical communication chain requires the modeling of some types of practical fibers. These fibers are either standard fiber (SMF), or the ones used for the compensation (DCF, DSF...). To model the SMF fibers, we use a transfer function method [6]. This method supposes that SMF fiber has its own transfer function $H(f)$. So to accurately represent fiber propagation [6], we take first the FFT of the input modulated signal, then we multiply the result by $H(f)$ and we finally take the IFFT (inverse FFT).

$$\hat{X}_{out}(f)=H(f).\hat{X}_{in}(f). \quad (1)$$

In this modeling, we take the value of the dispersion (given by ITU); $D_{SMF}=+17ps/nm.km$ at 1550nm, and an attenuation α of 0.2dB/km, this implies a total of optical power attenuation of 16dB after 80km. For our simulation, we take fiber lengths of 80 km and 160km. For a DCF fiber (Dispersion Compensating Fiber), we take $D_{DCF} = -85ps/nm.km$ (negative dispersion to compensate the positive dispersion of SMF fiber) and a fiber of smaller length ($L = 16$ km) having a loss of 0.5dB/km. For the nonlinear effect (SPM), we have a fiber spot size $r_0=4.1*10^{-6}$ in m^2 , non-linear index coefficient $n_2=2.10^{-20}$ in m^2/W , and fiber effective area $A_{eff}=\pi*(r_0)^2$.

The final simulation of an optical fiber with its linear and nonlinear effects is represented by the figure 1 [6].

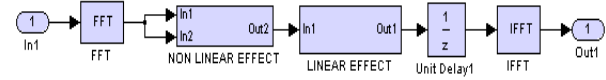

Figure 1. Transfer function based SSMF Simulink model.

In this simulation, it is supposed that the other nonlinear effects (FWM, Raman and Brillouin) and the polarization mode dispersion (PMD) are neglected.

3. SIMULATION IN SINGLE CANAL CONFIGURATION

A proof-of-principle research is described to show that OPC can effectively compensate for impairments that are due to chromatic dispersion and nonlinear effects (SPM). Initial results of this proof of-principle research are reported in [7].

This proof of-principle research was restricted to single channel in order to assess only SPM-induced nonlinear. In order to estimate at the same time the performance of the OPC and DCF techniques, we take the comparison of the phase difference before and after propagation as criterion.

3.1 Chromatic Dispersion Impairment on OD8PSK Transmission

The model is depicted in figure 2. A return-to-zero (RZ)-OD8PSK signal is generated at 1550 nm by a distributed feedback (DFB) laser and by the cascade of external LiNbO3 MZMs modulator and phase modulator (PMs) (Fig. 3) [6]. The first modulator (Fig. 3) is driven with a clock signal which is chosen according to the selected bit rate (we begin with a 10GHz clock signal), carving a pulse with a 63% duty cycle. Then another modulator MZM

phase shift the optical carrier by the amount 0 or π , the output of this modulator is the input of a third phase modulator (PM) which induce a phase shift to the optical carrier by the amount 0 or $\pi/2$, and finally another phase modulator inducing a 0 or $\pi/4$ phase shift. As shown in Fig 3, the four modulators (the RZ pulse carver MZIM, an MZIM and two PMs) are placed in cascade in order to modulate the optical carrier according to the OD8PSK modulation format.

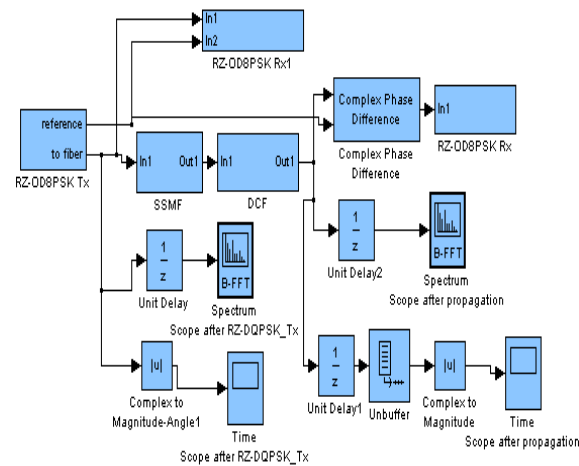

Figure 2. RZ-OD8PSK transmission Simulink optical simulator for single channel transmission with and without DCF.

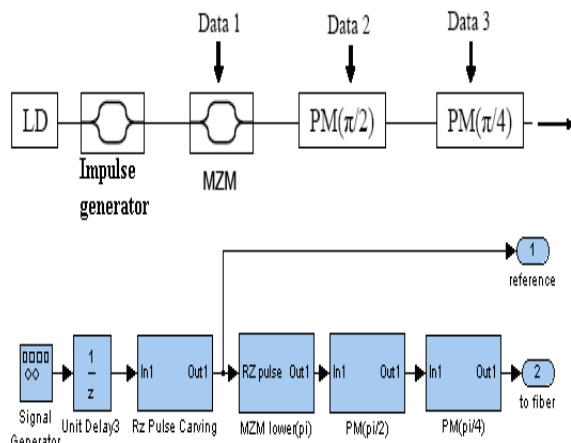

Figure 3. Schematic diagrams of optical encoders for OD8PSK modulation and their Simulink model.

The second MZIM and the phase modulators (PMs) must be driven by random

binary generators of 10 Gb/s or more, according to the selected bit rate.

To simplify some aspects of the transmitter design, we have assumed that there are no chirping effects from the DFB laser, and that the signal generator used to represent the fixed wavelength light waves is ideal. We have also assumed that there are no insertion losses (coupling losses), for the MZIM. The optical intensity characteristic of the MZIM is assumed to be ideal, leading to a large extinction ratio (large dB difference between P_{max} and P_{min}). The minimum output power, P_{min} , of the MZIM is thus modeled mathematically to be zero at the minimum transmission point.

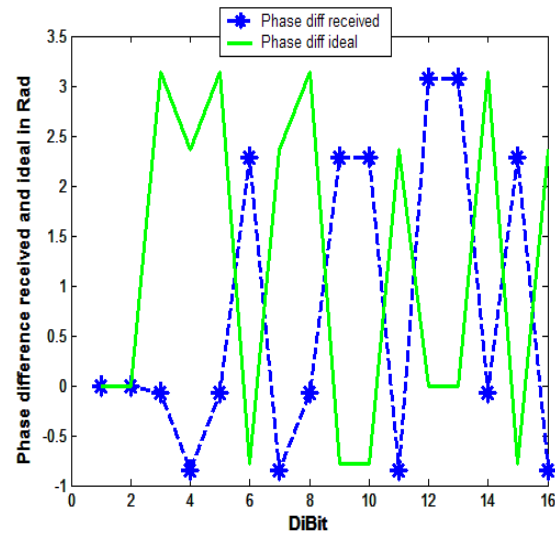

Figure 4. Phase comparison between the expected (transmitted) and received phase differences for 16/256 di-bit transmission over SMF fiber link (No Dispersion Compensation).

The principle operation of the receiver is to convert phase-coded information, such as that generated by the OD8PSK transmitter, into an intensity signal which can be detected by a photodiode circuitry at the output of the delay interferometer (DI) arms. The intensity of the signal at the output of the DI arms is dependant on the phase

difference between adjacent bits of the optical carrier [6].

To illustrate the Impact of the chromatic dispersion, we consider a transmission by SMF fiber of 80 km without any module of compensation (DCF) in place. As can be seen in Fig4, when there is no dispersion compensation management placed in the fiber link, dispersion effects of the fiber corrupt the differential phase of the transmitted symbol. The phase difference (between adjacent symbols) detected by the receiver (Blue plot) is always incorrect. At the receiver, in an MZDI incorrect conversion of phase to intensity, this leads to an incorrect data recovery. It is clear, that the chromatic dispersion of the SMF fiber does not allow using the modulation OD8PSK. In fact, the former generates a phase shift which modifies in a destructive way the phase (of the original signal) that is necessary for demodulation. The high degree of bit recovery error is an indication of the need for dispersion management. The results presented in this section are verified in [6].

3.2 DCF-Aided OD8PSK Transmission

In order to decrease degradations, it is necessary to have a fiber having a chromatic dispersion of opposite sign. Several of these DCF fibers exist with varied enough characteristics. To determine the best optical fiber couple, we must verify two conditions that are:

- i) null cumulated chromatic dispersion.
- ii) cumulated attenuation of the signal equal to 24 dB.

The characteristics selected of the fiber couple are presented by the table 1. The model of the DCF-aided is depicted in Fig.2. We consider a transmission module (by means of SMF fiber of 80 km) and compensation module (by means of DCF fiber of 16 km). Apart from that, the components (transmitter, receiver, etc.) are the same as in the configuration discussed in

the previous section, but we will have to add the SPM (self phase modulation) effect in the SSMF fiber, to illustrate the impact of the former on the transmission.

Table 1. Simulation parameters of fiber couple.

Parameters of fiber	SMF	DCF
Length (km)	80	16
Attenuation (dB/km)	0,2	0,5
Dispersion (ps/nm/km)	17	-85
Kerr Effect	Oui	Oui
Raman Effect	Non	Non
Coefficient of nonlinearity (m ² /W)	2,7.10 ⁻²⁰	7.10 ⁻²⁰
Effective surface of the section (μm ²)	80	30

The SPM by itself is not harmful, due to its small effect, but the erbium doped fiber amplifiers (EDFA) generate amplified spontaneous emission (ASE) noise which causes a change of the optical intensity; this change is converted in phase fluctuations [11] by the nonlinearity of Kerr (SPM). This noise of phase, usually indicated under the name of noise of Gordon Mollenauer, deteriorates the performance of a system of transmission PSK.

Fig.5, illustrates that the chromatic dispersion compensation fiber (DCF) module is not adequate to compensate for all the penalty of the nonlinear effect {the phase difference detected at the receiver is different with that expected}, implying incorrect data retrieval.

Hence, we conjecture that the self phase modulation corrupts the phase which carries information in the case of OD8PSK modulation, and will induce errors of detection on the receiver as previously observed in [7] in the case of DQPSK modulation. In addition, the non linearity of the DCF fiber will increase the phase shift, and given that the effective surface of the

former is very small (tab. 1), the nonlinearity effects will be even bigger.

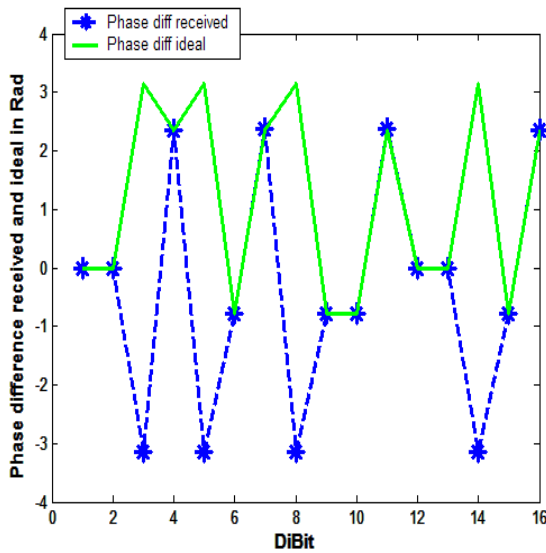

Figure 5. Phase comparison between expected and received phase differences for SMF fiber link with DCF compensation used in the presence of the nonlinear effect.

3.3 OPC-Aided OD8PSK Transmission

The simulation model of the OPC-aided configuration is depicted in Figure 6. In the OPC-based configuration, the inline DCF module for chromatic dispersion compensation is removed, and an OPC-unit is inserted in the middle of the transmission link in order to study the compensation of dispersion and the nonlinear impairments. The components (transmitter, receiver, SSMF, amplifiers, etc.) are the same as in the DCF based configuration discussed in the previous section. To simulate the MSSI technique in Matlab Simulink, we put a block in the middle of the fiber which takes the conjugate of OD8PSK signal (Fig 6).

The wavelength of the conjugate signal ω_c is given by the following relation:

$$\omega_c = 2 \times \omega_p - \omega_s \quad (2)$$

Where ω_s is the wavelength of signal (1550 nm), ω_p is the wavelength of pump (1546.12 nm), i.e. the conjugate signal is propagated in the second part of fiber by a wavelength of 1542.24 nm.

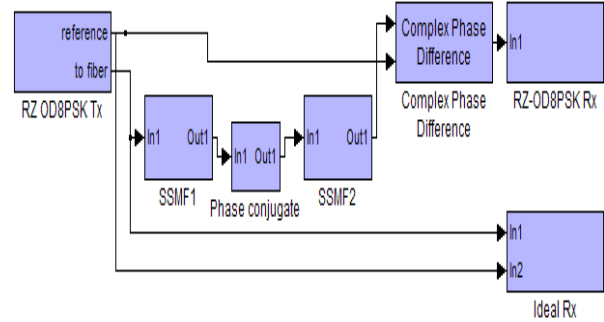

Figure 6. RZ-OD8PSK transmission Simulink optical simulator for single channel transmission with OPC.

Initially, we validate the simulation by this technique for a bit rate of 10Gbit/s and a length of fiber of 80km. Fig.7. show the result after simulation. The phase difference detected resulting by this technique of compensation after propagation is the same one as the phase difference expected (before propagation) as we can observe, which means the absence of any distortion induced by chromatic dispersion and self phase modulation (SPM), that is to say, by this technique we obtain a total compensation of chromatic dispersion and self phase modulation (SPM) through only one device placed in the middle of fiber. As a result, we obtain a good recovery of transmitted data and a cost reduction in an optical system. Also we expect an error-free eye diagram at the receiver.

A total compensation of the self phase modulation also means that all the non linear phase noise (noise of Gordon Mollenauer) is removed.

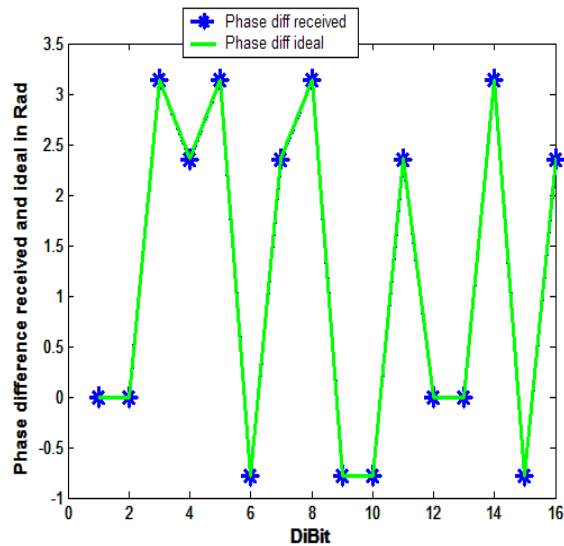

Figure 7. Phase comparison between the expected and received phase differences for SMF fiber link with MSSSI compensation used in the presence of the nonlinear effect.

The great advantage of the use of this technology resides in its implementation (without employing module of compensation (DCF)), which simplify much the design of an optic communication system. As a result we avoid the great losses of the DCF fibers; causing the reduced numbers of the optical amplifiers, and then the cost is lower and the noise ASE is reduced.

We will increase the transmission distance from 80 km to 160 km, with a bit rate of 40 Gbit/s and do a test on our optical communication system. In fact, the experts plan to renew the terrestrial and undersea network systems, so that the bit rate will be by 2010 a 40 Gbit/s.

We examine the eye diagram formed at the output of the receiver model given at 2^4 (256) random bit encoded sequence. We obtain the following eye diagram traces; Fig8 (a) shows the back-to-back eye diagrams of the RZ-OD8PSK signal. Fig. 8(b) and (c) shows the eye diagrams after transmission without and with OPC, respectively. It is clearly seen that the eye diagram in Fig.8(c) is more open because of

compensation between linearity and nonlinearity. It can be seen from the eye-diagram that this technique can compensate the chromatic dispersion and the self phase modulation for a bit rate of more than 10 Gbit/s and a distance of more than 80 km in systems OD8PSK, without the introduction of any other technique of compensation. We understand that the technique OPC (when a periodically poled lithium-niobate (PPLN) waveguide is used [7]) is transparent to the bit rate and to the distance from transmission even in the presence of the nonlinear effects (SPM). This transparency is particularly appealing for network operators since existing networks can be upgraded without having to replace the equipment, or to make changes in the transmission line.

Accordingly, we proved by simulation in Matlab Simulink environment, that an OPC in addition to its effectiveness in the DPSK and DQPSK systems as the reference [7] shows us, it's also able to give good results in the OD8PSK systems. To note that our system is powerful; this is basically an extension of DQPSK where 3 bits per symbol are transmitted, which can lead to higher aggregate capacity for optical transmission, in addition the OD8PSK modulation has a better nonlinear tolerance and increased in spectral efficiency compared to optical differential quaternary phase-shift keying (DQPSK) [3].

Moreover it appears that the tools for simulation are used more and more. They allow savings of time and money by avoiding the iterative experiments on demonstrators of systems.

The model reported here has considered only the transmission fiber, spanning a total length of 160 km. Multi-span long-haul dispersion managed transmission can be extended without difficulty, incorporating EDFA pre-amplifier and booster amplifiers. This work can be extended in the future to simulate dense and super-dense WDM long-

haul transmission systems with the consideration of other non linear effects.

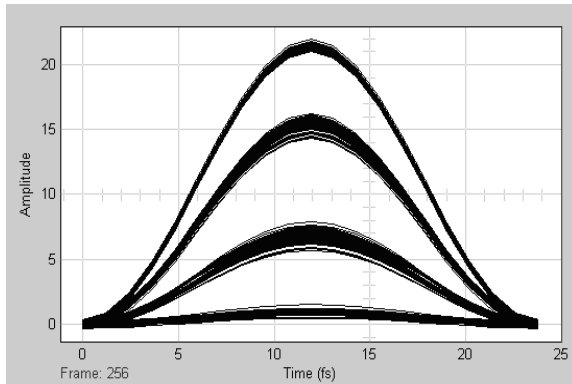

(a)

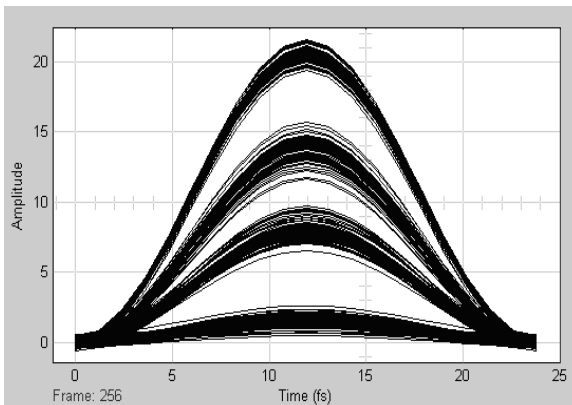

(b)

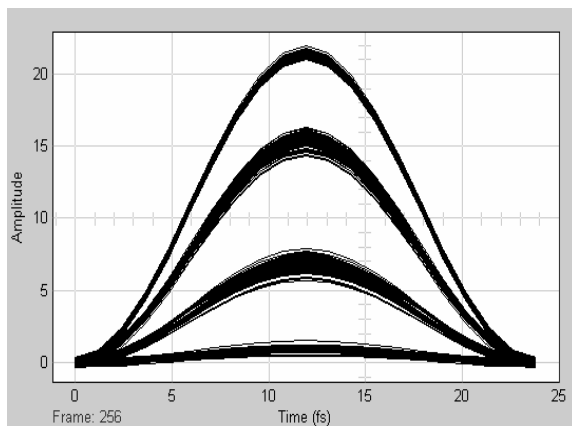

(c)

Figure 8. Eye diagrams of the RZ-OD8PSK signal (a) back-to-back, (b) after transmission without OPC, and (c) with OPC.

4. CONCLUSION

We proved that an MSSI can be used to compensate for the SPM and the chromatic dispersion simultaneously, in the PSK transmission systems. Moreover, the performance of OD8PSK system of 10 Gb/s is compared for MSSI and DCF technique. We also proved that the performance of the arrangement based on fibers DCF is deteriorated by non-linear effect SPM, while the performance of the transmission based on technique MSSI is practically unchanged. This indicates that the non-linear noise of phase is effectively compensated in configuration MSSI. This technique shows also the cost reduction, the transparency with the bit rate and distance from transmission. In addition, These results show that with only one component (MSSI) placed at the middle of fiber, one can avoid the periodic compensation by fibers DCF, which lowers the cost and the obstruction of a system to 10-40Gbit/s of long distance.

References

- [1] C. Xu, X. Liu, and X. Wei, *Differential phase-shift keying for high spectral efficiency optical transmission*, IEEE J. Sel. Topics Quantum Electron., Vol. 10, No. 2, 2004, p. 281-293.
- [2] R. A. Griffin et al., *Optical differential quadrature phase-shift key (DQPSK) for high capacity optical transmission*, in Optical Fiber Communication Conf. Anaheim, CA, 2002, Paper WX6.
- [3] C. Kim and G. Li, *Direct-detection optical differential 8-level phase-shift keying (OD8PSK) for spectrally efficient transmission*, Opt. Express, Vol. 12, 2004, p. 3415-3421.
- [4] A. H. Gnauck et al., *2.5Tbit/s (64x42.7Gb/s) transmission over 40x100km*

- NZDSF using RZ-DPSK format and all-Raman amplified spans*, in proc. OFC'02, FC2, Anaheim, California, 2002.
- [5] C. Kim, G. Goldfarb, Y. Han, Z. Li, X. Li, and G. Li, *WDM transmission over 320 km EDFA-amplified SSMF using 30 Gb/s return-to-zero optical differential 8-level phase-shift keying (OD8PSK)*, Opt. Express, Vol. 13, 2005, p. 4044-4049.
- [6] L.N. Binh, I. Gan and W. Tan, *Simulink Model for Optically Amplified transmission Systems*, Technical Report, (2005, 2006, 2007) Parts I, III, V, IV, Department of Electrical and Computer Systems Engineering, MONASH University, Australia.
- [7] S.L. Jansen, D. van den Borne, B. Spinnler, S. Calabrò, H. Suche, P. M. Krummrich, W. Sohler, G.-D. Khoe, Fellow, and H. de Waardt, *Optical Phase Conjugation for Ultra Long-Haul Phase-Shift-Keyed Transmission*, Journal of Lightwave Technology, Vol. 24, N° 1, January 2006.
- [8] M. Tsang and D. Psaltis, *Dispersion and nonlinearity compensation by spectral phase conjugation*, Opt. Lett., Vol. 28, 2003, p. 1558.
- [9] C. Kim, G. Goldfarb, Y. Han, Z. Li, X. Li, and G. Li, *WDM transmission over 320 km EDFA-amplified SSMF using 30 Gb/s return-to-zero optical differential 8-level phase-shift keying (OD8PSK)*, Opt. Express, vol. 13, 2005, p. 4044-4049.
- [10] Simon Ayotte, Haisheng Rong, Shengbo Xu, Oded Cohen, and Mario J. Paniccia, *Multichannel dispersion compensation using a silicon waveguide-based optical phase conjugator*, OPTICS LETTERS, Vol. 32, N° 16, 2007.
- [11] S.L. Jansen, D. Van den Borne, G. D. Khoe and H. de Waardt, *Compensation of nonlinear phase noise impairments through optical phase conjugation in long-haul transmission systems*, Proceedings Symposium IEEE/LEOS Benelux Chapter, 2005, Mons.
- [12] P.S. Chao et al, *Transmission of 25-Gb/s RZ-DQPSK Signals with 25 GHz Channel Spacing over 1000 Km of SMF-28 Fiber*, IEEE PTL, Vol. 15, 2003, p. 473-475.
- [13] G.P. AGRAWAL, *Light Wave Technology, Telecommunication Systems*, Wiley Inter-Science, 2005, pp. 250-256.
- [14] S.L. Jansen, D. van den Borne, P.M. Krummrich, S. Spalter, G.D. Khoe, and H. de Waardt, *Long-haul DWDM transmission systems employing optical phase conjugation*, J. Lightwave Technol., Vol. 12, 2006, p. 505-520.