

 Open access • Journal Article • DOI:10.1364/OL.17.000908

## High-efficiency continuous surface-relief gratings for two-dimensional array generation. — [Source link](#)

P. Ehbets, Hans Peter Herzig, D. Prongue, Michael T. Gale

**Institutions:** Paul Scherrer Institute

**Published on:** 01 Jul 1992 - Optics Letters (Optical Society of America)

**Topics:** Diffraction efficiency and Lithography

Related papers:

- [Optimized kinoform structures for highly efficient fan-out elements](#)
- [High-efficiency in-line multiple imaging by means of multiple phase holograms](#)
- [Design and fabrication of highly efficient fan-out elements](#)
- [Fabrication of kinoform structures for optical computing](#)
- [Multilevel grating array illuminators manufactured by electron-beam lithography](#)

Share this paper:    

View more about this paper here: <https://typeset.io/papers/high-efficiency-continuous-surface-relief-gratings-for-two-1xe5fhbfqc>

# High-efficiency continuous surface-relief gratings for two-dimensional array generation

P. Ehbets, H. P. Herzig, and D. Prongué

*Institute of Microtechnology, University of Neuchâtel, Rue A.-L. Breguet 2, CH-2000 Neuchâtel, Switzerland*

M. T. Gale

*Paul Scherrer Institute, Badenerstrasse 569, CH-8048 Zürich, Switzerland*

Continuous surface-relief phase gratings for two-dimensional (2-D) array generation have been realized by laser-beam writing lithography. For a  $9 \times 9$  fan-out element, a diffraction efficiency of 94% and a uniformity of better than  $\pm 8\%$  have been achieved. These are, to our knowledge, the best published results for 2-D surface-relief fan-out elements. Separable and nonseparable solutions for the design of 2-D fan-out elements are discussed.

Space-invariant fan-out elements split a single laser beam into quasi plane waves, which are focused by a lens as shown in Fig. 1. Such phase gratings that generate arrays of light spots are widely used in parallel processing systems.

In order to realize highly efficient fan-out elements, recent efforts have concentrated on multilevel phase structures<sup>1</sup> and continuous phase profiles.<sup>2</sup> The fabrication of multilevel phase structures involves microlithographic technologies that are well mastered and widely available. The drawback of this approach is that the number of masks increases with the number of phase levels. Thus precise alignment has to be performed at each process. Continuous phase profiles are recognized as providing the highest diffraction efficiency. On the other hand, their fabrication is considerably more challenging.<sup>3</sup>

In this Letter we report on a successful implementation of the optimized continuous phase function for a two-dimensional (2-D) fan-out element as a continuous surface-relief grating in photoresist. The fabrication was possible by using the laser-beam writing system developed at the Paul Scherrer Institute in Zürich<sup>4</sup> (PSIZ). The advantage of this technology is that the structure is written in one single step, thus errors due to successive alignments are avoided.

The optimization used for the design of one-dimensional (1-D) fan-out elements is described in detail in Ref. 5. In this Letter the theory is generalized for 2-D design. The optimization process consists of two basic steps: the first leads to high efficiency, and the second yields perfect uniformity of the generated array of light spots with only a slight decrease in efficiency. One of the basic questions of optimizing continuous phase profiles is the relevant parameter set to describe the continuous surface relief. Contrary to the optimization of multilevel phase gratings,<sup>1</sup> we describe the fan-out

elements by the array of spots that appear in the Fourier plane. This approach defines a minimum set of parameters for the exact representation of the continuous surface relief. The parameters to be optimized are the amplitudes and phases of an array of point sources. The desired field distribution in the back focal plane of the lens (Fig. 1) can be written as

$$U(x, y) = \sum_{m=1}^M \sum_{n=1}^N A_{mn} \exp(i\phi_{mn}) \delta(x - x_m, y - y_n), \quad (1)$$

where  $A_{mn}$  is the amplitude,  $\phi_{mn}$  is the phase, and  $(x_m, y_n)$  is the position of the  $m, n$ th spot of a 2-D array. As we are only interested in the intensity distribution of the object, the phases  $\phi_{mn}$  are free parameters.

The field distribution  $\hat{U}(u, v)$  in the grating plane is related to the field  $U(x, y)$  by a Fourier transform (FT):

$$\hat{U}(u, v) = |\hat{U}(u, v)| \exp[i\Psi(u, v)] = \text{FT}\{U(x, y)\}, \quad (2)$$

where  $|\hat{U}(u, v)|$  is the magnitude and  $\Psi(u, v)$  is the phase of the field distribution in the grating plane. The irradiance distribution  $I(u, v)$  in the grating

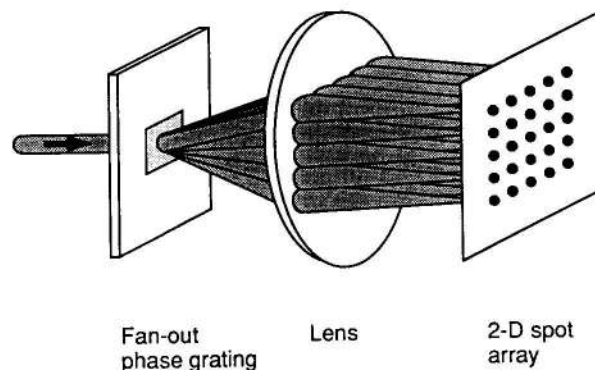

Fig. 1. Readout of the fan-out element.

plane can then be written as

$$\begin{aligned}
 I(u,v) &= |\hat{U}(u,v)|^2 \\
 &= \sum_{mn} A_{mn}^2 + 2 \sum_{m < m'} \sum_{n < n'} A_{mn} A_{m'n'} \\
 &\quad \times \cos\{2\pi[u(x_m - x_{m'}) \\
 &\quad + v(y_n - y_{n'})] + \phi_{mn} - \phi_{m'n'}\}, \quad (3)
 \end{aligned}$$

where the first term on the right-hand side of Eq. (3) is constant and equal to the mean object irradiance. The second term describes the variations of the irradiance. These intermodulations are due to interference between the object waves in the grating plane.

To reproduce the desired object  $U(x, y)$  perfectly, the hologram must have a transfer function proportional to  $\hat{U}(u, v)$ , which means an intensity transfer function proportional to  $I(u, v)$  and a phase transfer function equal to  $\exp[i\Psi(u, v)]$ . With a single element, the intensity transfer function can be realized only by absorption. In order to minimize the losses due to the required intensity transfer function, the variations of the object irradiance in the hologram plane have to be minimized. Therefore the optimization criterion can be formulated as

$$\iint [I(u, v) - \langle I \rangle]^2 du dv \rightarrow \min. \quad (4)$$

The variables of the optimization are the phases  $\phi_{mn}$  of the point sources, given in Eq. (1), while the amplitudes of the point sources for a uniform fan-out are all equal ( $A_{mn} = 1$ ). The optimization problem is solved by applying a downhill simplex algorithm. The optimization criterion (4) reduces the intermodulation terms of Eq. (3) to a minimum. The residual intermodulation still causes some absorption. In order to reach the highest diffraction efficiency, we opt for a pure phase element and clip the residual intensity transfer function to  $I(u, v) = 1$ . Clipping the residual intermodulation terms hardly alters the high efficiency but reduces the uniformity of the fan-out. In order to improve the uniformity of the fan-out, we use an additional optimization process. By iteratively changing the amplitudes of the initial point sources  $A_{mn}$  slightly to  $A_{mn}^{(i)}$ , where  $i$  counts the number of iteration loops, the resulting amplitudes of the output can be perfectly balanced. This second optimization decreases only slightly the optimized diffraction efficiency from step one. The substitution of the optimum set of phases  $\phi_{mn}$  and the new amplitudes  $A_{mn}^{(i)}$  into Eqs. (1) and (2) defines the optimized phase function  $\Psi(u, v)$  of the fan-out element, which generates a perfectly uniform array of spots. This phase function is implemented as a continuous surface-relief element without quantization.

In order to reduce the computing time, separable solutions are attractive for generating large  $M \times N$  arrays. In this case the object is described by  $U(x, y) = F_1(x)F_2(y)$ . Thus only the 1-D problem, as described in Ref. 5, has to be solved. On the other hand, if the 1-D solution of an  $N \times 1$  array yields a diffraction efficiency of  $\eta$ , the corresponding 2-D solution of the  $N \times N$  array will be less efficient, namely,  $\eta^2$ . Since 2-D nonseparable solutions have more free parameters for the optimization, the minimum intermodulations of the irradiance distribution will be smaller than for the separable solution. We have found for a  $3 \times 3$  array a theoretical efficiency of 85.7% for the separable solution and 93.9% for the nonseparable solution. For a  $5 \times 5$  array the efficiency was calculated to be 84.8% for the separable solution and 93.0% for the nonseparable solution.

The  $9 \times 9$  fan-out element has the best performance. In this case, we have found for the separable solution as well as for the nonseparable solution the same diffraction efficiency. Theoretically this element has an efficiency of 98.6% and perfect uniformity. We have realized the separable solution, which is symmetric for all axes of the array. The 2-D solution is obtained by crossing two 1-D solutions. The phase distribution of the 1-D optimum phase profile is then described by nine point sources with amplitudes  $A_i$  and phases  $\phi_i$ . The numerical values are given in Table 1. The amplitudes and phases of the optimum point sources for the 2-D solution are then determined by  $A_{mn} = A_m A_n$  and  $\phi_{mn} = \phi_m + \phi_n$ , where  $m, n = 1 \dots 9$ . One unit cell of the optimized phase profile for the  $9 \times 9$  fan-out element is shown in Fig. 2.

The optimized phase function for the  $9 \times 9$  fan-out element was realized in photoresist with the laser-beam writing system at the PSIZ, which results in a continuous surface-relief element. A complete description of the laser writing system at the PSIZ can be found in Ref. 4. This system uses  $x$ - $y$  scanning and is therefore well suited for the fabrication of periodic 1-D and 2-D diffractive optical elements, such as kinoforms. The resist-coated substrate is mounted on a precision air-bearing  $x$ - $y$  translation table and scanned under a modulated focused laser beam. The writing light source is a HeCd laser operating at a wavelength of 442 nm. The beam intensity is computer controlled by an acousto-optic modulator, which is synchronous with the raster scan movement. The exposure data are computed from the desired microrelief and the measured (non-linear) resist development characteristics. Development of the resist then results in a microrelief of the desired structure. We have used Shipley AZ 1400 resist and AZ 303 developer, diluted 1:7, to obtain a

**Table 1. Optimum Amplitudes  $A_i$  and Phases  $\phi_i$  for the Nine-Beam Fan-out ( $i = 1 \dots 9$ )**

	$A_i$								
	1.059	0.957	0.987	0.998	1.022	0.998	0.987	0.957	1.059
$\phi_i$ (rad)	1.772	0.135	3.887	2.455	3.142	2.455	3.887	0.135	1.772

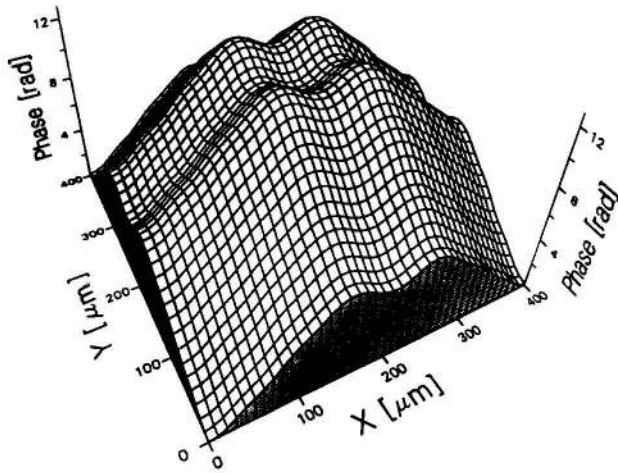

Fig. 2. One period of the optimized phase profile for a  $9 \times 9$  fan-out element.

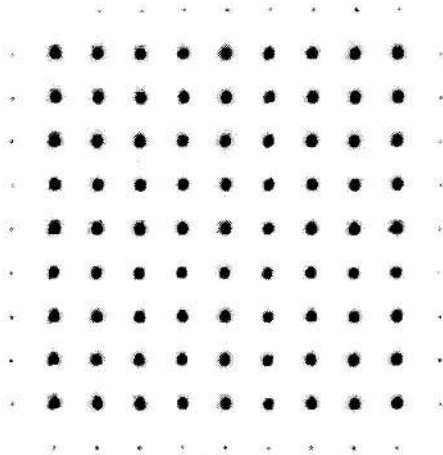

Fig. 3.  $9 \times 9$  array of generated spots.

relatively linear dependence of the developed micro-relief on the local exposure.

The spot size of the writing beam and the spacing of the raster lines are chosen according to the structure size of the microrelief. As our fan-out element has a slowly varying phase function (Fig. 2), a relatively large spot size can be used. This, together with a sufficient overlap of the raster scan,<sup>6</sup> reduces the sensitivity of the laser writing system to vibrations and therefore improves the quality of the relief surface. A spot size of  $8 \mu\text{m}$  ( $1/e$  intensity points) and a raster line space of  $2 \mu\text{m}$  have been used for the fabrication. The periodicity of the  $9 \times 9$  fan-out element was chosen to be  $400 \mu\text{m}$ . One unit cell of the optimized phase function was represented by  $200 \times 200$  pixels. The phase data were then converted into resist thickness values, with a reconstruction wavelength of  $\lambda = 488 \text{ nm}$  and a refractive index of the resist at this wavelength of  $n = 1.64$ . These parameters determine the maximum modulation depth of the surface-relief grating to be  $1.55 \mu\text{m}$ .

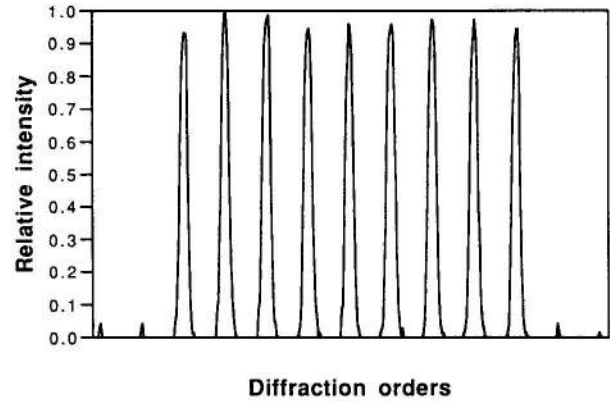

Fig. 4. Measured intensity profile of the central row.

For the reconstruction, the  $9 \times 9$  fan-out element was illuminated by a collimated argon-ion laser beam. The generated spot array was evaluated by using a CCD camera. The experimental results show an efficiency of 94% (relative to the total transmitted light) and a uniformity error within  $\pm 8\%$  of the average diffracted beam power for the whole  $9 \times 9$  array. Within one line or one row the uniformity is better than  $\pm 5\%$ . Figure 3 shows the generated  $9 \times 9$  pattern of light spots in the back focal plane of the lens (see Fig. 1), and Fig. 4 shows the intensity profile of the central row, which also contains the zero order. Once a master microrelief has been fabricated in photoresist, it can be reproduced by modern replication technology. Casting or embossing from a metal shim enables the fabrication of a large number of high-quality replicas. Such replicas are currently being fabricated.

We have shown that high-quality fan-out elements can be realized as continuous surface-relief gratings. The laser-beam writing system permits the fabrication of accurate master microreliefs in a photoresist that are suitable for further replication. The diffraction efficiency of 94% and uniformity of better than  $\pm 8\%$  over the whole  $9 \times 9$  array are, to our knowledge, the best results so far published for 2-D surface-relief fan-out elements.

## References

1. J. Turunen, J. Fagerholm, A. Vasara, and M. R. Taghizadeh, *J. Opt. Soc. Am. A* **7**, 1202 (1990).
2. H. P. Herzig, D. Prongué, and R. Dändliker, *Jpn. J. Appl. Phys.* **29**, L1307 (1990).
3. D. Daly, S. M. Hodson, and M. C. Hutley, *Opt. Commun.* **82**, 183 (1991).
4. M. T. Gale, G. K. Lang, J. M. Raynor, H. Schütz, and D. Prongué, "Fabrication of kinoform structures for optical computing," *Appl. Opt.* (to be published).
5. D. Prongué, H. P. Herzig, R. Dändliker, and M. T. Gale, "Optimized kinoform structures for highly efficient fan-out elements," *Appl. Opt.* (to be published).
6. M. T. Gale and K. Knop, *Proc. Soc. Photo-Opt. Instrum. Eng.* **308**, 347 (1983).