

High Efficiency Power Amplifier for High Frequency Radio Transmitters

M.Vasić, O. García, J.A. Oliver, P. Alou, D. Diaz, J.A. Cobos
 Centro de Electrónica Industrial (CEI)
 Universidad Politécnica de Madrid
 Madrid, Spain
 miroslav.vasic@upm.es

A.Gimeno, J.M.Pardo, C.Benavente, F.J.Ortega
 Radio Engineering Group (GIRA)
 Universidad Politécnica de Madrid
 Madrid, Spain

Abstract— Modern transmitters usually have to amplify and transmit complex communication signals with simultaneous envelope and phase modulation. Due to this property of the transmitted signal, linear power amplifiers (class A, B or AB) are usually employed as a solution for the power amplifier stage. These amplifiers have high linearity, but suffer from low efficiency when the transmitted signal has high peak-to-average power ratio. The Kahn envelope elimination and restoration (EER) technique is used to enhance efficiency of RF transmitters, by combining highly efficient, nonlinear RF amplifier (class D or E) with a highly efficient envelope amplifier in order to obtain linear and highly efficient RF amplifier. This paper presents solutions for the power supply that acts as the envelope amplifier and class E amplifier that is used as a nonlinear amplifier. The envelope amplifier is implemented as a multilevel converter in series with a linear regulator and can provide up to 100 W of peak power and reproduce sine wave of 2 MHz, while the implemented class E amplifier operates at 120 MHz with an efficiency near to 90%. The envelope amplifier and class E amplifier have been integrated in order to implement the Kahn's technique transmitter and series of experiments have been conducted in order to characterize the implemented transmitter.

I. INTRODUCTION

In the modern radio communication systems high efficiency and high linearity are the essential requirements for the employed power amplifiers. High linearity is needed due to complex modulation techniques where phase and amplitude modulations are applied simultaneously in order to transmit as much data as possible for the given bandwidth, while the high efficiency improves thermal management, reliability and cost. Due to the need of high linearity, linear power amplifiers (classes A, B or AB) are usually used, but this leads to low average efficiency of the power amplifier, especially when signals with high Peak to Average Power Ratio (PAPR) are transmitted [1]. In [2] is explained that class A and class B amplifiers have efficiency of 5% and 28% respectively if a signal with a Rayleigh's distribution is transmitted.

One of the techniques that offer high efficiency and high linearity is the Kahn's technique or Envelope Elimination and Restoration (EER) technique [3]. This method proposes linearization of highly efficient, but nonlinear power amplifier (class E or D) by modulation of its supply voltage. The modulation of the supply voltage is done through an envelope amplifier according to the reference signal that is proportional to the envelope of the transmitted signal, while the phase modulation of the transmitted signal is conducted through the nonlinear amplifier. The basis for EER is the equivalence of any narrowband signal to simultaneous amplitude (envelope) and phase modulation:

$$V_{RF}(t) = I(t) \cos(2\pi ft) - Q(t) \sin(2\pi ft) = A(t) \cos(2\pi ft + \theta(t)) \quad (1)$$

$$\theta(t) = \arctg\left(\frac{Q(t)}{I(t)}\right) \quad A(t) = \sqrt{I(t)^2 + Q(t)^2} \quad (2)$$

where f is the carrier frequency, $Q(t)$ and $I(t)$ are modulated signals. The block scheme of an EER system is shown in Figure 1.

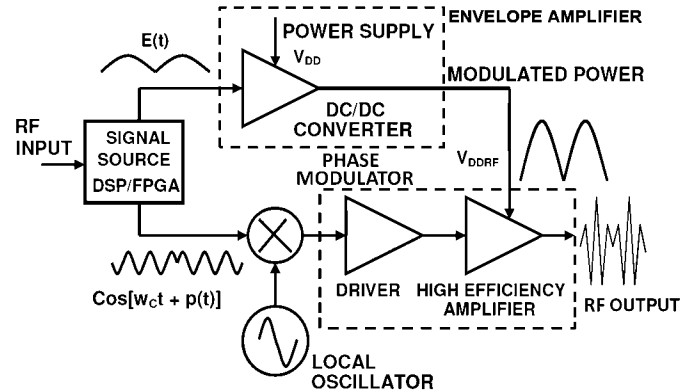

Figure 1. Block Scheme of Kahn Technique Transmitter

Thanks to this technique, the efficiency of the transmitter is almost constant for wide load range and it does not depend heavily on the level of the transmitted signal, as in the case of linear amplifiers [4]. Average efficiency three to five times those of linear amplifiers have been demonstrated from HF to L band [5,6]. In [7] a prototype of Kahn's transmitter for HF Band is presented. Its output power was about 50 W and its overall efficiency was up to 15% better than the efficiency of the conventional linear power amplifier.

In this paper solutions for the power supply that acts as the envelope amplifier and class E amplifier that is used as a non-linear amplifier are presented. The envelope amplifier is based on a multilevel converter in series with a linear regulator and its bandwidth is in range of 2 MHz, while the class E amplifier operates at 120 MHz. The instantaneous output power provided by the class E power amplifier is in range of 90 W. The proposed solutions for the envelope amplifier and class E amplifier are integrated into an EER transmitter and series of tests have been conducted in order to characterize the transmitter

II. ENVELOPER AMPLIFIER

Due to high bandwidth requirements, conventional solutions for tracking power supplies [8-10] are not energy efficient. The envelope amplifier that will be used consists of a multilevel converter and a linear regulator in series, [11]. Its block schematic is shown in Figure 2. The multilevel converter has to supply the linear regulator and it has to provide discrete voltage levels that are as close as possible to the output voltage of the envelope amplifier. If this is fulfilled, the power losses on the linear regulator will be minimal, because they are directly proportional to the difference of its input and output voltage. However, in order to guarantee correct work of the linear regulator, the output voltage of the multilevel converter has to be higher than the output voltage of the linear regulator. Time diagrams of the multilevel and linear regulator voltage are shown in Figure 3

The efficiency of the linear regulator depends on the number of the voltage levels that are used to supply it and on their distribution as well. Usually, the transmitted signal has high Peak to Average Power Ratio (PAPR), and it can be described by its probability density function [4]. Using the information about the signals probability the efficiency of the linear regulator can be presented as:

$$\eta = \int_0^{V_{max}} \frac{a}{V_{in}(a)} p(a) da \quad (3)$$

where a is the voltage level of the generated envelope (the output voltage of the linear regulator), V_{max} is the maximum value of the signal's envelope, $V_{in}(a)$ is the linear regulator's input voltage generated by the multilevel converter that depends on the value of the linear regulator's output voltage and $p(a)$ is the probability density function of the envelope that is generated by the power supply. By optimizing the voltage levels of the multilevel converter in order to maximize average efficiency of the linear regulator, it is possible to enhance its average efficiency up to 6% comparing it with the solution that employ equidistant voltage levels [11].

In [11] several solutions for the multilevel converter are proposed. The schematic of the envelope amplifier that will be integrated with class E amplifier can be seen in Figure 4. There are three stages that can be distinguished in the proposed solution:

- single input multiple output converter (a flyback converter in our case)
- multilevel converter based on two-level independent voltage cells
- high slew rate linear regulator

The task of the flyback converter is to provide stable voltages that will supply two-level voltage cells. The bandwidth of this stage does not have to be high; therefore, the switching frequency of the multiple-outputs flyback can be very low in order to increase its efficiency. In the case of the prototype in this paper, flyback's switching frequency was only 50 kHz.

The switching frequency of the MOSFETs that are inside the two-level cells will depend on the signal that is reproduced. If the signal is a sine wave of 1 MHz, the switching frequency of the multilevel converter is 1MHz as well. Therefore, with this topology high frequency signals can be reproduced by applying the switching frequency equal to the frequency of the signal, instead of several times higher, like in the case of PWM converters.

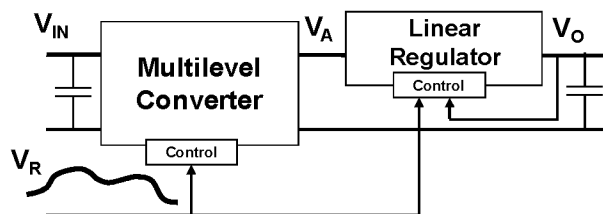

Figure 2. Simplified schematic of the proposed envelope amplifier

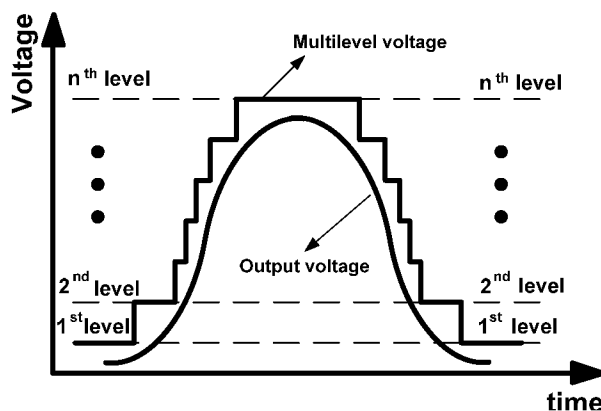

Figure 3. Time diagrams of the proposed envelope amplifier

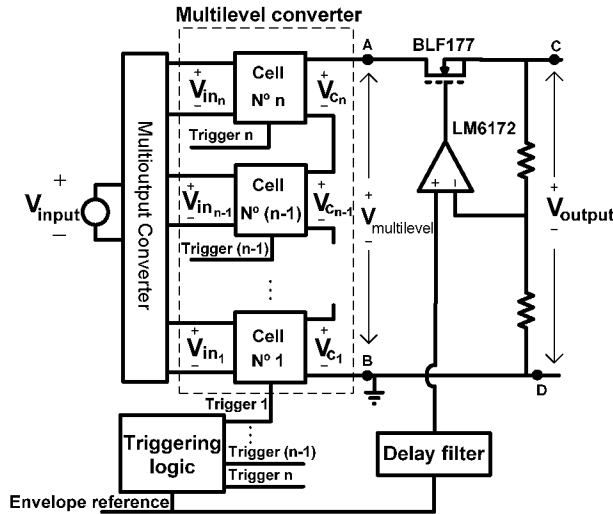

Figure 4. Simplified schematic of the implemented envelope amplifier

An envelope amplifier with the following specifications has been built:

- Variable output voltage from 0 V to 23 V
- The maximum instantaneous power is 50 W
- The maximum frequency of the reference signal is 2 MHz
- The multilevel converter is made with three optimized voltage levels (12 V, 18 V and 24 V)

The output voltages of the multilevel converter are selected by maximizing equation 3, while the MOSFET for the pass element and operational amplifier in the linear regulator have been selected in the way to obtain high bandwidth of the envelope amplifier. The bandwidth of the selected operational amplifier (LM6172) is 100 MHz in open loop, while the MOSFET (BLF177) is from HF/VHF power MOS family of transistors. The output voltages of the envelope amplifier and the multilevel converter in the case when a 2 MHz sine wave is reproduced are shown in Figure 5.

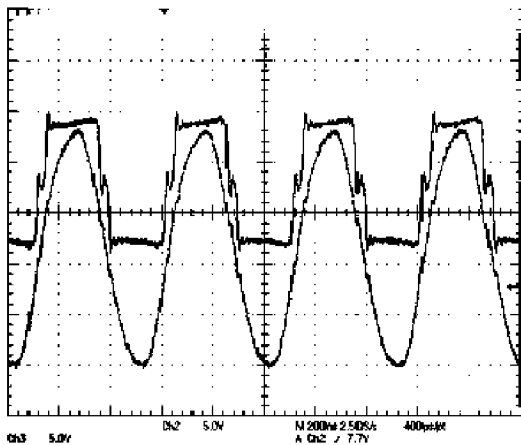

Figure 5. Output voltage of the multilevel converter and envelope amplifier when a 2MHz sine wave is reproduced

TABLE I. MEASURED EFFICIENCY OF THE IMPLEMENTED ENVELOPE AMPLIFIER FOR DIFFERENT SINE WAVES COMPARED WITH THE THEORETICAL EFFICIENCY OF AN IDEAL LINEAR REGULATOR SUPPLIED BY 23 V

| Vsin(V) | Sine wave frequency (MHz) | Measured efficiency of the envelope amplifier based on the independent switching cells | Theoretical efficiency of an ideal linear regulator supplied by 23V |
|---------|---------------------------|--|---|
| 0-9 | 2 | 44.1% | 29.3% |
| 5-14 | 2 | 56.8% | 45.9% |
| 0-22.5 | 2 | 70.2% | 73.4% |
| 0-9 | 0.5 | 43.6% | 29.3% |
| 5-14 | 0.5 | 59.5% | 45.9% |
| 0-22.5 | 0.5 | 71.2% | 73.4% |

The efficiency of the prototype is measured for different sine waves and the results are summarized in Table 1. The efficiency is shown depending on the frequency of the reproduced sine wave and its DC offset and amplitude. The measured efficiency is compared with the efficiency of an ideal linear regulator and, as it can be seen, the efficiency of the hybrid solution is almost 50% higher than the efficiency of an ideal linear amplifier when a transmitted signal has low average values, and that is mostly the case when the EER technique is applied.

III. CLASS E AMPLIFIER

The class E amplifier that is used to amplify the constant envelope, phase modulated, component of the signal, operates at the VHF band and exhibit wide fractional bandwidth (from 95 MHz to 120 MHz). The drain to source voltage of the implemented class E amplifier can be seen in Figure 6 at 120 MHz showing the amplifier is operating near nominal Class-E conditions.

The design of the amplifier and its load network has been optimized to reduce power losses to a minimum. The results of efficiency measurements are shown in Figure 7. When the class E amplifier is supplied with constant voltage of 24 V, its output power exhibits a peak value of 90 W operating between 100MHz and 110MHz. The drain efficiency of the amplifier in that frequency range is around 92% (A Bird 5000EX wattmeter has been used to measure output power, the accuracy of this instrument is 5%).

The driver of the amplifier has been specially designed to reduce driving power as much as possible. It is based on using an additional Class-E amplifier at the input of the main amplifier. This driver uses the drain voltage of its RF power MOSFET to charge and discharge the gate of the main power MOSFET. Implemented in this way, the driver shows significant improvement in efficiency comparing it to the conventional driving solutions using sine waves to drive RF power MOSFET into switching conditions.

The RF power MOSFET used with this amplifier is a MRF6V2300N from Freescale Semiconductors. Input and output ports have been modeled for switching operation using the model proposed in [12].

This amplifier has been designed based upon the load impedance synthesis design technique as shown in [13] and

simulated and optimized using Advanced Design System (ADS) software from Agilent.

IV. INTEGRATION OF THE ENVELOPE AMPLIFIER WITH CLASS E AMPLIFIER

In order to obtain high linearity of an EER transmitter, it is necessary that the envelope injection produced by the envelope amplifier is synchronized with phase modulated signal component amplified by the E amplifier and that the envelope amplifier is highly linear. For the sake of simplicity, the linearity tests of the envelope amplifier are conducted by two-tone tests, where two sine waves of the same amplitude are used as a test signal and at the output of the envelope amplifier the ratio between the desired components and the intermodulation products that are produced by the envelope amplifier is observed. Figure 8 presents the output voltage of the multilevel converter and the envelope amplifier's output voltage during a two tone test. Measurements of the attenuation of the intermodulation products show that the attenuation is higher than 50 dB, which means that the system exhibits high linearity Figure 9.

In [1] it has been explained that the bandwidth of the envelope amplifier has to be, at least, two times higher than the bandwidth of the RF signal. The reproduced envelope should not have any attenuation up to 2 MHz and it has been shown that the proposed envelope amplifier can reproduce 2 MHz sine wave of maximum amplitude. However, this does not mean that the implemented envelope amplifier cannot reproduce signals of wider bandwidth. The higher harmonics that are very important for high linearity of Kahn's transmitter usually are of much smaller amplitudes than the maximum amplitude that can be reproduced by the envelope amplifier. Based on the analysis presented in [1], a test with rectified sine wave has been conducted. If the reference signal is a rectified sine wave of frequency f , its spectrum is infinite and consists of tones that are placed on frequencies $2f, 4f, 6f...$ A rectified 500 kHz sine wave of maximum amplitude has been used as the reference and the response of the envelope amplifier has been measured, Figure 10. The spectrum of the output signal is compared with the spectrum of the reference signal, Figure 11. It can be seen that the proposed envelope amplifier admits even the harmonic higher than 2 MHz.

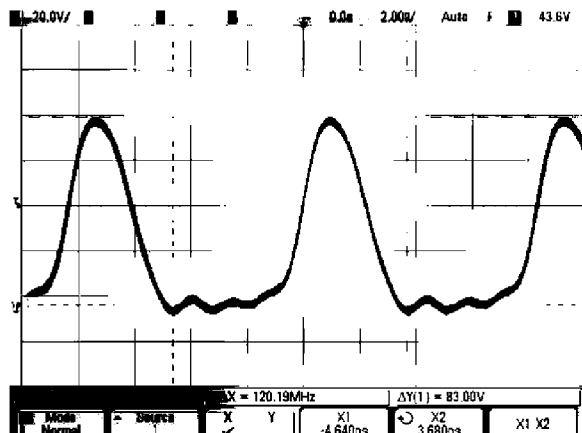

Figure 6. Drain voltage of the implemented class E amplifier when it operates at 120MHz

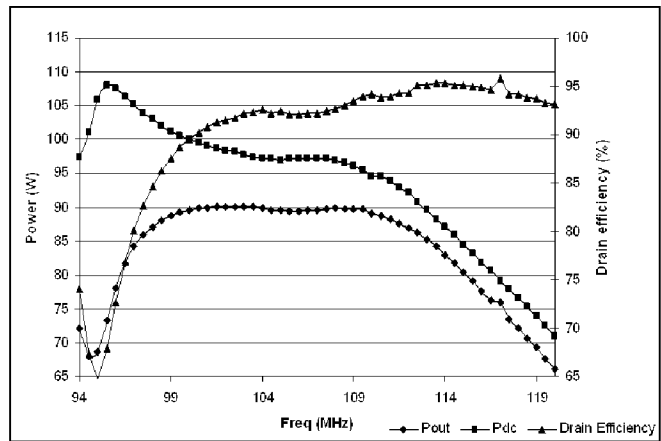

Figure 7. Measured output power and the efficiency of the implemented class E for different switching frequencies (instrument accuracy: 5%).

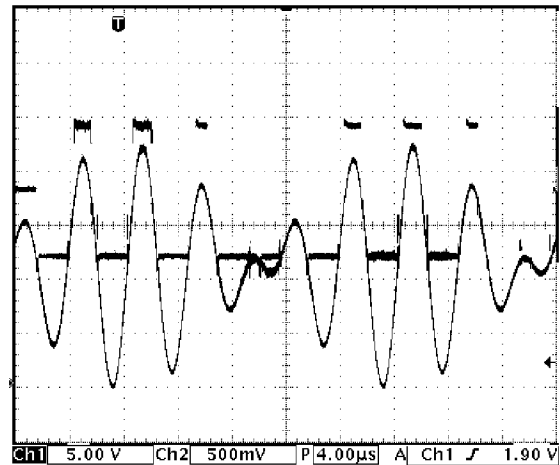

Figure 8. Output voltage of the multilevel converter and envelope amplifier when a two tone test is performed. Two tone signal consists of two sine waves of 200 kHz and 250kHz

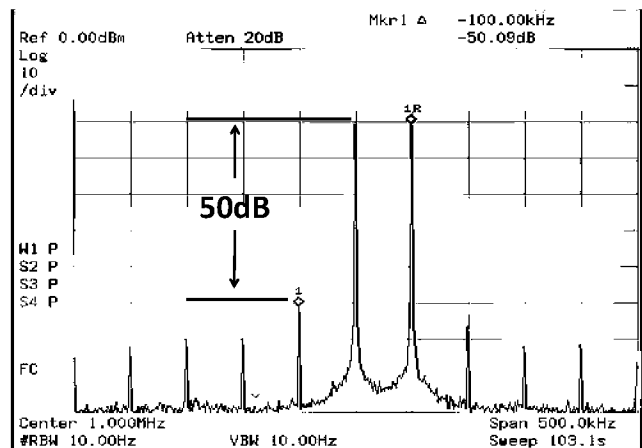

Figure 9. Attenuation of the intermodulation components measured by a spectral analyzer in the two tone test, when a sine waves of 1 MHz and 1.05 MHz are used.

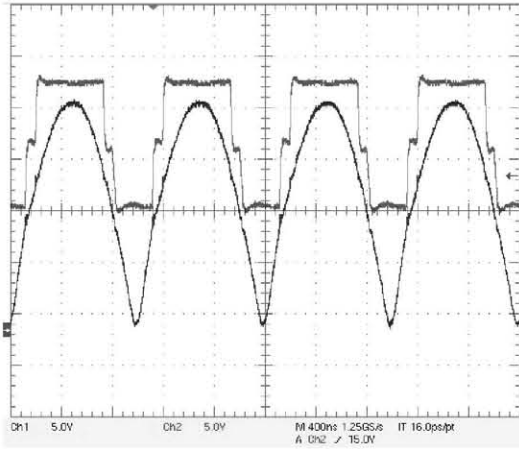

Figure 10. Waveform of multilevel's output voltage and linear regulator's output voltage when a rectified 500 kHz sine wave is used as the reference

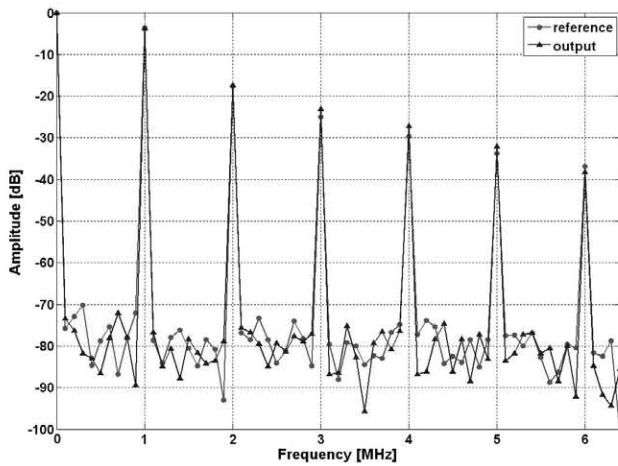

Figure 11. Spectrum of the reference and output signal when a rectified 500kHz sine wave is used as the reference. All the values are scaled to the dc value of the signal

One of the problems that can occur is that the high frequency signal amplified by the class E amplifier goes back towards the envelope amplifier. Due to this problem, the envelope amplifier supplies the class E amplifier through simple LC filter, which has been designed in the way that there is not attenuation up to 2 MHz (i.e. up to the desired bandwidth of the envelope amplifier). In the case of our design, the values of the inductance and capacitance are 200 nH and 10 nF respectively.

Besides the envelope amplifier and class E amplifier, the implemented transmitter has a part that is used to receive reference signal and than to generate needed phase and envelope references. This part consists of a FPGA Virtex 4 development board fitted with D/A and A/D converters. In this way, the transmitter can receive the RF reference signal through A/D converters, and the envelope and phase references are extracted inside a FPGA. The digitalized references are converted to analog signals using high speed D/A converters, and sent to envelope and class E amplifiers. Additionally, two delay filters and the envelope's amplifier triggering logic are implemented in the employed FPGA. The

first delay filter is used in order to synchronize the envelope reference signal sent to the linear regulator with the output voltage of the multilevel converter and its aim is to avoid the distortion of the reproduce envelope. In [1] it has been shown that the differential delay between the produced envelope and phase modulation should not be higher than one tenth of the bandwidth of the RF signal. The second delay filter is used to adjust the differential delay in order to obtain high overall linearity of the system. The triggering logic needed by the multilevel converter is a simple set of comparators that has to regulate the state of the voltage cells.

Figure 12 shows the implemented EER transmitter.

V. EXPERIMENTAL RESULTS

The first tests with the implemented EER transmitter have been conducted in open loop in order to characterize it. The simplest test is the one when only the amplitude modulation is performed. Figure 13 shows the relevant time diagrams when the envelope reference is 500 kHz sine wave. It can be seen the envelope reference is noisy due to the RF signal that is present in the class E amplifier. However, this noise does not have big influence on the envelope amplifier because its frequency is much higher than its bandwidth and, in that way, it is filtered. Another important fact is that every time when there is a change of the multilevel's output voltage, there is a small glitch in the output voltage of the envelope amplifier. These glitches are the consequence of the finite bandwidth of the implemented linear regulator. The higher the current of the envelope amplifier is, the bigger are the glitches. Fortunately, thanks to the LC filter that is placed between the envelope amplifier and the class E amplifier, these glitches are negligible after the envelope amplifier's output voltage is filtered.

Figure 14 shows the relevant waveforms when a 2 MHz sine wave is used as the envelope reference. It can be observed that the glitches in supply voltage of the class E converter are negligible. The supply voltage of the class E converter is delayed compared to the envelope amplifier's output voltage due to the employed LC filter.

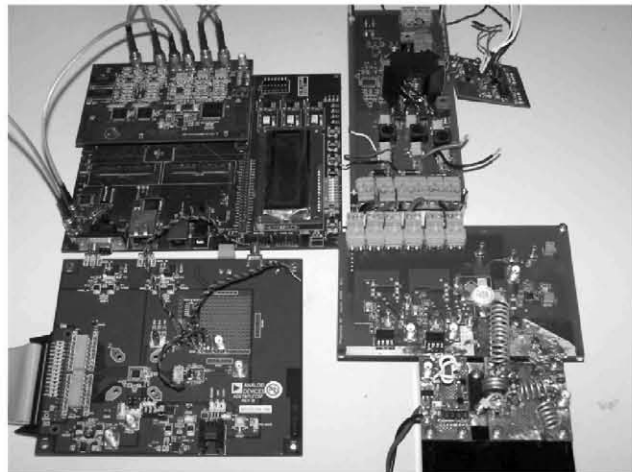

Figure 12. Photograph of the implemented EER Transmitter (on the right) with FPGA board, A/D and D/A converters (on the left)

The transmitter's linearity when only the amplitude modulation is performed is measured as well. Figure 15 shows important oscilloscope waveforms in the case when the envelope reference is composed of 100 kHz and 150 kHz sine waves. The measured attenuation of the third order harmonic was about 30 dB.

In order to measure the linearity of the complete EER transmitter a simple double-sideband suppressed-carrier (DSB-SC) transmission is performed, like in [1]. The carrier frequency is 125 MHz, while the modulated signal is 100 kHz sine wave. This corresponds to the reference that is composed of two tones, 124.9 MHz and 125.1 MHz respectively. The envelope reference is a rectified sine wave, while the phase changes for 180 degrees every time when the envelope reaches zero. Figure 16 shows the oscilloscope waveforms for this test. High frequency noise in the envelope reference can be clearly observed, and it can be seen that it is filtered by the linear regulator due to its finite bandwidth.

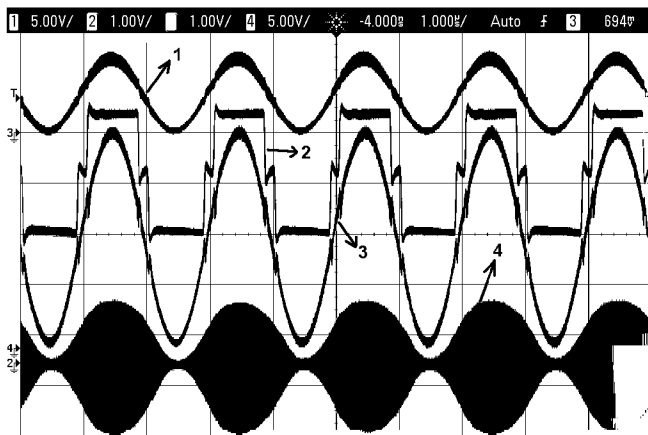

Figure 13. Oscilloscope waveforms of the envelope reference (label 1), multilevel's output voltage (label 2), envelope's amplifier output (label 3) and the EER transmitter's output (label 4), when the envelope reference is a 500 kHz sinewave

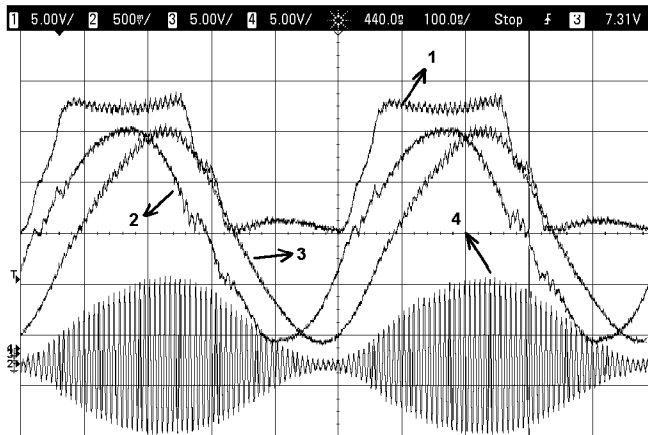

Figure 14. Oscilloscope waveforms of the multilevel's output (label 1), envelope amplifier's output (label 2), supply voltage of the class E amplifier (label 3) and the output of the implemented EER transmitter (label 4) when the envelope reference is a 2 MHz sine wave

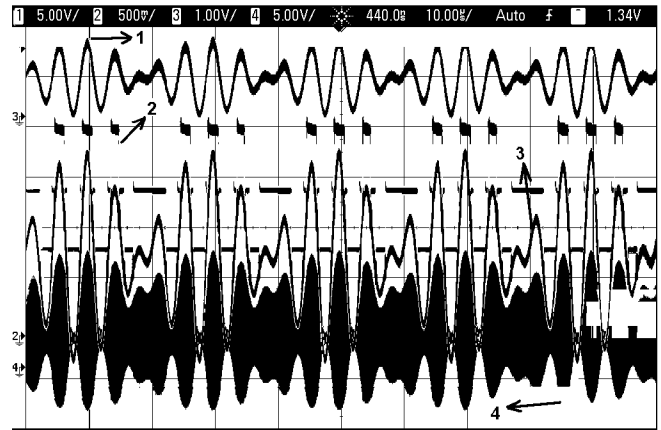

Figure 15. Oscilloscope waveforms of the envelope reference (label 1), multilevel's output voltage (label 2), envelope amplifier's output voltage (label 3) and the output of the implemented EER transmitter (label 4) when the reference signal is composed of two tones (200 kHz and 250 kHz)

The rectified sine wave has frequency of 200 kHz and the spectrum of the output signal is shown in Figure 17. It can be seen that the attenuation of the third harmonic is just 18 dB. The reason for such a small attenuation, although the envelope and phase modulation are synchronized is parasitic AM-PM modulation. The work in order to resolve this issue is in progress.

The last tests were conducted in order to measure the efficiency of the implemented EER transmitter. The efficiency is measured in the case when only amplitude modulation is performed, and the envelope reference is a sine wave. The sine wave reference has different amplitudes, average values and frequencies. One set of efficiency measurements have been performed in order to validate the proposed solution for the envelope amplifier with the efficiency of the system if the envelope amplifier were a linear regulator with constant supply voltage. The transmitter has a 50 Ω load. All the results are summarized in Table 2.

It can be seen that the efficiency is almost constant when the proposed envelope amplifier is applied, and it goes from 36.4 to 43.8 percents. Comparing the EER transmitter when the proposed envelope amplifier and a linear regulator supplied by constant voltage are used, the advantage of the hybrid solution for the envelope amplifier is obvious, especially when the transmitted signal has low average value.

Having in mind the efficiencies that have been measured for envelope amplifier and the class E amplifier when they worked separately, the measured efficiency of the EER transmitter is lower than the expected one. There are two reasons for this. The first one is that the envelope amplifier has been designed and characterized for the 10 Ω load. Nevertheless, the input impedance of the class E amplifier is significantly lower, just 4 Ω . Therefore, the envelope amplifier has to manage much higher currents, and the switching losses in the multilevel converter and the first stage (flyback converter) are higher. The second reason is the input filter of the class E amplifier. When the measurements of the class E amplifier were done, it was supplied by constant voltage, and at its input, there was a low-pass filter that is used in order to

filter all the high harmonic from the input current. In order to supply the class E amplifier with variable voltage, this filter was changed, and this change lead to the deterioration of the efficiency.

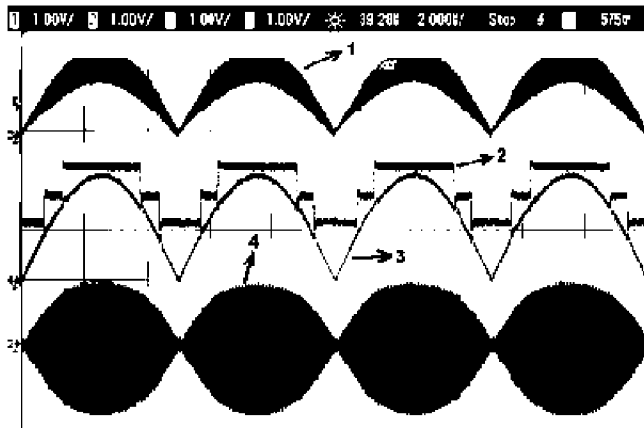

Figure 16. Oscilloscope waveforms of envelope reference (label 1), multilevel's output voltage (label 2), envelope amplifier's output (label 3) and the output of the implemented EER transmitter (label 4) when the transmitter's reference is a simple DSB-SC signal with carrier of 125 MHz and a 100 kHz sine wave as the modulated signal

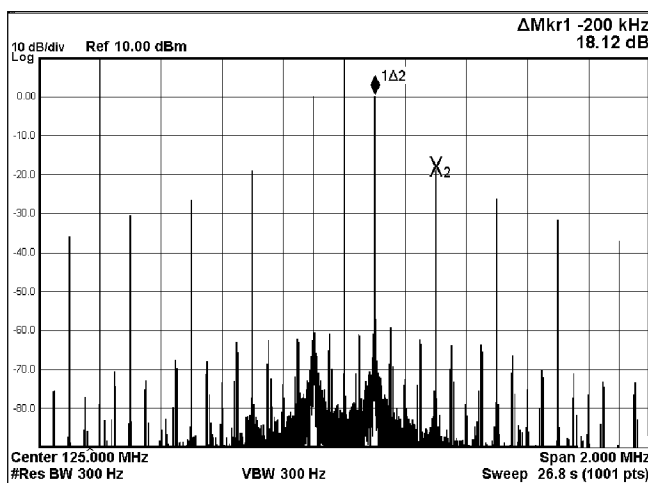

Figure 17. Spectrum of the transmitter's output signal when the system's reference is a simple DSB-SC signal with carrier of 125 MHz and a 100 kHz sine wave as the modulated signal

TABLE II. MEASURED EFFICIENCY OF THE IMPLEMENTED EER TRANSMITTER WHEN THE AMPLITUDE MODULATION IS APPLIED AND THE LINEAR REGULATOR IS SUPPLIED BY CONSTANT AND VARIABLE VOLTAGE

| Vsin(V) | Sine wave frequency (MHz) | Linear regulator's supply voltage | Output Power (dBm) | Measured efficiency |
|---------|---------------------------|-----------------------------------|--------------------|---------------------|
| 0-9 | 0.5 | Variable | 36.4 | 38.5% |
| 5-14 | 0.5 | Variable | 24.3 | 41.5% |
| 0-22.5 | 0.5 | Variable | 43.7 | 39.1% |
| 0-9 | 2 | Variable | 36.4 | 38.9% |
| 5-14 | 2 | Variable | 41.5 | 37.9% |
| 0-22.5 | 2 | Variable | 43.8 | 35.1% |
| 0-9 | 2 | Constant | 35.0 | 16.1% |
| 5-14 | 2 | Constant | 40.3 | 26.9% |
| 0-22.5 | 2 | Constant | 42.5 | 37.8% |

VI. CONCLUSIONS

In this paper a radio transmitter based on the Kahn's technique is presented. The implemented transmitter is composed of envelope amplifier (responsible for envelope injection) and class-E amplifier (performs phase modulation). The envelope amplifier has to fulfill strict requirements regarding its bandwidth and linearity, and, therefore, it is implemented as a multilevel converter in series with a linear regulator. In this way, high frequency signals can be reproduced applying relatively low switching frequency. The levels of the multilevel converter have been optimized in order to increase the efficiency of the system when the signals with high PAPR are transmitted. It has been shown that the proposed solution for the envelope amplifier can reproduce a sine wave of 2 MHz, and provide up to 100 W of peak power. When the transmitted signal has low average value, the efficiency of the proposed envelope amplifier is almost 50% higher than the efficiency of an ideal linear regulator supplied by constant voltage. The linearity of the envelope amplifier has been measured as well and the attenuation of the intermodulation products is about 50 dB.

The class-E amplifier operates at VHF band and its efficiency is about 90%. In order to reduce the driving power, the driver for the class-E amplifier is implemented as another class-E amplifier.

Different test have been performed with the implemented EER transmitter in order to characterize it. It has been shown that the envelope can be modulated with a 2 MHz sine wave. The attenuation of the intermodulation products when only AM is applied is about 30 dB. The efficiency of the implemented transmitter has been measured for different sine wave envelopes and it goes from 35% to 41%. If the envelope amplifier were implemented as a linear regulator supplied by constant voltage, the efficiency of the EER transmitter would be 50% to 100% lower than in the case when the envelope amplifier is made as a hybrid solution. Due to parasitic AM-PM modulation, the linearity of the transmitter when AM and PM are performed is only 18 dB and the work towards enhancement of the transmitter's linearity has been in progress. By implementing this transmitter we have proved that the Kahn's technique is possible to be implemented in this frequency and power range. This approach opens the possibility to enhance the efficiency of RF amplifiers.

VII. REFERENCES

- [1] F.H. Raab, "Intermodulation Distortion in Kahn-Technique Transmitters", IEEE Transactions on Microwave Theory and Techniques, Volume 44, Issue 12, Part 1, December 1996, Pages: 2273-2278
- [2] F.H.Raab, P.Asbeck, S.Cripps, P.B.Kenington, Z.B.Popovic, N.Pothecary, J.F.Sevic, N.O.Sokal, "RF and Microwave Power Amplifier and Transmitter Technologies - Part 1", High Frequency Electronics, Vol. 2, No.3, Pages:22-36, May 2003
- [3] Kahn, L.R. "Single-Sideband Transmission by Envelope Elimination and Restoration", Proceedings of the IRE, Vol. 40, No. 7, July 1952, pp. 803 - 806
- [4] F.H.Raab; P. Asbeck, S. Cripps, P.B. Kenington, Z.B. Popovic, N. Pothecary, J.F. Sevic, N.O. Sokal, "Power amplifiers and transmitters for RF and microwave", IEEE Transactions on Microwave Theory and Techniques, Volume 50, Issue 3, March 2002 Page(s):814 - 826

- [5] F. H. Raab and D. J. Rupp, "High efficiency single-sideband HF/ VHF transmitter based upon envelope elimination and restoration," Proc. Sixth Int. Conf. HF Radio Systems and Techniques (HF '94) (IEE CP 392), York, UK, pp. 21-25, July 4 - 7, 1994.
- [6] F. H. Raab, B. E. Sigmon, R. G. Myers, and R. M. Jackson, "L-band transmitter using Kahn EER technique," IEEE Trans. Microwave Theory Tech., pt. 2, vol. 46, no. 12, pp. 2220-2225, Dec. 1998.
- [7] F.J.O. González, A.G. Martín, J.M.P. Martín, C.B. Peces, "Amplificador de Potencia de Alto Rendimiento para Transmisores EER" Seminario Anual de Automática Electrónica Industrial SAAEI 2008, Cartagena, September 2008
- [8] J. Staudinger, B. Gilsdorf, D. Newman, G. Norris, G. Sadowiczak, R. Sherman, T. Quach, "High efficiency CDMA RF power amplifier using dynamic envelope tracking technique," Microwave Symposium Digest., IEEE MTT-S International, Vol. 2, June 2000, Pages: 873-876
- [9] A. Soto, J.A. Oliver, J.A. Cobos, J. Cezon, F. Arevalo, "Power supply for a radio transmitter with modulated supply voltage", Applied Power Electronics Conference, APEC '04, Volume: 1, Feb. 2004 Pages:392 – 398
- [10] V. Yousefzadeh, E. Alarcon, D. Maksimović, "Three-level buck converter for envelope tracking in RF power amplifiers," IEEE Trans. on Power Electronics, Volume:21, Issue: 2, March 2006, Pages:549 – 552
- [11] M.Vasić, O.Garcia, J.A.Oliver, P.Alou, D.Diaz, J.A.Cobos, "Multilevel Power Supply for High Efficiency RF Amplifier", Proc. of the 24th Annual IEEE Applied Power Electronics Conference, APEC '09, February 2009
- [12] N. O. Sokal, R. Redl, "Power Transistor Output Port Model", RF Design, Vol. 10, No. 6, pp. 45-48, 50, 51, 53, June 1987.
- [13] Ortega-Gonzalez,F.J, "Load-Pull Wideband Class-E Amplifier", Microwave and Wireless Components Letters, Vol. 17, No. 3, pp. 235-237, March 2007