

High speed frequency swept light source for Fourier domain OCT at 20 kHz A-scan rate

R. Huber, K. Taira, M. Wojtkowski, T. H. Ko, and J. G. Fujimoto

*Department of Electrical Engineering and Computer Science and Research Laboratory of Electronics
Massachusetts Institute of Technology, Cambridge, MA 02139
phone 617 253 8520, fax 617 253 9611, rhuber@mit.edu*

K. Hsu

*Micron Optics Inc.
1852 Century Place NE
Atlanta, GA 30345 USA*

Abstract: We demonstrate a high-speed tunable, continuous wave laser source for Fourier domain OCT. The laser source is based on a fiber coupled, semiconductor optical amplifier and a tunable ultrahigh finesse, fiber Fabry Perot filter for frequency tuning. The light source provides frequency scan rates of up to 20,000 sweeps per second over a wavelength range of >70 nm FWHM at 1330 nm, yielding an axial resolution of ~ 14 μ m in air. The linewidth is narrow and corresponds to a coherence length of several mm, enabling OCT imaging over a large axial range.

1. Introduction

Optical coherence tomography (OCT) enables cross sectional imaging of tissues in situ with micron scale resolution [1, 2]. Recently, new techniques for OCT, known as Fourier domain optical coherence tomography (FD-OCT) have been the topic of many investigations [3, 4]. Fourier domain OCT has been demonstrated to provide higher acquisition speed and better signal to noise ratio than OCT with time domain detection [5-7]. In time domain OCT an interferometer with a variable delay reference arm provides depth scanning of the backreflected or backscattered signal from the sample. However, in Fourier domain OCT the depth information in the signal is extracted by measuring the interference spectrum of the signal from the sample. There are two techniques for Fourier domain OCT imaging. In spectral domain OCT (SD-OCT), a broad spectrum light source is used and the output of the interferometer is measured with a spectrometer and a high speed CCD array or linescan camera. Another way to perform Fourier domain OCT is to sweep the frequency of a narrow band, continuous wave (cw) light source and collect the time dependent interference signal [6, 8-12]. This method is has been called optical frequency domain imaging (OFDI), swept source OCT, or chirped radar. Compared to spectral domain OCT, the detection system for OFDI or swept source OCT is simpler and lower cost because a high performance spectrometer and CCD camera are not required. Furthermore, dual balanced detection is possible in OFDI / swept source OCT and could enable superior performance compared to SD-OCT. However, a crucial technology for OFDI is a reliable cw light source with sufficiently narrow linewidth (long coherence length) that can be frequency tuned on a sub-millisecond time scale. Up to now, only a few frequency swept sources have been demonstrated to provide sweep rates of more than 10 kHz. Yun et al. demonstrated a system based on a semiconductor optical amplifier (SOA) and a diffraction grating in an external cavity for wavelength tuning [10]. In this paper, we demonstrate a fiber optic frequency swept source without any free space beam paths which achieves fast and reliable wavelength tuning without the need for any free space optical alignment.

2. Experimental setup

Fig. 1 (left) shows a schematic of the frequency swept laser. The ring cavity consists of a fiber coupled semiconductor amplifier (SOA), 2 isolators, a piezoelectric transducer actuated fiber Fabry-Perot tunable filter (FFP-TF), and an output coupler. The FFP-TF acts as a narrow-band transmission filter for active wavelength selection. The isolators eliminate all extraneous intra-cavity reflections and ensure unidirectional lasing of the ring cavity. The FFP-TF has a free spectral range of 270 nm, a bandwidth of ~ 0.135 nm, and a loss of ~ 2 dB, covering the complete spectral tuning range of the source. The high finesse of the FFP-TF provides narrow band spectral filtering suitable for achieving a sufficient dynamic coherence length of the source.

Fig. 1 (right) shows the experimental setup used for OCT imaging. A small fraction of the output power of the frequency swept source is split off and coupled into a separate reference FFP filter with a fixed frequency spacing of 100 GHz. This generates a transient frequency comb signal when the source is tuned over the transmission maxima of the FFP. The signal is used as a reference to recalibrate the sampled data to the laser frequency using a 6th order polynomial curve fit procedure which acts as a robust interpolation algorithm that can account for possible temporal jitter in the frequency. Synchronous clocking of the data signal should also be possible using this reference signal.

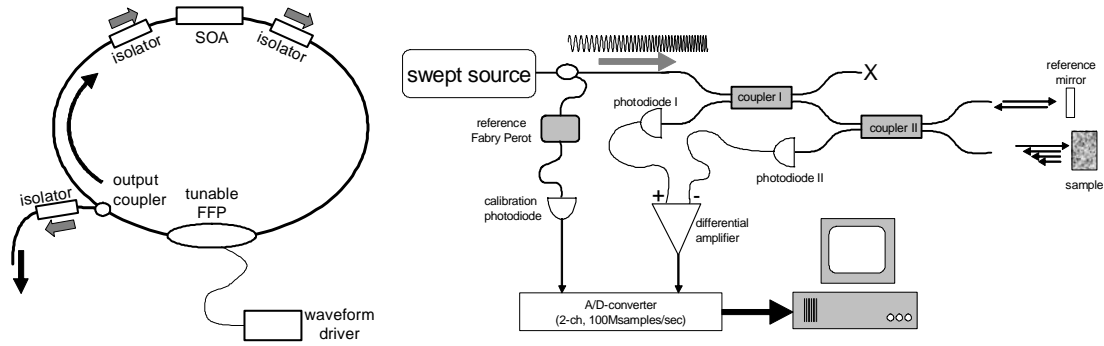

Fig. 1 (left): Schematic of the frequency swept laser source ring cavity. The laser uses a semiconductor optical amplifier (SOA) and fiber Fabry Perot (FFP) for high speed frequency tuning. (right): Experimental system for OFDI / swept source OCT. The system uses dual balanced detection to cancel excess noise.

The optical layout of the setup is analogous to a dual balanced, time domain OCT setup. The interference signals for dual balanced detection are generated using two, 50/50 fiber couplers. The differential signal is amplified and digitized at a sampling rate of 100 Msamples/sec. A 2-channel, 14-bit analog-to-digital acquisition card simultaneously records the calibration trace of the reference Fabry Perot and the sample signal. Depending on the sweep rate of the light source, a built-in 50 MHz antialiasing filter or a 20 MHz lowpass filter is applied.

3. Results

The average output power of the source decreases from 1.3 mW to 170 μ W as the frequency sweep rate is increased from 200 Hz to 20 kHz. Improved output powers should be possible using an additional stage of amplification. The total sweep range of the source covers more than 100 nm with a full width half maximum (FWHM) of \sim 70 nm at a 20 kHz sweep rate. Fig. 2 (left) shows the output spectrum of the source as the source is scanned from shorter to longer wavelengths. The output power and spectral bandwidth are depended upon the direction of the frequency scan with higher powers and bandwidths obtained scanning from higher to lower energy. Fig. 2 (right) shows the relative signal strengths in the OCT system for a single layer reflection at different path delay between the sample and reference arms. The point spread functions are obtained by Fourier transforming the interference fringe signals. The solid lines show the point spread functions and the crosses show the values calculated from the maximum observed fringe amplitude which directly reflects the coherence properties of the source. The peaks of the point spread functions exhibit a signal loss caused by temporal jitter within the single frequency sweeps and therefore are slightly lower in amplitude. It should be possible to improve this with better triggering. The figure indicates that, depending on imaging sensitivity requirements, a depth range of several millimeters can be obtained using this frequency swept laser source.

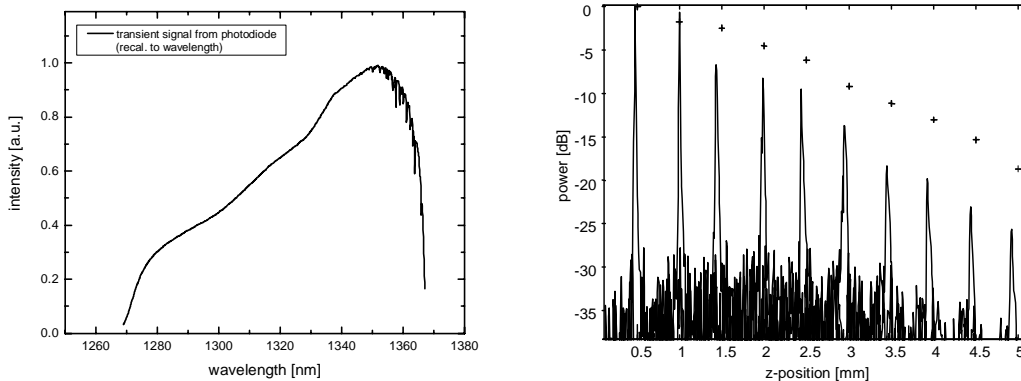

Fig 2 (left): spectrum of swept source; (right): Relative signal strengths for reflections at different axial positions.

Figure 3 (left) shows the axial resolution as determined by the amplitude signal from a single mirror reflection. The FWHM of the peak is 14 μ m in air, which is in reasonable agreement with the theoretical value of 11 μ m for a

Gaussian spectrum of 70 nm bandwidth. The residual broadening is probably the result of signal jitter and frequency nonlinearity. The sensitivity calculated from the peak value and the standard deviation of the noise floor is about 87 dB with an incident power at the sample of 41 μW . This value is only 6 dB lower than the theoretical value calculated at shot noise limit. Roundtrip losses in the sample arm power can account for the losses in signal to noise ratio; the measured values of sample arm power loss correlate well with the 6 dB losses in detection sensitivity. The OCT imaging capabilities of the swept light source setup are depicted in Figure 3 (right). Even with the low incident power, the OCT image of a human finger shows that morphological features like the stratum corneum, sweat ducts and the epidermis can be identified. Much higher power and detection sensitivity can be obtained using an optical amplifier stage which can provide a gain of about 20 dB in incident optical power.

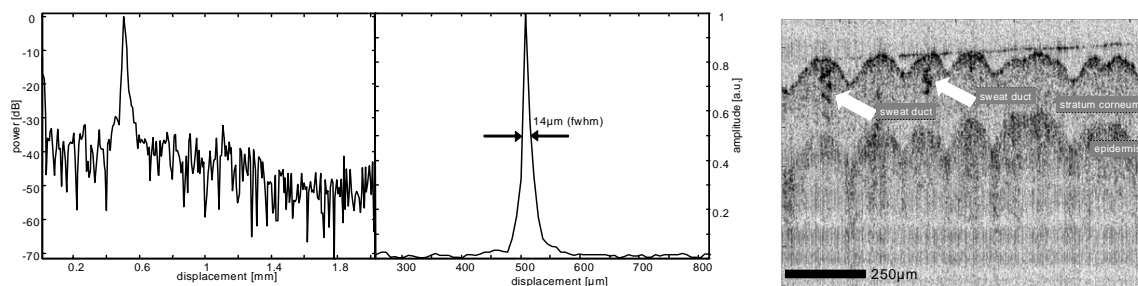

Fig 3 (left): Point spread function for swept source system showing 14 μm resolution in air. (right): OCT image of human finger taken at a sweep rate of 20 kHz. A sensitivity of 87 dB was obtained using 41 μW incident power.

4. Conclusion

This study demonstrates high speed OFDI / frequency swept source OCT at scan rates up to 20 kHz. These high speeds will enable novel imaging applications including 3-dimensional scanning and volumetric imaging. Since the frequency swept laser source is fiber optic and does not contain any bulk optics, it is robust, stable and maintenance free. To achieve the full performance advantage of Fourier domain OCT methods, a booster amplification stage will be required to obtain output power levels in the multi-mW range and sensitivities greater than 100 dB. These results demonstrate the potential for this new swept frequency source to enable reliable high speed and high sensitivity FD-OCT imaging at 1.3 μm wavelengths in biological tissues. We thank N. Nishizawa and V. Srinivasan for assistance and helpful discussions. This research was sponsored in part by National Institutes of Health R01-CA75289-06 and R01-EY11289-18, National Science Foundation ECS-01-19452 and BES-0119494, by the Air Force Office of Scientific Research Medical Free Electron Laser Program F49620-01-1-0186 and F49620-01-01-0084.

References

- Huang, D., et al., *Optical coherence tomography*. Science, 1991. **254**(5035): p. 1178-81.
- Fujimoto, J.G., *Optical coherence tomography for ultrahigh resolution in vivo imaging*. Nature biotechnology, 2003. **21**(11): p. 1361-7.
- Fercher, A.F., et al., *Measurement of Intraocular Distances by Backscattering Spectral Interferometry*. Optics Communications, 1995. **117**(1-2): p. 43-48.
- Hausler, G. and M.W. Lindner, "Coherence radar" and "spectral radar"-new tools for dermatological diagnosis. Journal of Biomedical Optics, 1998. **3**(1): p. 21-31.
- de Boer, J.F., et al., *Improved signal-to-noise ratio in spectral-domain compared with time-domain optical coherence tomography*. Opt Lett, 2003. **28**(21): p. 2067-9.
- Choma, M.A., et al., *Sensitivity advantage of swept source and Fourier domain optical coherence tomography*. Optics Express, 2003. **11**(18): p. 2183-2189.
- Leitgeb, R., C.K. Hitzenberger, and A.F. Fercher, *Performance of Fourier domain vs. time domain optical coherence tomography*. Optics Express, 2003. **11**(8).
- Chinn, S.R., E.A. Swanson, and J.G. Fujimoto, *Optical coherence tomography using a frequency-tunable optical source*. Optics Letters, 1997. **22**(5): p. 340-2.
- Golubovic, B., et al., *Optical frequency-domain reflectometry using rapid wavelength tuning of a Cr/sup 4+/:forsterite laser*. Optics Letters, 1997. **22**(22): p. 1704-6.
- Yun, S.H., et al., *High-speed spectral-domain optical coherence tomography at 1.3 μm wavelength*. Optics Express, 2003. **11**(26): p. 3598-3604.
- Yun, S.H., et al., *High-speed wavelength-swept semiconductor laser with a polygon-scanner-based wavelength filter*. Optics Letters, 2003. **28**(20): p. 1981-1983.
- Yun, S.H., et al., *Motion artifacts in optical coherence tomography with frequency-domain ranging*. Optics Express, 2004. **12**(13): p. 2977-2998.