

HILBERT FORMULAS FOR r -ANALYTIC FUNCTIONS AND THE STOKES FLOW ABOUT A BICONVEX LENS

BY

MICHAEL ZABARANKIN (*Department of Mathematical Sciences, Stevens Institute of Technology,
Castle Point on Hudson, Hoboken, New Jersey 07030*)

AND

ANDREI F. ULITKO (*Department of Mechanics and Mathematics, National Taras Shevchenko
University of Kiev, 7 Academic Glushkov Prospect, Kiev, Ukraine*)

Abstract. The so-called r -analytic functions are a subclass of p -analytic functions and are defined by the generalized Cauchy-Riemann system with $p(r, z) = r$. In the system of toroidal coordinates, the real and imaginary parts of an r -analytic function are represented by Mehler-Fock integrals with densities, which are assumed to be meromorphic functions. Hilbert formulas, establishing relationships between those functions, are derived for the domain exterior to the contour of a biconvex lens in the meridional cross-section plane. The derivation extends the framework of the theory of Riemann boundary-value problems, suggested in our previous work, to solving the three-contour problem for the case of meromorphic functions with a finite number of simple poles. For numerical calculations, Mehler-Fock integrals with Hilbert formulas reduce to the form of regular integrals. The 3D problem of the axially symmetric steady motion of a rigid biconvex lens-shaped body in a Stokes fluid is solved, and the Hilbert formula for the real part of an r -analytic function is used to express the pressure in the fluid via the vorticity analytically. As an illustration, streamlines and isobars about the body, the vorticity and pressure at the contour of the body and the drag force exerted on the body by the fluid are calculated.

Introduction. The theory of analytic functions of a complex variable has been and continues to be one of the most efficient analytical frameworks for solving two-dimensional (2D) problems in a variety of applications of mathematical physics, in particular, the theory of elasticity and hydrodynamics [10, 24]. For example, a displacement vector in planar problems for an elastic media is expressed by Kolosov-Muskhelishvili formulas

Received October 24, 2005.

2000 *Mathematics Subject Classification.* Primary 30E20, 35Q15, 35Q30, 76D07.

Key words and phrases. r -analytic function, generalized Cauchy-Riemann system, Hilbert formula, Riemann boundary-value problem, analytic function, biconvex lens, toroidal coordinates, Mehler-Fock integral transform, Stokes model, pressure, vorticity, drag force.

E-mail address: `mzabaran@stevens.edu`

©2006 Brown University
Reverts to public domain 28 years from publication

[24], which are linear combinations of two analytic functions and their derivatives. In the hydrodynamics of 2D Stokes flows, the Cauchy-Riemann system arises from the relationship between the vorticity and pressure in a fluid. This fact allows one to express the pressure via the vorticity analytically. Consider the last case in detail. The Stokes model [10, 14, 22] determines the behavior of a viscous incompressible fluid under low Reynolds numbers

$$\begin{cases} \operatorname{curl}(\operatorname{curl} \mathbf{u}) = -\operatorname{grad} \theta, \\ \operatorname{div} \mathbf{u} = 0, \end{cases} \quad (0.1)$$

where \mathbf{u} is the velocity vector of the fluid particles, and θ corresponds to the pressure \mathcal{P} in the fluid ($\theta = \mathcal{P}/\rho$, where ρ is the shear viscosity). Defining the vorticity by

$$\boldsymbol{\omega} = \operatorname{curl} \mathbf{u}, \quad (0.2)$$

we obtain from the first equation in (0.1) that the vector $\boldsymbol{\omega}$ and the function θ are related by

$$\operatorname{grad} \theta = -\operatorname{curl} \boldsymbol{\omega}. \quad (0.3)$$

Suppose that 2D Stokes flows are considered in the (x, y) -plane in cartesian coordinates (x, y, z) . Then $\boldsymbol{\omega}$ has only one nonzero component, namely $\boldsymbol{\omega} = (0, 0, \omega_z)$. In this case, equation (0.3) reduces to the Cauchy-Riemann system for an analytic function $F = \theta + i\omega_z$, where $i = \sqrt{-1}$. Consequently, if we know the value of the imaginary part, ω_z , at the boundary of some 2D domain, then we can obtain the value of the real part, θ , at the same boundary by Hilbert formulas [6], and vice versa.

The theory of analytic functions is not used to the same extent for solving three-dimensional problems (3D) in the aforementioned applications. For example, for an arbitrary 3D Stokes flow, the vorticity $\boldsymbol{\omega}$ has three components, and relation (0.3) is equivalent to three scalar equations. However, in the case of axially symmetric 3D Stokes flows, the vector $\boldsymbol{\omega}$ can be represented by one scalar vortex function, ω . Indeed, let (r, φ, z) be a system of cylindrical coordinates with basis $(\mathbf{e}_r, \mathbf{e}_\varphi, \mathbf{k})$, and let the z -axis be the axis of symmetry. In the axially symmetric case, the vector \mathbf{u} is independent of the angular coordinate φ , and thus, $\boldsymbol{\omega} = \omega \mathbf{e}_\varphi$. Consequently, since θ and ω depend only on r and z , the vectorial equation (0.3) reduces to the generalized Cauchy-Riemann system

$$\frac{\partial \theta}{\partial r} = \frac{1}{r} \frac{\partial}{\partial z} (r\omega), \quad \frac{\partial \theta}{\partial z} = -\frac{1}{r} \frac{\partial}{\partial r} (r\omega), \quad (0.4)$$

which defines a so-called r -analytic function $F(r, z) = \theta(r, z) + i r \omega(r, z)$, where the functions θ and $r\omega$ are considered to be real and imaginary parts of the r -analytic function, respectively. System (0.4) implies that $\theta(r, z)$ and $\omega(r, z)$ are harmonic and 1-harmonic functions, respectively, i.e.,

$$\Delta \theta = 0, \quad \Delta_1 \omega = 0, \quad (0.5)$$

where Δ_k denotes a so-called k -harmonic operator

$$\Delta_k = \frac{\partial^2}{\partial r^2} + \frac{1}{r} \frac{\partial}{\partial r} + \frac{\partial^2}{\partial z^2} - \frac{k^2}{r^2}, \quad (0.6)$$

with $\Delta \equiv \Delta_0$. Establishing existence and uniqueness of solutions to (0.5) under the condition that the values of the functions θ and ω are given at the smooth boundary $\partial \mathcal{D}$

of a domain \mathcal{D} in the meridional cross-section (r, z) -plane is a Dirichlet problem, which is discussed in 3D potential theory [26]. For the domain exterior to \mathcal{D} , a harmonic function vanishing at infinity in 3D space is uniquely determined by its boundary value at $\partial\mathcal{D}$.

System (0.4) provides only one of the possible generalizations of the classical Cauchy-Riemann equations, and consequently, defines only a particular class of generalized analytic functions. The theory of generalized analytic or pseudoanalytic functions has been mostly developed by Bers [3], Polozhii [19] and Vekua [25]. For example, r -analytic functions are a special case of p -analytic functions [19] when $p(r, z) = r$. They are encountered in different areas of mathematical physics, in particular, the theory of elasticity [8, 19, 24] and hydrodynamics [24, 32, 34]. For domains determined by the surface of bodies of revolution in the meridional cross-section plane, Polozhii [19] obtained integral representations for p -analytic functions via analytic functions and generalized Kolosov-Muskhelishvili formulas for axially symmetric problems of the linear theory of elasticity.

Of special interest is the problem of obtaining Hilbert formulas for r -analytic functions in different domains described by systems of separable coordinates. As in the case of analytic functions, Hilbert formulas relate the real and imaginary parts and are used in problems of axially symmetric Stokes flows to express the function θ via the vortex ω analytically. If in curvilinear coordinates, harmonic functions θ and ω are represented by integrals with densities that are analytic functions, then the Generalized Cauchy-Riemann system (0.4) reduces to a pair of equations for those analytic functions. Strictly speaking, by Hilbert formulas we will understand the relationships between those functions. Integral and series representations for r -analytic functions in domains exterior to the contour of bodies described by cycloidal coordinates (lens, spindle, torus and two-spheres) in the meridional cross-section plane are discussed in [24]. It is worth mentioning that Hilbert formulas can also be derived by integrating the generalized Cauchy-Riemann system (0.4) analytically. Indeed, from system (0.4), functions θ and $r\omega$ can be represented by integrals

$$\begin{aligned}\theta(r, z) &= \int_L \left(\frac{\partial\omega}{\partial z} dr - \frac{1}{r} \frac{\partial}{\partial r} (r\omega) dz \right) + \theta(r_0, z_0), \\ r\omega(r, z) &= \int_L r \left(\frac{\partial\theta}{\partial r} dz - \frac{\partial\theta}{\partial z} dr \right) + r_0\omega(r_0, z_0),\end{aligned}$$

along some smooth curve L from point (r_0, z_0) to point (r, z) . Using this approach, we obtained Hilbert formulas for an r -analytic function in bi-spherical coordinates [32]. However, this approach is cumbersome and substantially depends on peculiar properties of special functions associated with a corresponding system of curvilinear coordinates. For example, in the case of toroidal coordinates, we anticipate extensive analytical computations in derivation of the Hilbert formulas by integrating system (0.4) analytically.

In our previous work [31], we derived Hilbert formulas for the domain exterior to the contour of a spindle in the framework of the theory of Riemann boundary-value problems [6]. We represented functions θ and ω by Fourier integrals in bipolar coordinates and reduced system (0.4) to a so-called three-contour problem for the densities of those integrals in the infinite strip $-1 \leq \operatorname{Re} \mu \leq 1$. We assumed that the densities were functions meromorphic in the strip with only two simple poles at $\mu = \pm \frac{1}{2}$. Then, using conformal

mapping, we reformulated the three-contour problem as the Riemann boundary-value problem for finding an analytic function in the plane with the branch cut along the segment $[-1, 1]$. A solution to this problem was represented by a Cauchy integral, and boundary values of that solution at the upper and lower banks of the branch cut were expressed by the Sokhotski formulas [6].

In this paper, we derive Hilbert formulas for an r -analytic function for the domain exterior to the contour of a biconvex lens in the meridional cross-section plane and apply these formulas in the 3D problem of axially symmetric steady motion of a rigid biconvex lens-shaped body in a Stokes fluid. Using Mehler-Fock integral representations for θ and ω in toroidal coordinates (see [20, 24]), we reduce (0.4) to the same three-contour problem for the densities in the Mehler-Fock integrals that was obtained in [31] for the corresponding densities in the Fourier integrals. However, in contrast to [31], here we assume that the densities are from the class of meromorphic functions with an arbitrary number of simple poles in $-1 \leq \operatorname{Re} \mu \leq 1$. Extending the approach of the Riemann boundary-value problems [31] to solving the three-contour problem for this class of meromorphic functions, we show that the Hilbert formulas are exactly those that we obtained in [31]. Since Hilbert formulas are expressed by singular integrals, for numerical calculations, we reduce the Mehler-Fock integrals with the Hilbert formulas to the form of regular integrals.

In the second part of the paper, we solve the 3D problem of axially symmetric steady motion of a rigid biconvex lens-shaped body in a Stokes fluid. A classical approach to constructing analytical solutions for 3D problems of axially symmetric Stokes flows is based on the notion of a scalar stream function. This approach was originally suggested by Stokes [22] who made use of it in the study of steady motion of a rigid sphere in a viscous incompressible fluid under low Reynolds numbers. Since then the stream function approach was successfully applied for studying axially symmetric Stokes flows about rigid bodies described by cycloidal coordinates: spherical cap [5, 24], two-spheres [21, 30], torus [7, 9, 13, 18, 23, 24, 29], lens-shaped body [5, 24, 27], and spindle-shaped body [17, 31, 32, 34]. However, in the case of cycloidal coordinates, this approach does not allow one to express the pressure in terms of a stream function. To our knowledge, analytic formulas for the pressure in the mentioned studies were obtained only for a torus [24] and a spindle-shaped body [31, 32] by corresponding Hilbert formulas. In this paper, we solve the problem of the steady axially symmetric motion of a rigid biconvex lens-shaped body in a Stokes fluid using a stream function similar to that proposed in [31]. However, in contrast to the stream function in [31], the one in this paper includes an additional term to provide proper representations of boundary conditions in the form of Mehler-Fock integrals. This term corresponds to the solution for the problem of axially symmetric steady motion of a rigid sphere in the Stokes fluid and is different from those suggested in [16, 24]. Using the Hilbert formulas derived in the first part of the paper, we obtain an analytic expression for the pressure in the fluid, based on which we calculate *épure*s of the pressure at the contour of the body and isobars about the body. In addition, we calculate streamlines about the body, *épure*s of the vorticity at the contour of the body and the drag force exerted on the body by the fluid.

The paper follows closely the structure of our previous work [31] and is organized as follows. Section 1 represents an r -analytic function in the domain exterior to the contour of a biconvex lens in the meridional cross-section plane. Section 2 derives Hilbert formulas for r -analytic functions in the framework of the theory of Riemann boundary-value problems for analytic functions. Section 3 solves the problem of steady axially symmetric motion of a rigid biconvex lens-shaped body in a Stokes fluid. Section 4 obtains analytic expressions for the pressure and drag force exerted on the body. Section 5 concludes the paper. The appendix proves the proposition on representations for the Mehler-Fock integrals with the Hilbert formulas in the form of regular integrals.

1. An r -analytic function in the domain exterior to a biconvex lens. Let (r, φ, z) be a system of cylindrical coordinates with basis $(\mathbf{e}_r, \mathbf{e}_\varphi, \mathbf{k})$, and let the z -axis be the axis of symmetry. In the meridional cross-section (r, z) -plane, toroidal coordinates (ξ, η) are introduced by

$$r = c \frac{\sinh \xi}{\cosh \xi - \cos \eta}, \quad z = c \frac{\sin \eta}{\cosh \xi - \cos \eta}, \quad \begin{matrix} 0 \leq \xi < +\infty, \\ -\pi \leq \eta \leq \pi, \end{matrix} \quad (1.1)$$

where c is a metric parameter of toroidal coordinates. A biconvex lens is an axially symmetric body, whose contour in the (r, z) -plane consists of two symmetric circle arcs $\eta = \eta_0$ and $\eta = -\eta_0$ (see Figure 1). For example, the surface of the biconvex lens for $\eta_0 = \frac{\pi}{2}$ forms a sphere.

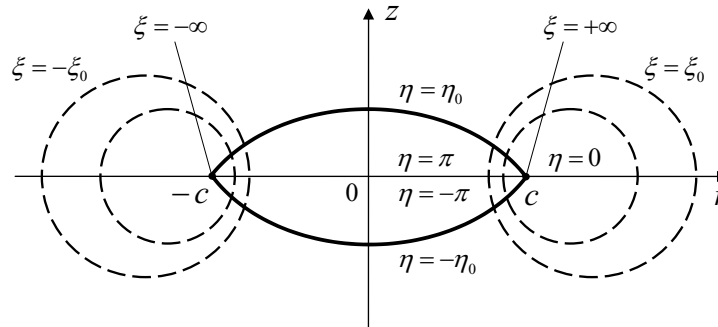

FIG. 1. Toroidal coordinates and biconvex lens-shaped body

In the system of toroidal coordinates, derivatives $\frac{\partial}{\partial r}$, $\frac{\partial}{\partial z}$ and the k -harmonic operator Δ_k , defined by (0.6), take the form

$$\begin{aligned} \frac{\partial}{\partial r} &= -\frac{1}{c} \left((\cosh \xi \cos \eta - 1) \frac{\partial}{\partial \xi} + \sinh \xi \sin \eta \frac{\partial}{\partial \eta} \right), \\ \frac{\partial}{\partial z} &= -\frac{1}{c} \left(\sinh \xi \sin \eta \frac{\partial}{\partial \xi} - (\cosh \xi \cos \eta - 1) \frac{\partial}{\partial \eta} \right), \\ \Delta_k &= \frac{(\cosh \xi - \cos \eta)^2}{c^2} \left(\frac{\partial^2}{\partial \xi^2} + \frac{\partial^2}{\partial \eta^2} + \left(\coth \xi - \frac{\sinh \xi}{\cosh \xi - \cos \eta} \right) \frac{\partial}{\partial \xi} \right. \\ &\quad \left. - \frac{\sin \eta}{\cosh \xi - \cos \eta} \frac{\partial}{\partial \eta} - \frac{k^2}{\sinh^2 \xi} \right). \end{aligned} \quad (1.2)$$

Let $F(r, z) = \theta(r, z) + i r \omega(r, z)$ be an r -analytic function satisfying system (0.4). In this case, θ and ω are harmonic and 1-harmonic functions defined by (0.5). In the domain exterior to the contour of the biconvex lens in the (r, z) -plane, an arbitrary k -harmonic function is represented by a Mehler-Fock integral with respect to the variable ξ . The reader interested in the Mehler-Fock integral transform and its applications may refer to [20, 24]. Thus, in toroidal coordinates, functions $\theta(\xi, \eta)$ and $\omega(\xi, \eta)$ take the form [12, 24]:

$$\theta(\xi, \eta) = -\frac{1}{2\pi} \sqrt{\cosh \xi - \cos \eta} \int_{-i\infty}^{+i\infty} X(\mu) P_{-\frac{1}{2}+\mu}(\cosh \xi) e^{i\eta\mu} d\mu, \quad -\eta_0 \leq \eta \leq \eta_0, \quad (1.3)$$

$$\omega(\xi, \eta) = \frac{1}{2\pi i} \sqrt{\cosh \xi - \cos \eta} \int_{-i\infty}^{+i\infty} Y(\mu) P_{-\frac{1}{2}+\mu}^{(1)}(\cosh \xi) e^{i\eta\mu} d\mu, \quad -\eta_0 \leq \eta \leq \eta_0, \quad (1.4)$$

where $P_{-\frac{1}{2}+\mu}^{(k)}(\cosh \xi)$ is the associated Legendre function of the first kind of complex index μ , see [1]. For $k = 0$, the upper index (k) is omitted. In the case of $\operatorname{Re} \mu = 0$, $P_{-\frac{1}{2}+\mu}^{(k)}(\cosh \xi)$ is called a toroidal function. At $\tau \rightarrow \infty$, the function $P_{-\frac{1}{2}+i\tau}^{(k)}(\cosh \xi)$, $\tau \in \mathbb{R}$, for $k = 0, 1$ behaves as

$$P_{-\frac{1}{2}+i\tau}(\cosh \xi) \sim \sqrt{\frac{2}{\pi\tau \sinh \xi}} \cos \left[\tau\xi - \frac{\pi}{4} \right],$$

$$P_{-\frac{1}{2}+i\tau}^{(1)}(\cosh \xi) \sim -\sqrt{\frac{2\tau}{\pi \sinh \xi}} \sin \left[\tau\xi - \frac{\pi}{4} \right].$$

Consequently, we require functions $X(i\tau)$ and $Y(i\tau)$ in the Mehler-Fock integrals (1.3) and (1.4) to have exponentially fast convergence $Ce^{-\gamma|\tau|}$ at $\tau \rightarrow \pm\infty$, where C is a constant, and $\gamma > \eta_0$.

Note that the harmonic functions θ and ω represented by (1.3) and (1.4), respectively, vanish at infinity, $\sqrt{r^2 + z^2} \rightarrow \infty$, that is, at $\xi \rightarrow 0$ and $\eta \rightarrow 0$. This guarantees uniqueness of solutions to a Dirichlet problem for (0.5) in the domain of consideration.

PROPOSITION 1.1. Let functions θ and ω be represented by the Mehler-Fock integrals (1.3) and (1.4), respectively. Then the equation $\frac{\partial\theta}{\partial r} = \frac{\partial\omega}{\partial z}$, relating the functions θ and ω in (0.4), is equivalent to the equation $\frac{\partial\theta}{\partial z} = -\frac{1}{r} \frac{\partial}{\partial r}(r\omega)$.

Proof. We will show that under the conditions of the proposition, the equation $\frac{\partial\theta}{\partial r} = \frac{\partial\omega}{\partial z}$ implies $\frac{\partial\theta}{\partial z} = -\frac{1}{r} \frac{\partial}{\partial r}(r\omega)$. The converse can be proved similarly. Recall that θ and ω satisfy: $\Delta\theta = 0$ and $\Delta_1\omega = 0$, respectively. Consequently, substituting $\frac{\partial\theta}{\partial r} = \frac{\partial\omega}{\partial z}$ into the equation $\Delta\theta = 0$, we have:

$$\frac{1}{r} \frac{\partial}{\partial r} \left(r \frac{\partial\omega}{\partial z} \right) + \frac{\partial^2\theta}{\partial z^2} = 0 \quad \implies \quad \frac{1}{r} \frac{\partial}{\partial r} (r\omega) + \frac{\partial\theta}{\partial z} = f(r),$$

where $f(r)$ is an arbitrary function, which depends only on r . Similarly, substituting $\frac{\partial\omega}{\partial z} = \frac{\partial\theta}{\partial r}$ into the equation $\Delta_1\omega = 0$, we obtain:

$$\frac{1}{r} \frac{\partial}{\partial r} (r\omega) + \frac{\partial\theta}{\partial z} = g(z),$$

where $g(z)$ is an arbitrary function depending only on z . The last two equations can hold together only if $f(r) = g(z) = \tilde{c}$, where \tilde{c} is a constant. Now we need to show that $\tilde{c} = 0$. Multiplying equations $\frac{\partial \theta}{\partial r} = \frac{\partial \omega}{\partial z}$ and $\frac{\partial \theta}{\partial z} = -\frac{1}{r} \frac{\partial}{\partial r} (r\omega) + \tilde{c}$ by dr and dz , respectively, and integrating the sum of the two products along a smooth open curve from point (r_1, z_1) to point (r_2, z_2) , we obtain

$$\theta(r_2, z_2) - \theta(r_1, z_1) = \int_{(r_1, z_1)}^{(r_2, z_2)} \left(\frac{\partial \omega}{\partial z} dr - \frac{1}{r} \frac{\partial}{\partial r} (r\omega) dz \right) + \tilde{c}(z_2 - z_1). \tag{1.5}$$

Note that the integral in this expression is uniquely determined, i.e., the integral value is independent of the curve L connecting the points (r_1, z_1) and (r_2, z_2) . Indeed, based on Green's Theorem, the integral $\int_{(r_1, z_1)}^{(r_2, z_2)} (Q dr + R dz)$ is uniquely determined if $\frac{\partial Q}{\partial z} - \frac{\partial R}{\partial r} = 0$. In this case, $R = \frac{\partial \omega}{\partial z}$, $Q = -\frac{1}{r} \frac{\partial}{\partial r} (r\omega)$, and, thus, $\frac{\partial}{\partial z} (\frac{\partial \omega}{\partial z}) + \frac{\partial}{\partial r} (\frac{1}{r} \frac{\partial}{\partial r} (r\omega)) \equiv \Delta_1 \omega \equiv 0$.

Now suppose that the left-hand and right-hand sides in (1.5) are evaluated at $r_1 = 0$, some fixed $z_1 \geq c \frac{\sin \eta_0}{1 - \cos \eta_0}$, $r_2 = 0$, and $z_2 \rightarrow \infty$, and the integral in (1.5) is calculated along the line L connecting the points (r_1, z_1) and (r_2, z_2) . In toroidal coordinates, these points correspond to $\xi_1 = 0$, some fixed $\eta_1 \leq \eta_0$, $\xi_2 = 0$, and $\eta_2 \rightarrow 0$, respectively, and the line L is determined by $\xi = 0$ and $\eta_1 \leq \eta \leq \eta_2$. Obviously, the Mehler-Fock integral (1.3) converges for $\xi_1 = 0$, η_1 , and $\xi_2 = 0$, $\eta_2 \rightarrow 0$, and consequently in this case, the left-hand side in (1.5) is bounded. If we show that the integral in (1.5) converges, then this will mean that \tilde{c} should equal zero since $(z_2 - z_1) \rightarrow \infty$. Using the relation

$$\begin{aligned} \frac{\partial \omega}{\partial z} dr - \frac{1}{r} \frac{\partial}{\partial r} (r\omega) dz &= \left(\frac{\sin \eta}{\cosh \xi - \cos \eta} \omega - \frac{\partial \omega}{\partial \eta} \right) d\xi \\ &+ \left(\frac{\partial \omega}{\partial \xi} - \frac{(\cosh \xi \cos \eta - 1)}{\sinh \xi (\cosh \xi - \cos \eta)} \omega \right) d\eta, \end{aligned}$$

coupled with representation (1.4), and taking into account that at the line L , $d\xi = 0$, we obtain

$$\begin{aligned} \int_L \left(\frac{\partial \omega}{\partial z} dr - \frac{1}{r} \frac{\partial}{\partial r} (r\omega) dz \right) &= \lim_{\eta_2 \rightarrow 0} \int_{\eta_1}^{\eta_2} \left[\lim_{\xi \rightarrow 0} \left(\frac{\partial \omega}{\partial \xi} - \frac{(\cosh \xi \cos \eta - 1)}{\sinh \xi (\cosh \xi - \cos \eta)} \omega \right) \right] d\eta \\ &= \lim_{\eta_2 \rightarrow 0} \int_{\eta_1}^{\eta_2} \left[\frac{1}{2\pi i} \sqrt{1 - \cos \eta} \int_{-i\infty}^{+i\infty} (\mu^2 - \frac{1}{4}) Y(\mu) e^{i\eta\mu} d\mu \right] d\eta \\ &= \frac{1}{2\sqrt{2}\pi i} \lim_{\eta_2 \rightarrow 0} \int_{-i\infty}^{+i\infty} Y(\mu) \left[(\cos \frac{\eta}{2} - 2i\mu \sin \frac{\eta}{2}) e^{i\eta\mu} \right]_{\eta_1}^{\eta_2} d\mu, \end{aligned}$$

where the change of the order of integration is valid, because the integral in the second line, $\int_{-i\infty}^{+i\infty} (\mu^2 - \frac{1}{4}) Y(\mu) e^{i\eta\mu} d\mu$, is convergent for all $\eta \in [\eta_2, \eta_1] \subseteq [0, \eta_0]$ based on the assumption that $Y(i\tau) \sim Ce^{-\gamma|\tau|}$, at $\tau \rightarrow \pm\infty$, where $\gamma > \eta_0$. Obviously, the last obtained integral in the third line is convergent for $\eta_2 = 0$. Consequently, in this case, expression (1.5) can hold only if $\tilde{c} = 0$.

Now consider the converse, i.e., that the equation $\frac{\partial \theta}{\partial z} = -\frac{1}{r} \frac{\partial}{\partial r} (r\omega)$ implies $\frac{\partial \theta}{\partial r} = \frac{\partial \omega}{\partial z}$. By similar reasoning, we obtain that $\frac{\partial \theta}{\partial r} = \frac{\partial \omega}{\partial z} + \frac{\hat{c}}{r}$, where \hat{c} is a constant. Showing that the derivatives $\frac{\partial \theta}{\partial r}$ and $\frac{\partial \omega}{\partial z}$ are finite at $r \rightarrow 0$, we conclude that $\hat{c} = 0$, and the statement is proved. \square

Proposition 1.1 means that for deriving a relationship between $X(\mu)$ and $Y(\mu)$ it is enough to consider merely one of the equations in (0.4), for example, $\frac{\partial \theta}{\partial r} = \frac{\partial \omega}{\partial z}$.

2. Problem for an analytic function on three parallel contours. Let $\mathcal{A}_{[a,b]}$ and $\mathcal{M}_{[a,b]}$ be the spaces of functions that are analytic (holomorphic) and meromorphic in the strip $a \leq \text{Re } \mu \leq b$, respectively, and have exponentially fast convergence at $|\mu| \rightarrow \infty$, i.e., vanish as $Ce^{-\gamma|\tau|}$, where C is a constant, and $\gamma > \eta_0$. We define the following spaces of functions:

- Space $\mathcal{M}_{[0,1]}$: functions have simple poles at $\mu_0^+ = \frac{1}{2}$ and μ_k^+ with $\text{Re } \mu_k^+ \in (\frac{1}{2}, 1]$, $1 \leq k \leq n_1$.
- Space $\mathcal{M}_{[-1,0]}$: functions have simple poles at $\mu_0^- = -\frac{1}{2}$ and μ_k^- with $\text{Re } \mu_k^- \in [-1, -\frac{1}{2})$, $1 \leq k \leq n_2$.
- Space $\mathcal{M}_{[-1,1]}$: functions have simple poles at $\mu_0^+ = \frac{1}{2}$, $\mu_0^- = -\frac{1}{2}$, μ_k^+ with $\text{Re } \mu_k^+ \in (\frac{1}{2}, 1]$, $1 \leq k \leq n_1$, and μ_k^- with $\text{Re } \mu_k^- \in [-1, -\frac{1}{2})$, $1 \leq k \leq n_2$.
- Space $\mathcal{M}_{[a,b]}^0 \subset \mathcal{M}_{[a,b]}$: functions have simple poles at $\mu = \pm \frac{1}{2}$ only.

Suppose $X(\mu), Y(\mu) \in \mathcal{M}_{[-1,1]}$ and $\eta \in [-\eta_0, \eta_0]$. Under these assumptions, the following relations hold:

$$\begin{aligned} \frac{\partial \theta}{\partial r} = & \frac{1}{4\pi c} \sqrt{\cosh \xi - \cos \eta} \int_{-i\infty}^{+i\infty} (X(\mu + 1) - 2X(\mu) + X(\mu - 1)) P_{-\frac{1}{2}+\mu}^{(1)}(\cosh \xi) e^{i\eta\mu} d\mu \\ & + \frac{i}{2c} \sqrt{\cosh \xi - \cos \eta} \left(\begin{aligned} & \sum_{k=1}^{n_2} \text{Res}_{\mu=\mu_k^-} [X(\mu)] P_{\frac{1}{2}+\mu_k^-}^{(1)}(\cosh \xi) e^{i\eta(\mu_k^-+1)} \\ & - \sum_{k=1}^{n_1} \text{Res}_{\mu=\mu_k^+} [X(\mu)] P_{-\frac{3}{2}+\mu_k^+}^{(1)}(\cosh \xi) e^{i\eta(\mu_k^+-1)} \end{aligned} \right), \end{aligned} \tag{2.1}$$

$$\begin{aligned} \frac{\partial \omega}{\partial z} = & \frac{1}{4\pi c} \sqrt{\cosh \xi - \cos \eta} \int_{-i\infty}^{+i\infty} \left(\begin{aligned} & (\mu + \frac{3}{2}) Y(\mu + 1) - 2\mu Y(\mu) \\ & + (\mu - \frac{3}{2}) Y(\mu - 1) \end{aligned} \right) P_{-\frac{1}{2}+\mu}^{(1)}(\cosh \xi) e^{i\eta\mu} d\mu \\ & + \frac{i}{2c} \sqrt{\cosh \xi - \cos \eta} \left(\begin{aligned} & \sum_{k=1}^{n_2} \text{Res}_{\mu=\mu_k^-} [Y(\mu)] (\mu_k^- - \frac{1}{2}) P_{\frac{1}{2}+\mu_k^-}^{(1)}(\cosh \xi) e^{i\eta(\mu_k^-+1)} \\ & - \sum_{k=1}^{n_1} \text{Res}_{\mu=\mu_k^+} [Y(\mu)] (\mu_k^+ + \frac{1}{2}) P_{-\frac{3}{2}+\mu_k^+}^{(1)}(\cosh \xi) e^{i\eta(\mu_k^+-1)} \end{aligned} \right). \end{aligned} \tag{2.2}$$

The derivation of these formulas is similar to that discussed in the appendix in our paper [31]. Substituting (2.1) and (2.2) into the first equation of system (0.4), we obtain an equation for $X(\mu)$ and $Y(\mu)$:

$$X(\mu + 1) - 2X(\mu) + X(\mu - 1) = (\mu + \frac{3}{2}) Y(\mu + 1) - 2\mu Y(\mu) + (\mu - \frac{3}{2}) Y(\mu - 1), \tag{2.3}$$

where $\mu = i\tau$, $\tau \in \mathbb{R}$, and we have the additional conditions

$$\begin{aligned} \operatorname{Res}_{\mu=\mu_k^+} X(\mu) &= \operatorname{Res}_{\mu=\mu_k^+} [(\mu + \frac{1}{2}) Y(\mu)], & 1 \leq k \leq n_1, \\ \operatorname{Res}_{\mu=\mu_k^-} X(\mu) &= \operatorname{Res}_{\mu=\mu_k^-} [(\mu - \frac{1}{2}) Y(\mu)], & 1 \leq k \leq n_2. \end{aligned} \tag{2.4}$$

Equation (2.3) and conditions (2.4) are the problem on three parallel contours for finding either $X(\mu)$ given $Y(\mu)$ or $Y(\mu)$ given $X(\mu)$ at the contour $\operatorname{Re} \mu = 0$. Note that despite functions $X(\mu)$ and $Y(\mu)$ having poles at $\mu = \pm \frac{1}{2}$, the function $P_{-\frac{1}{2}+\mu}^{(1)}(\cosh \xi)$ has nulls at $\mu = \pm \frac{1}{2}$, and consequently, there is no condition such as (2.4) for $\mu = \pm \frac{1}{2}$.

In our work [31], we solved problem (2.3) for functions $X(\mu)$ and $Y(\mu)$ meromorphic in the strip $|\operatorname{Re} \mu| \leq 1$ that had only simple poles at $\mu = \pm \frac{1}{2}$. In this paper, we extend the approach developed in [31] to finding meromorphic functions $X(\mu)$ and $Y(\mu)$ that solve problem (2.3) subject to conditions (2.4) in the case of $X(\mu), Y(\mu) \in \mathcal{M}_{[-1,1]}$.

If $X(\mu) \in \mathcal{M}_{[-1,1]}$ or $Y(\mu) \in \mathcal{M}_{[-1,1]}$ solves (2.3) subject to conditions (2.4), then $X(\mu)$ or $Y(\mu)$ is unique. Indeed, suppose that $X_1(\mu) \in \mathcal{M}_{[-1,1]}$ and $X_2(\mu) \in \mathcal{M}_{[-1,1]}$ both satisfy (2.3) and (2.4), and $X_1(\mu) \neq X_2(\mu)$. Since $\operatorname{Res}_{\mu=\mu_k^+} X_1(\mu) = \operatorname{Res}_{\mu=\mu_k^+} X_2(\mu)$, $k \neq 0$, this means that $X_0(\mu) = X_1(\mu) - X_2(\mu)$ is a solution to the homogeneous equation (2.3) such that $X_0(\mu) \in \mathcal{M}_{[-1,1]}^0$. The same reasoning is applied to the function $Y(\mu)$. Consequently, solutions to homogeneous equations of problem (2.3) subject to conditions (2.4) are from the class $\mathcal{M}_{[-1,1]}^0$, i.e., are the functions meromorphic in the strip $-1 \leq \operatorname{Re} \mu \leq 1$ with simple poles at $\mu = \pm \frac{1}{2}$ only and having exponentially fast convergence at $|\mu| \rightarrow \infty$. In this case, we merely need to restate Proposition 1 [31, p. 1275] and Proposition 2 [31, p. 1278] drawing attention to the fact that in [31], the space $\mathcal{M}_{[-1,1]}$ coincides with $\mathcal{M}_{[-1,1]}^0$.

PROPOSITION 2.1 (Homogeneous solutions). The only $X_0(\mu) \in \mathcal{M}_{[-1,1]}^0$ and $Y_0(\mu) \in \mathcal{M}_{[-1,1]}^0$ that solve the corresponding homogeneous equations for (2.3):

$$X_0(\mu + 1) - 2X_0(\mu) + X_0(\mu - 1) = 0, \quad \operatorname{Re} \mu = 0, \tag{2.5}$$

$$(\mu + \frac{3}{2}) Y_0(\mu + 1) - 2\mu Y_0(\mu) + (\mu - \frac{3}{2}) Y_0(\mu - 1) = 0, \quad \operatorname{Re} \mu = 0, \tag{2.6}$$

subject to (2.4), are zero functions, i.e., $X_0(\mu) \equiv 0$ and $Y_0(\mu) \equiv 0$.

Proof. See proofs of Propositions 1 and 2 in [31, pp. 1275, 1278]. □

This proposition implies that $X(\mu), Y(\mu) \in \mathcal{M}_{[-1,1]}$ solving equation (2.3) are unique.

THEOREM 2.1 (Hilbert formulas in the case of $X(\mu), Y(\mu) \in \mathcal{M}_{[-1,1]}$). Let the real and imaginary parts of an r -analytic function be represented in toroidal coordinates by the Mehler-Fock integrals (1.3) and (1.4), respectively, and let $X(\mu), Y(\mu) \in \mathcal{M}_{[-1,1]}$.

- (1) At the contour $\operatorname{Re} \mu = 0$, the function $X(\mu)$ is represented by the Hilbert formula for the real part of the r -analytic function

$$X(\mu) = \mu Y(\mu) - \frac{i}{2 \cos[\pi\mu]} \int_{-i\infty}^{+i\infty} Y(\nu) \frac{\cos[\pi\nu]}{\sin[\pi(\nu - \mu)]} d\nu, \quad \operatorname{Re} \mu = 0. \tag{2.7}$$

(2) If $\int_{-i\infty}^{+i\infty} X(\mu) d\mu = 0$, then at the contour $\operatorname{Re} \mu = 0$, the function $Y(\mu)$ is represented by the Hilbert formula for the imaginary part of the r -analytic function

$$Y(\mu) = \frac{1}{\mu^2 - \frac{1}{4}} \left(\mu X(\mu) + \frac{i}{2 \cos[\pi\mu]} \int_{-i\infty}^{+i\infty} X(\nu) \frac{\cos[\pi\nu]}{\sin[\pi(\nu - \mu)]} d\nu \right), \quad \operatorname{Re} \mu = 0, \quad (2.8)$$

where the notation \int means the Cauchy principal value or v.p. (*valeur principale*) of a singular integral.

Proof. First, we prove formula (2.7). For $\operatorname{Re} \mu = 0$, equation (2.3) may be rewritten as

$$\begin{aligned} & [X(\mu + 1) - X(\mu)] - [X(\mu) - X(\mu - 1)] \\ &= \left[\left(\mu + \frac{3}{2}\right) Y(\mu + 1) - \left(\mu - \frac{1}{2}\right) Y(\mu) \right] - \left[\left(\mu + \frac{1}{2}\right) Y(\mu) - \left(\mu - \frac{3}{2}\right) Y(\mu - 1) \right]. \end{aligned} \quad (2.9)$$

Introducing a new function $Z(\mu)$ by

$$\begin{aligned} Z(\mu + 1) &= [X(\mu + 1) - X(\mu)] - \left[\left(\mu + \frac{3}{2}\right) Y(\mu + 1) - \left(\mu - \frac{1}{2}\right) Y(\mu) \right], \\ Z(\mu) &= [X(\mu) - X(\mu - 1)] - \left[\left(\mu + \frac{1}{2}\right) Y(\mu) - \left(\mu - \frac{3}{2}\right) Y(\mu - 1) \right], \end{aligned} \quad (2.10)$$

we reduce equation (2.3) to

$$Z(\mu + 1) - Z(\mu) = 0, \quad \operatorname{Re} \mu = 0,$$

where $Z(\mu) \in \mathcal{M}_{[0,1]}^0$, since by virtue of conditions (2.4), the function $Z(\mu)$ does not have poles at $\mu = \mu_k^+$, $1 \leq k \leq n_1$, and $\mu = 1 + \mu_k^-$, $1 \leq k \leq n_2$. This is the same problem as (18) in [31, p. 1275], where it is shown that the only solution to this problem from the class $\mathcal{M}_{[0,1]}^0$ is $Z(\mu) \equiv 0$. (In [31], the space $\mathcal{M}_{[0,1]}$ coincides with $\mathcal{M}_{[0,1]}^0$.) Thus, we have

$$X(\mu + 1) - X(\mu) = \left(\mu + \frac{3}{2}\right) Y(\mu + 1) - \left(\mu - \frac{1}{2}\right) Y(\mu), \quad \operatorname{Re} \mu = 0, \quad (2.11)$$

$$X(\mu) - X(\mu - 1) = \left(\mu + \frac{1}{2}\right) Y(\mu) - \left(\mu - \frac{3}{2}\right) Y(\mu - 1), \quad \operatorname{Re} \mu = 0. \quad (2.12)$$

It is sufficient to solve only (2.11) for $X(\mu) \in \mathcal{M}_{[0,1]}$ given $Y(\mu) \in \mathcal{M}_{[0,1]}$. It can be shown that solutions to (2.11) and (2.12) provide the same $X(\mu)$ at $\operatorname{Re} \mu = 0$.

Representing $X(\mu)$ by

$$X(\mu) = \left(\mu + \frac{1}{2}\right) Y(\mu) + \hat{X}(\mu), \quad (2.13)$$

where \hat{X} is a new function, we reformulate equation (2.11) for $\hat{X}(\mu)$:

$$\hat{X}(\mu + 1) - \hat{X}(\mu) = Y(\mu), \quad \operatorname{Re} \mu = 0. \quad (2.14)$$

According to (2.13), we have

$$\operatorname{Res}_{\mu=\mu_k^+} X(\mu) = \operatorname{Res}_{\mu=\mu_k^+} \left[\left(\mu + \frac{1}{2}\right) Y(\mu) \right] + \operatorname{Res}_{\mu=\mu_k^+} \hat{X}(\mu), \quad 1 \leq k \leq n_1.$$

Taking into account condition (2.4), we see that $\operatorname{Res}_{\mu=\mu_k^+} \hat{X}(\mu) = 0$, $1 \leq k \leq n_1$. But this means that $\hat{X}(\mu)$ has only a simple pole at $\mu = \frac{1}{2}$, that is, $\hat{X}(\mu) \in \mathcal{M}_{[0,1]}^0$. For the class of meromorphic functions, $\mathcal{M}_{[0,1]}^0$, problem (2.14) is solved in [31]. By the conformal mapping $z = i \tan[\pi\mu]$, (2.14) reduces to a Riemann boundary-value problem

for a function meromorphic in the complex plane z with the branch cut along the segment $[-1, 1]$ and having a single simple pole at infinity. For details, see problem (24) in [31, p. 1277] remembering that in [31], $\mathcal{M}_{[0,1]}$ coincides with $\mathcal{M}_{[0,1]}^0$. Within the open strip $0 < \operatorname{Re} \mu < 1$, the function $\hat{X}(\mu) \in \mathcal{M}_{[0,1]}^0$ that solves (2.14) is obtained from a Cauchy-type integral and takes the form

$$\hat{X}(\mu) = -\frac{i}{2 \cos[\pi\mu]} \int_{-i\infty}^{+i\infty} Y(\nu) \frac{\cos[\pi\nu]}{\sin[\pi(\nu - \mu)]} d\nu, \quad \operatorname{Re} \mu \in (0, 1). \tag{2.15}$$

At the contours $\operatorname{Re} \mu = 0$ and $\operatorname{Re} \mu = 1$, the boundary values of the same solution, $\hat{X}(\mu)$, are determined based on the Sokhotski formulas [6, 31] (also known as Sokhotski-Plemelj formulas) and are given by

$$\hat{X}(\mu) = -\frac{1}{2}Y(\mu) - \frac{i}{2 \cos[\pi\mu]} \int_{-i\infty}^{+i\infty} Y(\nu) \frac{\cos[\pi\nu]}{\sin[\pi(\nu - \mu)]} d\nu, \quad \operatorname{Re} \mu = 0 \tag{2.16}$$

and

$$\hat{X}(\mu + 1) = \frac{1}{2}Y(\mu) - \frac{i}{2 \cos[\pi\mu]} \int_{-i\infty}^{+i\infty} Y(\nu) \frac{\cos[\pi\nu]}{\sin[\pi(\nu - \mu)]} d\nu, \quad \operatorname{Re} \mu = 0.$$

Substituting (2.16) into (2.13), we obtain the Hilbert formula (2.7).

To prove formula (2.8), we consider now equation (2.9) with respect to $Y(\mu)$. Repeating the same arguments as in the proof of formula (2.7), we obtain equations (2.11) and (2.12), which we now solve with respect to $Y(\mu)$. It is sufficient to solve equation (2.11) only. It can be shown that the solutions to (2.11) and (2.12) provide the same $Y(\mu)$ at $\operatorname{Re} \mu = 0$. Multiplying (2.11) by $(\mu + \frac{1}{2})$, we represent function $Y(\mu)$ by

$$Y(\mu) = \frac{1}{\mu^2 - \frac{1}{4}} \left(\hat{Y}(\mu) + (\mu - \frac{1}{2}) X(\mu) \right), \tag{2.17}$$

where $\hat{Y}(\mu)$ is a new function. The crucial point here is that $\hat{Y}(\mu)$ belongs to the space of $\mathcal{A}_{[0,1]}$. Indeed, from (2.17), we have

$$\hat{Y}(\mu) = (\mu - \frac{1}{2}) \left((\mu + \frac{1}{2}) Y(\mu) - X(\mu) \right).$$

Based on condition (2.4), we conclude that $\operatorname{Res}_{\mu=\mu_k^+} \hat{Y}(\mu) = 0, 1 \leq k \leq n_1$, and $\operatorname{Res}_{\mu=\frac{1}{2}} \hat{Y}(\mu) =$

0. Consequently, equation (2.11) reduces to a problem for finding the function $\hat{Y}(\mu)$ analytic in $0 \leq \operatorname{Re} \mu \leq 1$ with exponentially fast convergence at $|\mu| \rightarrow \infty$:

$$\hat{Y}(\mu + 1) - \hat{Y}(\mu) = -X(\mu), \quad \operatorname{Re} \mu = 0. \tag{2.18}$$

This problem is similar to (2.14). However, while the function $\hat{X}(\mu)$ in (2.14) has a simple pole at $\mu = \frac{1}{2}$, the function $\hat{Y}(\mu)$ in (2.18) does not. Consequently, integrating equation (2.18) at the contour $\operatorname{Re} \mu = 0$, we obtain $\frac{1}{2\pi i} \int_{-i\infty}^{+i\infty} X(\mu) d\mu = 0$. This means that the function $X(\mu)$ should necessarily satisfy this condition. For the class of analytic functions, $\mathcal{A}_{[0,1]}$, problem (2.18) is the same as (33) in [31, p. 1279] solved by the approach

similar to that for (2.14). Analogously, within the open strip $0 < \operatorname{Re} \mu < 1$, the function $\hat{Y}(\mu) \in \mathcal{A}_{[0,1]}$, satisfying (2.18), is given by a transformed Cauchy-type integral:

$$\hat{Y}(\mu) = \frac{i}{2 \cos[\pi\mu]} \int_{-i\infty}^{+i\infty} X(\nu) \frac{\cos[\pi\nu]}{\sin[\pi(\nu - \mu)]} d\nu, \quad \operatorname{Re} \mu \in (0, 1). \quad (2.19)$$

At the contour $\operatorname{Re} \mu = 0$, the boundary value of the same $\hat{Y}(\mu)$ is determined based on the Sokhotski formulas [6, 31] and takes the form

$$\hat{Y}(\mu) = \frac{1}{2} X(\mu) + \frac{i}{2 \cos[\pi\mu]} \int_{-i\infty}^{+i\infty} X(\nu) \frac{\cos[\pi\nu]}{\sin[\pi(\nu - \mu)]} d\nu, \quad \operatorname{Re} \mu = 0. \quad (2.20)$$

In contrast to (2.15), the function (2.19) has no pole at $\mu = \frac{1}{2}$ by virtue of the condition $\int_{-i\infty}^{+i\infty} X(\nu) d\nu = 0$. Substituting (2.20) into (2.17), we obtain the Hilbert formula (2.8). \square

The Hilbert formulas (2.7) and (2.8) are expressed by singular integrals; consequently, they require special treatment in numerical implementation. We derive formulas for efficiently calculating double integrals in (1.3) with (2.7) and in (1.4) with (2.8).

PROPOSITION 2.2 (Mehler-Fock integrals with Hilbert formulas).

(1) If the function $Y(\mu)$ is represented at $\operatorname{Re} \mu = 0$ by the Hilbert formula (2.8), then the function $\omega(\xi, \eta)$ takes the form

$$\omega(\xi, \eta) = \frac{1}{2\pi i} \sqrt{\cosh \xi - \cos \eta} \int_{-\infty}^{+\infty} X(i\tau) \left(\frac{\tau}{\tau^2 + \frac{1}{4}} P_{-\frac{1}{2}+i\tau}^{(1)}(\cosh \xi) e^{-\eta\tau} + G_1(\xi, \eta, \tau) \right) d\tau, \quad (2.21)$$

where

$$G_1(\xi, \eta, \tau) = \begin{cases} -\frac{\sqrt{2}}{\pi \sinh \xi} \left(e^{-\eta\tau} \int_0^\xi g(\eta, \tau, t) \sqrt{\cosh \xi - \cosh t} dt + 2 h_1(\xi, \eta) \sin \frac{\eta}{2} \right), & \eta \neq 0, \\ -\frac{\sqrt{2}}{\pi \sinh \xi} \int_0^\xi \coth \frac{t}{2} \sin[\tau t] \sqrt{\cosh \xi - \cosh t} dt, & \eta = 0, \end{cases} \quad (2.22)$$

$$g(\eta, \tau, t) = \frac{\sinh t \sin[\tau t] - \sin \eta \cos[\tau t]}{\cosh t - \cos \eta}, \quad (2.23)$$

$$h_1(\xi, \eta) = \frac{\pi}{\sqrt{2}} \left(\sqrt{1 + \frac{\sinh^2 \frac{\xi}{2}}{\sin^2 \frac{\eta}{2}}} - 1 \right), \quad \eta \neq 0. \quad (2.24)$$

Both integrals in (2.22) are regular and can be efficiently calculated by a Gaussian quadrature.

(2) If the function $X(\mu)$ is represented at $\operatorname{Re} \mu = 0$ by the Hilbert formula (2.7), then the function $\theta(\xi, \eta)$ takes the form

$$\theta(\xi, \eta) = \frac{1}{2\pi} \sqrt{\cosh \xi - \cos \eta} \int_{-\infty}^{+\infty} Y(i\tau) \left(\tau P_{-\frac{1}{2}+i\tau}(\cosh \xi) e^{-\eta\tau} - G_2(\xi, \eta, \tau) \right) d\tau, \tag{2.25}$$

where

$$G_2(\xi, \eta, \tau) = \begin{cases} \frac{2\sqrt{2}}{\pi \sinh^2 \xi} \int_0^\xi \left[g(\eta, \tau, t) e^{-\eta\tau} \left(\frac{3}{4} \cosh t + \frac{1}{4} \cosh \xi \right) \sqrt{\cosh \xi - \cosh t} \right. \\ \left. - \frac{1}{3} \frac{\partial^2}{\partial \eta^2} (g(\eta, \tau, t) e^{-\eta\tau}) (\cosh \xi - \cosh t)^{\frac{3}{2}} \right] dt \\ \qquad \qquad \qquad + \frac{1}{\sqrt{2}} \frac{\operatorname{sign} \eta}{\sqrt{\cosh \xi - \cos \eta}}, \quad \eta \neq 0, \\ \frac{2\sqrt{2}}{\pi \sinh^2 \xi} \int_0^\xi \left(\coth \frac{t}{2} \sin[\tau t] \left(\frac{3}{4} \cosh t + \frac{1}{4} \cosh \xi - \frac{1}{2} \right) \right. \\ \left. + \tau \cosh^2 \frac{t}{2} \cos[\tau t] \right) \sqrt{\cosh \xi - \cosh t} dt, \quad \eta = 0, \end{cases} \tag{2.26}$$

and $g(\xi, \tau, t)$ is defined by (2.23). Both integrals in (2.26) are regular and can be efficiently calculated by a Gaussian quadrature.

Proof. The proof of the proposition is given in the appendix and is similar to that of the formulas for Fourier integrals with the Hilbert formulas; see [31]. \square

REMARK 2.2 (Function $\theta(\xi, \eta)$). If we represent $P_{-\frac{1}{2}+i\tau}(\cosh \xi)$ by

$$P_{-\frac{1}{2}+i\tau}(\cosh \xi) = \frac{1}{\pi\sqrt{2}} \cosh[\pi\tau] \int_{-\infty}^{+\infty} \frac{e^{i\tau t}}{\sqrt{\cosh t + \cosh \xi}} dt,$$

see [1], then the function (2.26) takes the form

$$\begin{aligned} G_2(\xi, \eta, \tau_1) &= \frac{\cosh[\pi\tau_1]}{2\pi\sqrt{2}} \int_{-\infty}^{+\infty} \frac{1}{\sqrt{\cosh t + \cosh \xi}} \left(\int_{-\infty}^{+\infty} \frac{e^{\tau(it-\eta)} d\tau}{\sinh[\pi(\tau_1 - \tau)]} \right) dt \\ &= \frac{\cosh[\pi\tau_1] e^{-\tau_1\eta}}{\pi\sqrt{2}} \int_0^{+\infty} \frac{\cos[\tau_1 t] \sin \eta + \sin[\tau_1 t] \sinh t}{(\cosh t + \cos \eta) \sqrt{\cosh t + \cosh \xi}} dt. \end{aligned} \tag{2.27}$$

Expression (2.27) is simpler than (2.26). However, though (2.27) is a regular integral, it is a Fourier integral on an infinite interval. Consequently, from a computational point of view, the representation (2.26) is preferable. We used formula (2.27) to verify (2.26) numerically.

3. Axially symmetric Stokes flow about a biconvex lens-shaped body. Let us consider the axially symmetric steady motion of a rigid biconvex lens-shaped body in a Stokes fluid. In this case, the velocity vector of the fluid particles, \mathbf{u} , satisfies the Stokes model (0.1). Suppose that the body moves in the fluid with constant velocity V_0 along its axis of symmetry; see Figure 2. Let (r, φ, z) be a system of cylindrical coordinates

with basis $(\mathbf{e}_r, \mathbf{e}_\varphi, \mathbf{k})$ such that the z -axis determines the body's axis of symmetry. Then the boundary conditions for \mathbf{u} are determined on the surface S of the body by

$$\mathbf{u}|_S = V_0 \mathbf{k}. \quad (3.1)$$

We assume that the velocity \mathbf{u} and the pressure function θ vanish at infinity:

$$\mathbf{u}|_\infty = 0, \quad \theta|_\infty = 0. \quad (3.2)$$

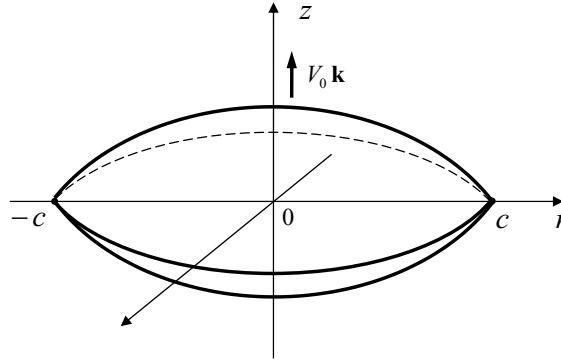

FIG. 2. Axially symmetric motion of a rigid biconvex lens-shaped body

The boundary-value problem (0.1), (3.1) and (3.2) is a classical problem in the hydrodynamics of Stokes flows [10, 14, 24]. Since we consider only axially symmetric motion, the boundary conditions (3.1) are reformulated for the components of the vector \mathbf{u} in cylindrical coordinates as:

$$u_r(r, z)|_{\eta=\pm\eta_0} = 0, \quad u_\varphi(r, z) \equiv 0, \quad u_z(r, z)|_{\eta=\pm\eta_0} = V_0, \quad (3.3)$$

where $\eta = \eta_0$ and $\eta = -\eta_0$ determine the contour of the biconvex lens-shaped body in toroidal coordinates (ξ, η) in the meridional cross-section (r, z) -plane (see Figure 1).

The problem of the steady motion of a rigid body in a Stokes fluid is closely related to the problem of the Stokes flow about the body immersed in the viscous fluid [10]. The only difference is that in the latest problem, the body is immersed in the uniform flow, and the velocity of the flow is assumed to be constant at infinity. In this case, the boundary conditions take the form: $\tilde{\mathbf{u}}|_S = 0$ and $\tilde{\mathbf{u}}|_\infty = -V_0 \mathbf{k}$, where $\tilde{\mathbf{u}}$ is the velocity of the Stokes flow in this problem. Obviously, the velocities \mathbf{u} and $\tilde{\mathbf{u}}$ are related by $\tilde{\mathbf{u}} = \mathbf{u} - V_0 \mathbf{k}$.

3.1. Stream function approach. A classical approach to solving axially symmetric problems of Stokes flows is to represent the vector \mathbf{u} by a stream function $\Psi(r, z)$ in cylindrical coordinates [24]:

$$\mathbf{u} = -\text{curl}(\Psi \mathbf{e}_\varphi). \quad (3.4)$$

In component form, (3.4) is rewritten as:

$$u_r(r, z) = \frac{1}{r} \frac{\partial}{\partial z} (r \Psi), \quad u_\varphi(r, z) \equiv 0, \quad u_z(r, z) = -\frac{1}{r} \frac{\partial}{\partial r} (r \Psi). \quad (3.5)$$

The stream function Ψ is different from the stream function, Ψ_P , introduced by Payne and Pell [16] as $u_r = -\frac{1}{r} \frac{\partial \Psi_P}{\partial z}$, $u_z = \frac{1}{r} \frac{\partial \Psi_P}{\partial r}$ in the problem of the Stokes flow about

a body immersed in a viscous fluid. If the velocity of the Stokes flow at infinity in Payne and Pell’s problem is $-V_0 \mathbf{k}$, then the stream functions Ψ and Ψ_P are related by $\Psi_P = -(r\Psi + \frac{1}{2}V_0 r^2)$.

The stream function Ψ satisfies a so-called bi-1-harmonic equation

$$\Delta_1^2 \Psi(r, z) = 0, \tag{3.6}$$

where the 1-harmonic operator Δ_1 is defined by (0.6). Based on (3.3) and (3.5), we formulate the boundary conditions for the stream function Ψ as

$$\left(\frac{\partial}{\partial r}(r\Psi)\right)\Big|_{\eta=\pm\eta_0} = -V_0 r|_{\eta=\pm\eta_0}, \quad \left(\frac{\partial}{\partial z}(r\Psi)\right)\Big|_{\eta=\pm\eta_0} = 0. \tag{3.7}$$

Using relations (1.2), we have

$$\left(\frac{\partial}{\partial \xi}(r\Psi)\right)\Big|_{\eta=\pm\eta_0} = V_0 c^2 \frac{\sinh \xi (\cosh \xi \cos \eta - 1)}{(\cosh \xi - \cos \eta)^3} \Big|_{\eta=\pm\eta_0}, \tag{3.8}$$

$$\left(\frac{\partial}{\partial \eta}(r\Psi)\right)\Big|_{\eta=\pm\eta_0} = V_0 c^2 \frac{\sinh^2 \xi \sin \eta}{(\cosh \xi - \cos \eta)^3} \Big|_{\eta=\pm\eta_0}. \tag{3.9}$$

From (3.8) we obtain

$$\begin{aligned} (r\Psi)\Big|_{\eta=\pm\eta_0} &= V_0 c^2 \left(-\frac{\cos \eta}{\cosh \xi - \cos \eta} + \frac{1}{2} \frac{\sin^2 \eta}{(\cosh \xi - \cos \eta)^2} \right) \Big|_{\eta=\pm\eta_0} + \lambda \\ &= \frac{V_0}{2} (c^2 - r^2) \Big|_{\eta=\pm\eta_0} + \lambda = -\frac{V_0}{2} r^2 \Big|_{\eta=\pm\eta_0}, \end{aligned}$$

where $\lambda = -\frac{V_0 c^2}{2}$ is the constant of integration that provides finiteness of $\Psi|_{\eta=\pm\eta_0}$ at $\xi \rightarrow 0$. Consequently,

$$\Psi|_{\eta=\pm\eta_0} = -\frac{V_0}{2} r|_{\eta=\pm\eta_0}, \tag{3.10}$$

and from (3.9) and (3.10), we have

$$\frac{\partial \Psi}{\partial \eta} \Big|_{\eta=\pm\eta_0} = \frac{V_0 c}{2} \frac{\sinh \xi \sin \eta}{(\cosh \xi - \cos \eta)^2} \Big|_{\eta=\pm\eta_0}. \tag{3.11}$$

We represent the stream function Ψ as the sum of the stream function for the sphere, $\eta_0 = \frac{\pi}{2}$, and an auxiliary stream function $\hat{\Psi}$:

$$\Psi(r, z) = \Psi_{\text{sphere}}(r, z) + \hat{\Psi}(r, z), \tag{3.12}$$

where

$$\begin{aligned} \Psi_{\text{sphere}}(r, z) &= \frac{cV_0}{4} \frac{r}{\sqrt{r^2 + z^2}} \left(\frac{c^2}{r^2 + z^2} - 3 \right), \\ \hat{\Psi}(r, z) &= z \Phi_0(r, z) + \frac{1}{2} (r^2 + z^2 - c^2) \Phi_1(r, z), \end{aligned} \tag{3.13}$$

and $\Phi_0(r, z)$ and $\Phi_1(r, z)$ are 1-harmonic functions:

$$\Delta_1 \Phi_0(r, z) = 0, \quad \Delta_1 \Phi_1(r, z) = 0.$$

The form of (3.12) for Ψ is chosen based on the fact that from (3.10), $\Psi|_{\eta=\pm\eta_0} \neq 0$ at $\xi \rightarrow \infty$. As we will see further, form (3.12) provides $\hat{\Psi}\Big|_{\eta=\pm\eta_0} \rightarrow 0$ at $\xi \rightarrow \infty$, which

is necessary for representing boundary conditions for $\hat{\Psi}$ in the form of Mehler-Fock integrals.

In toroidal coordinates (ξ, η) , functions Φ_0 and Φ_1 are represented by Mehler-Fock integrals:

$$\Phi_0(\xi, \eta) = \frac{1}{2\pi ic} \sqrt{\cosh \xi - \cos \eta} \int_{-i\infty}^{+i\infty} A(\mu) \sin[\eta\mu] P_{-\frac{1}{2}+\mu}^{(1)}(\cosh \xi) d\mu, \quad -\eta_0 \leq \eta \leq \eta_0, \quad (3.14)$$

$$\Phi_1(\xi, \eta) = \frac{1}{2\pi ic^2} \sqrt{\cosh \xi - \cos \eta} \int_{-i\infty}^{+i\infty} B(\mu) \cos[\eta\mu] P_{-\frac{1}{2}+\mu}^{(1)}(\cosh \xi) d\mu, \quad -\eta_0 \leq \eta \leq \eta_0, \quad (3.15)$$

where $A(\mu)$ and $B(\mu)$ are meromorphic functions in the strip $-1 \leq \operatorname{Re} \mu \leq 1$, and

$$\begin{aligned} A(-\mu) &= -A(\mu), \\ B(-\mu) &= B(\mu). \end{aligned}$$

Representations (3.14) and (3.15) reduce the function $\hat{\Psi}$ to the form

$$\hat{\Psi}(\xi, \eta) = \frac{1}{2\pi i \sqrt{\cosh \xi - \cos \eta}} \int_{-i\infty}^{+i\infty} \begin{pmatrix} A(\mu) \sin \eta \sin[\eta\mu] \\ +B(\mu) \cos \eta \cos[\eta\mu] \end{pmatrix} P_{-\frac{1}{2}+\mu}^{(1)}(\cosh \xi) d\mu. \quad (3.16)$$

To simplify the calculation, we introduce a new function

$$\tilde{\Psi}(\xi, \eta) = 2\pi i \sqrt{\cosh \xi - \cos \eta} \hat{\Psi}(\xi, \eta),$$

and reformulate the boundary conditions (3.10) and (3.9) for $\tilde{\Psi}$:

$$\tilde{\Psi} \Big|_{\eta=\pm\eta_0} = \pi i V_0 c \left(\frac{\sinh \xi \cos \eta}{(\cosh \xi + \cos \eta)^{\frac{3}{2}}} + \frac{\sinh \xi}{\sqrt{\cosh \xi + \cos \eta}} - \frac{\sinh \xi}{\sqrt{\cosh \xi - \cos \eta}} \right) \Big|_{\eta=\pm\eta_0}, \quad (3.17)$$

$$\begin{aligned} \frac{\partial \tilde{\Psi}}{\partial \eta} \Big|_{\eta=\pm\eta_0} &= \frac{\pi i V_0 c}{2} \left(\frac{\sinh \xi \sin \eta}{(\cosh \xi - \cos \eta)^{\frac{3}{2}}} - \frac{\sinh \xi \sin \eta}{(\cosh \xi + \cos \eta)^{\frac{3}{2}}} \right. \\ &\quad \left. + 3 \frac{\sinh \xi \sin \eta \cos \eta}{(\cosh \xi + \cos \eta)^{\frac{5}{2}}} \right) \Big|_{\eta=\pm\eta_0}. \end{aligned} \quad (3.18)$$

To represent the right-hand sides of (3.17) and (3.18) in the form of Mehler-Fock integrals, we use the following representations [20]:

$$\begin{aligned} \frac{\sinh \xi}{(\cosh \xi + \cos \eta)^{\frac{3}{2}}} &= i\sqrt{2} \int_{-i\infty}^{+i\infty} \frac{\cos[\eta\mu]}{\cos[\pi\mu]} P_{-\frac{1}{2}+\mu}^{(1)}(\cosh \xi) d\mu, \quad -\pi < \eta < \pi, \\ \frac{\sinh \xi}{(\cosh \xi - \cos \eta)^{\frac{3}{2}}} &= i\sqrt{2} \int_{-i\infty}^{+i\infty} \frac{\cos[(\pi - \eta)\mu]}{\cos[\pi\mu]} P_{-\frac{1}{2}+\mu}^{(1)}(\cosh \xi) d\mu, \quad 0 < \eta < 2\pi, \end{aligned}$$

$$\frac{\sinh \xi}{\sqrt{\cosh \xi + \cos \eta}} - \frac{\sinh \xi}{\sqrt{\cosh \xi - \cos \eta}} = i\sqrt{2} \int_{-i\infty}^{+i\infty} \frac{\cos[\frac{\pi\mu}{2}]}{(\mu^2 - 1) \cos[\pi\mu]} P_{-\frac{1}{2}+\mu}^{(1)}(\cosh \xi) \times \begin{pmatrix} \cos \eta \cos [(\frac{\pi}{2} - \eta) \mu] \\ -\mu \sin \eta \sin [(\frac{\pi}{2} - \eta) \mu] \end{pmatrix} d\mu.$$

Consequently, the boundary conditions (3.17) and (3.18) reduce to a system of linear equations with respect to $A(\mu)$ and $B(\mu)$:

$$\begin{pmatrix} \sin \eta_0 \sin[\eta_0\mu] & \cos \eta_0 \cos[\eta_0\mu] \\ \cos \eta_0 \sin[\eta_0\mu] & -\sin \eta_0 \cos[\eta_0\mu] \\ +\mu \sin \eta_0 \cos[\eta_0\mu] & -\mu \cos \eta_0 \sin[\eta_0\mu] \end{pmatrix} \begin{pmatrix} A(\mu) \\ B(\mu) \end{pmatrix} = -\frac{\pi\sqrt{2} V_0 c}{\cos[\pi\mu]} \begin{pmatrix} \cos \eta_0 \cos[\eta_0\mu] + \frac{\cos[\frac{\pi\mu}{2}]}{(\mu^2-1)} & (\cos \eta_0 \cos [(\frac{\pi}{2} - \eta_0) \mu] \\ -\mu \sin \eta_0 \sin [(\frac{\pi}{2} - \eta_0) \mu]) \\ -\sin \eta_0 \sin [\frac{\pi\mu}{2}] \sin [(\frac{\pi}{2} - \eta_0) \mu] - \mu \cos \eta_0 \sin[\eta_0\mu] \end{pmatrix} \tag{3.19}$$

The determinant of system (3.19), $D(\mu)$, and functions $A(\mu)$ and $B(\mu)$ take the form

$$D(\mu) = -\frac{1}{2} (\mu \sin[2\eta_0] + \sin[2\eta_0\mu]), \tag{3.20}$$

$$A(\mu) = -\frac{\pi\sqrt{2} V_0 c \mu}{(\mu^2 - 1)} \left(\frac{1}{2 \cos[\pi\mu]} + \frac{\cos[(\pi - \eta_0)\mu]}{2 \cos[\pi\mu] \cos[\eta_0\mu]} - \tan[\pi\mu] \frac{(\sin^2 \eta_0 + \frac{1}{2}\mu \tan[\eta_0\mu] \sin[2\eta_0])}{\mu \sin[2\eta_0] + \sin[2\eta_0\mu]} \right), \tag{3.21}$$

$$B(\mu) = -\frac{\pi\sqrt{2} V_0 c}{(\mu^2 - 1)} \left(\frac{\mu^2 - \frac{1}{2}}{\cos[\pi\mu]} + \frac{\cos[(\pi - \eta_0)\mu]}{2 \cos[\pi\mu] \cos[\eta_0\mu]} - \mu \tan[\pi\mu] \frac{(\mu \sin^2 \eta_0 + \frac{1}{2} \tan[\eta_0\mu] \sin[2\eta_0])}{\mu \sin[2\eta_0] + \sin[2\eta_0\mu]} \right). \tag{3.22}$$

Consequently, the velocity vector, \mathbf{u} , that solves problem (0.1), (3.1) and (3.2) is expressed analytically by (3.5), (3.12), (3.16), (3.21) and (3.22). As an illustration to the solution of this problem, we calculated streamlines about the rigid biconvex lens-shaped body determined by the equation

$$r \Psi(r, z) + \frac{1}{2} V_0 r^2 = C \tag{3.23}$$

with respect to pairs (r, z) for different values of the constant C . It should be noted that equation (3.23), in fact, determines streamlines about the body immersed in the uniform Stokes flow with the constant velocity, $-V_0 \mathbf{k}$, at infinity, while the stream function Ψ corresponds to the motion of the body with the constant velocity $V_0 \mathbf{k}$. We obtain equation (3.23) based on the fact that in terms of Payne and Pell's stream function, Ψ_P , streamlines are defined by $\Psi_P = \text{constant}$, and that Ψ and Ψ_P are related by $\Psi_P = -(r \Psi + \frac{1}{2} V_0 r^2)$. We used *MATHEMATICA 5* to solve equation (3.23). Figure 3

shows streamlines about the rigid biconvex lens-shaped body for $\eta_0 = \frac{2\pi}{3}$ and $\eta_0 = \frac{\pi}{3}$. Streamlines may also be calculated based on the relation $\frac{dr}{dz} = u_r / (u_z - V_0)$; see [10, 32].

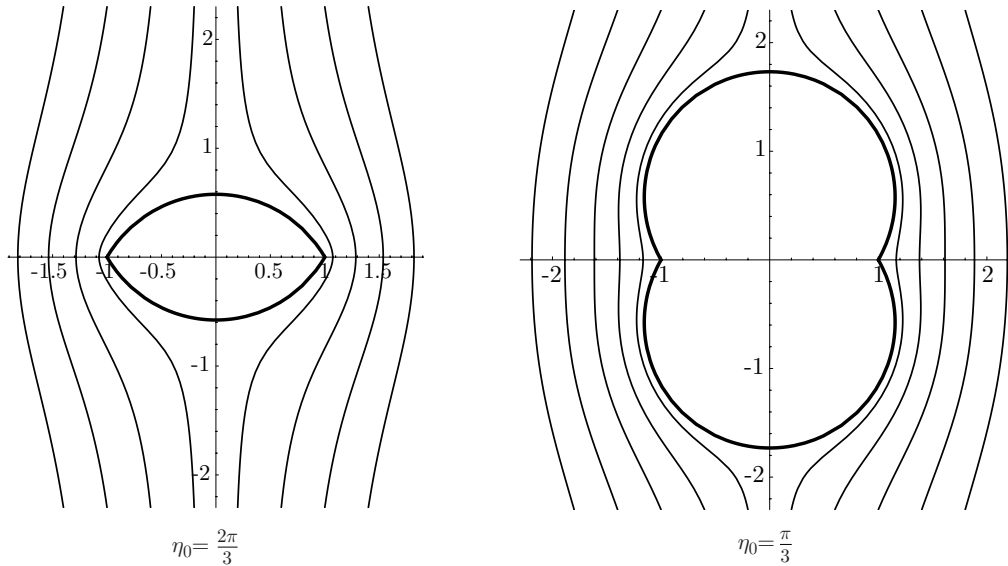

FIG. 3. Streamlines about a rigid biconvex lens-shaped body for $\eta_0 = \frac{2\pi}{3}$ and $\eta_0 = \frac{\pi}{3}$, respectively

The asymptotic behavior of functions (3.14) and (3.15) at $\xi \rightarrow \infty$ is determined by the zeros of determinant (3.20). The function $D(\mu)$ is even, i.e., $D(-\mu) = D(\mu)$, and equals zero at $\mu = 0$ and $\mu = \pm\frac{1}{2}$ for all $\eta_0 \in (0, \pi)$. We call these values generic roots for $D(\mu)$. However, functions $A(\mu)$ and $B(\mu)$ take on finite values at $\mu = 0$, that is $\mu = 0$ is not a pole, and since the function $P_{-\frac{1}{2}+\mu}^{(1)}(\cosh \xi)$ has nulls at $\mu = \pm\frac{1}{2}$, expressions $A(\mu)P_{-\frac{1}{2}+\mu}^{(1)}(\cosh \xi)$ and $B(\mu)P_{-\frac{1}{2}+\mu}^{(1)}(\cosh \xi)$ do not have poles at $\mu = \pm\frac{1}{2}$. Except for the generic roots, the determinant $D(\mu)$ has individual roots for any $\eta_0 \in (0, \pi)$. Table 1 presents the first individual root, μ_0 , for different η_0 .

TABLE 1. First individual root for $D(\mu)$

η_0	μ_0	η_0	μ_0
$\pi/12$	$8.063 + i 4.203$	$7\pi/12$	0.752
$2\pi/12$	$4.059 + i 1.952$	$8\pi/12$	0.616
$3\pi/12$	$2.740 + i 1.119$	$9\pi/12$	0.544
$4\pi/12$	$2.094 - i 0.605$	$10\pi/12$	0.512
$5\pi/12$	1.534	$11\pi/12$	0.501
$6\pi/12$	1.0^\dagger	$12\pi/12$	0.5

† Functions $A(\mu)$ and $B(\mu)$ take on finite values at $\mu = 1$.

The asymptotic behavior of $A(i\tau)$ and $B(i\tau)$ at $\tau \rightarrow \infty$ is determined by

$$A(i\tau)|_{\tau \rightarrow \infty} \sim \frac{\pi\sqrt{2} V_0 c i}{\tau} \left(e^{-\pi|\tau|} + (|\tau| \sin[2\eta_0] + \cos[2\eta_0]) e^{-2\eta_0|\tau|} \right),$$

$$B(i\tau)|_{\tau \rightarrow \infty} \sim \pi\sqrt{2} V_0 c \left(-2e^{-\pi|\tau|} + \left(2 \sin^2 \eta_0 + \frac{\sin[2\eta_0]}{|\tau|} \right) e^{-2\eta_0|\tau|} \right).$$

For the case of the sphere, $\eta_0 = \frac{\pi}{2}$, the functions $D(\mu)$, $A(\mu)$ and $B(\mu)$ take the form

$$D(\mu) = -\frac{1}{2} \sin[\pi\mu], \quad A(\mu) \equiv 0, \quad B(\mu) \equiv 0.$$

4. Hilbert formulas in the hydrodynamics of Stokes flows. In this section, we analyze basic hydrodynamic characteristics: vorticity, pressure and drag force. We use the Hilbert formula (2.7) for the analytic representation of the pressure function θ via a vortex function.

4.1. *Vorticity and scalar vortex function.* The vorticity, ω , is defined by (0.2). In the case of axially symmetric boundary-value conditions, it may be represented as

$$\omega = -\operatorname{curl}(\operatorname{curl}(\Psi \mathbf{e}_\varphi)) = \omega(r, z) \mathbf{e}_\varphi,$$

where $\omega(r, z)$ is a scalar vortex function given by

$$\omega(r, z) = \Delta_1 \Psi(r, z).$$

Since the stream function Ψ is bi-1-harmonic, the vortex function $\omega(r, z)$ is a 1-harmonic function, i.e., $\Delta_1 \omega = 0$, and in terms of the functions Φ_0 and Φ_1 , it takes the form

$$\omega(r, z) = \omega_{\text{sphere}}(r, z) + 2 \frac{\partial \Phi_0}{\partial z} + 2 \left(r \frac{\partial}{\partial r} + z \frac{\partial}{\partial z} \right) \Phi_1 + 3 \Phi_1, \tag{4.1}$$

where

$$\omega_{\text{sphere}}(r, z) = \frac{3}{2} V_0 c \frac{r}{(r^2 + z^2)^{\frac{3}{2}}}.$$

Consequently, the representation of ω by $A(\mu)$ and $B(\mu)$ is straightforward. At the contour $\eta = \eta_0$, the function ω is determined by

$$\omega(\xi, \eta)|_{\eta=\eta_0} = \frac{V_0 \sqrt{2}}{ic} (\cosh \xi - \cos \eta_0)^{\frac{3}{2}} \int_{-i\infty}^{+i\infty} \frac{\mu \tan[\pi\mu] \sin \eta_0 \sin[\eta_0\mu]}{\mu \sin[2\eta_0] + \sin[2\eta_0\mu]} P_{-\frac{1}{2}+\mu}^{(1)}(\cosh \xi) d\mu.$$

Figure 4 illustrates the behavior of $\frac{c}{2V_0} \omega(\xi, \eta)|_{\eta=\eta_0}$ for $\eta_0 = \frac{2\pi}{3}$ and $\eta_0 = \frac{\pi}{3}$.

4.2. *Pressure.* We associate the function θ in the Stokes model (0.1) with the pressure in a Stokes fluid. In an axially symmetric case, the pressure θ and the vortex function ω are independent of the angular coordinate φ and may be considered as real and imaginary parts of an r -analytic function $F(r, z) = \theta(r, z) + i r \omega(r, z)$ that satisfies the generalized Cauchy-Riemann system (0.4). Consequently, we may use the Hilbert formula (2.7) to express θ via ω .

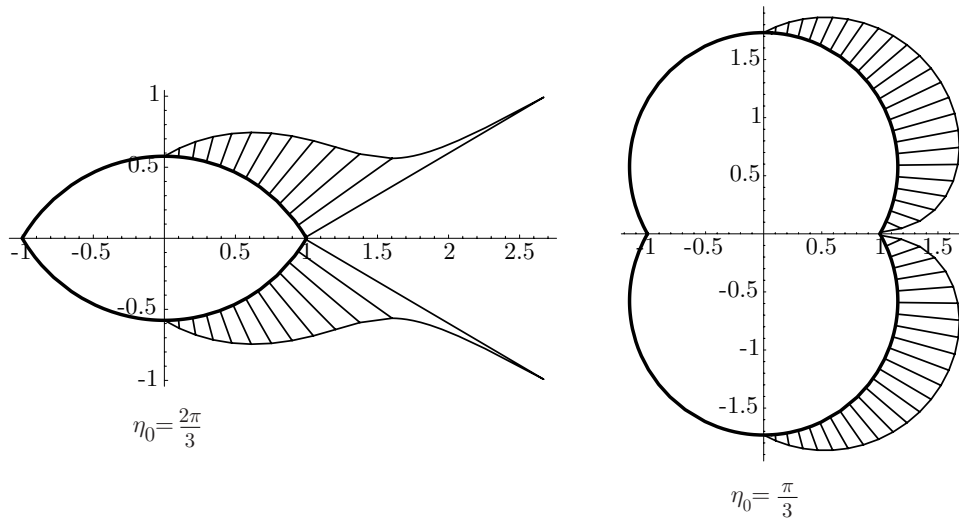

FIG. 4. Épreuves of the vortex function, $\frac{c}{2V_0} \omega(\xi, \eta)|_{\eta=\eta_0}$, at the surface of a rigid biconvex lens-shaped body for $\eta_0 = \frac{2\pi}{3}$ and $\eta_0 = \frac{\pi}{3}$, respectively. At a particular point on the contour, the value of the function is depicted by the length of the outward normal line if the value is positive and by the length of the inward normal line if the value is negative.

PROPOSITION 4.1 (Pressure). Let the vortex function ω be determined by (4.1). Then the pressure θ is a real-valued function represented by

$$\begin{aligned}
 \theta(\xi, \eta) = & \frac{1}{\pi c^2} \sqrt{\cosh \xi - \cos \eta} \left(\frac{3}{2} \frac{\pi V_0 c \sin \eta}{(\cosh \xi + \cos \eta)^{\frac{3}{2}}} - \frac{3}{2} \int_{-\infty}^{+\infty} B(i\tau) G_2(\xi, \eta, \tau) d\tau \right. \\
 & + \sinh \xi \int_{-\infty}^{+\infty} \left(\begin{array}{l} \tilde{A}(i\tau) \left(\frac{1}{2} \cos \eta \sinh[\eta\tau] - \tau \sin \eta \cosh[\eta\tau] \right) \\ + B(i\tau) \left(\frac{1}{2} \sin \eta \cosh[\eta\tau] + \tau \cos \eta \sinh[\eta\tau] \right) \end{array} \right) \\
 & \qquad \qquad \qquad \times P_{-\frac{1}{2}+i\tau}^{(1)}(\cosh \xi) d\tau \\
 & + \cosh \xi \int_{-\infty}^{+\infty} \left(\tilde{A}(i\tau) \cos \eta \sinh[\eta\tau] + B(i\tau) \sin \eta \cosh[\eta\tau] \right) \\
 & \qquad \qquad \qquad \times \left(\tau^2 + \frac{1}{4} \right) P_{-\frac{1}{2}+i\tau}(\cosh \xi) d\tau \\
 & \left. - \int_{-\infty}^{+\infty} \left(\left(\tau^2 + \frac{1}{4} \right) \tilde{A}(i\tau) + \frac{3}{2} \tau B(i\tau) \right) \sinh[\eta\tau] P_{-\frac{1}{2}+i\tau}(\cosh \xi) d\tau \right), \tag{4.2}
 \end{aligned}$$

where $\tilde{A}(i\tau) = -iA(i\tau)$, and $G_2(\xi, \eta, \tau)$ is determined by (2.26), which can be efficiently calculated by a Gaussian quadrature.

Proof. Using representation (4.1) and the fact that $\Delta \Phi_0 = 0$ and $\Delta_1 \Phi_1 = 0$, we obtain the identities

$$\begin{aligned} \frac{\partial \omega}{\partial z} &\equiv \frac{\partial}{\partial z} \left[\omega_{\text{sphere}}(r, z) + 2 \frac{\partial \Phi_0}{\partial z} + 2 \left(r \frac{\partial}{\partial r} + z \frac{\partial}{\partial z} \right) \Phi_1 + 3 \Phi_1 \right] \\ &= \frac{\partial}{\partial r} \left[\theta_{\text{sphere}}(r, z) - \frac{2}{r} \frac{\partial}{\partial r} (r \Phi_0) + 2 \left(r \frac{\partial \Phi_1}{\partial z} - \frac{z}{r} \frac{\partial}{\partial r} (r \Phi_1) \right) \right] + 3 \frac{\partial \Phi_1}{\partial z}, \\ -\frac{1}{r} \frac{\partial}{\partial r} (r \omega) &\equiv -\frac{1}{r} \frac{\partial}{\partial r} \left(r \left[\omega_{\text{sphere}}(r, z) + 2 \frac{\partial \Phi_0}{\partial z} + 2 \left(r \frac{\partial}{\partial r} + z \frac{\partial}{\partial z} \right) \Phi_1 + 3 \Phi_1 \right] \right) \\ &= \frac{\partial}{\partial z} \left[\theta_{\text{sphere}}(r, z) - \frac{2}{r} \frac{\partial}{\partial r} (r \Phi_0) + 2 \left(r \frac{\partial \Phi_1}{\partial z} - \frac{z}{r} \frac{\partial}{\partial r} (r \Phi_1) \right) \right] - 3 \frac{1}{r} \frac{\partial}{\partial r} (r \Phi_1), \end{aligned}$$

where

$$\theta_{\text{sphere}}(r, z) = \frac{3}{2} V_0 c \frac{z}{(r^2 + z^2)^{\frac{3}{2}}}.$$

Based on the relation $\frac{\partial \theta}{\partial r} = \frac{\partial \omega}{\partial z}$ from (0.4), we represent the pressure function θ by

$$\theta(r, z) = \theta_{\text{sphere}} - \frac{2}{r} \frac{\partial}{\partial r} (r \Phi_0) + 2 \left(r \frac{\partial \Phi_1}{\partial z} - \frac{z}{r} \frac{\partial}{\partial r} (r \Phi_1) \right) + 3 \tilde{\theta}(r, z) + \tilde{c}, \quad \tilde{c} = 0, \quad (4.3)$$

where $\tilde{\theta} = \tilde{\theta}(r, z)$ is a new function, and \tilde{c} is a constant. Consequently, system (0.4) for the functions θ and ω reduces to the generalized Cauchy-Riemann system for the functions $\tilde{\theta}$ and Φ_1 , i.e.,

$$\frac{\partial \tilde{\theta}}{\partial r} = \frac{\partial \Phi_1}{\partial z}, \quad \frac{\partial \tilde{\theta}}{\partial z} = -\frac{1}{r} \frac{\partial}{\partial r} (r \Phi_1).$$

This means that $\tilde{F}(r, z) = \tilde{\theta}(r, z) + i r \Phi_1(r, z)$ is an r -analytic function. In an axially symmetric case, $\theta(\xi, -\eta) = -\theta(\xi, \eta)$, $\Phi_0(\xi, -\eta) = -\Phi_0(\xi, \eta)$, $\Phi_1(\xi, -\eta) = \Phi_1(\xi, \eta)$ and $\tilde{\theta}(\xi, -\eta) = -\tilde{\theta}(\xi, \eta)$. Consequently, the left-hand side in (4.3) can be an odd function with respect to η only if $\tilde{c} = 0$.

Recall that the function Φ_1 is represented by the Mehler-Fock integral (3.15) with the density $B(\mu)$ determined by (3.22). The function $B(\mu)$ is meromorphic within the strip $-1 \leq \text{Re } \mu \leq 1$ with only simple poles at $\mu = \pm \frac{1}{2}$ and $\mu = \pm \mu_0$, i.e., it belongs to the space $\mathcal{M}_{[-1,1]}$. Let $\tilde{\theta}$ be represented by the Mehler-Fock integral (1.3) with density $X(\mu) \in \mathcal{M}_{[-1,1]}$. Consequently, the functions $B(\mu)$ and $X(\mu)$ satisfy the conditions of Theorem 2.1. We use the Hilbert formula (2.7) to represent $X(i\tau)$ by $B(i\tau)$ and then express (4.3) in terms of $A(i\tau)$ and $B(i\tau)$, where $\tau \in \mathbb{R}$. \square

As an illustration to formula (4.2), Figure 5 depicts graphs of $\frac{c}{V_0} \theta(\xi, \eta)|_{\eta=\eta_0}$ at the contour of the biconvex lens-shaped body for $\eta_0 = \frac{\pi}{3}$ and $\eta_0 = \frac{2\pi}{3}$. Figures 6 and 7 show épures of the pressure, $\frac{c}{V_0} \theta(\xi, \eta)|_{\eta=\eta_0}$, at the contour of the body and isobars about the body for $\eta_0 = \frac{\pi}{3}$ and $\eta_0 = \frac{2\pi}{3}$, respectively. Isobars are determined by equation $\theta(\xi, \eta) = C$ for different values of the constant C . To solve this equation numerically, we represented $\theta(\xi, \eta)$ by (4.2) and used *MATHEMATICA 5*. An alternative approach for computing isobars is based on the fact that at an isobar:

$$d\theta = \frac{\partial \theta}{\partial r} dr + \frac{\partial \theta}{\partial z} dz = 0.$$

Consequently, using system (0.4), we obtain the explicit first-order differential equation

$$\frac{dz}{dr} = - \frac{\partial \theta}{\partial r} / \frac{\partial \theta}{\partial z} = \frac{\partial \omega}{\partial z} / \frac{1}{r} \frac{\partial}{\partial r} (r\omega),$$

which can be solved by Runge-Kutta methods. We compared both approaches with respect to running time and accuracy. In comparison to the alternative approach, solving $\theta(\xi, \eta) = C$ is faster and more accurate. This proves the superiority of the analytical solution based on the Hilbert formula.

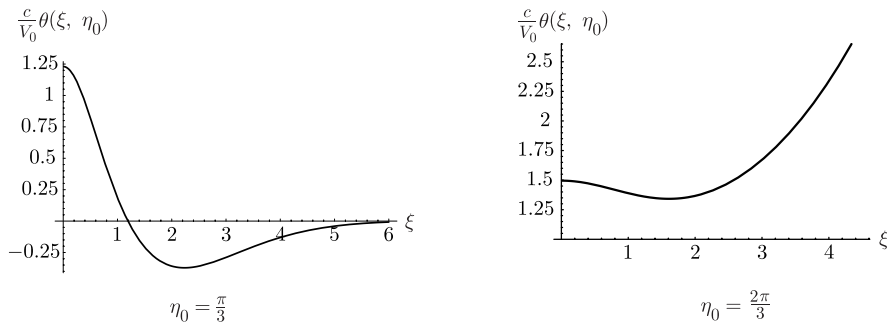

FIG. 5. Function $\frac{c}{V_0} \theta(\xi, \eta_0)$ at the surface of a rigid biconvex lens-shaped body for $\eta_0 = \frac{\pi}{3}$ and $\eta_0 = \frac{2\pi}{3}$, respectively

4.3. *Drag force.* The drag force is the characteristic that attracts most of the attention devoted to problems of motion of rigid bodies in a viscous fluid [10]. An approximate calculation of the drag force by means of variational principles is discussed in [11]. We derive an analytical formula for the drag force exerted on the rigid biconvex lens-shaped body using expressions for the pressure and vortex functions obtained in the previous sections.

PROPOSITION 4.2 (Drag force). The magnitude of the force exerted by a Stokes fluid on the biconvex lens-shaped body is determined by

$$F_0 = 6\pi\rho V_0 c \left(\frac{\pi}{4} + \frac{4}{3} \int_0^{+\infty} \frac{\tau^2 + \frac{1}{4}}{\tau^2 + 1} \left(\frac{\cosh[(\pi - \eta_0)\tau]}{2 \cosh[\pi\tau] \cosh[\eta_0\tau]} + \tau \tanh[\pi\tau] \frac{(\tau \sin^2 \eta_0 + \frac{1}{2} \tanh[\eta_0\tau] \sin[2\eta_0])}{\tau \sin[2\eta_0] + \sinh[2\eta_0\tau]} \right) d\tau \right), \quad (4.4)$$

where ρ is the shear viscosity.

Proof. Let $\mathbf{n} = n_r \mathbf{e}_r + n_z \mathbf{k}$ be the outer normal to the surface of the body, S , where $(\mathbf{e}_r, \mathbf{e}_\varphi, \mathbf{k})$ is the basis of the system of cylindrical coordinates. By definition, $n_r = \frac{\partial r}{\partial n}$ and $n_z = \frac{\partial z}{\partial n}$. The force exerted by the fluid on the elementary surface dS with the normal \mathbf{n} is given by

$$\frac{1}{2\rho} \mathbf{P}_n = (\mathbf{n} \cdot \text{grad}) \mathbf{u} + \frac{1}{2} [\mathbf{n} \times \text{curl } \mathbf{u}] - \frac{1}{2} \theta \mathbf{n};$$

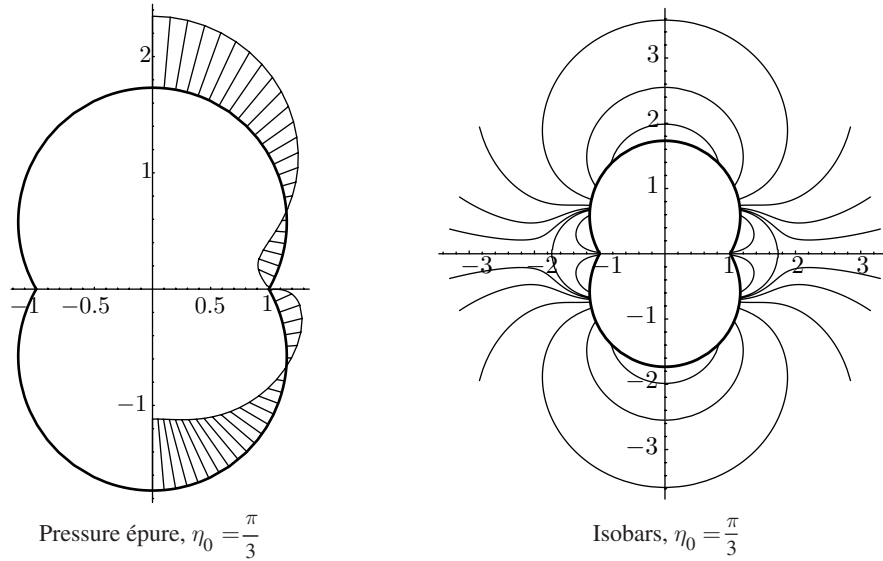

FIG. 6. Épure of the pressure, $\frac{c}{v_0} \theta(\xi, \eta_0)$, at the surface of a rigid biconvex lens-shaped body and isobars for $\eta_0 = \frac{\pi}{3}$

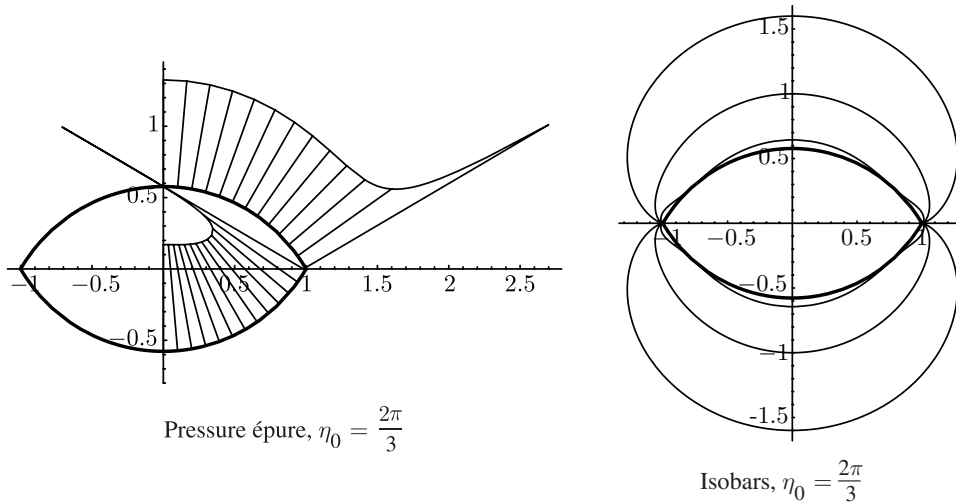

FIG. 7. Épure of the pressure, $\frac{c}{v_0} \theta(\xi, \eta_0)$, at the surface of a rigid biconvex lens-shaped body and isobars for $\eta_0 = \frac{2\pi}{3}$

see [24]. Since the body moves along its axis of symmetry, the resultant force has only the component in the direction \mathbf{k} . Thus, the magnitude of the total drag force is the integral of the projection \mathbf{P}_n onto $(-\mathbf{k})$ over the surface S :

$$\frac{1}{2\rho} F_0 = -\frac{1}{2\rho} \iint_S \mathbf{P}_n \cdot \mathbf{k} \, dS = -\iint_S \left(\left(n_r \frac{\partial}{\partial r} + n_z \frac{\partial}{\partial z} \right) u_z + \frac{1}{2} \omega n_r - \frac{1}{2} \theta n_z \right) dS.$$

To simplify this expression, we use representation (3.5), formula $dS = r d\varphi ds$ and relations

$$\begin{aligned} n_r &= \frac{\partial z}{\partial s}, & n_z &= -\frac{\partial r}{\partial s}, \\ \frac{\partial}{\partial s} &= \frac{1}{h} \frac{\partial}{\partial \xi}, & \frac{\partial}{\partial n} &= -\frac{1}{h} \frac{\partial}{\partial \eta}, \end{aligned}$$

where $ds = h d\xi$ is the element of the contour of the surface S in the meridional cross-section (r, z) -plane, and $h = \frac{c}{\cosh \xi - \cos \eta_0}$ is the Lamé coefficient. The directional derivative $\frac{\partial}{\partial s}$ corresponds to the vector \mathbf{s} , which is orthogonal to \mathbf{n} and oriented toward an increase of coordinate ξ . We have

$$\left(n_r \frac{\partial}{\partial r} + n_z \frac{\partial}{\partial z} \right) u_z = -\omega n_r + \frac{1}{r} \frac{\partial}{\partial s} \left(r \frac{\partial \Psi}{\partial z} \right),$$

and using boundary conditions (3.7), i.e., $\left(\frac{\partial}{\partial z} (r \Psi) \right) \Big|_{\eta=\pm\eta_0} = 0$, we obtain

$$\iint_S \frac{1}{r} \frac{\partial}{\partial s} \left(r \frac{\partial \Psi}{\partial z} \right) dS = 2\pi \int_0^{+\infty} \frac{\partial}{\partial \xi} \left(r \frac{\partial \Psi}{\partial z} \right) \Big|_{\eta=-\eta_0}^{\eta=\eta_0} d\xi \equiv 0.$$

Thus, the expression for the total drag force reduces to

$$\frac{1}{2\rho} F_0 = \frac{1}{2} \iint_S (\omega n_r + \theta n_z) dS. \tag{4.5}$$

Using representations (4.1) and (4.3) for functions ω and θ , respectively, we obtain

$$\begin{aligned} \omega n_r + \theta n_z &= \omega_{\text{sphere}} n_r + \theta_{\text{sphere}} n_z \\ &+ 2r \frac{\partial \Phi_1}{\partial n} + \frac{2}{r} \frac{\partial}{\partial s} (r \Phi_0) + \frac{2}{r} \frac{\partial}{\partial s} (rz \Phi_1) + \Phi_1 n_r + 3\tilde{\theta} n_z. \end{aligned}$$

The surface integral for the term $\omega_{\text{sphere}} n_r + \theta_{\text{sphere}} n_z$ is the constant equal to the magnitude of the drag force for a sphere:

$$\iint_S (\omega_{\text{sphere}} n_r + \theta_{\text{sphere}} n_z) dS = 6\pi V_0 c.$$

Note that the integral contribution of the terms $\frac{1}{r} \frac{\partial}{\partial s} (rz \Phi_1)$ and $\frac{\partial \Phi_0}{\partial s}$ to (4.5) is zero. Indeed,

$$\iint_S \frac{1}{r} \frac{\partial}{\partial s} (rz \Phi_1) dS = 2\pi \int_0^{+\infty} \frac{\partial}{\partial \xi} (rz \Phi_1) \Big|_{\eta=-\eta_0}^{\eta=\eta_0} d\xi = 4\pi \lim_{\xi \rightarrow \infty} (rz \Phi_1) \Big|_{\eta=\eta_0} = 0$$

and

$$\iint_S \frac{1}{r} \frac{\partial}{\partial s} (r \Phi_0) dS = 2\pi \int_0^{+\infty} \frac{\partial}{\partial \xi} (r \Phi_0) \Big|_{\eta=-\eta_0}^{\eta=\eta_0} d\xi = 4\pi \lim_{\xi \rightarrow \infty} (r \Phi_0) \Big|_{\eta=\eta_0} = 0.$$

We may avoid the use of Hilbert formulas for expressing $\tilde{\theta}$. Indeed, representing the generalized Cauchy-Riemann system (0.4) in terms of $\frac{\partial}{\partial s}$ and $\frac{\partial}{\partial n}$:

$$\frac{\partial \tilde{\theta}}{\partial n} = \frac{1}{r} \frac{\partial}{\partial s} (r \Phi_1), \quad \frac{\partial \tilde{\theta}}{\partial s} = -\frac{1}{r} \frac{\partial}{\partial n} (r \Phi_1), \tag{4.6}$$

we obtain

$$\tilde{\theta} n_z = -\frac{1}{2r} \frac{\partial}{\partial s} (r^2 \tilde{\theta}) - \frac{1}{2} \frac{\partial}{\partial n} (r \Phi_1),$$

where the integral contribution of the term $\frac{1}{r} \frac{\partial}{\partial s} (r^2 \tilde{\theta})$ to (4.5) is zero:

$$\iint_S \frac{1}{r} \frac{\partial}{\partial s} (r^2 \tilde{\theta}) dS = 2\pi \int_0^{+\infty} \frac{\partial}{\partial \xi} (r^2 \tilde{\theta}) \Big|_{\eta=-\eta_0}^{\eta=\eta_0} d\xi = 4\pi c^2 \lim_{\xi \rightarrow \infty} \tilde{\theta}(\xi, \eta_0) = 0.$$

Note that $\lim_{\xi \rightarrow \infty} \tilde{\theta}(\xi, \eta_0) = 0$ because of the fact that $\tilde{\theta}$ and Φ_1 are related by (4.6), and $\lim_{\xi \rightarrow \infty} \Phi_1(\xi, \eta_0) = 0$.

Thus, expression (4.5) reduces to

$$\frac{1}{2\rho} F_0 = 3\pi V_0 c - \frac{\pi}{2} \int_0^{+\infty} \left(r^2 \frac{\partial \Phi_1}{\partial \eta} - \Phi_1 r \frac{\partial r}{\partial \eta} \right) \Big|_{\eta=-\eta_0}^{\eta=\eta_0} d\xi. \tag{4.7}$$

Substituting representation (3.15) into (4.7) and using relations

$$\int_0^{+\infty} \frac{\sinh^2 \xi}{(\cosh \xi - \cos \eta)^{\frac{3}{2}}} P_{-\frac{1}{2}+\mu}^{(1)}(\cosh \xi) d\xi = -2\sqrt{2} \left(\mu^2 - \frac{1}{4}\right) \frac{\cos[(\pi - \eta)\mu]}{\mu \sin[\pi\mu]},$$

$$\frac{3}{2} \sin \eta \int_0^{+\infty} \frac{\sinh^2 \xi}{(\cosh \xi - \cos \eta)^{\frac{5}{2}}} P_{-\frac{1}{2}+\mu}^{(1)}(\cosh \xi) d\xi = 2\sqrt{2} \left(\mu^2 - \frac{1}{4}\right) \frac{\sin[(\pi - \eta)\mu]}{\sin[\pi\mu]},$$

we obtain

$$\frac{1}{2\rho} F_0 = 3\pi V_0 c + i\sqrt{2} \int_{-i\infty}^{+i\infty} \left(\mu^2 - \frac{1}{4}\right) B(\mu) d\mu. \tag{4.8}$$

Finally, substituting (3.22) for the function $B(\mu)$ into expression (4.8), we obtain (4.4). □

Figure 8 illustrates the behavior of the normalized drag force $\frac{F_0}{6\pi\rho V_0 c}$ as a function of η_0 . Table 2 presents values of $\frac{F_0}{6\pi\rho V_0 c}$ for $\eta_0 = \frac{\pi k}{12}$, $1 \leq k \leq 12$. The case of $\eta_0 = \pi$ corresponds to a flat disk. In this case, integral (4.4) is calculated analytically, and the exact value of $\frac{F_0}{6\pi\rho V_0 c}$ is $8/(3\pi)$. In the case of $\eta_0 \rightarrow 0$, we have $F_0 \rightarrow \infty$.

The drag force may also be calculated as the limit of the stream function at $z = 0$ and $r \rightarrow \infty$:

$$F_0 = -8\pi\rho \lim_{r \rightarrow \infty} \Psi|_{z=0};$$

see [10]. For the stream function given by (3.12), this expression reduces to (4.8) and, consequently, is equivalent to (4.4).

TABLE 2. Normalized drag force, $\frac{F_0}{6\pi\rho V_0 c}$, as a function of η_0

η_0	$\frac{F_0}{6\pi\rho V_0 c}$	η_0	$\frac{F_0}{6\pi\rho V_0 c}$
$\pi/12$	4.9545	$7\pi/12$	0.9237
$2\pi/12$	2.5167	$8\pi/12$	0.8810
$3\pi/12$	1.7229	$9\pi/12$	0.8599
$4\pi/12$	1.3418	$10\pi/12$	0.8515
$5\pi/12$	1.1278	$11\pi/12$	0.8491
$6\pi/12$	1	$12\pi/12$	0.8488 [†]

[†]The case of $\eta_0 = \pi$ corresponds to a flat disk. In this case, the exact value of $\frac{F_0}{6\pi\rho V_0 c}$ is $8/(3\pi)$.

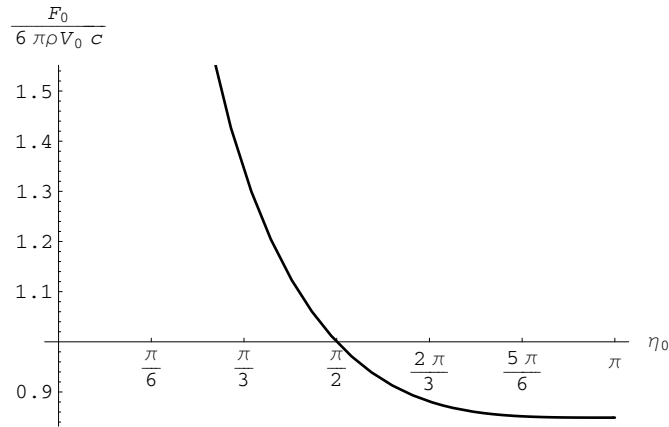
FIG. 8. Normalized drag force, $\frac{F_0}{6\pi\rho V_0 c}$, as a function of η_0

5. Conclusion. We have derived Hilbert formulas for an r -analytic function for the domain, \mathcal{D}_L , exterior to the contour of a biconvex lens in the meridional cross-section plane, and applied these formulas in the 3D problem of axially symmetric steady motion of a rigid biconvex lens-shaped body in a Stokes fluid.

In the domain \mathcal{D}_L , we have reduced the generalized Cauchy-Riemann system (0.4) to the three-contour problem (2.3) for the densities in the Mehler-Fock integrals, representing the real and imaginary parts of an r -analytic function. This problem coincided with the one that we obtained for the corresponding densities in Fourier integrals for the domain external to the contour of a spindle in bi-spherical coordinates [31]. However, in contrast to [31], we have assumed that densities in the Mehler-Fock integrals were meromorphic functions with an arbitrary number of simple poles in the strip $-1 \leq \operatorname{Re} \mu \leq 1$. This assumption was dictated by the hydrodynamic problem of the steady motion of a rigid biconvex lens-shaped body in a viscous fluid: the function $B(\mu)$ in (3.22) has at least two simple poles at $\mu = \pm \frac{1}{2}$ for all values of the parameter η_0 . As a result, we have extended the framework of Riemann boundary-value problems, originally suggested in [31], to solve the three-contour problem (2.3) for $X(\mu)$ and $Y(\mu)$ from the specified class

of meromorphic functions under the additional conditions (2.4). Thanks to these conditions, we showed that the Hilbert formulas coincide with those obtained in [31], when $X(\mu)$ and $Y(\mu)$ are functions meromorphic in $-1 \leq \operatorname{Re} \mu \leq 1$ with only two simple poles at $\mu = \pm \frac{1}{2}$. For numerical calculations, we have represented the Mehler-Fock integrals with the Hilbert formulas in the form of regular integrals.

Using the stream function approach, we have solved the 3D problem of the steady motion of a rigid biconvex lens in a Stokes fluid. The suggested stream function (3.12) includes the term, associated with the stream function for a sphere, to provide proper representations of boundary conditions in the form of Mehler-Fock integrals. Based on the fact that $F = \theta + i r \omega$ is the r -analytic function, we have applied the Hilbert formula for the real part to express the pressure in the fluid about the body via the vortex function. As an illustration to the obtained result, we have calculated isobars about the body, épures of the pressure at the contour of the body and the drag force exerted on the body by the fluid.

Acknowledgements. We are grateful to the anonymous referees for their valuable comments and suggestions, which greatly helped to improve the quality of the paper.

Appendix A. The proof of Proposition 2.2. First, we prove formula (2.21). Substituting formula (2.8) into (1.4), we obtain

$$\omega(\xi, \eta) = \frac{1}{2\pi i} \sqrt{\cosh \xi - \cos \eta} \int_{-\infty}^{+\infty} \left(\tau X(i\tau) + \frac{1}{2} \int_{-\infty}^{+\infty} X(i\tau_1) \frac{\cosh[\pi\tau_1]}{\cosh[\pi\tau]} \frac{d\tau_1}{\sinh[\pi(\tau_1 - \tau)]} \right) \times \frac{P_{-\frac{1}{2}+i\tau}^{(1)}(\cosh \xi)}{\tau^2 + \frac{1}{4}} e^{-\eta\tau} d\tau. \tag{A.1}$$

The inner integral in (A.1) is singular, but the external integral is regular. Consequently, we do not need the Poincaré-Bertrand formula for changing the order of integration in (A.1) (see [6]):

$$\begin{aligned} \mathcal{S}_Y(\xi, \eta) &= \frac{1}{2} \int_{-\infty}^{+\infty} \left(\int_{-\infty}^{+\infty} X(i\tau_1) \frac{\cosh[\pi\tau_1]}{\sinh[\pi(\tau_1 - \tau)]} d\tau_1 \right) \frac{P_{-\frac{1}{2}+i\tau}^{(1)}(\cosh \xi)}{(\tau^2 + \frac{1}{4}) \cosh[\pi\tau]} e^{-\eta\tau} d\tau \\ &= \frac{1}{2} \int_{-\infty}^{+\infty} X(i\tau_1) \cosh[\pi\tau_1] \underbrace{\left(\int_{-\infty}^{+\infty} \frac{P_{-\frac{1}{2}+i\tau}^{(1)}(\cosh \xi)}{(\tau^2 + \frac{1}{4}) \cosh[\pi\tau]} \frac{e^{-\eta\tau} d\tau}{\sinh[\pi(\tau_1 - \tau)]} \right)}_{I_1(\xi, \eta, \tau_1)} d\tau_1. \end{aligned}$$

The inner integral $I_1(\xi, \eta, \tau_1)$ in $\mathcal{S}_Y(\xi, \eta)$ is calculated based on the following representation [1]:

$$P_{-\frac{1}{2}+i\tau}^{(1)}(\cosh \xi) = -\frac{2\sqrt{2}}{\pi} \frac{(\tau^2 + \frac{1}{4})}{\sinh \xi} \int_0^\xi \cos[\tau t] \sqrt{\cosh \xi - \cosh t} dt.$$

We obtain

$$\begin{aligned} I_1(\xi, \eta, \tau_1) &= -\frac{2\sqrt{2}}{\pi \sinh \xi} \int_0^\xi J_1(\eta, \tau_1, t) \sqrt{\cosh \xi - \cosh t} dt \\ &= -\frac{2\sqrt{2}}{\pi \sinh \xi} \frac{1}{\cosh[\pi \tau_1]} \left(e^{-\eta \tau_1} \int_0^\xi g(\eta, \tau_1, t) \sqrt{\cosh \xi - \cosh t} dt \right. \\ &\quad \left. + 2 h_1(\xi, \eta) \sin \frac{\eta}{2} \right), \quad \eta \neq 0, \end{aligned}$$

where

$$\begin{aligned} J_1(\eta, \tau_1, t) &= \int_{-\infty}^{+\infty} \frac{\cos[\tau t]}{\cosh[\pi \tau]} \frac{e^{-\eta \tau} d\tau}{\sinh[\pi(\tau_1 - \tau)]} \\ &= \frac{1}{\cosh[\pi \tau_1]} \left(g(\eta, \tau_1, t) e^{-\eta \tau_1} + \frac{2 \sin \frac{\eta}{2} \cosh \frac{t}{2}}{\cosh t - \cos \eta} \right), \end{aligned} \quad (\text{A.2})$$

$$h_1(\xi, \eta) = \int_0^\xi \frac{\sqrt{\cosh \xi - \cosh t}}{\cosh t - \cos \eta} \cosh \frac{t}{2} dt = \frac{\pi}{\sqrt{2}} \left[\sqrt{1 + \frac{\sinh^2 \frac{\xi}{2}}{\sin^2 \frac{\eta}{2}}} - 1 \right], \quad \eta \neq 0,$$

and the function $g(\eta, \tau_1, t)$ is determined by (2.23). For $\eta = 0$, expression (A.2) takes on finite values for all $t \in [0, \xi]$:

$$J_1(0, \tau_1, t) = \frac{\sin[\tau_1 t]}{\cosh[\pi \tau_1]} \coth \frac{t}{2}. \quad (\text{A.3})$$

Thus,

$$I_1(\xi, 0, \tau_1) = -\frac{2\sqrt{2}}{\pi \sinh \xi} \int_0^\xi J_1(0, \tau_1, t) \sqrt{\cosh \xi - \cosh t} dt,$$

and $G_1(\xi, \eta, \tau_1) = \frac{1}{2} I_1(\xi, \eta, \tau_1) \cosh[\pi \tau_1]$.

Formula (2.21) is proved similarly. Substituting formula (2.7) into (1.3), we obtain

$$\begin{aligned} \theta(\xi, \eta) &= \frac{1}{2\pi} \sqrt{\cosh \xi - \cos \eta} \int_{-\infty}^{+\infty} \left(\tau Y(i\tau) - \frac{1}{2} \int_{-\infty}^{+\infty} Y(i\tau_1) \frac{\cosh[\pi \tau_1]}{\cosh[\pi \tau]} \frac{d\tau_1}{\sinh[\pi(\tau_1 - \tau)]} \right) \\ &\quad \times P_{-\frac{1}{2}+i\tau}(\cosh \xi) e^{-\eta \tau} d\tau. \end{aligned} \quad (\text{A.4})$$

Although the inner integral in (A.4) is singular, the external integral is regular. Consequently, we do not need the Poincaré-Bertrand formula for changing the order of integration in (A.4) (see [6]):

$$\begin{aligned} \mathcal{S}_X(\xi, \eta) &= \int_{-\infty}^{+\infty} \left(\int_{-\infty}^{+\infty} Y(i\tau_1) \frac{\cosh[\pi\tau_1] d\tau_1}{\sinh[\pi(\tau_1 - \tau)]} \right) \frac{P_{-\frac{1}{2}+i\tau}(\cosh \xi)}{\cosh[\pi\tau]} e^{-\eta\tau} d\tau \\ &= \int_{-\infty}^{+\infty} Y(i\tau_1) \cosh[\pi\tau_1] \underbrace{\left(\int_{-\infty}^{+\infty} \frac{P_{-\frac{1}{2}+i\tau}(\cosh \xi)}{\cosh[\pi\tau]} \frac{e^{-\eta\tau} d\tau}{\sinh[\pi(\tau_1 - \tau)]} \right)}_{I_2(\xi, \eta, \tau_1)} d\tau_1. \end{aligned}$$

The inner integral $I_2(\xi, \eta, \tau_1)$ in $\mathcal{S}_X(\xi, \eta)$ is calculated based on the following representation [1]:

$$P_{-\frac{1}{2}+i\tau}(\cosh \xi) = \frac{4\sqrt{2}}{\pi \sinh^2 \xi} \int_0^\xi \cos[\tau t] \left(\cosh \xi - \frac{1}{3} \left(\tau^2 + \frac{9}{4} \right) (\cosh \xi - \cosh t) \right) \times \sqrt{\cosh \xi - \cosh t} dt.$$

We have

$$I_2(\xi, \eta, \tau_1) = \frac{4\sqrt{2}}{\pi \sinh^2 \xi} \int_0^\xi \left(J_1(\eta, \tau_1, t) \cosh \xi \sqrt{\cosh \xi - \cosh t} - \frac{1}{3} J_2(\eta, \tau_1, t) (\cosh \xi - \cosh t)^{\frac{3}{2}} \right) dt,$$

where the function $J_1(\eta, \tau_1, t)$ is defined by (A.2), and

$$J_2(\eta, \tau_1, t) = \int_{-\infty}^{+\infty} \frac{\cos[\tau t]}{\cosh[\pi\tau]} \frac{(\tau^2 + \frac{9}{4}) e^{-\eta\tau} d\tau}{\sinh[\pi(\tau_1 - \tau)]} = \frac{9}{4} J_1(\eta, \tau_1, t) + \frac{\partial^2}{\partial \eta^2} J_1(\eta, \tau_1, t).$$

Using intermediate calculations,

$$\begin{aligned} h_2(\xi, \eta) &= \int_0^\xi \frac{(\cosh \xi - \cosh t)^{\frac{3}{2}}}{\cosh t - \cos \eta} \cosh \frac{t}{2} dt \\ &= (\cosh \xi - \cos \eta) h_1(\xi, \eta) - \frac{\pi}{\sqrt{2}} \sinh^2 \frac{\xi}{2}, \quad \eta \neq 0, \end{aligned}$$

$$\sin \frac{\eta}{2} \left(2h_1(\xi, \eta) \cosh \xi - \frac{3}{2} h_2(\xi, \eta) \right) - \frac{2}{3} \frac{\partial^2}{\partial \eta^2} \left(h_2(\xi, \eta) \sin \frac{\eta}{2} \right) = \frac{\pi}{4} \frac{\sinh^2 \xi \operatorname{sign} \eta}{\sqrt{\cosh \xi - \cos \eta}}, \quad \eta \neq 0,$$

where the function $h_1(\xi, \eta)$ is defined by (2.24), we reduce the integral $I_2(\xi, \eta, \tau_1)$ to the form:

$$I_2(\xi, \eta, \tau_1) = \frac{1}{\cosh[\pi\tau_1]} \left(R(\xi, \eta, \tau_1, t) e^{-\eta\tau_1} + \frac{\sqrt{2} \operatorname{sign} \eta}{\sqrt{\cosh \xi - \cos \eta}} \right), \quad \eta \neq 0,$$

where

$$R(\xi, \eta, \tau_1, t) e^{-\eta\tau_1} = \frac{4\sqrt{2}}{\pi \sinh^2 \xi} \int_0^\xi \left[g(\eta, \tau_1, t) e^{-\eta\tau_1} \left(\frac{3}{4} \cosh t + \frac{1}{4} \cosh \xi \right) \sqrt{\cosh \xi - \cosh t} \right. \\ \left. - \frac{1}{3} \frac{\partial^2}{\partial \eta^2} (g(\eta, \tau_1, t) e^{-\eta\tau_1}) (\cosh \xi - \cosh t)^{\frac{3}{2}} \right] dt,$$

and the function $g(\eta, \tau_1, t)$ is defined by (2.23). In the case of $\eta = 0$, we use (A.3) and the relation

$$J_2(0, \tau_1, t) = \frac{9}{4} J_1(0, \tau_1, t) - \frac{\partial^2}{\partial t^2} J_1(0, \tau_1, t)$$

to derive an expression for $I_2(\xi, 0, \tau_1)$:

$$I_2(\xi, 0, \tau_1) = \frac{1}{\cosh[\pi\tau_1]} \frac{4\sqrt{2}}{\pi \sinh^2 \xi} \int_0^\xi \left(\coth \frac{t}{2} \sin[\tau_1 t] \left(\frac{3}{4} \cosh t + \frac{1}{4} \cosh \xi - \frac{1}{2} \right) \right. \\ \left. + \tau_1 \cosh^2 \frac{t}{2} \cos[\tau_1 t] \right) \sqrt{\cosh \xi - \cosh t} dt.$$

Note that the integrand in $I_2(\xi, 0, \tau_1)$ takes on finite values for all $t \in [0, \xi]$. Finally, defining $G_2(\xi, \eta, \tau_1) = \frac{1}{2} I_2(\xi, \eta, \tau_1) \cosh[\pi\tau_1]$, we finish the proof of the proposition.

REFERENCES

- [1] Bateman, H., Erdelyi, A. (1953). *Higher Transcendental Functions*. Vol. 1, McGraw-Hill Book Company, Inc., New York, 396 pp. MR0058756 (15:419i)
- [2] Beltrami E. (1911) *Sulle Funzioni Potenziali di Sistemi Simmetrici Intorno ad un Asse*. Opere Matematiche, Vol. 3, pp. 115–128.
- [3] Bers, L. (1953). *Theory of Pseudo-analytic Functions*. Institute for Mathematics and Mechanics, New York University, 187 pp. MR0057347 (15:211c)
- [4] Bers L. and Gelbart A. (1943) *On a Class of Differential Equations in Mechanics of Continua*. Quarterly of Applied Mathematics, Vol. 1, pp. 168–188. MR0008556 (5:25b)
- [5] Collins, W.D. (1963). *A Note on the Axisymmetric Stokes Flow of Viscous Fluid Past a Spherical Cap*. Mathematika, Vol. 10, pp. 72–78. MR0154496 (27:4442)
- [6] Gakhov, F.D. (1966). *Boundary Value Problems*. Pergamon Press, Oxford, New York, 561 pp. MR0198152 (33:6311)
- [7] Ghosh, S. (1927). *On the Steady Motion of a Viscous Liquid due to Translation of a Torus Parallel to its Axis*. Bulletin of the Calcutta Mathematical Society, Vol. 18, pp. 185–194.
- [8] Goman, O.G. (1984). *Representation in Terms of p -Analytic Functions of the General Solution of Equations of the Theory of Elasticity of a Transversely Isotropic Body*. Journal of Applied Mathematics and Mechanics, Vol. 48, Issue 1, pp. 62–67. MR0792756 (86j:73024)
- [9] Goren, S.L., O'Neill, M.E. (1980). *Asymmetric Creeping Motion of an Open Torus*. Journal of Fluid Mechanics, Vol. 101, Part 1, pp. 97–110.
- [10] Happel, J., Brenner, H. (1983). *Low Reynolds Number Hydrodynamics*. Springer, New York, 572 pp.
- [11] Hill, R., Power, G. (1956). *Extremum Principles for Slow Viscous Flow and the Approximate Calculation of Drag*. The Quarterly Journal of Mechanics and Applied Mathematics, Vol. 9, Part 3, pp. 313–319. MR0081109 (18:354c)
- [12] Hobson, E.W. (1955) *The Theory of Spherical and Ellipsoidal Harmonics*. Chelsea Publishing Co., New York. MR0064922 (16:356i)
- [13] Johnson, R.E., Wu, T.Y. (1979). *Hydrodynamics of Low-Reynolds-number Flow. Part 5. Motion of a Slender Torus*. Journal of Fluid Mechanics, Vol. 95, Part 2, pp. 263–277.
- [14] Lamb, H. (1945). *Hydrodynamics*. 6th edition, Dover Publications, New York, 738 pp. MR1317348 (96f:76001)
- [15] Payne, L.E. (1952). *On Axially Symmetric Flow and the Method of Generalized Electrostatics*. Quarterly of Applied Mathematics, No. 10, pp. 197–204. MR0051060 (14:422b)

- [16] Payne, L.E., Pell, W.H. (1960). *The Stokes Flow Problem for a Class of Axially Symmetric Bodies*. J. Fluid Mechanics, Vol. 7, pp. 529–549. MR0115471 (22:6272)
- [17] Pell, W.H., Payne, L.E. (1960). *The Stokes Flow about a Spindle*. Quarterly of Applied Mathematics, Vol. 18, No. 3, pp. 257–262. MR0120967 (22:11715)
- [18] Pell, W.H., Payne, L.E. (1960). *On Stokes Flow about a Torus*. Mathematika, Vol. 7, pp. 78–92. MR0143413 (26:969)
- [19] Polozhii, G.M. (1973). *Theory and Application of p -Analytic and (p, q) -Analytic Functions*. 2nd edition, Naukova Dumka, Kiev, 423 pp. (in Russian). MR0352489 (50:4976)
- [20] Sneddon, I.N. (1972). *The Use of Integral Transforms*. McGraw-Hill, 539 pp.
- [21] Stimson, M., Jeffery, G.B. (1926). *The Motion of Two-spheres in a Viscous Fluid*. Proceedings of Royal Society, London, A, Vol. 111, pp. 110–116.
- [22] Stokes, G.G. (1880). *Mathematical and Physical Papers*. Vol. I, Cambridge University Press, 328 pp.
- [23] Takagi, H. (1973). *Slow Viscous Flow due to the Motion of a Closed Torus*. Journal of Physical Society of Japan, Vol. 35, No. 4, pp. 1225–1227.
- [24] Ulitko, A.F. (2002). *Vectorial Decompositions in the Three-Dimensional Theory of Elasticity*. Akadempriodika, Kiev, 342 pp. (in Russian)
- [25] Vekua, I.N. (1962). *Generalized Analytic Functions*. Oxford, Pergamon Press, 668 pp. MR0150320 (27:321)
- [26] Vladimirov, V.S. (1971). *Equations of Mathematical Physics*. Marcel Dekker Inc., New York, 418 pp. MR0268497 (42:3394)
- [27] Wakiya, S. (1980). *Axisymmetric Stokes Flow about a Body Made of Intersection of Two Spherical Surfaces*. Archiwum Mechaniki Stosowanej, Vol. 32, No. 5, pp. 809–817.
- [28] Wakiya, S. (1976). *Axisymmetric Flow of a Viscous Fluid near the Vertex of a Body*. Fluid Mechanics, Vol. 78, Part 4, pp. 737–747.
- [29] Wakiya, S. (1974). *On the Exact Solution of the Stokes Equations for a Torus*. Journal of Physical Society of Japan, Vol. 37, No. 3, pp. 780–783.
- [30] Wakiya, S. (1967). *Slow Motion of a Viscous Fluid around Two Spheres*. Journal of Physical Society of Japan, Vol. 22, No. 4, pp. 1101–1109.
- [31] Zabaranin M., Ulitko A.F. (2006). *Hilbert Formulas for r -Analytic Functions in the Domain Exterior to Spindle*. SIAM Journal on Applied Mathematics, Vol. 66, No. 4, pp. 1270–1300.
- [32] Zabaranin, M. (1999). *Exact Solutions to Displacement Boundary-value Problems for an Elastic Medium with a Spindle-shaped Inclusion*. Ph.D. Thesis, National Taras Shevchenko University of Kiev, Kiev, 180 pp. (in Russian).
- [33] Zabaranin, M. (1999). *A Unified Approach to Solving the Generalized Cauchy-Riemann System*. Reports of National Academy of Sciences of Ukraine, No. 5, pp. 30–33 (in Russian). MR1727563 (2000h:30059)
- [34] Zabaranin, M., Ulitko, A.F. (1999). *The Stokes Flow about a Spindle in Axisymmetric Case*. Bulletin of National Taras Shevchenko University of Kiev in the field of Mathematics and Mechanics, Issue 3, pp. 58–66 (in Ukrainian).