

 Open access • Proceedings Article • DOI:10.1117/12.316773

Hobby-Eberly Telescope low-resolution spectrograph — Source link

Gary J. Hill, Harald Nicklas, Phillip J. MacQueen, Carlos Tejada ...+2 more authors

Institutions: University of Texas at Austin, University of Göttingen, Ludwig Maximilian University of Munich

Published on: 09 Jul 1998 - Astronomical Telescopes and Instrumentation (International Society for Optics and Photonics)

Topics: Hobby–Eberly Telescope, Spectrograph, First light, Grism and Telescope

Related papers:

- [The early performance and present status of the Hobby-Eberly telescope](#)
- [Maps of Dust Infrared Emission for Use in Estimation of Reddening and Cosmic Microwave Background Radiation Foregrounds](#)
- [Maps of Dust IR Emission for Use in Estimation of Reddening and CMBR Foregrounds](#)
- [The Sloan Digital Sky Survey: Technical summary](#)
- [The NRAO VLA Sky Survey](#)

Share this paper:    

View more about this paper here: <https://typeset.io/papers/hobby-eberly-telescope-low-resolution-spectrograph-1ksbflb98p>

The Hobby-Eberly Telescope Low Resolution Spectrograph: optical design

F. J. Cobos D.^{a*}, C. Tejada de V.^a, G. J. Hill^b, F. Pérez G.^a.

^aInstituto de Astronomía de la Universidad Nacional Autónoma de México, Apdo. Postal 70-264, 04510 México.

^bMcDonald Observatory, University of Texas at Austin, RLM 15.308, Austin, TX 78712, USA.

ABSTRACT

The Hobby Eberly Telescope (HET[#]) is a revolutionary large telescope of 9.2 meter aperture, which is currently undergoing commissioning at McDonald Observatory. First light was obtained on December 11, 1996. Scientific operations are expected in 1998. The Low Resolution Spectrograph (LRS, a collaboration between the University of Texas at Austin, the Instituto de Astronomía de la Universidad Nacional Autónoma de México, Stanford University, Ludwig-Maximilians-Universität, Munich and Georg-August-Universität, Göttingen) is a high throughput, imaging spectrograph which rides on the HET tracker at prime focus. The LRS will be the first HET facility instrument. The unique nature of the HET has led to interesting optical design solutions for the LRS, aimed at high performance and simplicity. The LRS is a grism spectrograph with a refractive collimator and a catadioptric $f/1.4$ camera. The beam size is 140 mm, resulting in resolving powers between $\lambda/\Delta\lambda \sim 600$ and 3000 with a 1 arcsec wide slit. The LRS optics were designed and partially fabricated at the IAUNAM. We present a description of the LRS specifications and optical design, and describe the manufacturing process.

Keywords: Instrumentation: astronomical spectrographs: optical design.

1. INTRODUCTION

In the autumn of 1995, Larry Ramsey and Gary Hill, HET and HET LRS Project Scientists, visited the Instituto de Astronomía de la Universidad Nacional Autónoma de México (IAUNAM), in order to explore the possibility of a collaboration with the HET instrumentation teams. The involvement of the IAUNAM in the optical design of the collimator and camera for the LRS was a result of that visit, as well as the construction of the major part of the optical elements and the optical set-up of the whole instrument. Prior experience at IAUNAM in the design and construction of astronomical instruments with focal reducers, and the existence of optical and mechanical design groups as well as shop and testing facilities, allowed IAUNAM to take on this significant collaboration. The optics were designed and partially fabricated at IAUNAM, while the mechanical design and fabrication, and the electronics were done by the German partners. The CCD system, camera and software are the Texas contribution to the project.

In the main paper¹ we establish the scientific goals of the project and how the optical specifications are connected with them. A companion paper² discusses details of the mechanical design, and the reader is referred to these papers for an overview of the instrument and details of how the optics are mounted.

The HET mirrors are silver coated, so the throughput of the telescope (after 6 reflections to reach the LRS slit) drops rapidly below $\lambda \sim 400$ nm. This number of reflections is caused by the spherical segmented primary mirror and a 4 mirror corrector, which mainly compensates the large spherical aberration of the primary. A fold-mirror directs light to the LRS. The HET corrector consists of two ellipsoid and two hyperbolic mirrors, with pronounced conical departures from spheres, and one of the hyperbolic surfaces also has aspheric deformation coefficients³. This system is very sensitive to decentering and tilting of the corrector mirrors, the relative positions between them, and the distance between the corrector and the primary.

* Send correspondence to F.J.C.D. or G.J.H.

F.J.C.D.: E-mail: cobos@astrocu.unam.mx; C.T.V.: E-mail: tejada@astrocu.unam.mx; G.J.H.: E-mail: hill@astro.as.utexas.edu.

[#] The HET is a collaboration of five institutions: the University of Texas at Austin, Pennsylvania State University, Stanford University, Ludwig-Maximilians-Universität, Munich and Georg-August-Universität, Göttingen.

2. SPECIFICATIONS

The HET provides a 4-arcmin diameter field of view at $f/4.586$ (4.889 arcsec per mm). We designed the LRS not to degrade a best image, including seeing, of around 1.0-arcsec FWHM. The design problem for the HET is different to that for a similar instrument on other large telescopes, due to the faster focal ratio and the poorer delivered images. Also the location of the LRS at prime focus restricts the envelope for the instrument, and dictates certain design features. Space limitations are severe and require a linear instrument with a refractive collimator and a grism disperser. Grisms are relatively inefficient for groove densities above 600 lines/mm, and the desire to reach a resolution approaching $R=\lambda/\Delta\lambda \sim 1500$ with a 1.0 arcsec wide slit thus results in a beam size around 150 mm. However, this fact also reduces the field angle seen by the collimator, which simplifies the design problem somewhat.

Another favorable consequence of the relatively large pupil size is that we could adopt a single-mirror catadioptric camera design such as a Schmidt with the CCD obscuring part of the center of the beam. The obstruction is acceptable for a 3K x 1K @ 15 μm pixel CCD, which needs an $f/1.4$ camera to image the entire HET field of view and to give the desired spectral coverage.

The varying pupil illumination, as the tracker sweeps over the primary mirror following stars (see Ref. 1, Fig. 1), presents a design problem peculiar to the HET. In most instruments the pupil illumination is constant, but for the HET it is position-, and hence time-variable. As a result the vignetting profile in the field of view, and the energy distribution of the images are time-variable. It will be challenging to calibrate all these effects. A requirement for the LRS results from this: if the images produced by the LRS are small compared to the combined effect of seeing and primary mirror segment mis-alignment, then the variations in the resolution element (both spatially and spectrally) will be minimized. The time variability of the resolution element will provide a limit to the achievable precision for radial velocities, for example. We will calibrate this effect on emission and absorption line objects, and can limit the effect by shortening track times for some programs.

The specific requirements for the LRS optical design were *originally* established as follows :

- Wavelength range : 400 - 1000 nm.
- 0.4 arcsec FWHM, and 80% encircled energy diameter < 0.7 arcsec over one octave, imaging or spectroscopy.
- This image quality maintained over a wavelength coverage in any setting of no less than one octave (a factor of 2 in wavelength).
- Imaging of the 4 arcmin diameter field of view at $f/1.4$ onto the short dimension of the 3K x 1K @ 15 μm pixel CCD. The spectral dispersion is along the long dimension of the CCD.
- High throughput optics using non-absorptive glasses and avoiding exotic materials, if possible.
- All spherical surfaces in collimator, maximum of a single asphere on camera optics.
- Total length of collimator to be kept less than 1000 mm.
- Clearance for slit unit, filter wheel, folding mirror, grisms and CCD cryostat head.
- Focusing using only the rear elements of the collimator.
- Imaging of the slit should not degrade the resolution of the instrument by more than 10% over the field of view.
- 150 mm beam diameter dictated by maximum grism size and space constraints.

Following an initial demonstration of feasibility which exceeded the specifications for spectral coverage and image quality, requirements were added or changed:

- Acceptable image size down to 365 nm wavelength for the whole system, and up to 1400 nm for the collimator .
- Glasses with a potentially large contribution to scattering at short wavelengths should be replaced.
- Images for a 4.54 arcmin field should be corrected following the same criteria.
- Reduction of the beam diameter to 140 mm in order to avoid any possible vignetting by the largest (echelle) grisms.
- CaF_2 was allowed, in order to realize the largest possible wavelength coverage.

3. DESIGN PROCESS

The Zemax-EE optical design program was used for the LRS. The design problem was split into parts, initially, and the camera and collimator were considered separately.

3.1 Collimator

From the point of view of the collimator optical design, the HET optics (spherical primary mirror with its four mirror corrector) was considered part of the optical system, essentially as the supplier of the incoming, partially aberrated, light rays for the LRS.

The starting point for the collimator design was a scaled version of that used in the IAUNAM PUMA instrument,⁴ with a doublet and a triplet. A paraxial lens (the Zemax feature which acts as an ideal thin lens) was used in place of the camera during the initial phase of the design. We desired the doublet and triplet to have similar power (as in the PUMA), so at the start we alternately substituted each with a paraxial lens of the appropriate focal length. At this stage, a number of glass combinations were explored until designs for each multiplet were obtained which individually had relatively low aberrations. At this point the doublet and triplet were combined and then re-optimized individually, holding the other multiplet constant. A refined search for glass substitutions was also made. During the design process, a wider wavelength range and a larger field of view were introduced as temporary requirements, in order to choose between specific glass options. We also experimented with several routes out of the labyrinthine design problem, in order to develop a feel for this particular system. Finally, the design was optimized allowing the doublet and triplet parameters to vary simultaneously. The doublet consists of a SSK2 meniscus bonded with a FK5 biconvex lens. The triplet has a biconvex CaF₂ element sandwiched between K5 and LLF1 meniscus lenses. Of course, as with any complicated design problem, we cannot be certain that we have arrived at the best solution, but this design exceeds the requirements for the LRS and is presented in Fig. 1. Tests show that small axial movements of the triplet are sufficient to focus the instrument for expected variations in the thickness of filters, and expansion of the structure with temperature. Since the doublet and triplet have similar powers, adjustment of the doublet position has an equivalent effect, and we intend to shim its position to adjust focus during setup^{1, 2}. The cells for the multiplets are discussed in ref. 2, and the bonding in ref. 1.

Note that thermal effects (such as the temperature dependence of the refractive indices) were not considered explicitly because it was found that the design is very forgiving of focus changes, which can be compensated with small axial translations of the triplet. The focus range of the triplet was set at +/-2 mm, more than enough to account for all changes expected from expansion of the instrument structure and differences in filter thickness etc.

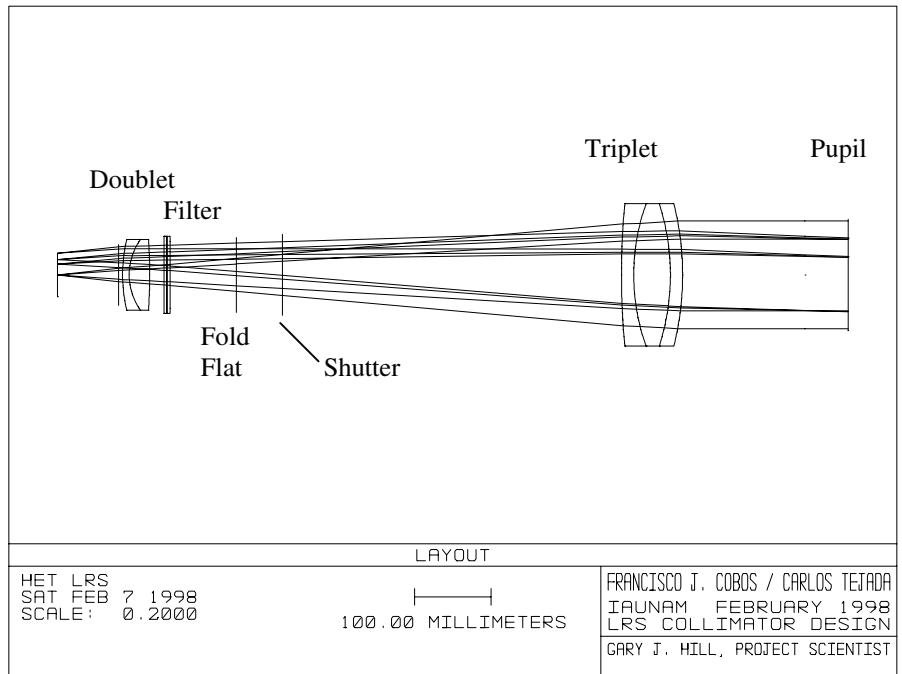

Figure 1. Layout of the LRS collimator

3.2 Camera

Even though the design guidelines for the camera allowed one aspheric element (for example a Schmidt design), we took as the starting point a camera design proposed by S. Cuevas⁵. This design uses all-spherical elements with an air-spaced doublet corrector and a field flattener lens near the detector plane as is presented in Figure 2. It may be characterized as a modified achromatic prime-focus Maksutov design. A similar, but folded, system was designed several years ago for an echelle spectrograph for the UNAM 2 m reflector, but was never constructed. We started by unfolding and scaling one of the best of these previous designs, placing the pupil at an appropriate position. We tried two options: a) the same material for the field flattener and corrector lenses, and b) different materials for these lenses. The possibility of using a doublet field flattener was also explored. Following these investigations, we returned to the original layout, which in the end had proven to be the best solution. All the lenses are fused silica for maximum transmission, and strength, and (particularly for the field flattener) to avoid any chance of radioactivity near the CCD. The CCD will be housed in a small evacuated head with the field flattener lens as the cryostat window, so we did not have to consider the effects of a pressure differential on the shapes of the corrector lenses (as would have been the case with a fully evacuated camera design)².

In designing the camera, light was considered as coming from infinity and the pupil was set at the desired distance from the first corrector lens, with the same diameter as the one provided by the collimator. Then the camera was optimized. It was not reoptimized with the full HET-plus-collimator design because the camera produces significantly better images than those supplied by the HET to the LRS.

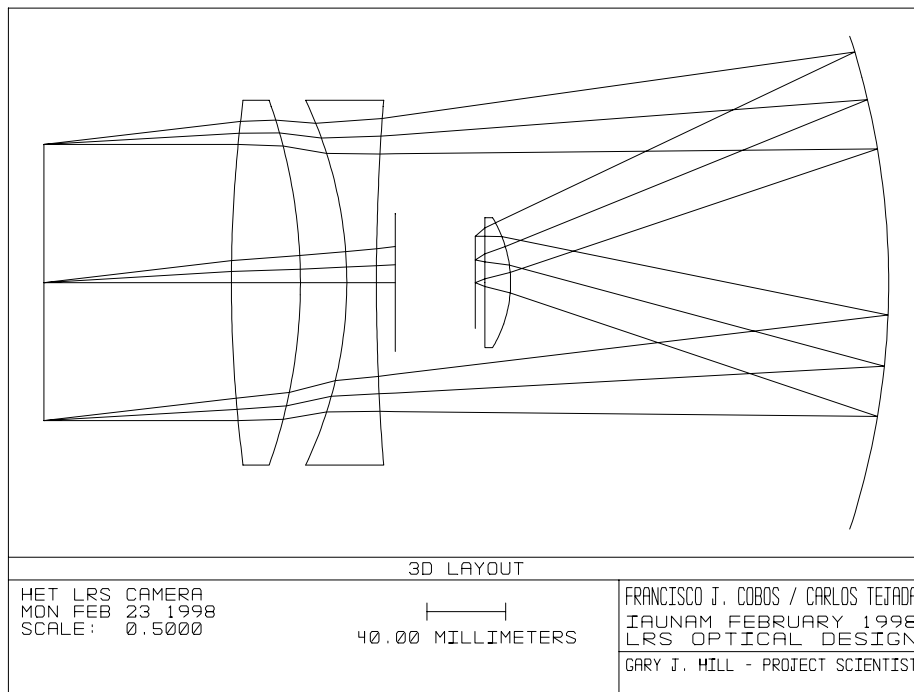

Figure 2. Layout of the LRS camera

4. DESIGN EVALUATION

The distance from the HET focal plane to the last optical surface of collimator is 819.1 mm, and the clearances for slit unit, filter wheel, folding mirror, grisms and CCD head are satisfied. Also, the high throughput requirement is satisfied by the glass selection, the avoidance of thick elements, and by keeping the number of air-glass interfaces to a minimum. In order to appreciate the image quality of the LRS focal reducer, we show, in Figs. 3 and 4, the polychromatic images at the HET focal plane and at the LRS detector for fields up to 4.54 arcmin. Another way to present the LRS performance is by comparing the encircled energy (EE) distributions at the HET focus and the LRS detector, as shown in Figs. 5 and 6, respectively. Note that the imaging at the edge of the HET field is significantly improved by the LRS optics, resulting in a FWHM = 0.3 and EE(80%) = 0.57-arcsec. at the edge of the 4 arcmin diameter HET science field of view for polychromatic light ($\lambda = 405 - 1060$ nm). This fact led us to expand the field over which the LRS will image to 4.54 arcmin diameter, although fields outside 4 arcmin are part of the area accessed by the HET guide-probes¹.

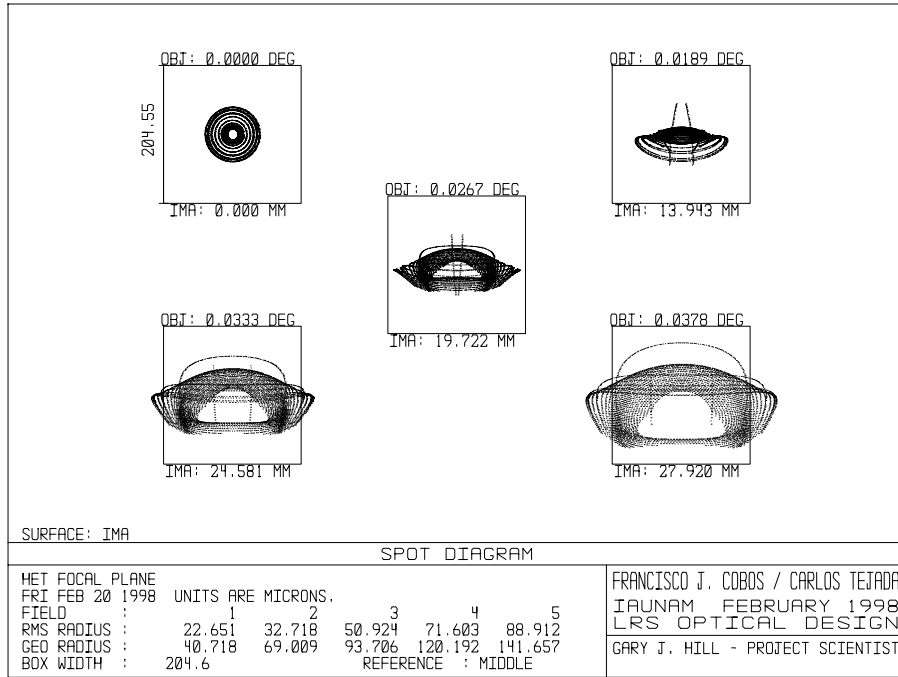

Figure 3. Images at HET Focal Plane (Box side = 1.0 arcsec). Field angles given above boxes correspond to fields of view of 0.0, 2.3, 3.2, 4.0 and 4.54 -arcmin at the HET focus.

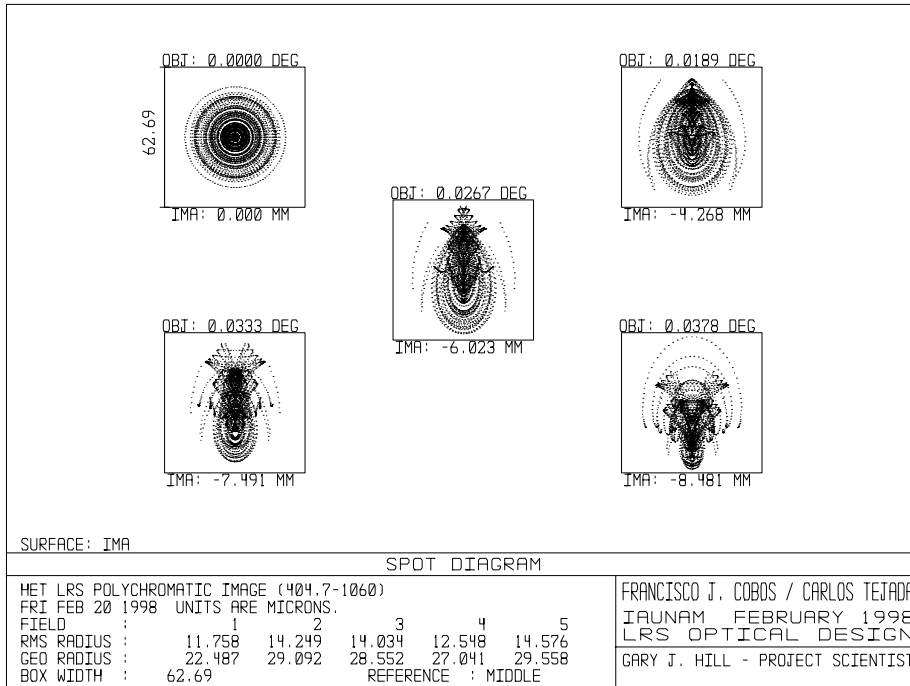

Figure 4. Polychromatic (400-1000 nm) images at LRS detector plane (box side = 1.0 arcsec). Fields as in fig. 3.

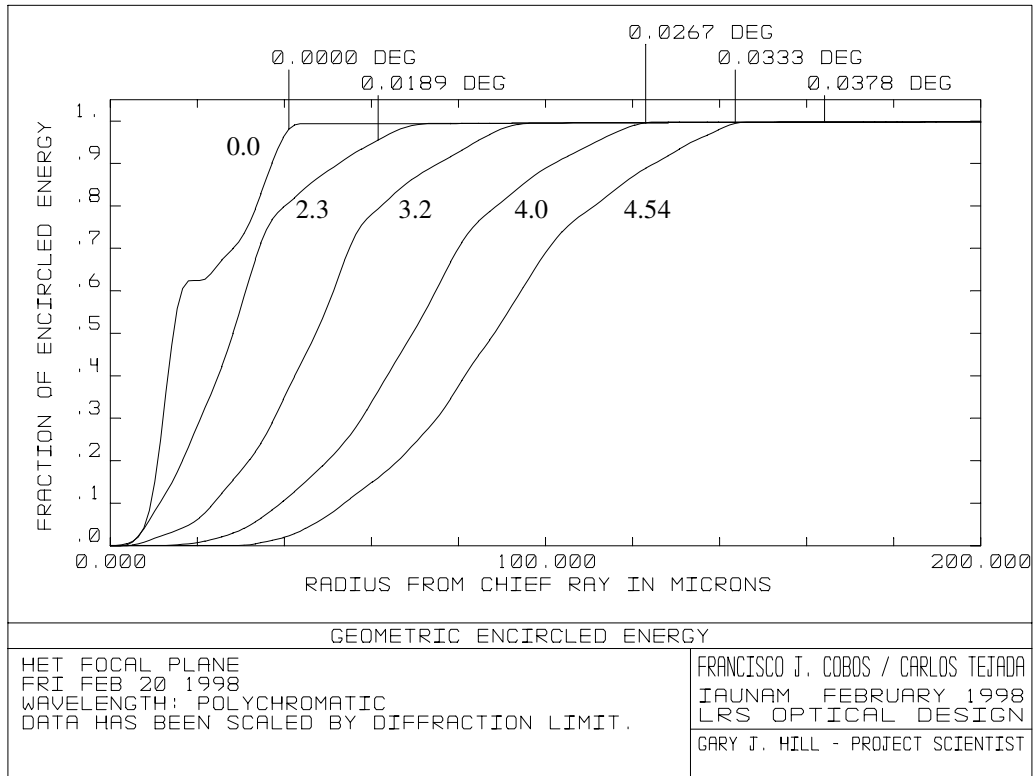

Figure 5. Geometric Energy Distribution at HET focal plane (1.0 arcsec = 204.55 μm). Field in arcmin indicated.

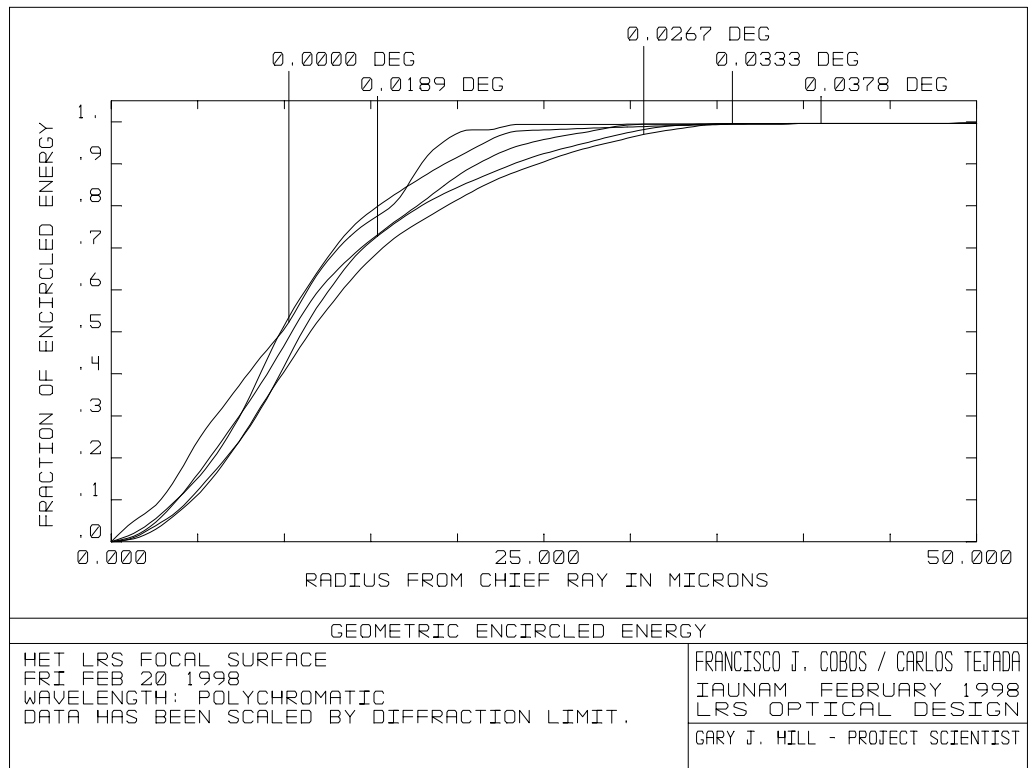

Figure 6. Geometric Energy Distribution at HET LRS focal plane (1.0 arcsec = 62.68 μm)

The LRS optics are correcting aberrations that remain in the HET images, but we must be careful not to significantly degrade the imaging of the LRS slit onto the CCD since the same aberrations are not present within the LRS itself. The polychromatic matrix spot diagram produced just by the LRS with a 600 l/mm grism is shown in Fig. 7. The images cover the entire CCD in the spatial and spectral dimensions (vertical and horizontal in the figure, respectively). See Ref. 1 for details of the grisms. Analysis of the energy distributions in the spectral dimension demonstrates that the image of a 1 arcsec wide slit is not degraded more than 7% over the entire array, meeting the design requirement.

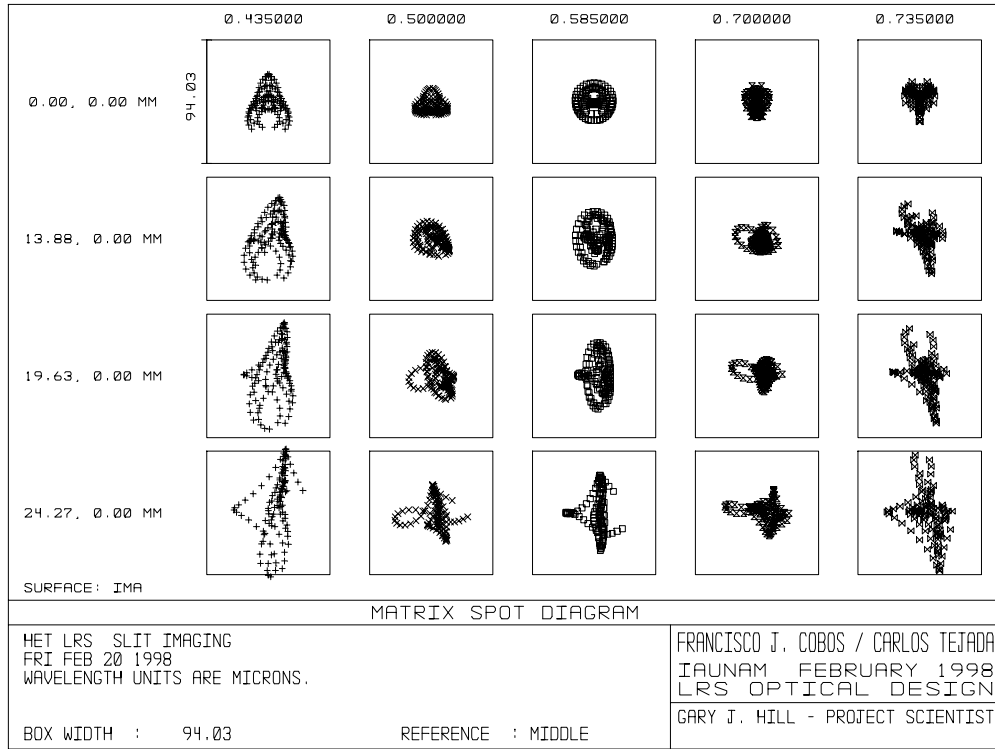

Figure 7. Spot diagrams covering the entire CCD array for the LRS with 600 l/mm grism. Note the box size is 1.5 arcsec. Fields correspond to 0.0, 2.3, 3.2, and 4.0 -arcmin. Wavelengths 0.435, 0.500, 0.585, 0.700, 0.735 μm cover entire CCD with the 600 l/mm grism (Grism 2 see main paper¹).

5. FABRICATION

Astronomical spectrographs are usually designed and constructed as one-off (or prototype) instruments. Ideally there is a great deal of feedback between the various aspects of the design -optics, mechanics, electronics, and software-, and this was the case with the LRS in spite of the dispersed nature of the effort in three countries. In particular the feedback between the optical designer, the optical shop at UNAM and the engineering design in Germany was significant, and improved the final instrument. Specific optical design changes that were made due to new engineering constraints realized during the course of the project included: increasing the space envelope between the slit and the collimator doublet, increasing space for grisms, changes in radii of the CaF₂ element to use existing test plates and reduce cost, and increasing the space between the camera corrector and its focus to ease the design problem of the CCD head.

In normal industry practice, the design, procurement, and fabrication of optics is a linear procedure where tolerances are carefully evaluated and applied to the manufacturing process. Any changes made to the design often result in significant delays and increased costs. The LRS optics were partly fabricated at IAUNAM and partly by companies in the US and Germany (Table 1). In the case of the IAUNAM optical shop, relatively loose tolerances were applied to the surfaces, but they were fabricated one at a time and evaluated once completed. The optical design was then adjusted, allowing the remaining surfaces to be re-optimized to account for any small errors in the ROC of the fabricated surfaces. Alternately, if a surface error was found to impact the design significantly, it was sent back to the shop for further work. This approach avoids very

tight tolerances on individual surfaces, but results in a fairly optimal final product. Elements sent to commercial optical shops were toleranced tightly in the normal way, of course, since feedback was impractical. The LRS optical design is quite forgiving, so this approach worked well in spite of the fact that three optical shops were involved in the manufacture. In particular, the feedback allowed engineering design to proceed in parallel with the optical manufacturing, which saved time and eased the engineering problems. It should be noted that once this philosophy is adopted it should be followed through to the end, otherwise an inferior product may result.

Table 1: Optical Fabrication

IAUNAM, Mexico City, Mexico	Design, collimator doublet, camera lenses.
High Lonesome Optics, Fort Davis, TX, USA	Camera mirror, external elements of triplet.
B. Halle Nachf. GmbH, Berlin, Germany	CaF ₂ element, prisms for grisms.

We were unable to get feedback on the final surfaces fabricated for the HET corrector mirrors, since the LRS development effort turned out to be significantly ahead of the delivery of those mirrors. The LRS corrects residual aberrations in the HET image, but this correction is not large because the image of the slit is not degraded significantly (Fig. 7). The LRS optics will not degrade the HET imaging, and should in fact improve it (Fig. 4).

The concave optical surfaces (either the actual surface or the test plate) were evaluated with an optical bench to measure the ROC, and a Ronchi ruling to test the surface quality. Convex surfaces were evaluated against the test plates with a Fizeau interferometer. Surface qualities of $\lambda/4$ peak-to-peak (p-p) or better were achieved by the IAUNAM shop. Surfaces achieved by High Lonesome Optics are better than this, and the CaF₂ element has $\lambda/2 - \lambda/4$ p-p surfaces. The surface quality of the CaF₂ lens is not critical since it is the internal element of the cemented triplet.

Assembly of the optics and the cells are discussed in the other papers in these proceedings^{1,2}. We expect the instrument to be complete by June 1998.

6. SUMMARY

We have described the optical design procedure for the HET LRS. The optics were designed at IAUNAM and fabricated at IAUNAM, and by companies in Texas and Germany.

The optical design process was an intimate part of the instrument development, with significant feedback between the optical and engineering efforts. Building an instrument with the participation of many institutions and companies in different countries is a very difficult task, due to the complicated communications. We have overcome these obstacles to produce a successful optical design integrated with the engineering requirements as they developed.

The LRS optical design succeeds in surpassing the original specifications, and delivers the following:

- High throughput over 360 - 1000 nm wavelength range.
- Polychromatic (400 - 1000 nm) images which are significantly better than those produced by the HET over the entire 4-arcmin science field: FWHM \sim 0.3 arcsec. and EE(80%) $<$ 0.6 arcsec over the whole field.
- Imaging of the slit which does not degrade the resolution by more than 7% (for a 1.0 arcsec slit) over the entire CCD.
- Resolutions approaching R=1500 in first order, and exceeding R=3000 with the echelle grisms¹.

ACKNOWLEDGMENTS

The authors acknowledge the support provided by Gloria Koenigsberger and Frank Bash, Directors of the Instituto de Astronomía UNAM and the McDonald Observatory of the University of Texas at Austin, respectively. We also thank Mike Marcario of High Lonesome Optics for his help and involvement in the fabrication ; Fernando Garfias who assisted us in the measurement and evaluation of the finished surfaces as quality control ; Salvador Cuevas for the camera design suggestion ; Mike Jones (Lockheed Martin, Dallas) who studied the design, suggested cements, and warned us of the possibility of scattering problems with some glasses; and Harland Epps (UCSC) who advised on bonding the triplet. We also benefitted

from numerous discussions with Phillip MacQueen (UT Austin). Mae Collins, Marco A. Mostalac and Enrique Jiménez provided assistance with (non-trivial) import-export processes.

The LRS has been internally funded by UT Austin, Stanford University, IAUNAM, Universitäts-sternearte Munich (USM) and, Universitäts-sternearte Göttingen (USG), and we are extremely grateful to the following individuals who made the funding a reality, and without whom there would be no LRS: Frank Bash, Greg Shields, and Mary Ann Rankin (UT Austin), Jeff Willick and Roger Romani (Stanford), Gloria Koenigsberger (IAUNAM), Ralf Bender and Rolf Peter Kudritski (USM), and Klaus Fricke and Klaus Beuermann (USG).

REFERENCES

1. G. J. Hill, H. Nicklas, P.J. MacQueen, C. Tejada de V., F. J. Cobos D., and W. Mitsch, "The Hobby-Eberly Telescope Low Resolution Spectrograph", in *Optical Astronomical Instrumentation*, S. D'Odorico, ed., *Proc. SPIE* **3355**, [3355-20], 1998.
2. G. J. Hill, H. Nicklas, P. J. MacQueen, W. Mitsch, W. Wellem, W. Altmann, G. L. Wesley, and F. B. Ray, "The Hobby-Eberly Telescope Low Resolution Spectrograph: mechanical design," in *Optical Astronomical Instrumentation*, *Proc. SPIE* **3355**, paper 74, 1998.
3. L. W. Ramsey, M. T. Adams, T. G. Barnes III, J. A. Booth, M. E. Cornell, N. I. Gaffney, J. W. Glaspey, J. M. Good, J. R. Fowler, P. W. Kelton, V. L. Krabbendam, L. Long, F. B., Ray, R. L. Ricklefs, J. Sage, T. A. Sebring, W. Spiesman, and M. Steiner, "Early performance and present status of the Hobby-Eberly Telescope," in *Advanced Technology Optical/IR Telescopes VI*, *Proc. SPIE* **3352**, paper 06, 1998.
4. R. Langarica, A. Bernal, F. Cobos, M. Rosado, S. Tinoco, F. Garfias, C. Tejada, L. Gutiérrez, F. Angeles; "UNAM scanning Fabry-Perot Interferometer (PUMA) for the study of interstellar medium," in *Instrumentation in Astronomy VIII*, D. L. Crawford, E. R. Craine, eds., *Proc. SPIE* **2198**, pp. 409-412, 1994.
5. S. Cuevas, *Personal communication*.