

KFKI-1980-08

K. RÓZSA

HOLLOW CATHODE DISCHARGES FOR GAS LASERS

Hungarian Academy of Sciences

CENTRAL
RESEARCH
INSTITUTE FOR
PHYSICS

BUDAPEST

2017

KFKI-1980-08

HOLLOW CATHODE DISCHARGES FOR GAS LASERS

Károly Rózsa
Central Research Institute for Physics
H-1525 Budapest 114, P.O.B.49. Hungary

HU ISSN 0368 5330
ISBN 963 371 631 4

ABSTRACT

A review of hollow cathode discharges for gas /metal vapour/ lasers is given. Particular attention is paid to the arc free discharge region and to the possibility of increasing the intensity of the ionic spectrum of the discharges.

АННОТАЦИЯ

Рассмотрены газовые разряды и разряды в парах металлов в лазерах с полым катодом. Особое внимание уделено тёмной части разряда, не содержащей дугу и на возможность увеличения интенсивности ионных спектров.

KIVONAT

Áttekintjük a gáz /fémgőz/ lézerekhez alkalmazott üreges katódu kisüléseket, különös tekintettel az ivmentes kisülési tartományra, és az ionszinkép intenzitásának növelési lehetőségeire.

With the exception of the 632.8 nm neon line all the important visible and ultraviolet cw gas laser lines belong to the spectra of ionized atoms. To achieve proper laser oscillation the excitation of the upper levels of these lines is of primary importance. High energy electrons are needed for this process. As such electrons are in high concentration in the hollow cathode discharge, it was obvious that hollow cathode discharge should be utilized for these lasers. However, to meet laser requirements, there was a need to increase the volume of the discharge and to increase the current density as well as the pressure. Because current became very high the problem of the glow-to-arc transition in such discharges became very serious since arcing not only stops the laser oscillation but may also damage the discharge tube.

The efficiency of these lasers depends on the possibility to excite the ionic spectrum. Excitation can be increased by increasing the high energy part in the electron energy distribution. This "beam" of fast electrons is produced by the cathode fall, so the possibility to increase the voltage of the discharge also became a question of interest.

The present paper deals with the hollow cathode discharge applied to gas /metal vapour/ lasers. First, a brief summary is given of the basic discharge phenomena important to this topic.

The main constructions of different hollow cathode lasers /noble gas mixture, metal vapour, cathode sputtered/ are also surveyed. Detailed measurements on the arc free discharge region and the glow-to-arc transition are presented. These measurements enabled the building of hollow cathode lasers with considerably higher current than was earlier possible.

The question of increasing the voltage is also discussed and different constructions are presented where the voltage is much higher than that of the conventional hollow cathode lasers. We have found increased efficiency and several new laser lines using this type of discharge.

1. BASIC DISCHARGE PHENOMENA FOR HOLLOW CATHODE LASERS

Since a number of excellent books and review articles deal with low pressure glow discharges /see e.g. [1],[2]/ here only those phenomena are mentioned which are of basic importance in constructing hollow cathode lasers.

a./ Abnormal glow discharge.

If we apply direct current through a discharge tube containing two electrodes and low pressure /several torr/ gas the voltage between the electrodes and the discharge near the cathode will depend on the intensity of the current. Here we consider the current from a few milliamps to several amps, and a cold cathode having a sufficiently large /1-100 cm²/ surface. The dependence of the potential between the electrodes on current and also the changing picture of the cathode surface can be seen in Fig.1.

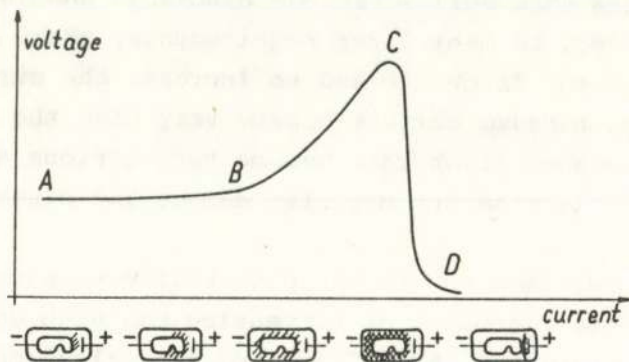

Fig.1

Current voltage characteristic of a cold cathode low pressure discharge in the milliamp.-amp. region. At low current /A-B/ only a part of the cathode is covered by discharge. B-C is the region of the abnormal glow. At high current /D/ the discharge contracts and goes over into an arc.

The discharge tends to run with the lowest possible voltage. The voltage increases with increasing current density. On the other hand, for the longer discharge length along the cathode surface generally little additional voltage is needed provided that the cathode is not too long.

With further increasing current the current density increases as does the voltage until it reaches a maximum. This is the region of the abnormal glow discharge /B-C in Fig.1/.

Still further increase in current causes a contraction of the discharge into a small surface. The voltage also falls to a very small value and the discharge forms an arc /D in Fig.1/. The voltage of the normal discharge is 200-400 V which can be several times this value at its maximum and it then drops below 50 V.

Hollow cathode lasers work in a strongly abnormal discharge and in several cases the laser power continues to increase with increasing current until the glow-to-arc transition.

b./ Cathode dark space and the negative glow.

The cathode region of the glow discharge has essential importance in maintaining the discharge. Different bright and dark layers can be observed here for different gases, pressures and currents. However, here we only consider a more or less dark space next to the cathode surface /cathode dark space/ and a luminous part at the discharge beyond it /negative glow/.

In the conditions of hollow cathode lasers it is mainly these two parts that can be observed. The electric field and the luminosity of the cathode region can be seen in *Fig.2*.

The electric field at the cathode surface is very high /~1000 V/cm/ and decreases with increasing distance from the cathode. This field causes the high voltage drop in the gas at the cathode surface /cathode fall/.

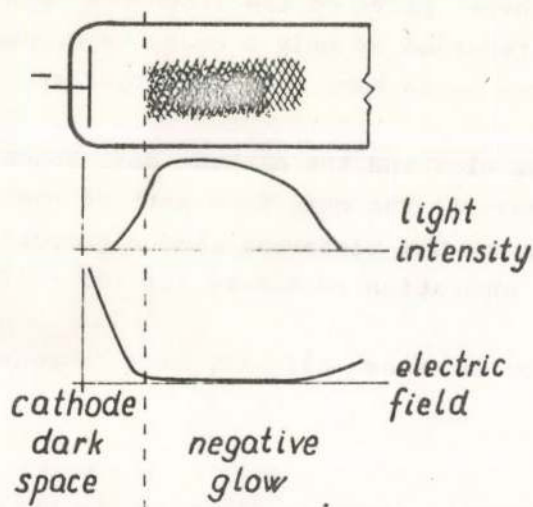

Fig.2

Electric field and light intensity in the cathode dark space and in the negative glow.

Electrons leaving the cathode are released due to the bombardment of the cathode surface by ions, high energy neutral particles and ultraviolet photons. The electrons are accelerated by the high electric field and only after following a certain path do they gain the sufficient energy to excite atoms. Until this region the discharge is dark; the further part of the dark space is only dark compared with the negative glow.

The electrons are accelerated further, they excite and ionize the gas and are multiplied. As the number of electrons increases the discharge gets brighter and forms the negative glow. Here some of the electrons still have high energies. The electron energy distribution in the negative glow has been measured by Pringle and Farvis [3]. They found three different groups of electrons here, viz. fast "primary" electrons, "secondary" electrons of medium energy and concentration, and slow electrons in large concentration.

In the case of hollow cathode lasers however, the pressure and current density are higher. Gill and Webb [4] have recently shown that in the abnormal glow and in pressure of the order of 10 torr, the energy of fast electrons is still much greater than that of corresponding to the Maxwellian distribu-

tion. These fast electrons are responsible for the strong ionic spectrum of the negative glow, and have made it possible to obtain cw oscillations in the spectra of quite a number of ionized atoms in this part of the discharge. A part of the ions /mainly produced in the cathode dark space/ of the ultraviolet photons and high energy neutrals /produced in the cathode region/ hit the cathode surface and release the electrons from the cathode. The condition of a self sustained discharge is that these electrons, through various processes of discharge, should produce the particles necessary to release the required number of electrons. These processes need the volume of the cathode dark space and the negative glow. It is quite easy to establish a self sustained discharge having only these two parts. If the length of the discharge is shorter than that of the cathode dark space and negative glow together we may meet difficulties. The role of the other parts of the discharge /positive column, anode region, etc./ can be regarded as only a means of connecting the negative glow to the anode. These parts have no basic importance in hollow cathode lasers.

The length of both the negative glow and the cathode dark space is inversely proportional to the gas pressure. The mean free path of the electrons increases with decreasing pressure, and the electrons need a proportionately longer path for the excitation and ionization necessary for the self sustained discharge.

The length of the negative glow increases slightly with increasing current.

c./ Hollow cathode discharge.

A very useful tool for spectroscopic investigations is the hollow cathode lamp utilizing the optical properties of the negative glow and further increasing the light intensity by a special cathode geometry. Consider a cold cathode with a hole in it. The diameter of the hole equals the length of the negative glow and twice the length of the cathode dark space.

If we apply current through a discharge tube having such a cathode a very bright discharge is formed within the hollow of the cathode /hollow cathode discharge/. The section of a hollow cathode lamp and the cathode can be seen in Fig.3.

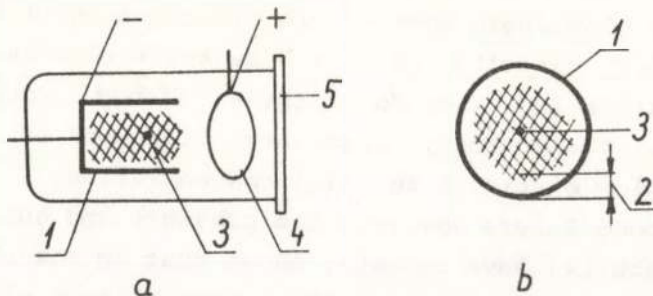

Fig.3

Section of a hollow cathode lamp /a/ and a hollow cathode /b/. 1 cathode, 2. cathode dark space, 3. bright part of the discharge, 4. anode, 5. window.

The negative glow here is concentrated into the centre of the hole. With plane or convex cathodes every part of the cathode surface has its own negative glow, here the negative glow is common, and one glow belongs to the entire cathode surface, even to the opposite surfaces. This discharge is very efficient. Most of the ions and ultraviolet photons, usually lost at the boundary of the negative glow in the case of a plane cathode, can in this case reach the surface of the cathode and release electrons. Thus the voltage of the discharge is lower, or at a given voltage the current is considerably higher than that of a convex cathode. Furthermore, the "beam" of fast electrons is focused into the centre of the discharge thereby increasing the electron density and the intensity of the spectral lines. A part of these electrons travels further towards the opposite cathode surface where they are repelled and thus oscillate further increasing the excitation efficiency in the hollow cathode discharge [5].

Increasing the electron density at low voltage means that the temperature of the hollow cathode discharge remains relatively low and the Doppler broadening of the spectral lines is not so significant.

The dependence of the voltage on gas pressure is shown in Fig.4.

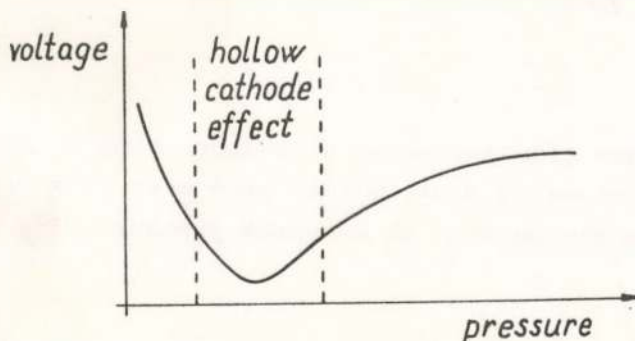

Fig.4

The voltage - pressure characteristic of a hollow cathode discharge at constant current.

At high pressures the length of the cathode dark space and the negative glow is small compared with the diameter of the hole. The negative glow is a bright ring near the cathode surface whereas the centre of the discharge is darker. With decreasing pressure /as the length of the negative glow and dark space increases/ a larger and larger part of the hole is filled with the negative glow, the discharge becomes more efficient and the voltage decreases until a minimum. This is the pressure where the discharge is the brightest in the centre of the hollow /hollow cathode effect/.

The theory of hollow cathode discharge including the radiation from the glow is attributable to Little and von Engel [6]. In Fujii's theory the ion current from the negative glow is also included [7]. Ignition and development of breakdown in hollow cathode discharges have been investigated by Störi, Märk, Varney and Pahl [8]. Electric field distribution and current - voltage

characteristics of a cylindrical hollow cathode discharge have been calculated by Helm, Howorka and Pakl [9].

The intensity distribution of the spectral lines as a function of discharge parameters has been studied in detail by Rózsa [10], Gill [11], Fujii [12] and by Kuen, Störi and Howorka [13].

In Fig.5 the radial intensity distribution can be seen at small and at higher pressure in a 4 mm diameter hollow cathode discharge.

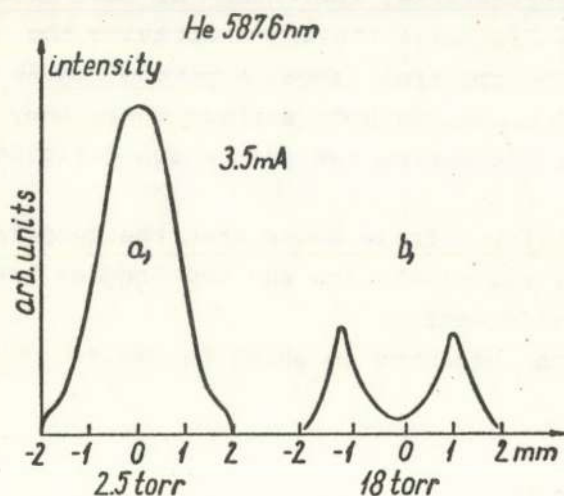

Fig. 5
Radial intensity distribution of the He 587.6 nm line at different pressures.
Hollow cathode diameter is 4 mm.

As the length of the negative glow increases with increasing current we may expect that a Fig.5/b type intensity distribution goes over to a Fig.5/a type distribution if we increase the current at constant pressure /Fig.6/.

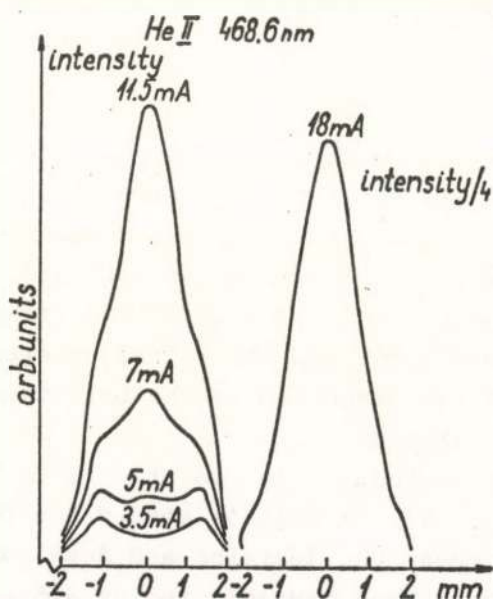

Fig. 6
Current dependence of the radial intensity distribution of the He II 468.6 nm line at constant pressure in hollow cathode discharge.

The Fig.6/b type bright, high pressure and current region is the region of the hollow cathode lasers. A large number of electrons - including high energy electrons - flow into a nearly field free plasma with the help of the cathode fall of a narrow dark space.

The radial distribution of the ion and electron densities has similar dependence on discharge parameters [13]-[15].

In such a discharge the minimum of the voltage corresponding to the hollow cathode effect is not so significant.

In different gases the hollow cathode effect occurs at certain pd values where p is the pressure and d is the diameter of the cathode hollow. Using gases with smaller ionization potential this value of pd is also smaller. If we further decrease the pressure the voltage will increase /see Fig.4/.

The room inside the hollow cathode becomes too small for the self sustained discharge. The number of ionizing collisions decreases and if we still want to produce sufficient ionization in the cathode hollow, higher electron energies - thus higher voltage - are needed.

The smallest pressure where the hollow cathode discharge can be sustained is about 30 % higher than the pressure where the length of the negative glow equals the diameter of the cathode hollow [16].

Apart from being an important light source the hollow cathode discharge proved to be very useful as a continuous source of ions, multiply charged ions and negative ions [17]-[21] as well.

d./ Obstructed discharge

The potential difference between the electrodes depends on the gas pressure and on the distance between the anode and cathode. Figure 7 shows a discharge tube suitable for studying this effect; Fig.8 illustrates the voltage - distance /pressure/ dependence at constant current.

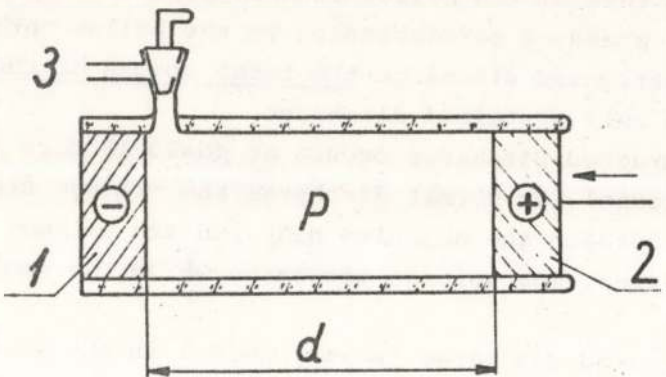

Fig.7

Test tube for studying the voltage - distance dependence of a discharge with plane electrodes.

1. cathode, 2. anode, 3. tube leading to vacuum system. The anode can be moved toward the cathode.

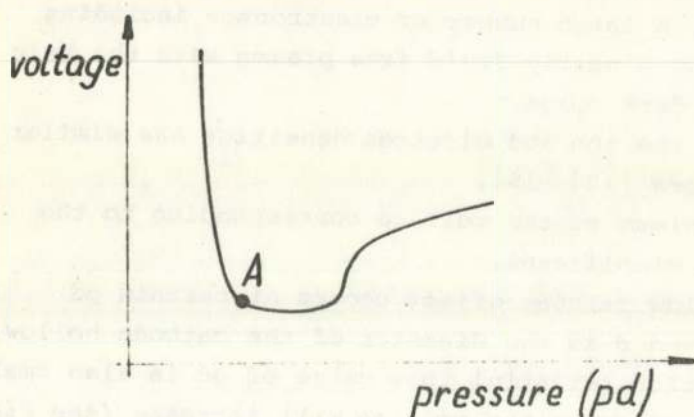

Fig. 8

Dependence of the voltage of the discharge on the distance between the electrodes. At point A the discharge becomes obstructed.

With the electrodes far from each other the discharge has several parts: anode region, positive column, negative glow cathode dark space, etc.

If the anode is moved towards the cathode the voltage decreases and all the parts of the discharge not essential for the self sustained discharge gradually disappear in the anode. At the minimum only the cathode dark space and a part of the negative glow exist. On further decreasing the distance, a steep increase in voltage is caused and the discharge becomes obstructed.

The number of ionizing collisions between electrons and neutral atoms is proportional to the length of the path of the electrons.

When the electrodes are too near each other the necessary number of electron-ion pairs for the self sustained discharge can only be produced at higher voltage as the ionization cross section increases with the energy of electrons accelerated by the electric field in the discharge. At still smaller distances, the discharge stops. The number of ionizing collisions is also proportional to the pressure. Thus the obstructed discharge can also be produced if we keep the distance between the electrodes constant, but decrease the pressure. In *Fig. 8* the abscissa could be scaled in pd units. The phenomenon is similar to that of the hollow cathode discharge operating at a lower pressure than the pressure corresponding to the hollow cathode effect. However, with the obstructed discharge the total volume of the discharge becomes too small for self sustained discharge.

In pure helium the obstructed discharge occurs at $pd=13-15$ Torr mm depending on the cathode material. In normal discharge the voltage starts to increase at the boundary between the negative glow and the cathode dark space. In abnormal glow, however, the voltage increases while the anode is still in the negative glow.

The phenomenon of obstructed discharge is very useful in the construction of hollow cathode lasers. In the strongly abnormal discharge in these lasers the entire surface of the cathode would be covered by discharge. However, discharge is needed only inside the cathode hollow. To protect the

other parts of the cathode against the discharge, it is very convenient to place the anode or an auxiliary anode next to the cathode surface to be protected. The distance between the protected surface and the anode must be smaller than the length of the obstructed discharge at the given pressure.

2. LASERS IN HOLLOW CATHODE DISCHARGE

The interest in hollow cathode lasers has been increasing since the first experiments on hollow cathode He-Cd lasers in 1969-70 [22]-[24]. The number of laser oscillations reported up to now is several hundred; research is still continuing and many types of construction have been attempted in order to find the most suitable one. The active materials used can be divided into four groups according to their vapour characteristics.

- noble gases /Ne, Ar, Kr, Xe/
- metals with low vapour pressure /Cu, Ag, Au, Al, Pb, etc./
- volatile compounds of these metals
- metals with higher vapour pressure /Cd, Zn, Hg, As, etc./

a./ Basic constructions

The constructions of noble gas mixture lasers are the simplest since there is no need to ensure that the vapour pressures are constant along the tube and there is no need to protect the laser windows against the metal vapour.

In the case of low pressure metals cathode sputtering can usefully be used; either the cathode is made of the metal of interest or the inner surface of the cathode is coated with the active metal.

Using more easily evaporable materials, sufficient partial pressure can be ensured by heating, either using separate heating or/and by direct heating of the discharge.

The pressure of the laser material is usually 10^{-1} to 10^{-3} torr, the buffer gas is He or Ne. The great number of different constructions can be divided into two basic groups: lasers with transverse discharge, lasers with /partly/ longitudinal discharge.

Figure 9 shows an example of the transversal discharge hollow cathode laser /after Schuebel [24] /.

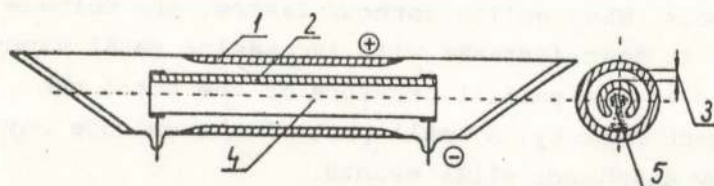

Fig. 9

Hollow cathode laser with transverse discharge.
1. anode, 2. cathode, 3. distance between the two electrodes, 4. place for the hollow cathode discharge, 5. slot.

The discharge is formed between two concentric metal tubes. The outer tube is the anode that can also be used as the wall of the discharge tube. The cathode is situated inside the anode and has a slot along its length. The hollow cathode discharge is formed at the axis of the tube and is connected to the anode through the slot.

These types of lasers are often called "slotted" hollow cathode lasers. If the distance between the anode and the outer surface of the cathode / 3 in Fig.9/ is small enough to give obstructed discharge at the given pressure, the outer surface of the cathode will be protected against the discharge. This problem can also be solved using an internal anode / after Karabut et al. [22]/. In Fig.10 an internal anode transverse discharge hollow cathode laser is shown.

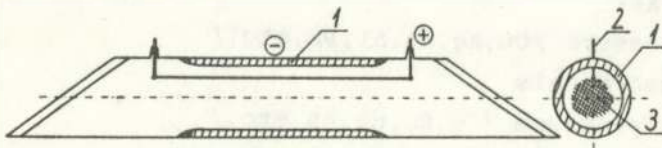

Fig.10

Transverse discharge hollow cathode laser with internal anode.

1. cathode, 2. anode, 3. hollow cathode discharge.

If the anode is placed in the cathode dark space, the whole negative glow can be used for laser oscillation. The cathode can conveniently be cooled or heated to the required temperature.

Lasers like in Fig.9 and 10 where the electrode/s/ forms a part of the wall of the discharge tube have the advantage that there is no need to install electrical connections inside the vacuum tube. Such connections not only make the tube more complicated but may also be a source of undesirable discharge.

The advantage of transversal discharge is that the current is uniform along the tube. If the partial pressures of the components are constant /which is certainly true for noble gas mixture lasers/, both the electron density and the energy distribution will be constant along the length of the discharge since no current is flowing in the longitudinal direction and the current density on the cathode surface is also constant. In any case, the electron density and energy distribution will be a function of the radius. However, using such long electrodes for metal vapour lasers the discharge will not automatically be uniform. Here only the voltage is constant between the two electrodes. With hollow cathode lasers, the voltage hardly depends on current but it does increase with increasing metal vapour density. Small inhomogeneities in the partial pressure of the metal can cause serious changes in current density. A small part of the cathode may even be red hot while the glow discharge still exists.

In several hollow cathode lasers longitudinal /or partly longitudinal/ discharge is used. Such a laser can be seen in Fig.11 /after Sugawara [16]/.

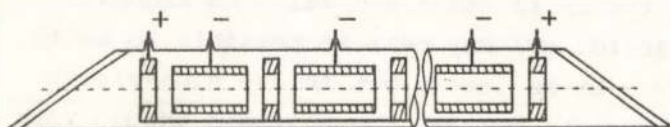

Fig.11
Hollow cathode laser with longitudinal discharge.

Since the cathode segments have independent electrical connection the current of each cathode can be equalized using external resistors.

In such discharges the current density on the cathode surface generally depends on the pressure and current [15], [25], and after a certain cathode length, where relatively high voltage would have been needed for the long path, it obviously decreases. For such reason the length of the cathode is usually not longer than 5-6 times the hollow diameter.

It will be shown in Section 4, however, that a *Fig.11* type discharge proved to be very stable against arcing, which is one of the most serious problems of hollow cathode lasers.

Similar discharge is formed in the "flute type" hollow cathode lasers [26]-[28]. Here a series of holes are drilled in the wall of the cylindrical hollow cathode. The anodes are placed into or above these holes and the discharge current flows from the anodes through these holes into the cathode hollow.

The principles of these lasers can be seen in *Fig.12* /after Piper et al. [26]/.

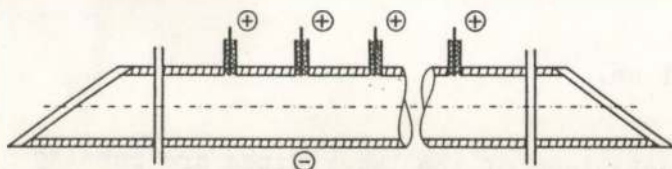

Fig.12
"Flute type" hollow cathode laser.

Such an anode system is often placed in a glass or quartz envelope and the outer surface of the cathode is usually protected by a ceramic or glass insulator.

b./ Noble gas mixture lasers

Results on noble gas mixture hollow cathode lasers using constructions providing high current and high voltage will be discussed in detail in Section 3 and 4.

Laser oscillations have been found in He-Kr, He-Ar and He-Ne-Xe mixtures in the visible region [29]-[34]. It is also possible to obtain cw

oscillation in pure Ar [30]-[35], and on the well known lines in He-Ne [36].

The two strongest lines are the Kr II 469.4 and 431.7 nm lines.

The power of these lasers /10-100 mW/ may make it possible to build simple, medium power lasers, like a He-Ne laser, but in the blue-violet region. As there is no need to evaporate metals, these lasers should work immediately after switching on.

Because of the simplicity of these lasers /parts of the discharge tubes dealing with metal vapour can be omitted/, they are very useful for studying the different laser constructions even if the final goal is to build metal vapour lasers.

The excitation mechanism leading to inverse population in He-Kr, He-Ar, and Ne-Xe lasers is mainly collisions between ground state ions of the lasing gas and the metastable atoms of the buffer gas [29][34] [37]. The ground state ions can be produced both by Penning ionization and by electron impact ionization [38].

c./ Hollow cathode lasers using evaporation.

The first and most popular cw hollow cathode ion lasers belong to this group. Lasers work from the near infrared to the ultraviolet. In this group the He-Cd [16] [22]-[24] [39] [40], He-Zn [11] [16] [22] [40]-[42], He-I [43] [44], He-Hg [45], He-As [46] and Ne-Tl [47] lasers are the most important.

The most characteristic lines are:

Cd II 441.6 nm, 533.8 nm, 537.8 nm,

Zn II 491.2 nm, 492.4 nm, 747.9 nm, 758.8 nm

I II 504.7 nm, 576.1 nm, 612.8 nm, 773.5 nm, 880.4 nm

Hg II 615.0 nm, 794.5 nm,

As II 538.5 nm, 549.7 nm, 651.1 nm,

Tl II 594.9 nm.

The dominant excitation mechanisms of the laser lines are Penning ionization, or charge exchange excitation [11] [16] [40] [48]-[51].

The laser lines excited by charge exchange reactions are usually stronger than the cw laser lines in the noble gas mixture lasers.

Particular attention has to be paid to the metal vapour. The metal vapour pressure should be kept constant along the discharge tube.

If the metal vapour deposits on the wall of the tube it absorbs the gas. Short circuiting can also occur due to the deposited metal. The coldest parts of the discharge tube are usually the Brewster windows and it is essential that they be kept clean since even the smallest amount of metal deposited on the window seriously reduces the laser power.

In the early lasers metal pellets were placed into the cathode or in

the discharge tube and were heated by heating tape and/or by the discharge. It is certainly the simplest method to obtain laser oscillation. However, it is hard to control the metal vapour pressure this way, and the laser power strongly depends on the vapour pressure. A change of 20°C in the temperature of the metal may easily result in 100 % or even more change in laser power.

A possible method of regulating the metal vapour is to place the metal pellets into a side arm and to heat it independently of the discharge. The temperature of the other parts of the tube has to be higher than that of the side arm otherwise the metal vapour deposits on the wall and on the electrodes and the laser cannot be controlled any more.

The Brewster windows cannot usually be kept at the required $100 - 400^{\circ}\text{C}$. Additional positive columns can be used to protect the windows with the help of cataphoresis. The different thermal zones of such a laser can be seen in Fig.13.

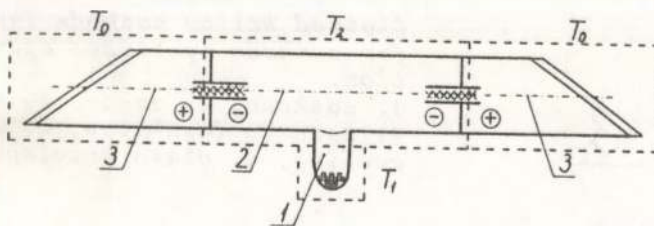

Fig.13

Different thermal zones in a hollow cathode laser.

1. furnace / T_1 , its temperature/
2. place of the hollow cathode discharge / T_2 , its temperature/
3. colder part of the tube where no metal can deposit,
4. protective positive column to keep the metal vapour in part 2.

In such discharges the metal vapour pressure is only a function of T_1 ; small changes in T_2 change the vapour density but this has no serious effect on laser performance.

The cataphoretic transport of metal along hollow cathode discharge was studied by Hattori [52]. If several hollow cathode discharges are switched in series a longitudinal electric field can be formed along the axis of the tube. The metal vapour can be distributed by cataphoresis similarly to the cataphoretic positive column lasers.

Gas clean up due to cathode sputtering causes problems with every hollow cathode laser. /The sputtered metal may also result in short circuiting between the electrodes/. However, if the temperature of the cathode is only slightly higher than T_1 a metal layer is deposited only on the surface of the cathode and it thereby protects the underlying metal. Sputtering and depositing on the cathode may occur in equilibrium. If this method is used the problem of gas clean up can be solved and this solution can be conveniently combined with the window protecting positive column [53].

d./ Sputtered metal vapour lasers.

Cathode sputtering is a simple method to achieve laser oscillation on metal vapours where the temperature required to produce sufficient 10^{-4} to 10^{-2} torr/ metal vapour pressure is too high /above 1000°C / for practical study.

In a strongly abnormal glow discharge the spectral lines of the cathode material can always be detected. Atoms are released from the cathode surface as high energy particles hit the cathode.

Slotted hollow cathodes are generally used for these lasers with a rather narrow /1.5-2 mm/ slot. With a larger diameter it is difficult to produce the correct metal vapour density. *Figure 14* shows a section of a slotted hollow cathode laser /after Csillag et.al./

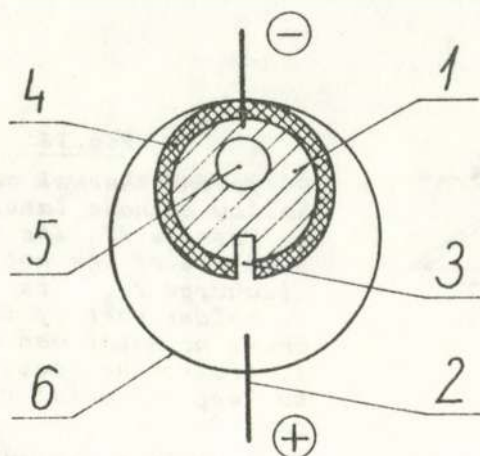

Fig.14

*Slotted hollow cathode laser for cathode sputtered operation.
1. cathode, 2. anode, 3. slot, 4. ceramic insulator, 5. water cooling, 6. glass envelope.*

Laser oscillations were obtained in the spectra of several metals such as Cu [54]-[58] Ag [59][60] Au [61] Al [62][63].

A great number of laser lines now covers the spectrum from the infrared to the 220 nm region.

The respective powers of the strongest lines are comparable with the positive column noble gas ion lasers. All the cw laser lines shorter than 325 nm belong to the sputtered metal vapour lasers.

The characteristic lines are:

Cu II: 259.0 nm, 259.9 nm, 270.3 nm, 467.3 nm, 493.2 nm, 780.8 nm.

Ag II: 224.3 nm, 227.8 nm, 318.1 nm, 478.8 nm, 502.7 nm.

Au II: 282.2 nm, 755.6 nm.

Al II: 692.0 nm, 704.2 nm.

The output power and the wide range of the spectral lines made this type of lasers very promising. On the other hand, the problems of gas clean up due to cathode sputtering and the transition into arc at high current need further investigation before practical lasers can be built taking advantage of the cathode sputtering.

e./ Lasers with volatile compounds of metals.

The experiments of Piper and Neely [64] have shown that halide compounds of metals /CuI, CuCl, CuBr/ give comparable laser performances to the pure metal vapour lasers at low currents. The operating temperature, however, is much lower. The optimum temperature to produce a sufficient pressure of CuCl is 400-420°C.

On the other hand, 1300-1400°C would be necessary to produce sufficient Cu vapour by thermal evaporation.

The excitation mechanism is the following. First the metal compounds dissociate mainly by electron impact in the discharge. The excited metal ions are produced by charge transfer between buffer gas ions and metal atoms. Stable operation can be reached using a cyclic process. Some of the compounds can be re-formed from the elements in the discharge tube at a certain temperature [65].

These lasers operate with considerably lower electrical input than that of the sputtered metal vapour lasers.

Sufficient sputtering occurs only at higher currents. If high voltage hollow cathode discharge /Section 4/ is utilized the threshold current is comparable with the metal halide lasers but the voltage there is higher than that of a conventional hollow cathode laser.

3. MEASUREMENTS ON THE ARC FREE DISCHARGE REGION

a./ Edge protected hollow cathode discharge tube.

In a significant number of laser transitions no saturation has been found as a function of discharge current. However, arcing limits the current. Our aim has been to determine the discharge parameters /current, pressure/ where no arcing occurs. To realize our purpose we took into consideration the following:

- the current should flow only inside the cathode hollow,
- the surface of the cathode covered by discharge should contain neither edges nor tips in order that arcing can be avoided at relatively low current,
- the sputtered metal should deposit only on to metal surfaces it is important that the insulators be kept clean,
- the need to ensure homogeneous temperature along the tube.

Figure 15 shows the realized discharge tube; this tube is simple, seems to fulfil our requirements, and it is easy to attach the electrical contacts and water cooling as none of them should be introduced into the vacuum part of the tube.

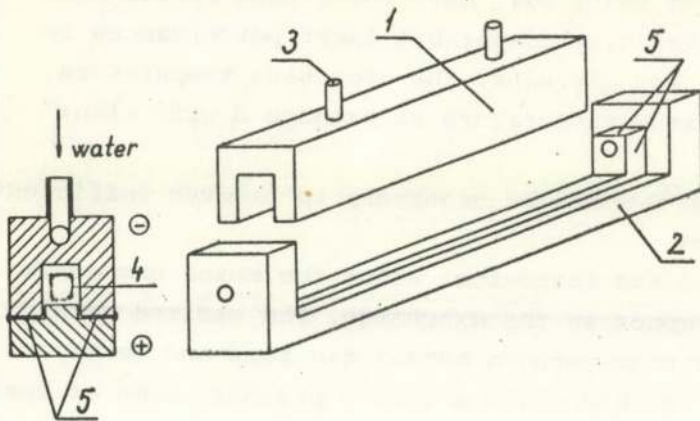

Fig.15

Test tube for measurements on the arc-free region.
1. cathode, 2. anode, 3. water cooling, 4. hollow cathode discharge, 5. space protected against discharge.

The slotted hollow cathode /1/ was made of aluminium, the length of the discharge was 600 mm and the width of the slot was 7 mm. Water cooling was introduced through hole /3/. The anode was situated under the cathode and its shape carefully followed the shape of the lower part of the cathode. Apart from the site of the hollow cathode discharge /4/, everywhere else between the cathode and the anode, 0.5 mm distance /5/ was maintained in order to ensure here, at the pressure range investigated /3-15 torr He, 0.2-2.5 torr Ar/, no discharge exists. Here the discharge would have been strongly obstructed but it does not occur since the voltage of the discharge is too low.

The discharge was excited by half wave rectified a.c. and it proved to be very convenient for our investigations. The current and the voltage as well as arcing could easily be observed on an oscilloscope. Continuous arcing may easily damage the tube. With pulsed operation, however, even if the glow changes into arc the current stops at the end of the pulse.

The cleaning process of the discharge tube was performed by filling the tube with some 5 torr He and switching on the discharge for a short period. The tube was then evacuated and this process was repeated several times until the tube was prepared for measurements, /shown by the spectrum of the He and by about 10^{-7} torr pressure in the tube during evacuation/.

During this period, together with the improving cleanness of the tube, the discharge current which caused no arcing could also be increased day by day. This feature shows the strong relationship between impurities and arcing.

b./ The arc free region of the hollow cathode discharge.

Investigations were performed on He, Ar, He-Ne mixtures and on He containing $6 \cdot 10^{-3}$ torr Kr.

We observed that a fixed pressure and a given peak current - whether or not the discharge changed into an arc - were statistical phenomena. Nevertheless, a critical current I_{crit} could be defined. In the case of about 300 mA less than I_{crit} arcing hardly occurred, whereas when we tried to increase the current further than this threshold almost every pulse produced arcing. The results of our measurements are presented in Figs. 16, 17, 18 and 19 where I_{crit} is shown as a function of gas pressure for different gases and gas mixtures.

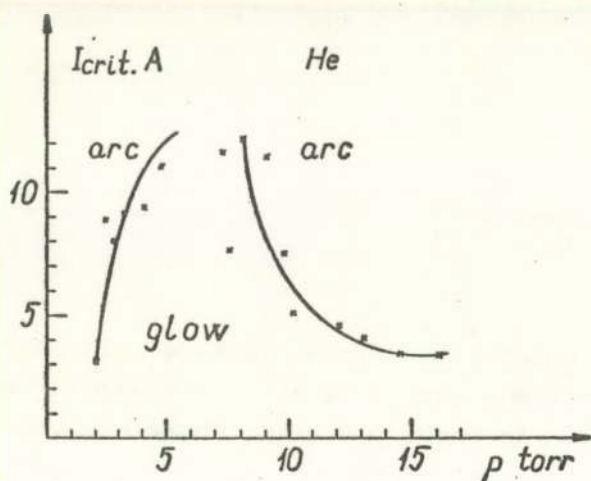

Fig. 16

Critical arcing threshold current as a function of gas pressure in He. Below the curve is the arc free glow discharge.

Figure 16 shows the critical current in pure He. The area below the curve is the arc free region. Above 10 and below 2.5 torr the glow discharge is stable only at relatively low current. The curve has a maximum at about 7 torr where no arcing occurs even at the highest current investigated (12 A).

It is interesting to note that this optimal pressure is close to the pressure corresponding to the hollow cathode effect.

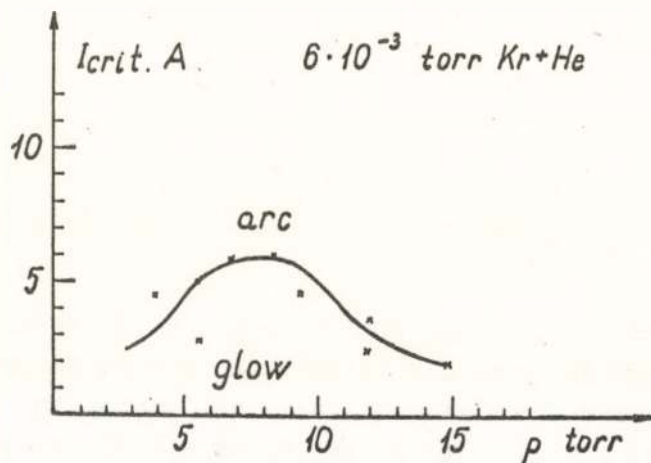

Fig. 17

Critical current in He containing $6 \cdot 10^{-3}$ torr krypton.

Figure 17 shows that the critical current in He with traces of Kr is much less than in pure He. Thus traces of Kr have a similar effect to the other impurities when the tube is being prepared for measurements.

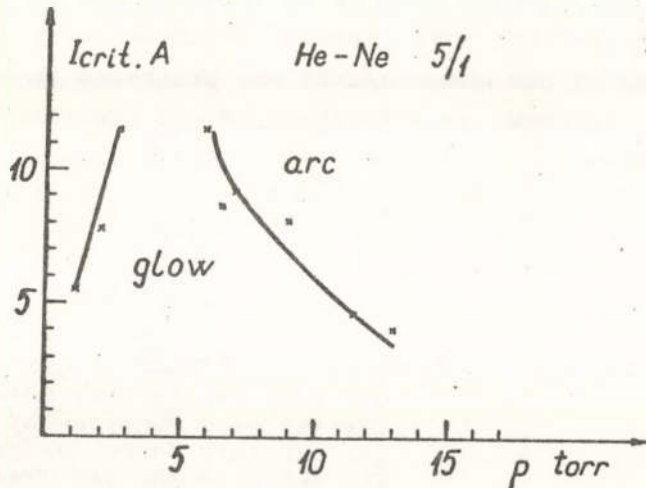

Fig.18
Critical current in He-Ne mixture

Figures 18 and 19 show the critical current in a He-Ne mixture and in Pure Ar, respectively. In He-Ne /5:1/ the optimum pressure is less /3-6 torr/ than in pure He. In Ar the optimum pressure is about 0.9 torr. These pressure are also close to the corresponding pressure of the hollow cathode effect.

In order to determine the dependence of the critical current on the cathode length similar investigations were performed with 100 and 200 mm long cathodes.

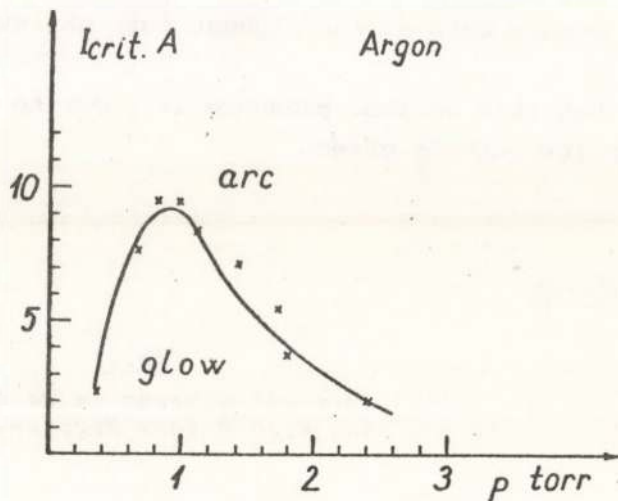

Fig.19
Critical current in Ar.

On comparing the results with those of the 600 mm long cathode we found that within the experimental error the threshold current did not depend on the length of the cathodes. As a conclusion we can state that arcing depends on total current rather than on current density on the cathode surface /at least in the current density range investigated/.

According to our measurements lasers like that in *Fig. 11* should be very stable against arcing. Such lasers have several cathode segments and each of them is connected with a resistance to ensure equal current on the segments.

In such constructions high current can be achieved by summing up the currents of the individual cathodes. When using this type of discharge we found cw laser operation at the 476.5 nm transition of Ar II in a He-Ar mixture [66].

Furthermore, in our experiments we found the interesting result that the critical current can also be doubled by connecting, electrically, two independent cathodes with no resistance at all. /E.g. At a certain pressure the critical current both at 10 and 20 cm cathodes is 5 A. In spite of this, with two electrically connected 10 cm cathodes the critical current is 10 A/. This result shows that the division of the discharge itself has some basic importance.

c./ Division of the discharge region.

Our simplified model for arcing is that in the continuous discharge plasma the ion density has fluctuations; when the local ion density reaches a critical value the ions start to heat a small part of the cathode surface to a temperature at which the voltage necessary to sustain the discharge starts to decrease mainly due to thermionic electron emission; after this point a positive feedback exists and the discharge contracts into an arc.

This critical density may be a function of the total number of ions, and is supposed to be roughly proportional to the total current since the voltage is practically independent of the current if the pressure is not too low.

In the light of this consideration the concept of the critical current is related to one independent part of the discharge. Thus, on increasing the number of these independent parts the critical current even at a single cathode should also be increased. In view of this, we altered our original discharge tube. The cathode remained unchanged and the anode was modified to divide the discharge. This was done by inserting small metal prisms into the anode. Their shape followed the shape of the cathode hollow keeping 0.5 mm distance between them and the cathode surface. It was supposed that these metal prisms divided the discharge, they were at anode potential and thus repelled the ions. We also supposed that these dividing elements would be effective even if they were placed only in the cathode dark space leaving the centre of the cathode hollow free for the optical path. The improved discharge tube is illustrated in *Fig. 20*.

Applying this method, we divided the discharge into eight parts of equal length. The discharge tube fulfilled our expectations. Because of the limited current of our power supply we could not determine the critical current of the modified tube in the whole pressure region investigated, but

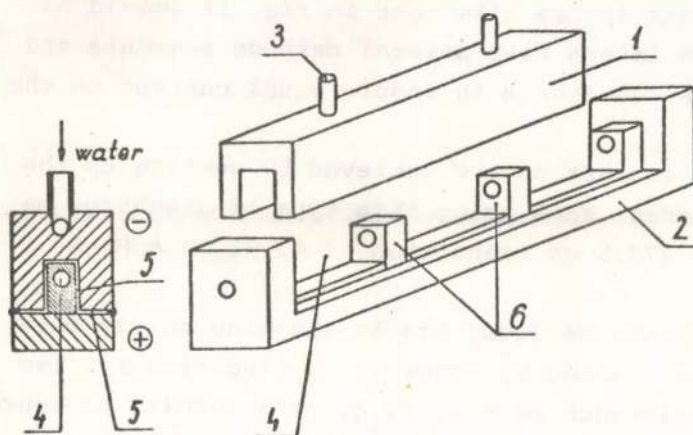

Fig.20

Hollow cathode discharge tube with divided discharge. 1. cathode, 2. anode, 3. water cooling, 4. discharge region, 5. parts protected against discharge, 6. additional parts of the anode to divide the discharge.

in He between 3 and 13 torr and in Ar between 0.4 and 2.1 torr no arc occurred up to 15 A. We were able to perform investigations on a He-Kr laser up to 10 A while the partial pressure of the Kr was 0.05 - 0.23 torr. In the discharge tube of Fig.15 arcing prevented us from obtaining laser oscillation.

Although some results have been obtained in the construction of high current hollow cathode lasers a number of questions are still open. Since measurements have been performed only by half wave rectified a.c., the critical current only means that at currents below it the arc formation time is longer than 6-8 msec. If shorter pulses are used the arcing threshold is certainly higher while it may be lower with d.c. excitation. The dependence of the critical current on pressure also needs further understanding. The dependence of arcing threshold at higher than the optimal pressure has some similar features to the noisy state of the positive column. At a certain pressure and plasma geometry a threshold current exists where the positive column discharge becomes very noisy [67][68].

This threshold current decreases with increasing pressure and with increasing partial pressure of the lower ionization potential component in gas mixtures. The threshold current can also be increased by dividing the discharge into several parts. It is conceivable that fluctuations that cause noise in the positive column produce a critical local ion density that causes arcing in a hollow cathode discharge. However, the source of ion density fluctuation can be the fluctuation of electron density as well. The stabilizing prisms are places where electrons enter into the anode, thus they can reduce the electron density fluctuation [69]. With meshed anodes higher current was achieved at cathode sputtered hollow cathode lasers using 200 μ s excitation pulses [61].

At low pressure the critical current rapidly decreases. This phenomenon can be explained by the rapid increase in voltage at pressures lower than that corresponding to the hollow cathode effect [see Fig.4]. Even small fluctuations may be amplified to the critical value by the high voltage of

the discharge. However, no measurements have been performed to determine whether or not the pressure that is optimal for stability corresponds to the pressure of the hollow cathode effect for different diameters as well.

4. VARIABLE VOLTAGE HOLLOW CATHODE DISCHARGES AND LASERS

The density of high energy electrons essential in laser excitation could be increased by increasing the cathode fall - which can be regarded here as the voltage of the discharge. However, the voltage is mainly determined by the gas pressure and the hollow cathode diameter in a given gas, and it is not worth changing any of them in order to increase the voltage.

Higher voltages have been up to now achieved by decreasing the pressure or the hollow cathode diameter. In both cases it would mean decreasing the number of particles that could be used for laser oscillation. Furthermore, with low pressures the discharge is not stable either, as the critical arcing current is low. Changing the current has but little effect on voltage.

In this section a short summary is given on experiments where the voltage could be increased by using a special anode geometry.

a./ Variable voltage hollow cathode discharges.

The concept of the variable voltage is an application of the obstructed discharge and can be seen in *Fig. 21*.

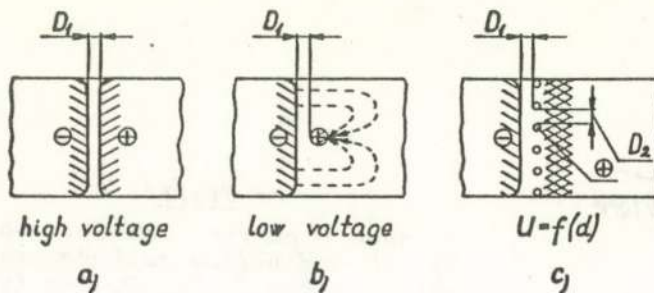

Fig. 21

Discharge arrangements with constant anode cathode distances but different voltages. D_1 and D_2 are the dimensions for determining the voltage.

A distance between the electrodes should be assumed at which the given pressure [see *Fig. 21/a*] is small enough for a high voltage obstructed discharge. In *Fig. 21/b*, however, the voltage is certainly lower in spite of the same anode-cathode distance, as the electrons have paths long enough for the necessary ionization. If a mesh is utilized for the anode [*Fig. 21/c*], any voltage can be expected between the voltages of the 21/a and 21/b tubes if the dimensions of the holes of the mesh [D_2] are properly chosen.

Connecting this idea with hollow cathode discharge, we built hollow cathode internal anode systems [70] in the arrangements shown in *Fig. 22*.

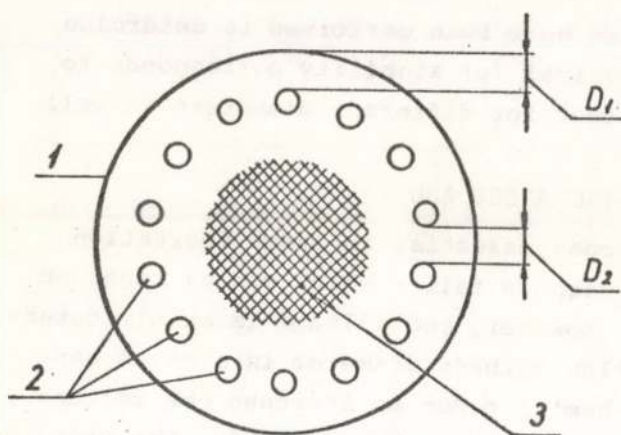

Fig. 22

Principle of hollow anode cathode /HAC/ discharge. 1. cathode 2. anodes, 3. bright part of the discharge. D_1 and D_2 are the dimensions for determining the discharge voltage.

The current-voltage characteristics and the optical spectra of two HAC discharge tubes were measured and compared with a conventional hollow cathode discharge.

The important geometrical parameters were: length of the cathodes 20 mm; the inner diameter 10 mm; distance between the anode-circle and the cathode surface [D_1 in Fig. 22] 1 mm. The anodes were 0.6 mm diameter tungsten rods and the gaps between them [D_2 in Fig. 22] were 0.55 and 0.95 mm, respectively. The voltage - current characteristics obtained at different He pressures are shown in Fig. 23.

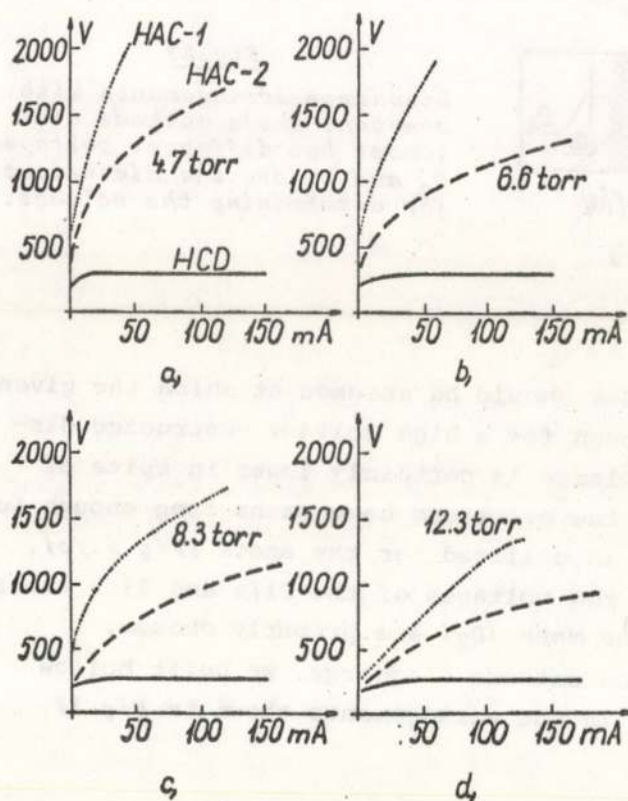

Fig. 23

Voltage - current characteristics of HAC and hollow cathode discharge tubes in He. Dotted lines; HAC discharge with 0.55 mm distance between the anodes. Broken lines: 0.95 mm distance. Continuous lines: hollow cathode discharge.

It can be seen from the figure that in the range investigated, the gas pressure, discharge current and voltage can be chosen independently of each other by varying the gaps $/D_2/$ between anodes. The distance D_1 should be smaller than the length of the cathode dark space at the given pressure. Some lines of the optical spectra measured in He and in Ar are presented in Table 1.

	Hollow cathode		HAC
Helium	P = 8.1 torr		P = 8.1 torr
	I = 130 mA		I = 120 mA
	U = 271 V		U = 1880 V
HeI 587.6 nm	1400		3200
HeI 501.6 nm	180		550
HeII 468.6 nm	2.5		15
HeI 388.8 nm	280		340
Argon	P = 3 torr		P = 3 torr
	I = 260 mA		I = 260 mA
	U = 370 V		U = 1120 V
ArI 425.2 nm	7		2.5
ArI 415.9 nm	15		10
ArII 514.5 nm	0.5		3
ArII 488.0 nm	14		40
ArII 372.9 nm	1.5		6
ArIII 379.5 nm	<0.1		0.5

Table 1. Relative intensities of some He and Ar spectral lines obtained in HAC and in hollow cathode discharge.

Due to the increased voltage, in He the whole spectrum is more intense. However, the increase in the intensity of ionic lines is much more significant. In Ar, such ionization can be produced that the intensity of the atomic spectral lines decreases. The ionic lines are, of course, much stronger and the lines of Ar III also become detectable.

The electron energy distribution was investigated for a similar geometry by Soldatov [71] but lower values of pressures and current were used.

A peak in the electron energy distribution was found at 20 eV. The intensity ratio of the high and low energy peak was unusually high.

Our recent investigations [72] resulted in some further development in

this type of discharge. In the hollow cathode discharge the plasma potential can be assumed as being equal to the anode potential everywhere except in a small region near the cathode. In view of this, a high voltage hollow cathode discharge is also expected if we allow the grid /that originally served as the anode/ to have floating potential and use a separate anode. Experimentally measured voltage - current characteristics showed only a negligible difference between the HAC discharge and the discharge when the grid was at floating potential.

In both discharges the cathode surface is divided into small independent parts. In the HAC discharge the anode wires divide the discharge on the cathode surface. The same effect occurs if this grid is at a floating potential which is practically equal to the anode potential.

The loss of charges in such discharge is high since a part of ions and electrons can diffuse out of the discharge region /across the borders of the small independent discharges/ and can recombine.

To compensate for the greater loss of ions, a higher voltage is needed. The electrons need greater energy to produce the necessary number of ions to hit the cathode surface.

The importance of the division of the discharge was demonstrated in the discharge tube shown in *Fig.24* [72]. This tube had similar geometry and the same number of anode rods as a high voltage hollow cathode discharge tube but the anode rods were arranged in the way shown in the figure in order to leave two comparatively large free surfaces for the discharge at the cathode.

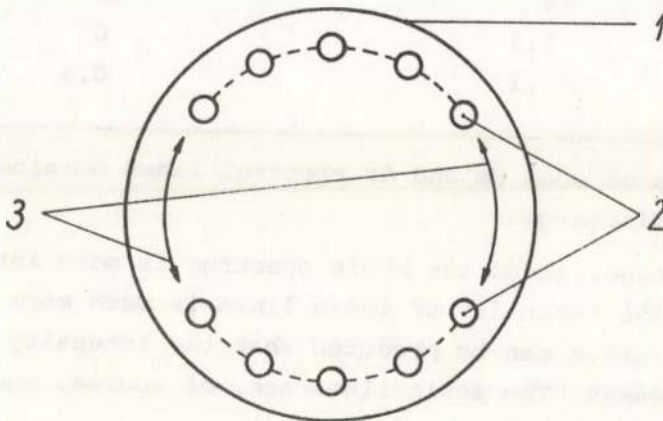

Fig.24

Test tube for studying the effect of dividing the discharge. 1. cathode, 2. anodes 3. large uninterrupted surfaces for the discharge.

This tube, due to the large uninterrupted surfaces at the cathode, showed very similar behaviour to the conventional low voltage hollow cathode discharge.

In view of this consideration higher voltage was also found when the distance between the anodes and cathode surface $/D_2$ in Fig.22/ was zero, i.e. the working surface of the hollow cathode and that of the anodes were on the same cylinder jacket. Such a tube can be seen in Fig.25.

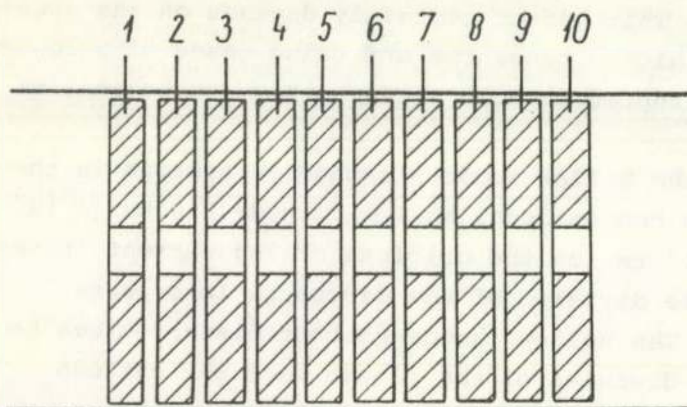

Fig.25

Test tube with uninterrupted cathode surfaces of variable size. 1-10 represent insulated metal disks which can be either cathodes or anodes.

The main geometrical data were the following: The electrodes were stainless steel disks of 2 mm thickness with 5 mm diameter holes, all of which were contained in a glass envelope. The distance between each electrode was 0.1 mm.

Each electrode had a separate electrical contact which thus enabled us to switch on discharges with different sizes of independent cathode surfaces. If we put 1, 3, 5, 7, ... as anodes and 2, 4, 6, ... as cathodes, one cathode segment is 2 mm long. If we use 1, 4, 7, ... as anodes and 2-3, 5-6, ... as cathodes, then one cathode segment is 4 mm etc. Although there is a small gap between the two cathode segments /e.g. when the electrodes 2-3 act as a single cathode element/ its surface is still uninterrupted since above or near the surface there is no anode dividing the discharge. Figure 26 shows the current-voltage characteristics of this tube measured in He.

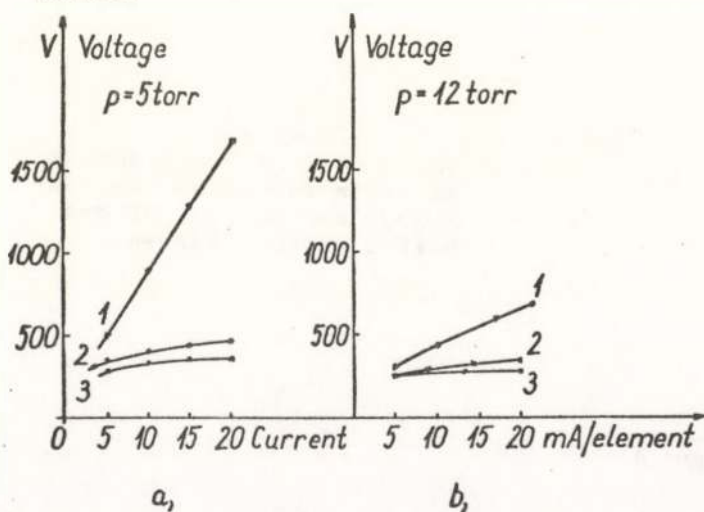

Fig.26

Current-voltage characteristics of the segmented hollow cathode discharge tube measured in He. 1. each cathode segment is 2 mm; 2. the segments are 4 mm; 3. the segments are 6 mm; a. P=5 torr, b. P=12 torr.

It can be seen from the figure that a high voltage hollow cathode discharge can also be constructed having the anode and cathode on the same surface. If the cathode segments are 4 mm long the voltage is still somewhat higher than the voltage of the conventional hollow cathode discharge. At still longer cathode segments the discharge goes over into the conventional hollow cathode discharge. This effect certainly depends on the pressure and on the working gas. At higher pressures and using gases with lower ionization potential the uninterrupted cathode surfaces have to be smaller to obtain high voltage.

An interesting feature of the hollow anode - cathode discharge is the stability against arcing. With a conventional hollow cathode discharge in the higher voltage /low pressure/ region the critical arcing current is very low /see Section 3/. However, the division of the discharge into parts increased the critical current. The hollow anode-cathode discharge can be regarded as a much more compact division of the plasma near the cathode surface thus making the discharge stable even at some 2000 V voltage.

b/ Lasers in hollow anode-cathode discharge.

The strong ionic spectra of the hollow anode cathode discharge suggest that lasers utilizing the charge transfer reactions should be the most promising subjects for HAC lasers. Even so, most of the investigations carried out so far have been performed on noble gas mixtures because of the simplicity of these lasers [30][31][73].

The arrangement of the discharge was similar to that in *Fig. 23*. The geometrical data of the laser tube were the following: active length 400 mm, cathode diameter 7 mm, anode rod diameter 1.2 mm, $D_1 = 0.5$ mm, $D_2 = 1.3$ mm.

The dependence of laser power on discharge current shows that the threshold current is very low, and the power of the laser rapidly increases to a value higher than had formerly been produced while the current is still lower than the threshold current of the hollow cathode laser of similar geometry [*Fig. 27*].

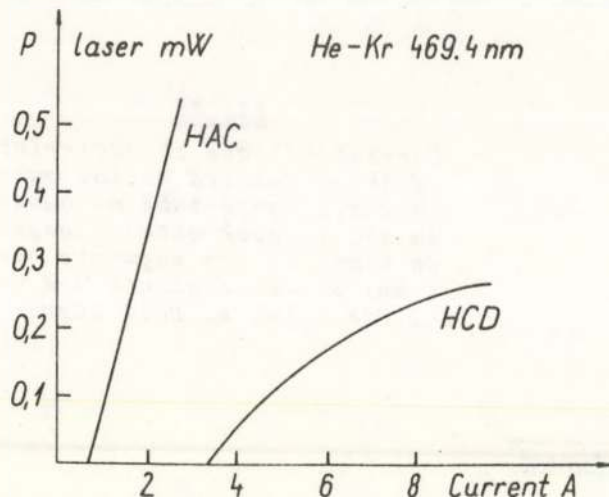

Fig. 27

Dependence of laser output power on instantaneous discharge current in HAC and hollow cathode lasers.

In the case of the 467.5 nm Ar II laser line, four times higher power was achieved in HAC than in the hollow cathode laser.

Cw laser oscillations were found at the 531.4 nm and 486.3 nm transitions of Xe II in He-Ne-Xe mixtures. These transitions had been predicted to operate as cw laser lines in hollow cathode discharges [74].

In a similar laser tube with a length of 1600 mm further new cw laser lines were found: Kr II: 651.0 nm 512.6 nm 458.3 nm 438.7 nm 431.8 nm. Ar II: 686.1 nm 648.3 nm . The 457.9 nm and 454.5 nm Ar II lines were first observed in a hollow cathode He-Ar discharge. The laser output at 469.4 nm Kr II exceeded 100 mW and the measured gain on this line reached 10 %/m. For the 431.8 nm Kr II line when the 469.4 nm oscillation was suppressed a power of 20-30 mW was obtained.

Recently continuous laser operation was found on all of these lines also in conventional hollow cathode discharges at relatively high currents [28] [34] [75].

Measurements were also carried out on cathode sputtered HAC lasers [76] [77]. The hollow anode - cathode lasers cannot easily be built with a 1-2 mm hollow cathode diameter. The possibility of reaching appropriate metal vapour concentration in a 0.7 cm diameter hollow cathode originally seemed to be problematic but the threshold current of these lasers was found to be less than half of the threshold current of the formerly reported cathode sputtered lasers.

It is questionable, however, whether the low threshold is due to the increased efficiency of the excitation or whether the efficiency of the cathode sputtering increases with the higher energy of the ions hitting the cathode surface due to the higher voltage.

No measurements have been performed so far on how cathode sputtering depends on voltage if we keep both the current and gas pressure constant.

The constructions of the HAC lasers are certainly somewhat more complicated than those of hollow cathode lasers. Even so, preliminary results show these lasers to be promising for further investigations.

Different other arrangements for changing the electron energy distribution can be built using grids, etc., but it must be kept in mind that according to the potential given to such elements additional discharges can be formed. As the utilization of the obstructed discharge seemingly solves this problem, the regions near the electrodes appear to be the most promising parts for such investigations. The voltage drop at the anode region was also recently utilized to obtain laser oscillation in Ar II [78]. The wall of the discharge tube can also be used for stabilization and for changing the energy of electrons in transversal discharge as well [79].

ACKNOWLEDGMENTS

The work was supported in part by the State Office for Technical Development. I should like to acknowledge the fact that every part of this paper has been discussed with Drs. J. Bergou, L. Csillag and M. Jánossy. The interest in this work and the continuous efforts of Prof. N. Kroó to obtain financial support for hollow cathode laser research is highly appreciated. I acknowledge with pleasure helpful discussions on parts of this work with Prof. S. Hattori /Nagoya University/, Prof. G.J. Collins /Colorado State University/, Drs. F. Howorka and I. Kuen /University of Innsbruck/, Prof. S.I. Anisimow /Landau Theoretical Physical Research Institute, Moscow/, Dr. E. Fazekas /Polytechnical University of Budapest/, Drs. F. Halász and K.G. Antal /Tungstram Research Laboratory, Budapest/, and Prof. J.S. Bakos /Central Research Institute for Physics, Budapest/.

Thanks are due to Mr. J. Tóth for the mechanical construction work, to Mr. A. Majorosi for the expert glassblowing and to Miss J. Forgács for the technical assistance.

Special thanks to Dr. F. Howorka and Dr. M. Jánossy for the careful reading and correcting the manuscript.

REFERENCES

- [1] G. Francis: The glow discharge at low pressure. Handbuch der Physik, 22, 53 /1956/
- [2] A. von Engel, M. Steenbeck: Elektrische Gasentladungen. Berlin, Springer 1962, 1934.
- [3] P.H. Pringle, W.E.J. Farvis: Phys. Rev. 96, 536 /1954/.
- [4] P. Gill, C.E. Webb: J. Phys. D. Appl. Phys. 10, 299 /1977/.
- [5] M. Pahl: Z. Naturforsch. 27a, 1812 /1972/.
- [6] P.F. Little, A. von Engel: Proc. Roy. Soc. A-224, 209 /1954/.
- [7] K. Fujii: IEEE. J. of Quantum Electron QE-15, 35 /1979/.
- [8] H. Störi, T.D. Märk, R.N. Varney, M. Pahl: Plasmaphysik 18, 79 /1978/.
- [9] H. Helm, F. Howorka, M. Pahl: Z. Naturforsch. 27a, 1417 /1972/.
- [10] K. Rózsa: Investigations on the spectra of He-Kr gas mixtures in hollow cathode discharge /In Hungarian/ Thesis, Polytechnical University, Budapest, 1974.
- [11] P. Gill: Charge Transfer as a Laser Excitation Mechanism, Thesis, Oxford University, 1975.
- [12] K. Fujii: Japan J. Appl. Phys. 16, 1081 /1977/.
- [13] I. Kuen, H. Störi, F. Howorka: to be published
- [14] F. Howorka: J. Chem. Phys. 68, 804 /1978/.
- [15] F. Howorka, M. Pahl: Z. Naturforsch. 27a, 1425 /1972/.
- [16] Y. Sugawara: Study on the cw Laser Oscillations in He-Cd and a Hollow Cathode Discharge /in Japanese/ Thesis, Seikei University, Tokyo, 1975.
- [17] I. Kuen: Untersuchungen zur kinetik positiver und negativer Ionen in einer stationären hohlkatodenladung. Thesis, University of Innsbruck, 1979.
- [18] F. Howorka, I. Kuen: J. Chem. Phys. 70, 758 /1979/.
- [19] I. Kuen, F. Howorka, R.N. Varney: Int. J. Mass Spectrom. 28, 101 /1978/.
- [20] I. Kuen, F. Howorka: J. Chem. Phys. 70, 595 /1979/.
- [21] F. Howorka, W. Lindiger, M. Pahl: Int. J. Mass Spectrom. 12, 67 /1973/.
- [22] E.K. Karabut, V.S. Michalevskii, V.F. Papakin, M.F. Sem: J. Techn. Phys. 39, 1923 /1969/.
- [23] Y. Sugawara, Y. Tkoiwa: Japan J. Appl. Phys. 9, 588 /1970/.

- [24] W.K. Schuebel: IEEE J. Quantum Electron QE-6, 547 /1970/.
- [25] J.K. Mizeraczyk: private communication
- [26] J. Piper, C.E. Webb: J. Phys. D. Appl. Phys. 6, 400 /1973/.
- [27] K. Fujii, T. Tkashi, Y. Asami: IEEE J. Quantum Electron QE-11, 111 /1975/.
- [28] N.K. Vuchkov, M.G. Grozeva, N.V. Sabotinov: Opt. Comm. 27, 114 /1978/.
- [29] M. Jánossy, L. Csillag, K. Rózsa, T. Salamon: Phys. Lett. 46A, 379 /1974/.
- [30] M. Jánossy, K. Rózsa, L. Csillag, J. Bergou: Phys. Lett. 68A, 317 /1978/.
- [31] K. Rózsa, M. Stefanova, M. Jánossy: KFKI-1979-11
- [32] Y. Pacheva, M. Stefanova, P. Pramatorov: Opt. Comm. 27, 121 /1978/.
- [33] M. Jánossy, L. Csillag, K. Rózsa: Phys. Lett. 63A, 84 /1977/.
- [34] Y. Pacheva, P. Pramatorov, M. Stefanova: Opt. Comm. 31, 203 /1979/.
- [35] W.K. Schuebel: Proceedings of Phen. Ion. Gases. Prague. 1973. p. 174.
- [36] S.S. Kartaleva, V.I. Stefanov, D.S. Dimitrova: Zhurnal Prikladnoy Spectroscopy 30, 816 /1979/.
- [37] L. Dana, P. Laures: Proc. of the IEEE, 53, 78 /1965/.
- [38] M. Jánossy, P. Tuovinen: To be published in Acta Phys. Hung. 46/3.
- [39] L. Csillag, C.Z. Nam, M. Jánossy, K. Rózsa: Opt, Comm. 21, 39 /1977/.
- [40] Y. Sugawara, Y. Tokiwa, T. Iijama: Japan J. Appl. Phys. 9, 1537 /1970/.
- [41] G.J. Collins: Cw Oscillation and Charge-exchange Excitation in the He-Zn Laser. Thesis, Yale University /1970/.
- [42] J.A. Piper, P. Gill: J. Phys. D: Appl. Phys. 8, 127 /1975/.
- [43] J.A. Piper, G.J. Collins, C.E. Webb: Appl. Phys. Lett. 21, 203 /1972/.
- [44] J.A. Piper: J. Phys. D. Appl. Phys. 7, 323 /1974/.
- [45] J.A. Piper, C.E. Webb: Opt, Comm. 13, 122 /1975/.
- [46] J.A. Piper, C.E. Webb: J. Phys. B. 6, L-116 /1973/.
- [47] M.G. Grozeva, N.V. Sabotinov, N.K. Vuchkov: Opt. Comm. 29, 339 /1979/.
- [48] T. Shay, H. Kano, G.J. Collins: Appl. Phys. Lett. 26, 531 /1975/.
- [49] G.J. Collins, R.C. Jansen, W.R. Bennett, Jr.: Appl. Phys. Lett. 18, 282 /1971/.
- [50] S. Chinen, S. Hattori: J. Appl. Phys. 48, 3603 /1977/.

- [51] G.J. Collins: J. Appl. Phys. 44, 4633 /1973/
- [52] S. Hattori: private communication
- [53] K.G. Hernqvist: IEEE. J. of Quantum Electron. QE-13, 64 D /1977/.
- [54] L. Csillag, M. Jánossy, K. Rózsa, T. Salamon: Phys. Lett. 50A, 13 /1974/.
- [55] J.R. Mc Neil, G.J. Collins, K.B. Persson, D.L. Franzen: Appl. Phys. Lett. 27, 595 /1975/.
- [56] J.R. Mc Neil, G.J. Collins, K.B. Persson, D.L. Franzen: Appl. Phys. Lett. 28, 207 /1976/.
- [57] K.G. Hernqvist: IEEE J. Quantum Electron QE-13, 929 /1977/.
- [58] J.J. Eichler, H. Koch, J. Salk, G. Schäfer: To be published in IEEE J. Quantum Electron 1979. Sept.
- [59] W.L. Johnson, J.R. Mc Neil, G.J. Collins, K.B. Persson: Appl. Phys. Lett. 28, 101 /1976/.
- [60] J.R. Mc Neil, W.L. Johnson, G.J. Collins, K.B. Persson: Appl. Phys. Lett. 29, 172 /1976/.
- [61] R.D. Reid, J.R. Mc Neil, G.J. Collins: Appl. Phys. Lett. 29, 666 /1976/.
- [62] D.C. Gerstenberger, R.D. Reid, G.J. Collins: Appl. Phys. Lett. 30, 466 /1977/.
- [63] W.K. Schuebel: Appl. Phys. Lett. 30, 516 /1977/.
- [64] J.A. Piper, D.F. Nelly: Appl, Phys. Lett. 33, 621 /1978/.
- [65] J.A. Piper: "Use of volatile metal compounds for operation of cw metal ion lasers" SPIE. Proc. Lasers '78. 168-45. Florida, 1978.
- [66] M. Jánossy, L. Csillag, K. Rózsa: Phys. Lett. 63A, 84 /1977/.
- [67] T. Suzuki: Japan J. Appl. Phys. 7, 788 /1968/.
- [68] K. Rózsa, T. Salamon: Opt. and Laser Tech. 2, 151 /1970/.
- [69] S.I. Anisimov: private communication
- [70] K. Rózsa: KFKI-1975-63
- [71] A.N. Soldatov: Optics and Spectr. 31, 181 /1971/.
- [72] K. Rózsa, J. Bergou, M. Jánossy, J.K. Mizereczyk: KFKI-1979-15.
- [73] K. Rózsa, M. Jánossy, J. Bergou, L. Csillag: Opt. Comm. 23, 15 /1977/.
- [74] M. Jánossy: Investigations on Two Components Ion Gas Lasers /In Hungarian/. Thesis, R. Eötvös University, Budapest, 1974.
- [75] R. Salanski, E.L. Latush, D.C. Gerstenberger, W.M. Fairbank, Jr., G.J. Collins: Appl. Phys. Lett. 35, 317 /1979/.
- [76] K. Rózsa, M. Jánossy, L. Csillag, J. Bergou: Phys. Lett. 63A, 231 /1977/.

- [77] K. Rózsa, M. Jánossy, L. Csillag, J. Bergou: Opt. Comm. 23, 126 /1977/.
- [78] H.J. Eichler, K. Richter, J. Salk, G. Schäfer, U. Weigmann: Phys. Lett. 57-A, 455 /1976/.
- [79] G. Schäfer, J. Salk, H.J. Eichler, J. Eichler: Appl. Phys. 14, 193 /1977/.







Kiadja a Központi Fizikai Kutató Intézet
Felelős kiadó: Krén Emil
Szakmai lektor: Jánossy Mihály
Nyelvi lektor: Harvey Shenker
Példányszám: 340 Törzsszám: 80-103
Készült a KFKI sokszorosító üzemében
Budapest, 1980. február hó