

Holographic Aspects of Temporal Memory and Optomotor Responses

A. BORSELLINO and T. POGGIO*

Istituto di Scienze Fisiche, Genova, Italy
 Laboratorio di Cibernetica e Biofisica del CNR, Camogli, Italy

Received August 2, 1971

Abstract. A mathematical analogy between the holographic models of temporal memory and Reichardt's optomotor theory is stressed. It is pointed out that the sequence of operations which is essential to any holographic model of brain functioning is actually carried out by a nervous structure in the optomotor behaviour.

Some implications in both the optomotor theory and the hypothesis of neural holographic processes are further suggested.

The optomotor response of insects (their evoked response to movement relative to themselves in their visual surroundings) allows, through a quantitative system analysis, the specification of some fundamental functional principles of the central nervous system (Reichardt, 1969).

It is not necessary for our purpose to specify all the experimental and theoretical details, otherwise well known (see for example Reichardt, 1957). Highly reproducible experiments lead to undoubtable conclusions about the existence of physiological mechanisms able to connect sensory input and motor output in a well defined manner.

A model, devised by Reichardt, accounts for the functional properties of the neurophysiological system. The model is a network of linear filters, the weighting functions of which are fitted by analyzing the experimental data. It allows a very accurate prediction of insect's responses to previously untested stimulus patterns.

The model (Fig. 1) envisages two cross-connected information channels from two input units *A* and *B* (the elementary event which evokes an optomotor response consists of a sequence of two light stimuli impinging on two adjacent receptors). The two input elements transform the light stimulus into the time functions L_A and L_B which are determined by the structure and speed of the pattern. The functions L_A and L_B are further transformed by a succession of components that carry out linear transformations, multiplication and time averaging.

If we designate with W_{DF} and W_{DH} the weighting functions on the channels and with Φ_{GG} the auto-correlation function of the light-flux fluctuation $G(t)$, then we obtain according to the model and on the basis of all the experimental conclusions—the following expression for the optomotor response

$$R(\Delta t) = \int_0^\infty W_{DF}(\eta) d\eta \int_0^\infty W_{DH}(\xi) \Phi_{GG}(\eta - \xi - \Delta t) d\xi - \int_0^\infty W_{DH}(\eta) d\eta \int_0^\infty W_{DF}(\xi) \Phi_{GG}(\eta - \xi - \Delta t) d\xi \quad (1)$$

the equivalent of which in the frequency domain is

$$R(\Delta t) = \frac{1}{2} \int_{-\infty}^\infty Y_D Y_D^* (Y_F Y_H^* - Y_F^* Y_H) S(\omega) e^{i\omega \Delta t} d\omega. \quad (2)$$

* Present address: Max-Planck-Institut für Biologische Kybernetik, Tübingen, Germany

Y_D, Y_F, Y_H are transfer functions of the filters and $S(\omega)$ is the spectral density of $G(t)$, related to Φ_{GG} through the Wiener's theorem.

It does not matter if $G(t)$ is a periodic stimulus or a random distribution of light points: in both cases the predictions fit perfectly the experimental findings (Reichardt, 1969).

The exact localization of the anatomical structures underlying the optomotor behaviour is still an unsolved problem. Many aspects however are now quite clear.

Some histological sections of the first optic ganglion—the lamina—have sometimes been considered as an indication that the pattern of fibers from retina to lamina may be isomorphic to the information flow diagram of Fig. 1. As a matter of fact the projection of fibers from neighboring ommatidia in one element of the lamina (cartridge) is well compatible with the Reichardt's scheme. Braitenberg (1967) and Kirschfeld (1967) demonstrated that this localization cannot be upheld any more. While it is true that fibers from different ommatidia come together in one cartridge,

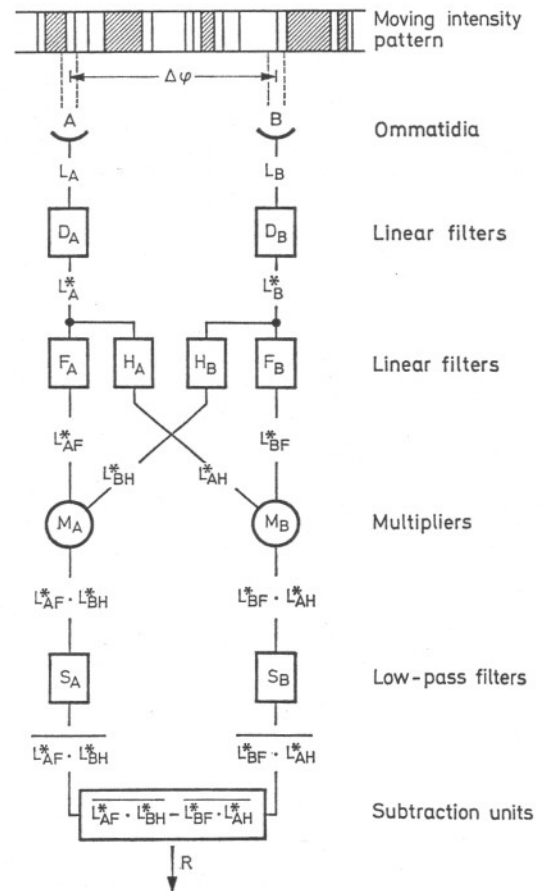

Fig. 1. Reichardt's model describing stimulus-reaction relations of optomotor responses (from Reichardt, 1969)

these fibers collect information from one point of the environment only, detected by six retinula cells in six different ommatidia. Consequently the projection between retina and lamina is such that an individual cartridge does not receive information from two distinct points of the environment, a necessary condition for any correlation model (Reichardt, 1969).

The lamina however can not yet be excluded as a possible localization for movement detection since a precise pattern of lateral interconnections between triplets of cartridges have been recently discovered (Strausfeld and Braitenberg, 1970). Although the topology of these connections is in principle the same that would be required by the minimal Götz's (1968) motion detector model, some preliminary findings by Kirschfeld (1971) suggest other connections too. Kirschfeld had just succeeded in obtaining optomotor reactions by stimulating selected pairs of rhabdomeres within one ommatidium. Actual combinations, effective in eliciting optomotor responses, seem to require other connections in addition to those found by Braitenberg, possibly in the lobula. Only further structural work at this level will answer the problem.

We will now consider the Reichardt's model in its mathematical aspect only. From this point of view Eq. (1), characterising optomotor behaviour, shows the same mathematical structure underlying the most general holographic transformation, namely convolution of some function with the autocorrelation of a key signal. We particularly notice that the holographic model of temporal recall proposed by Gabor (1968a, 1968b) is mathematically identical to Eq. (1). As an implementation of the holophone concept first introduced by Longuet-Higgins (1968)—Gabor suggested and discussed (Gabor, 1969) a general analogue in the temporal domain of the association properties of holography. In particular Gabor presented two two-steps transformations imitating the recording-reconstruction sequence in holography. The first of them is a succession of a convolution and a correlation: the way of making a record is to convolve the key sequence A with B . To recall B , we form the cross-correlation of the record with A' , where A' is a fragment of A .

Essentially the Gabor's model requires the record of

$$\Psi_{BA}(\xi) = \int B(\tau) A(\xi - \tau) d\tau \quad (3)$$

that is, with the convolution symbolism,

$$\Psi_{BA} = B * A \quad (4)$$

where B and A are temporal sequences and Ψ_{BA} is their convolution product. In the "recall" we form the cross-correlation of the sequence A' with Ψ_{BA} :

$$F(t) = \int A'(\xi) \Psi_{BA}(\xi + t) d\xi. \quad (5)$$

Thus the Gabor's "recall function" becomes

$$F(t) = \int B(t - \eta) d\eta \int A(x + \eta) A'(x) dx \quad (6)$$

that is, in the symbolic formalism;

$$F = A' \otimes (B * A) = B * (A' \otimes A). \quad (7)$$

If $A' \otimes A \simeq \delta$ (A is a noise-like function) we obtain $F(t) \simeq B(t)$ (recall). If $A' \otimes A \neq \delta$ (A is not a noise-like function or A' is not a fragment of A), we obtain a filtering operation formally identical to the optical holographic compensation and synthesis pro-

cesses that have been developed in the spatial domain (Stroke, 1969).

A very interesting task, Gabor suggested, is to look for evidence of nervous structures capable to perform this scheme of operations. Processes such as those Gabor described may be actually present in the nervous system, but no evidence supported the hypothesis of their existence.

Now, we are perhaps able to acknowledge the validity of Gabor's suggestion. As a matter of fact we can rewrite Eq. (1), disregarding the physical model, as

$$R(\Delta t) = \int d\xi \int d\gamma [W_{DF}(\gamma + \xi) W_{DH}(\xi) - W_{DH}(\gamma + \xi) W_{DF}(\xi)] \Phi_{GG}(\gamma - \Delta t) \quad (8)$$

where $\gamma = \eta - \xi$.

Defining

$$W(\gamma) = \int [W_{DF}(\gamma + \xi) W_{DH}(\xi) - W_{DH}(\gamma + \xi) W_{DF}(\xi)] d\xi \quad (9)$$

we obtain

$$R(\Delta t) = \int W(\gamma) \Phi_{GG}(\Delta t - \gamma) d\gamma = W * (G \otimes G) \quad (10)$$

because Φ_{GG} is an even function. If we write Eq. (6) for $A = A'$ as

$$F(t) = \int B(t_1) \Psi_{AA}(t - t_1) dt_1 = B * (A \otimes A) \quad (11)$$

the formal identity between Reichardt's and Gabor's models turns out clearly.

This identity enhances, through behavioural experiments, the hypothesis of nervous holography-like processes (Van Heerden, 1970; Westlake, 1970). At least it shows that the sequence of operations required by the holographic or holophonic models of temporal memory (Longuet-Higgins, 1968; Gabor, 1968a, b; Watson, 1971), is actually carried out by a nervous system in the optomotor responses. This statement seems thus to suggest the existence of nervous structures with functional holographic properties and gives strength to Greguss' hypothesis that biographic principle is not restricted to the echolocating activity (Greguss, 1968).

In this respect it is appropriate to notice that Reichardt's model is in biology the only one able to describe the functioning of a complex nervous structure with great accuracy and in a formalized language. That is why the holographic analogy appears to be a quite interesting one. Fig. 2 is then a formal comparison between optomotor model and a holophonic memory device. Though there are possible different schemes of holographic memory, let us carry out the analogy outlined in Fig. 2.

The holophonic scheme of Fig. 2 stores first the "key" f with the signal W ; afterwards it will recall the time function W , when excited by a fragment of f , if the sequence is noise-like. On the other hand the light-flux fluctuation, which in the optomotor theory characterizes the insect's panorama, can be regarded as the key signal. Moreover it turns out that the physiological environment of the insect, by means of its movement, generates a light-flux function which is properly noise-like. Therefore the movement perception of the natural surroundings recalls the filter function W which may well represent some genetic built-in memory. Thus this formal comparison enables us to

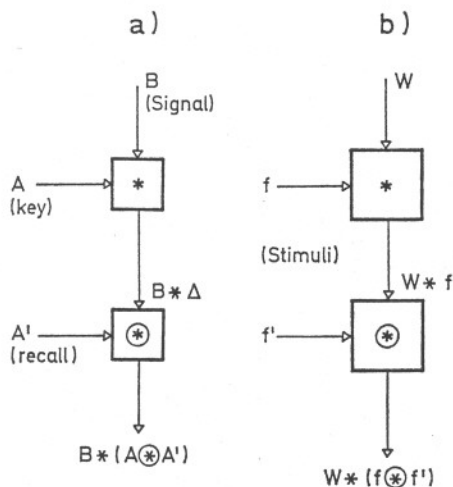

Fig. 2. Holographic (a) and optomotor (b) formal schemes

think at the optomotor network as a kind of short-term holophon-like memory.

Anyway it is to be emphasized that the meaning of the holographic aspect of the optomotor responses doesn't lay on the property of distributedness, perhaps the most important for the hypothesis of holographic mechanism within the brain (Westlake, 1970). For this reason it seems to us that the suggestion of neural holographic processes (Longuet-Higgins, Van Heerden, Westlake) appears overall meaningful because of its mathematical structure more than because of its physical mechanism. For instance the same mathematical holographic framework is able to underlie the optomotor behaviour as well as some general processes of filtering, compensation and associative recall (Stroke, 1969).

Therefore the same principles may operate at the peripheric and the central levels of nervous system. According to this point of view the formal identity between Gabor's and Reichardt's models essentially suggests that the characteristic sequence of filtering and correlation may be fundamental to neural processes.

All the "physical" holographic implications—distributed coding and wavelike mechanisms (Van Heerden, Westlake)—are not confirmed, and they would require of course more direct evidences.

In conclusion we have shown so far that the same general formalism underlies both the optomotor theory

and the holophon model of temporal memory, suggesting deeper neural analogies. As a consequence the experimental investigation of optical data processing in the insect's nervous system will perhaps provide also a ground for the analysis of pattern recognition and memory.

Acknowledgments. One of us (T.P.) wants to thank the European Molecular Biology Organization (EMBO) for a short term fellowship allowing him to visit the Max-Planck-Institut für Biologische Kybernetik, Tübingen. Helpful discussions he had in this occasion with Prof. Reichardt and his coworkers are gratefully acknowledged.

References

- Braitenberg, V.: Patterns of projection in the visual system of the fly. I. Retina-Lamina projections. *Exp. Brain Res.* **3**, 271 (1967).
- Gabor, D.: Holographic model of temporal recall. *Nature (Lond.)* **217**, 584 (1968a).
- Improved holographic model of temporal recall. *Nature (Lond.)* **217**, 1288 (1968b).
- Associative holographic memories. *IBM J. Res. Devel.* **13**, 2 (1969).
- Götz, K. G.: Flight control in *Drosophila* by visual perception of motion. *Kybernetik* **4**, 6, 199 (1968).
- Greguss, P.: Biography, a new model of information processing. *Nature (Lond.)* **219**, 482 (1968).
- Heerden, P. J., van: Models for the brain. *Nature (Lond.)* **225**, 177 (1970).
- Kirschfeld, K.: Die Projection der optischen Umwelt auf das Raster der Rhabdomere im Komplexauge von *Musca*. *Exp. Brain Res.* **3**, 248 (1967).
- Personal communication (May 1971).
- Longuet-Higgins, H. C.: Holographic model of temporal recall. *Nature (Lond.)* **217**, 104 (1968).
- Reichardt, W.: Autokorrelationsauswertung als Funktionsprinzip des Zentralnervensystems. *Z. Naturforsch.* **12b**, 448 (1957).
- Movement perception in insects. Processing of optical data by organisms and machines. Proceedings of the international School of Physics E. Fermi, Course XLIII (ed. W. Reichardt). New York: Acad. Press 1969.
- Strausfeld, N. J., Braitenberg, V.: The compound eye of the fly (*Musca domestica*): Connections between the cartridges of the Lamina Ganglionaris. *Z. vergl. Physiol.* **70**, 95 (1970).
- Stroke, G. W.: Principles of holography. New York: Wiley 1969.
- Watson, C. J. H.: Plasma echo and spin echo holophones. *Nature (Lond.)* **229**, 28 (1971).
- Westlake, P. R.: The possibilities of neural holographic processes within the brain. *Kybernetik*, **7**, 129 (1970).

Prof. A. Borsellino
Università di Genova
Istituto di Fisica
Viale Benedetto XV, 5
Genova/Italy