

How to measure turbulence with hot-wire anemometers

- a practical guide



Finn E. Jørgensen - 2002

Publication no.: 9040U6151. Date 2002-02-01.
© Dantec Dynamics A/S, P.O. Box 121, Tonsbakken 16-18, DK-2740 Skovlunde, Denmark.
All rights reserved.

INTRODUCTION

Turbulence is an important process in most fluid flows and contributes significantly to the transport of momentum, heat and mass. Turbulence also plays a role in the generation of fluid friction losses and fluid induced noise. In order to understand the behaviour of fluid flows and in order to design and evaluate vehicles, engines, pumps etc. the study of turbulence is therefore essential. Such studies are carried out by means of suitable instrumentation like hot-wire anemometers (often called CTA or constant temperature anemometers with reference to the operating principle) or laser-Doppler anemometers (LDA) and more recently with particle-imaging velocimetry (PIV). Measurements are often made as supplement to computer modelling (CFD, computational fluid dynamics).

The CTA anemometer works on the basis of convective heat transfer from a heated sensor to the surrounding fluid, the heat transfer being primarily related to the fluid velocity. By using very fine wire sensors placed in the fluid and electronics with servo-loop technique, it is possible to measure velocity fluctuations of fine scales and of high frequencies. The advantages of the CTA over other flow measuring principles are ease-of-use, the output is an analogue voltage, which means that no information is lost, and very high temporal resolution, which makes the CTA ideal for measuring spectra. And finally the CTA is more affordable than LDA or PIV systems.

The booklet is intended to give the reader what he needs to know in order to select and set up a CTA system and to perform measurements of basic turbulent quantities. It goes through all the steps needed in order to carry out reliable measurements starting with a chapter on selection of equipment (anemometer, probes, A/D board etc.) followed by experiment planning, system configuration and installation, anemometer set-up, velocity and directional calibration, data acquisition and data reduction. The more knowledgeable reader may only read the text boxes, which are written as comprehensive step-by-step procedures, and skip the text in-between.

Disturbing effects that may influence CTA measurements are mentioned briefly, and finally an example on how to calculate the uncertainty of velocities measured with a CTA anemometer is given. The booklet has a short introduction on the basic theory of the CTA anemometer.

Two appendices give examples on how to set-up and acquire data with the Dantec Dynamics MiniCTA and StreamLine anemometers utilizing the Dantec Dynamics application software.

TABLE OF CONTENTS

1. SELECTING MEASUREMENT EQUIPMENT	6
1.1 Measuring chain.....	6
1.2 Probe selection.....	6
1.2.1 <i>Quick guide to probe selection</i>	7
1.2.2 <i>Sensor types</i>	8
1.2.3 <i>Sensor arrays</i>	9
1.3 CTA anemometer/signal conditioner.....	10
1.3.1 <i>Anemometer selection</i>	10
1.3.2 <i>Signal conditioner</i>	11
1.4 A/D board	11
1.5 Computer	12
1.6 CTA application software	12
1.7 Traverse system	13
1.8 Calibration system.....	13
2. PLANNING AN EXPERIMENT	14
3. EXPERIMENT STEP BY STEP PROCEDURE	15
4. SYSTEM CONFIGURATION	16
4.1 Probe mounting and cabling.....	16
4.1.1 <i>Probe mounting and orientation</i>	16
4.1.2 <i>Cabling</i>	17
4.1.3 <i>Liquid grounding</i>	17
4.2 CTA configuration	18
4.2.1 <i>CTA bridge</i>	18
4.2.2 <i>Connecting CTA output to A/D board input channels</i>	18
4.3 Traverse system	19
5. ANEMOMETER SET-UP	19
5.1 CTA hardware set-up	19
5.1.1 <i>Overheat adjustment</i>	19
5.1.2 <i>How to use overheat adjustment</i>	20
5.1.3 <i>Square wave test</i>	21
5.2 Signal conditioner set-up	22
5.2.1 <i>Low-pass filtering</i>	22
5.2.2 <i>High-pass filtering</i>	22
5.2.3 <i>Applying DC-offset and gain</i>	23
6. VELOCITY CALIBRATION, CURVE FITTING	24
7. DIRECTIONAL CALIBRATION	26
7.1.1 <i>X-array probes</i>	26
7.1.2 <i>Tri-axial probes</i>	27
8. DATA CONVERSION	28
8.1.1 <i>Re-scaling</i>	28
8.1.2 <i>Temperature correction</i>	29
8.1.3 <i>Conversion into calibration velocities (linearisation)</i>	29
8.1.4 <i>X-probe decomposition into velocity components U and V</i>	30
8.1.5 <i>Tri-axial probe decomposition into velocity components U, V and W</i>	31

9. DATA ACQUISITION	32
10. DATA ANALYSIS	33
10.1 Amplitude domain data analysis	33
10.2 Time-domain data analysis.....	35
10.3 Spectral-domain data analysis.....	35
11. RUNNING AN EXPERIMENT	36
11.1 General procedure	36
11.2 Experimental procedure in non-isothermal flows.....	37
12. DISTURBING EFFECTS	38
12.1 Flow related effects	38
12.1.1 <i>Temperature</i>	38
12.1.2 <i>Pressure</i>	38
12.1.3 <i>Composition</i>	39
12.2 Sensor conditions	39
12.2.1 <i>Contamination</i>	39
12.2.2 <i>Sensor robustness</i>	39
12.2.3 <i>Sensor orientation</i>	39
13. UNCERTAINTY OF CTA MEASUREMENTS	40
13.1 Uncertainty of a velocity sample	40
13.1.1 <i>Anemometer</i>	40
13.1.2 <i>Calibration/conversion</i>	41
13.1.3 <i>Data acquisition related uncertainties</i>	41
13.1.4 <i>Uncertainties related to experimental conditions</i>	42
13.1.5 <i>Velocity sample uncertainty</i>	43
13.2 Uncertainty of reduced data.....	44
14. ADVANCED TOPICS	44
15. THE CTA ANEMOMETER, BASIC PRINCIPLES	46
15.1 Characteristics of the hot-wire sensing element.....	46
15.1.1 <i>Static characteristics - stationary heat transfer</i>	46
15.1.2 <i>Dynamic characteristics, frequency limit</i>	46
15.2 Mechanical design of hot-wire probes	48
15.3 Spatial resolution of hot-wires	48
15.4 Directional sensitivity of hot-wires.....	48
15.5 The constant temperature anemometer.....	50
16. REFERENCES	52

1. SELECTING MEASUREMENT EQUIPMENT

1.1 Measuring chain

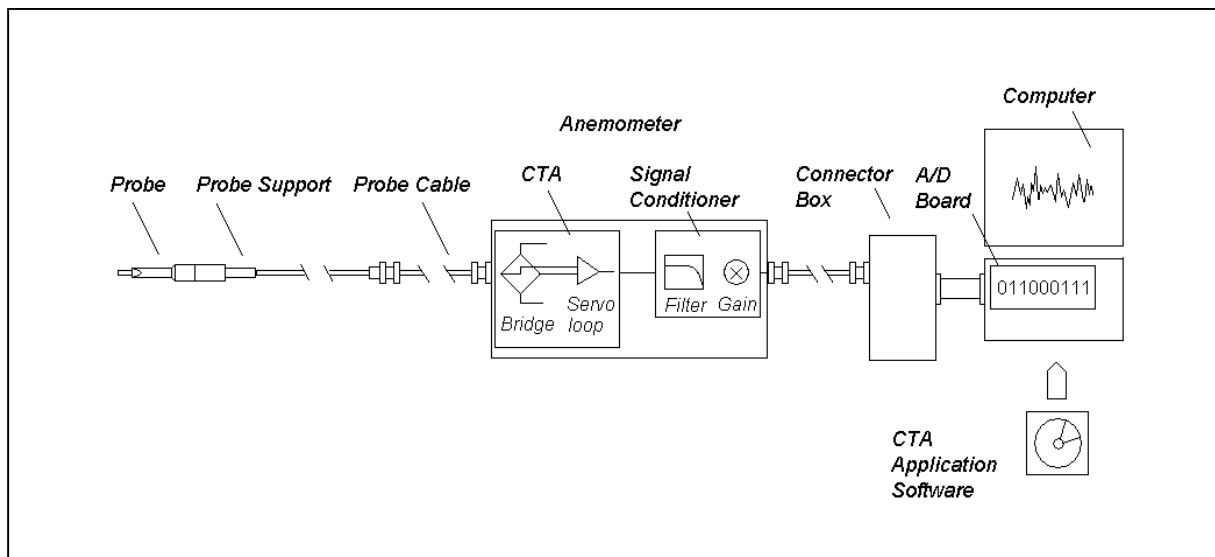

Fig. 1. Typical CTA measuring chain.

The measuring equipment constitutes a measuring chain. It consists typically of a *Probe* with *Probe support* and *Cabling*, a *CTA anemometer*, a *Signal Conditioner*, an *A/D Converter*, and a *Computer*. Very often a dedicated *Application software* for CTA set-up, data acquisition and data analysis is part of the CTA anemometer. A traverse system may be added for probe traverse, when profiles have to be investigated. A dedicated probe calibrator may speed up an experiment and reduce the total costs, as it cuts down expensive wind-tunnel time.

1.2 Probe selection

Probes are primarily selected on basis of:

- Fluid medium
- Number of velocity components to be measured (1-, 2- or 3)
- Expected velocity range
- Quantity to be measured (velocity, wall shear stress etc.)
- Required spatial resolution
- Turbulence intensity and fluctuation frequency in the flow
- Temperature variations
- Contamination risk
- Available space around the measuring point (free flow, boundary layer flows, confined flows).

1.2.1 Quick guide to probe selection

Free and Confined Flows		
Type of flow	Medium	Recommended Probes
1-Dimensional		
Uni-directional	Gas	Single sensor Wire Single sensor Fiber, thin coat. Wedge-shaped Film, thin coat. Conical Film, thin coat.
	Liquid	Single sensor Fiber, heavy coat. Wedge-shaped Film, heavy coat. Conical Film, heavy coat.
Bi-directional	Gas	Split-fibers, thin coat.
	Liquid	Split-fibers, heavy coat.
2-Dimensional		
One Quadrant	Gas	X-array Wires X-array Fibers, thin coat. V-wedge Film, thin coat.
	Liquids	X-array Fibers, heavy coat. V-wedge Film, heavy coat.
Half Plane	Gas	Split-fibers, thin coat.
	Liquids	Split-fibers, heavy coat.
Full Plane	Gas	Triple-split Fibers, thin coat. X-array Wire, flying hot-wire
	Liquids	Triple-split Fibers, <i>special</i>
3-Dimensional		
One Octant (70° Cone)	Gas	Tri-axial Wire Tri-axial Fiber, thin coat.
	Liquids	Tri-axial Fiber, <i>Special</i>
90° Cone	Gas	Slanted Wire, rotated probe
	Liquids	Slanted Fiber, heavy coat.
Full Space	Gas	Omnidirectional Film
Wall Flows (Shear Stress)		
Type of flow	Medium	Recommended Probes
1-Dimensional		
Unidirectional	Gas	Flush-mounting Film, thin coat. Glue-on Film, thin coat.
	Liquids	Flush-mounting Film, heavy coat. Glue-on Film, <i>special</i>

1.2.2 Sensor types

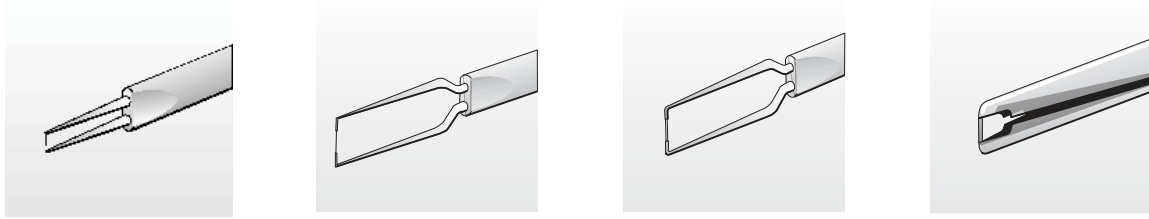

Anemometer probes are available with four types of sensors: Miniature wires, Gold-plated wires, Fibre-film or Film-sensors. Wires are normally 5 μm in diameter and 1.2 mm long suspended between two needle-shaped prongs. Gold-plated wires have the same active length but are copper- and gold-plated at the ends to a total length of 3 mm long in order to minimise prong interference. Fibre-sensors are quartz-fibers, normally 70 μm in diameter and with 1.2 mm active length, covered by a nickel thin-film, which again is protected by a quartz coating. Fibre-sensors are mounted on prongs in the same arrays as are wires. Film sensors consist of nickel thin-films deposited on the tip of aerodynamically shaped bodies, wedges or cones.

Sensor type selection:

Wire sensors:

Miniature wires:

First choice for applications in air flows with turbulence intensities up to 5-10%. They have the highest frequency response. They can be repaired and are the most affordable sensor type.

Gold-plated wires:

For applications in air flows with turbulence intensities up to 20-25%. Frequency response is inferior to miniature wires. They can be repaired.

Fibre-film sensors:

Thin-quartz coating:

For applications in air. Frequency response is inferior to wires. They are more rugged than wire sensors and can be used in less clean air. They can be repaired.

Heavy-quartz coating:

For applications in water. They can be repaired.

Film-sensors:

Thin-quartz coating:

For applications in air at moderate-to-low fluctuation frequencies. They are the most rugged CTA probe type and can be used in less clean air than fibre-sensors. They normally cannot be repaired.

Heavy-quartz coating:

For applications in water. They are more rugged than fibre-sensors. They cannot normally be repaired.

Note: Wire probes and fibre-film probes with thin quartz coating can be used in non-conducting liquids.

1.2.3 Sensor arrays

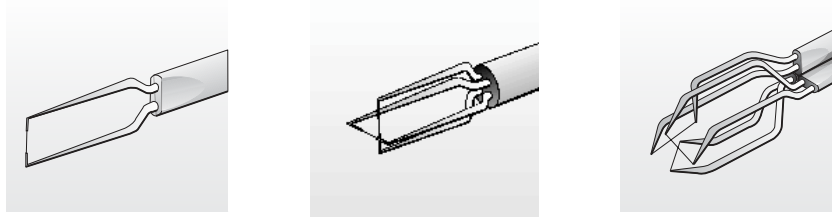

Probes are available in one-, two- and three-dimensional versions as single-, dual and triple-sensor probes referring to the number of sensors. Since the sensors (wires or fibre-films) respond to both magnitude and direction of the velocity vector, information about both can be obtained, only when two or more sensors are placed under different angles to the flow vector.

Split-fibre and triple-split fibre probes are special designs, where two or three thin-film sensors are placed in parallel on the surface of a quartz cylinder. They may supplement X-probes in two-dimensional flows, when the flow vector exceeds an angle of $\pm 45^\circ$. They are not supported by commercially available CTA software.

Sensor array selection:

Single-sensor normal probes:

For one-dimensional, uni-directional flows. They are available with different prong geometry, which allows the probe to be mounted correctly with the sensor perpendicular and prongs parallel with the flow.

Single-sensor slanted probes (45° between sensor and probe axis):

For three-dimensional stationary flows where the velocity vector stays within a cone of 90° . Spatial resolution $0.8 \times 0.8 \times 0.8$ mm (standard probe). Must be rotated during measurement.

Dual-sensor probes:

X-probes:

For two-dimensional flows, where the velocity vector stays within $\pm 45^\circ$ with respect to the probe axis.

Split-fibre probes:

For two-dimensional flows, where the velocity vector stays within $\pm 90^\circ$ with respect to the probe axis. The cross-wise spatial resolution is 0.2 mm, which makes them better than X-probes in shear layers.

Triple-sensor probes:

Tri-axial probes:

For two-dimensional flows, where the velocity vector stays inside a cone of 70° opening angle around the probe axis, corresponding to a turbulence intensity of 15%. The spatial resolution is defined by a sphere of 1.3 mm diameter.

Triple-split film probes:

For fully reversing two-dimensional flows, Acceptance angle is $\pm 180^\circ$.

Note: Split-fiber probes and triple-split film probes are not supported by standard application software packages.

1.3 CTA Anemometer/Signal conditioner

1.3.1 Anemometer selection

Often a CTA anemometer is on hand for an experiment, while it is more seldom that selecting and purchasing an anemometer is part of the experimental planning. In both cases, however, it is important to make sure that the anemometer to be used has the required bandwidth and sufficiently low noise and drift to provide stable and reliable results. In water applications it is also important to check that the CTA bridge can deliver sufficient power to operate the probe at the expected flow velocity.

CTA anemometer and bridge selection:

Research type CTA (StreamLine):

Bandwidth is typically 100-250 kHz, max. 400 kHz.

Noise contributes typically with 0.005% to a background turbulence of 0.1% of 10 kHz bandwidth.

Drift typically 0.5 μV per $^{\circ}\text{C}$ (amplifier input).

CTA bridges:

1:20 General purpose bridge for air applications at bandwidths below approx. 250 kHz.

1:20 General purpose bridge with high power for water applications.

1:1 Symmetrical bridge for bandwidths up to 400 kHz, or for long probe cables up to 100 m (reduces max. bandwidths to typically 50 kHz).

Set-up:

Automatic set-up of and operation of CTA bridge via application software.

Dedicated type CTA (MiniCTA):

Bandwidth is typically 10 kHz.

Noise on output signal is typically 1-2 mV.

Drift typically 1 μV per $^{\circ}\text{C}$ (amplifier input)..

CTA bridges:

1:20 General purpose bridge for air applications at a bandwidth up to approx. 10 kHz.

Set-up:

Manual set-up and operation of CTA bridge.

Research type anemometers are normally multi-channel systems with up to 6 or more CTA channels. They have built-in Signal conditioners for amplification and filtering of the CTA signal before A/D conversion.

Dedicated anemometers are single-channel instruments supporting only one sensor. They do normally only have a low-pass filter for the output signal. They can be combined for multi-point measurements.

1.3.2 Signal conditioner

Most CTA anemometers have built-in *Signal Conditioners* for *high-pass* and *low-pass filtering* and for *amplification* of the CTA signal.

Signal conditioner selection:

Offset:

Should ideally cover the input range of the A/D board. In practice, however, it suffices to cover the expected range of the CTA output signal, e.g. 0-5 Volts.

Gain:

Improves A/D board resolution. A gain of 16 gives a 12-bit A/D board the same resolution as a 16-bit board.

High-pass filter:

Removes the DC-part of the signal. Is only needed, when low frequency fluctuations have to be removed from the signal prior to spectral analysis.

Low pass filter:

Removes electronic noise from the signal and prevents folding back of spectra (aliasing). The filter should be as steep as possible. Research anemometers normally have a -60 dB/decade roll-off, while dedicated simpler anemometers may have -20 dB/decade.

1.4 A/D board

The CTA signal is acquired via an A/D converter board and saved as data-series in a computer.

Selecting the A/D board:

Number of channels:

Shall as a minimum equal the number of CTA channels plus additional channels (e.g. temperature) needed in the experiment.

Input range:

Shall cover as a minimum the CTA voltage range. A 0-10 Volts range is well suited for most anemometers and applications.

Input resolution:

Shall be sufficient to provide the required resolution in converted data. A 12-bit board typically gives a velocity resolution of 0.1 to 0.2%.

Sampling rate SR:

Shall be minimum two times the maximum frequency in the flow: $SR=2 \cdot f_{max}$

SR is reduced by the number of channels, n , in use: $SR(n)=1/n \cdot 2 \cdot f_{max}$

A 100 kHz board covers most low-to-medium velocity applications (<100 m/s).

Simultaneous sampling:

May be needed when correlation between fast sampled multiple channels (e.g. Reynolds shear stress) is required.

Check the sampling rate per channel, as it may be significantly reduced due to delays on the board as compared with the sampling rate for consecutively sampled signals with the same board.

External triggering:

Needed to start the data acquisition by an event related to the flow.

1.5 Computer

The choice of computer to be used for CTA measurements is normally not critical. Speed and memory storage are normally more than sufficient for most applications. It is, however, important to ensure that the CTA controller, the A/D board driver and the traverse driver are compatible, i.e. runs under the same operative system and can be called from the same application software. Also that the required number of com ports for communication with the CTA anemometer and the traverse system is available.

1.6 CTA application software

Commercially available CTA anemometers are normally delivered together with an application software. Advanced software packages control the anemometer and carry out automatic set-up of both CTA bridge and signal conditioner [14]. They also perform automatic velocity and directional calibrations and they can be programmed to perform automatic experiments with probe traversing and data acquisition. Finally data are converted into engineering units and reduced to relevant statistical quantities: moments, spectra etc. Application software for manually operated anemometers is also available. Except for the anemometer and calibrator drivers, they have by and large the same functionality as the advanced packages.

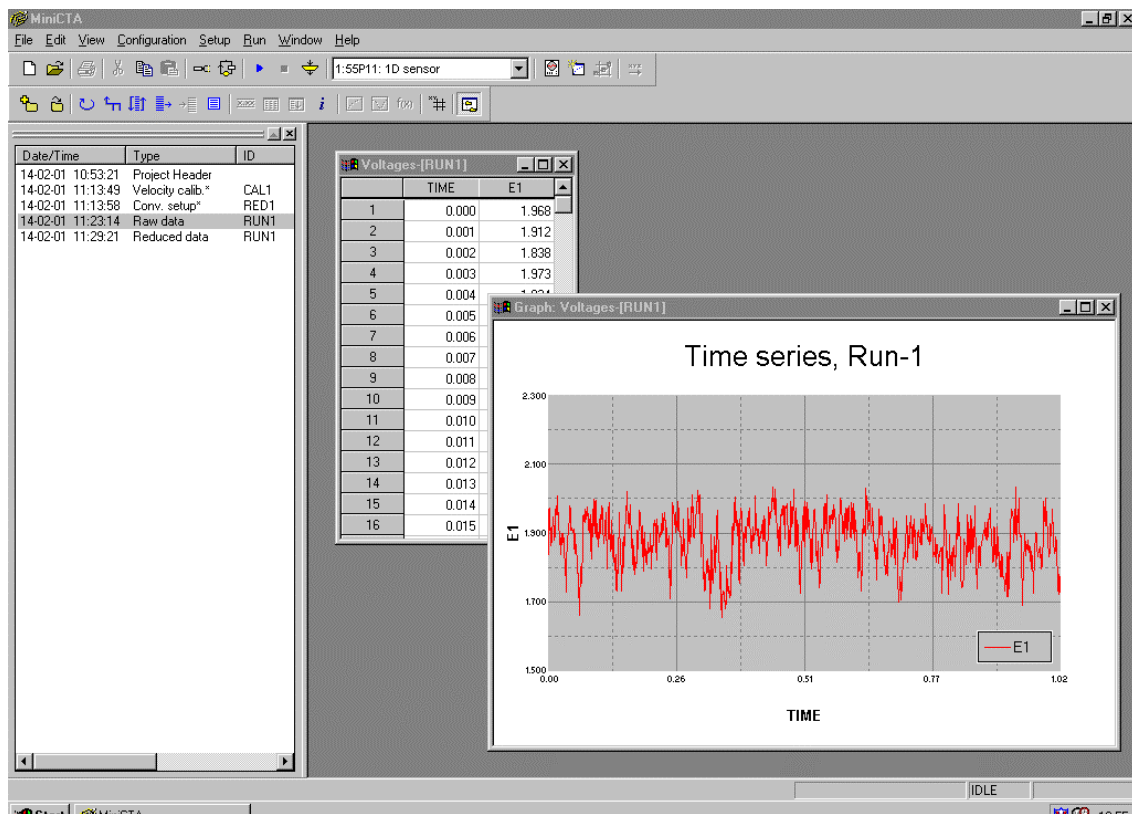

Note: It is highly recommended to use professional CTA application software when at all possible in order to reduce the time and costs it otherwise takes to start up. In special cases, where the CTA is part of a large measurement system with input from many other types of instruments including the control of windtunnels and traverses, it may be worthwhile considering writing ones own software. Even then, it may be sensible to use the velocity and directional calibration routines offered by a professional application software.

1.7 Traverse system

A traverse system is needed, if probe movement is part of the experimental procedure. It may have up to three axis and a rotation unit, if used for slanting probes.

Traverse selection:

Axis:

Number and range of traverse axis shall fit to the experiment.

Resolution:

Linear resolution shall be sufficient. Commercially available traverses for CTA probes normally have a resolution better than 0.01 mm and can be repositioned within approx. ± 0.1 mm.

Control:

Automatic traverse is most conveniently controlled from the CTA application software.

Impact on flow pattern:

The traverse should not disturb the flow at the probe position. This may be achieved by using aerodynamically shaped probe mounts on the traverse.

The traverse should be rigid so that the parts exposed to the wind load do not vibrate or bend. Such vibrations or bending will bias the velocity measurement.

1.8 Calibration system

A calibration system is normally not considered part of the measuring chain. It plays, however, an important role for the accuracy and the speed, with which an experiment can be carried out. Calibrations may be performed in a dedicated calibrator with a low-turbulent free jet, whose velocity is calculated on basis of the pressure drop over its exit. Calibrations can also be performed in the wind-tunnel, where the experiments are going to take place, with a pitot-static tube as the velocity reference.

Calibration facility:

Dedicated probe calibrator:

Velocity range: From a few cm/s to several 100 m/s.

Accuracy: Typically $\pm 0.5\%$ of reading above 5 m/s.

Additional features: May be used for directional calibration of multi-sensor probes.

Wind-tunnel with Pitot-static tube:

Velocity range: From approx. 2 m/s to typically 50 m/s.

Accuracy: Typically $\pm 1\%$ of reading above 5 m/s. Depends on pressure device and decreases at low velocities.

2. PLANNING AN EXPERIMENT

The quality of fluid dynamic measurements and the efficiency of the experimental procedure very much depends on the selection of the equipment, inclusive the application software, and on the planning of the experiment. Qualified decisions depend on the capability to identify the measurable quantities and to select the data analyses needed to provide the required results.

What to do:	Check list:
<p><i>Know</i> what you want to measure, the physical variable, the statistical functions, the ultimate presentation.</p> <p><i>Know</i> your sensor: sensitivity limitations, potential problems.</p> <p><i>Know</i> the results beforehand. If you do not guess, cross check, explore.</p> <p><i>Design</i> the measurement.</p> <p><i>Estimate</i> optimum data rate, measurement time, number of samples needed.</p> <p><i>Check</i> the function of equipment by varying parameters. Is the system immune to small changes in bandwidth, range, gain</p> <p><i>Monitor</i> the results online – things may change: temperature, conditions during a traverse.</p> <p>Do not leave and go for coffee!</p>	<p><i>Define</i> quantities to be measured:</p> <ul style="list-style-type: none"> - Higher order moments (mean, standard deviation, turbulence, shear stress, etc.). - Frequency distribution (spectra) - Eddy sizes (length scales) <p><i>Define</i> distribution of measuring points:</p> <ul style="list-style-type: none"> - Single point measurement - Profiles (probe traverse) - Simultaneously in many points <p><i>Select</i> Equipment and software on basis of:</p> <ul style="list-style-type: none"> - Flow medium: Gas or liquid. - Dimensions: 1-, 2- or 3-dimensional. - Fluctuations: Turbulence intensity, length scales, frequency distribution. - Temperature: Constant or varying. - Quantity to be measured: Velocity components, shear stress, temperature etc. <p><i>Define</i> Experiment procedure on basis of:</p> <ul style="list-style-type: none"> - Type of flow field: Free or internal flows, wake flow, boundary layer flow, reversing flow. - Point distribution: Single-point or distributed. - Data analysis: Amplitude-, time- or spectral domain <p><i>Define</i> Data analysis on the basis of:</p> <ul style="list-style-type: none"> - Required result versus measured quantity. - Equipment set-up and data conversion set-up

Note: Some of the characteristics, e.g. length scales and frequency distribution, may be unknown prior to an experiment and have to be measured before the final set-up of the experiment.

3. EXPERIMENT STEP BY STEP PROCEDURE

When the flow and parameters of interest are defined and the necessary hardware is installed and configured (*Chapter 1 and 2*), the experimental procedure consists of the following steps (numbers in bracket refer to relevant chapters):

HARDWARE SET-UP:

1. Adjust overheat ratio (*5.1.1*).
2. Measure ambient reference temperature, if temperature variations are expected.
3. If need be, check system response with square wave test (*5.1.2*).
4. Set low-pass filter in Signal Conditioner (*5.2.1*).

VELOCITY CALIBRATION:

5. Expose the probe to a set of known velocities and determine the transfer function (*6*).

DIRECTIONAL CALIBRATION:

6. Only for 2- and 3-D probes, and only if high accuracy is required. Otherwise use manufacturer's defaults for yaw and pitch coefficients (*7*).

CONVERSION AND DATA REDUCTION:

7. Transfer function provides calibration velocities (*8.1.1-8.1.2-8.1.3*).
8. Decomposition using yaw and pitch coefficients provides velocity components (*8.1.4 - 8.1.5*).
9. Data analysis module provides reduced data. (*10*).

DEFINE EXPERIMENT:

10. Select hardware set-up
Option 1: Adjust overheat ratio if temperature changes are expected (*11.2*).
Option 2: Leave overheat resistor constant (requires temperature correction of data, if temperature changes (*11.2*)).
11. Probe movement: Define traverse grid (for measurements in many points)

DEFINE DATA ACQUISITION:

12. Sampling frequency and number of samples (*9*).

TEST RUN:

13. Place the probe in the flow and acquire data. Check that reduced data (mean velocity, standard deviation etc.) are as expected.

RUN EXPERIMENT:

14. Move the probe to position, readjust hardware, if need be, and acquire probe voltages (*11*).

CONVERT AND REDUCE DATA:

15. Load the data and apply the selected conversion/reduction routine (*10*).

PRESENTATION OF DATA:

16. Present data in graphs or export them to a report generator.

4. SYSTEM CONFIGURATION

System configuration is the process of mounting and interconnecting the selected probes, cables, CTA anemometers, signal conditioners and A/D channels. The configuration may also include a Traverse system for the probe.

4.1 Probe mounting and cabling

4.1.1 Probe mounting and orientation

The probe is mounted in the flow with the same orientation as it had during calibration. Preferably with the wire perpendicular to the flow and the prongs parallel with the flow.

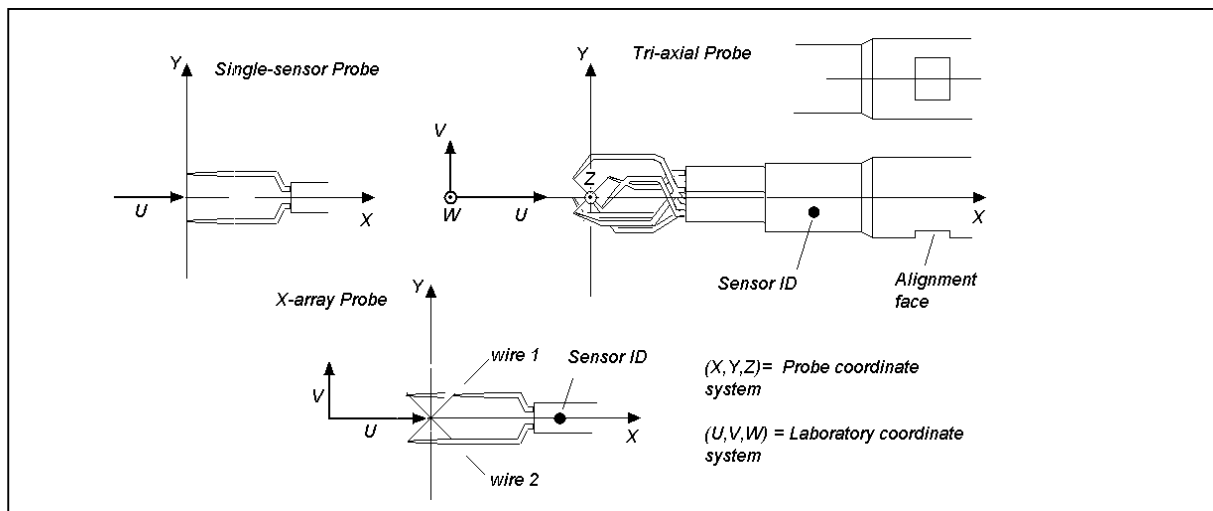

Fig. 2. Probe orientation with respect to laboratory coordinate system.

Straight probes are mounted with the probe axis parallel with the dominant velocity direction. It is recommended that the probe coordinate system (X, Y, Z) coincides with the laboratory coordinate system (U, V, W) .

The probe is mounted in a probe support, which is equipped with a cable and BNC connector, one for each sensor on the probe. Film probes are equipped with fixed cables and need no supports. Probe bodies and the probe support are designed so that their outer surfaces are electrically insulated from the electrical circuitry of the probe or anemometer circuit. They can therefore be mounted directly to any metal part of the test rig without the risk of ground loops.

*It is important to note that the BNC connectors **do not** make electrical contact with any metal parts of the rig or elsewhere. The BNC connectors represent the signal ground and may therefore carry ground loops. It is also important that the BNC connectors on dual- or triple-sensor supports do not touch each other, as it will influence the floating amplifiers in the CTA.*

It is therefore recommended to cover all BNC connectors with a length of plastic tube.

Important: The probe should only be mounted in its support or removed from it, when the CTA is switched to Stand-by or the power to the CTA is disconnected.

4.1.2 Cabling

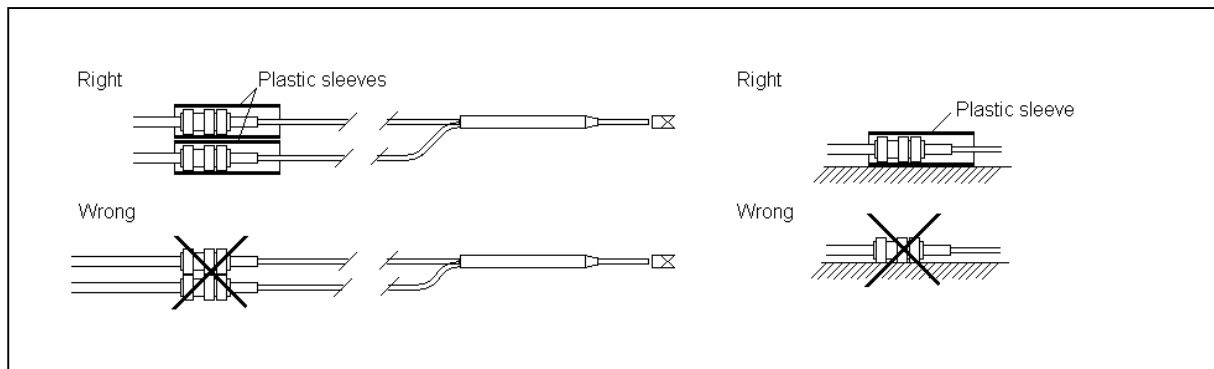

Fig. 3. Avoiding ground loops and noise pickup.

The distance between the probe and the CTA should be kept as small as possible. The standard cable length is 4 meters probe cable plus 1 meter support cable, and this combination should be used if at all possible in order to obtain maximum bandwidth and in order to avoid picking up more noise than need be. If longer cables are necessary, it is important to follow the lengths recommended by the manufacturer for the actual CTA bridge (normally 20 or 100 m).

*It is recommended to use the BNC-BNC cables delivered together with the CTA by the manufacturer in order to match the cable-compensating network in the bridge.
If this is not done, the bridge may become unstable and deliver a useless oscillating voltage output or, in the worst case, burn the sensor.*

4.1.3 Liquid grounding

Film probes mounted in liquids may be damaged, if a voltage difference between the sensor film and the liquid builds up by electric charges in the flowing medium. If such charge build up occurs, the insulating quartz coating may break down and the thin-film will be etched away due to electrolysis. The liquid must therefore be grounded to the anemometer's signal ground as close to the probe as possible.

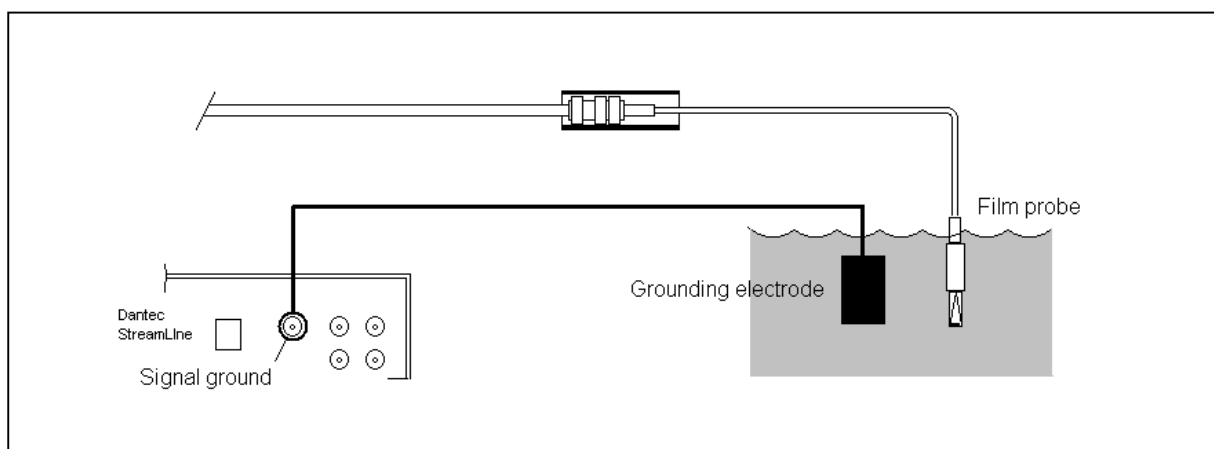

Fig. 4. Grounding of liquid to Signal ground near film probe.

4.2 CTA configuration

4.2.1 CTA bridge

The CTA bridge configuration is selected on the basis of the required *bandwidth*, the required *power* to the probe (related to fluid medium, velocity and probe type) and on basis of the *distance* between probe and the CTA.

CTA bridge configuration:

Standard CTA bridge:

Bridge ratio 1:20

Resistor in series with the probe: normally 20 ohms.

This bridge configuration can be used in the most applications.

Symmetrical CTA bridge (research type anemometers):

Bridge ratio 1:1

Resistor in series with the probe: normally 20 ohms.

This bridge is recommended for *very low turbulence intensities* (typically less than 0.1%) or *very high fluctuation frequencies* (typically above 200-300 kHz).

Or when *long cables* between probe and CTA are needed.

It has lower noise and can be balanced to a higher bandwidth than the 1:20 bridge.

High power CTA bridge (research type anemometers):

Bridge ratio 1:20

Resistor in series with the probe: 10 ohms.

Recommended for *high power* applications (water at high speeds, e.g. 1 m/s or above). Probe current is almost doubled (typically 0.8 amps. compared with 0.4-0.5 amps.)

4.2.2 Connecting CTA output to A/D board input channels

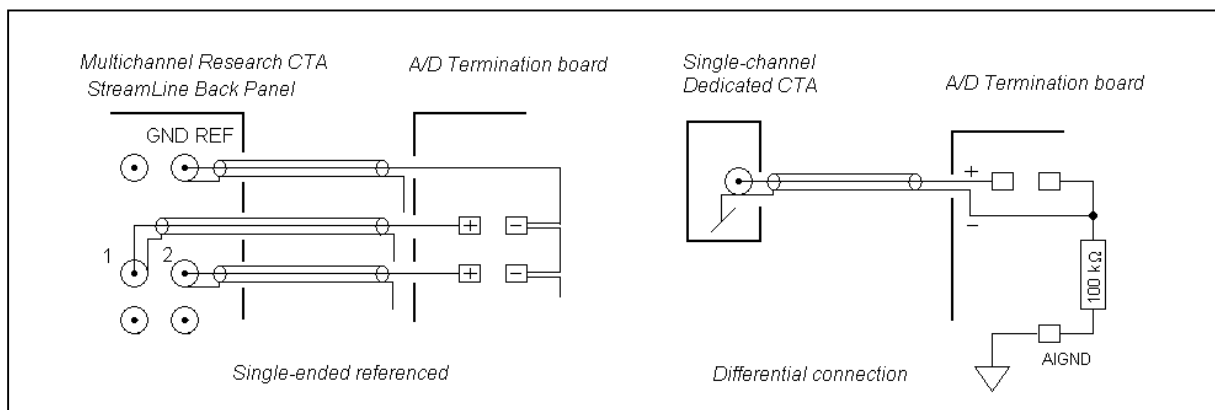

It is important to follow the manufacturer's instructions when connecting the CTA output to the A/D board input. Research anemometers where the CTA modules have separate power supplies and common signal ground may be connected single-ended referenced. Dedicated anemometers in separate housings should normally be connected differentially in order to avoid cross-talk between channels and each individual signal ground connected to the Analog Input ground of A/D board via a 100 k Ω resistor. The cable length between the CTA output and the A/D board input should be kept as short as possible, preferably a few meters. The configuration of the A/D board is done in the manufacturer's application software.

4.3 Traverse System

The Traverse system is used to move the probe around in the flow. It is selected on the basis of the *number of axis* to be traversed, the *size of the area* to be traversed, the *positioning accuracy* and the expected *forces from the flow* acting on the traverse.

When a PC controlled traverse system is selected, it is important to make sure that the moving of the traverse and the acquisition of data can be timed securely. The most practical solution is when the traverse can be moved from the CTA application software, i.e. the traverse is part of the hardware configuration, or when the CTA data can be acquired in the same software, which controls the traverse. The communication with the traverse is often done via a serial comport or via a GPIB interface.

5. ANEMOMETER SET-UP

The anemometer set-up consists of *CTA hardware set-up* and *Signal conditioner filter and gain adjustment*.

5.1 CTA hardware set-up

The hardware set-up consists of an *overheat adjustment* (static bridge balancing) and a *square wave test* (dynamic balancing). When a signal conditioner is part of the CTA, the hardware set-up also includes *low-pass filter* and optional *gain* settings.

5.1.1 Overheat adjustment

The overheat adjustment determines the working temperature of the sensor. The overheat resistor (decade resistor) in the right bridge arm is adjusted, so that the wanted sensor operating temperature is established when the bridge is set into *Operate*. The cold and warm resistors are related via the overheating ratio, a :

$$a = \frac{R_w - R_0}{R_0} \quad \text{where } R_w \text{ is the sensor resistance at operating temperature } T_w \text{ and } R_0 \text{ is}$$

its resistance at ambient (reference) temperature T_0 .

The over temperature $T_w - T_0$ can be calculated as:

$$T_w - T_0 = \frac{a}{\alpha_0} \quad \text{where } \alpha_0 \text{ is the sensor temperature coefficient of resistance at } T_0.$$

The probe leads resistance and the resistances of the support and cable are normally provided by the manufacturer and need therefore not to be measured separately, unless high accuracy in setting the over temperature is required.

Some dedicated CTA anemometers do not have facilities for measuring the probe cold resistance. In such cases it may suffice to use the resistance values stated on the probe container.

Overheat adjustment procedure:

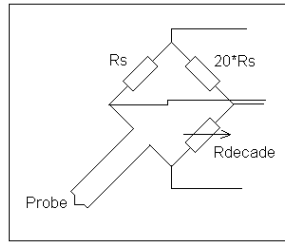
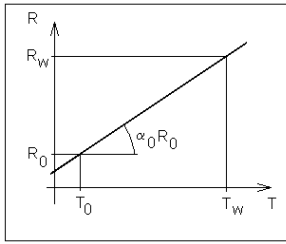

Measure the total resistance $R_{tot,0}$ at ambient temperature T_0 and calculate the active sensor resistance:

$$R_0 = R_{tot,0} - (R_{leads} + R_{sup\ port} + R_{cable})$$

R_{leads} = probe leads resistance, $R_{support}$ = support resistance and R_{cable} = cable resistance.

Select a suitable overheat ratio, a .

Recommended values are $a=0.8$ in air (over temperature approx. 220°C) and $a=0.1$ in water (over temperature approx. 30°C).

Calculate the decade resistance as:

$$R_{dec} = BR \cdot [(1 + a) \cdot R_0 + R_{leads} + R_{sup\ port} + R_{cable}]$$

BR = bridge ratio = 20 (in most CTA's)

Adjust the decade resistance to R_{dec} .

Note: If the probe resistance is measured with an ordinary ohm meter, it is recommended to check the measuring current. The current should not exceed 1 mA when measuring the resistance of a 5 μm wire probes in order to avoid heating the wire.

5.1.2 How to use overheat adjustment

The practical use of overheat adjustment depends on how the temperature varies during set-up, calibration and experiment.

The temperature is **constant** throughout (T varies less than for example $\pm 0.5^\circ\text{C}$):

The overheat is adjusted *once* at the start of the experiment and left untouched during calibration and data acquisition (“Automatic overheat adjust” is *disabled* in computer controlled anemometers).

The temperature **varies** from set-up to calibration and during the experiment. There are two options:

1. Overheat adjust. The probe resistance is measured, and the overheat is *readjusted* before calibration and before to each data acquisition. The overheat ratio will then be the same in all situations and the temperature influence minimised. (“Automatic overheat adjust” is *enabled* in computer controlled anemometers).

2. *Temperature correction:* The overheat is adjusted *once* and left untouched during calibration and data acquisition. The temperature is measured during calibration and during the experiment and used to correct the anemometer voltages before conversion and reduction.

See *Chapter 11.2*.

5.1.3 Square wave test

The square wave test, or dynamic bridge balancing, serves two purposes: It can be used to optimise the bandwidth of the combined sensor/anemometer circuit or simply to check that the servo-loop operates stable and with sufficiently high bandwidth in the specific application. It is carried out by applying a square wave signal to the bridge top. The time it takes for the bridge to get into balance is related to the time constant, and hence the bandwidth, of the system. Most CTA anemometers have built-in square-wave generators. If not, they normally have input for an external square wave generator.

Square wave test procedure:

Expose the probe to the expected maximum velocity.

Connect an oscilloscope to the CTA output, *if* the square wave is not displayed in the application software.

Apply the square wave to the bridge.

Correct square wave test, $U = 30$ m/s

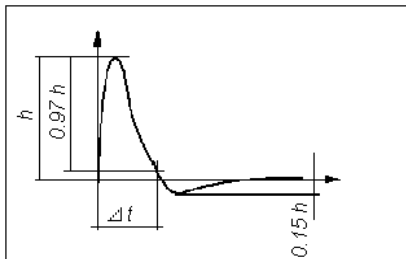

Too high gain

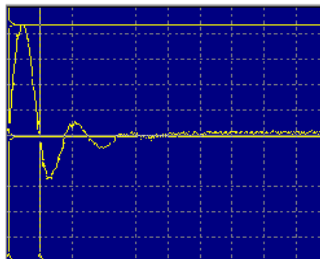

Too long cable (10 m instead of 5 m)

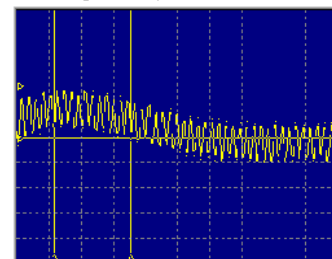

Adjust amplifier filter and gain until the response curve gets a 15% undershoot. The response should be smooth without “ringing” either at the top or at the zero line.

Determine Δt being the time it takes the servo-loop to regulate back to 3% of its maximum value with an undershoot of 15%.

Calculate the bandwidth of the probe/anemometer system (or cut-off frequency) f_c :

$$f_c = \frac{1}{1.3 \cdot \Delta t} \quad (\text{wire probes}) [10] \quad f_c = \frac{1}{\Delta t} \quad (\text{fibre-film probes}) [11]$$

The bandwidth is defined as the frequency, at which the fluctuation amplitude is damped by a factor 2 (–3 dB limit).

Note: For wire probes up to 100 m/s the amplitude damping starts at frequencies 0.3 - 0.5 times smaller than the –3 dB cut-off frequency determined by the square wave test.

The response can be optimised by adjusting the amplifier filter and gain. High gain setting gives high bandwidth, but also greater risk for the servo-loop to become unstable. It is therefore often recommended to reduce the gain in order to run safely.

Most CTA manufacturer's are recommending default settings for gain and filter, which can be used in most applications. Dedicated CTA anemometers often have fixed set-up for the servo-loop, which works within the bandwidth stated for them without further adjustment by the user.

5.2 Signal Conditioner set-up

The signal conditioner provides facilities for the filtering and the amplification of the CTA signal prior to digitizing by the A/D converter.

5.2.1 Low-pass filtering

Low-pass filtering is used in order to remove noise and to prevent higher frequencies from folding back (anti-aliasing). The setting of the low-pass filter relates to the highest frequency in the flow.

Low-pass filtering:

Estimate the highest frequency: f_{max} .

Select the cut-off, frequency: $f_{cut-off} = 2 \cdot f_{max}$

Select the filter setting closest to the cut-off frequency.

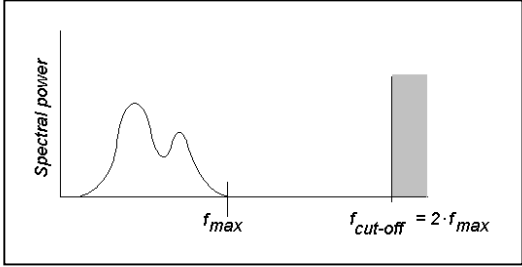

If low-pass filtering is not performed, the energy at frequencies lower than $f_{cut-off}$ will be contaminated by higher frequencies if the Nyquist sampling criteria is applied. This appears as a false energy peak in the power spectrum.

5.2.2 High-pass filtering

High-pass filtering is used to clean the signal, if FFT spectra calculation is required. When the CTA signal fluctuates on a timescale longer than the total length of the data record, it will give unwanted high frequency contributions in an FFT-based spectrum. Otherwise it should *not* be applied.

High-pass filtering:

Select the data record length, t_{record} .

Calculate the high-pass cut-off frequency: $f_{cut-off} = \frac{5}{2 \cdot t_{record}}$

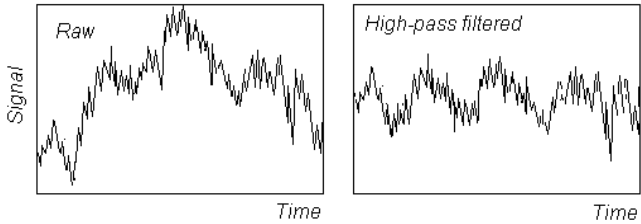

This eliminates waves with a wavelength larger than 2/5 of the record length. Shorter waves will not be interpreted as erroneous non-stationary contributions to the signal.

High-pass filtering will make the signal stationary. It should be noted that no spectral information is available below the cut-off frequency of a high-pass filter.

High-pass filters with a sharp and low cut-off frequency are difficult to establish and they very often have large phase lags. They should therefore be used with care. A better solution might be to perform digital filtering of the full data set with, for example, a sixth order filter.

5.2.3 Applying DC-offset and Gain

DC-offset:

The CTA signal level may be reduced by subtraction of a DC-offset voltage. This is necessary if the signal moves outside of the range of the A/D board, when a high amplification of the signal is needed prior to digitizing.

DC-offset procedure:

Determine the minimum value E_{min} of the CTA signal to be measured.

Adjust the DC-offset in the Signal conditioner to: $E_{offset} = E_{min}$

Note: Avoid applying DC-offset if possible, as the signal then no longer directly represents the power transferred from the sensor to the fluid. The usual temperature correction routines are therefore no longer valid, unless the signal is reconstructed by adding the DC-offset prior to correction.

Signal amplification (Gain)

The CTA signal may have to be amplified in order to utilise an A/D board with a resolution, that is too small for the application.

In most low to medium velocity applications with a turbulence intensity above 2% to 3%, a 12 bit A/D board is sufficient without the need for amplification of the CTA signal. A 12 bit A/D board has a resolution of 2.4 mVolts in the 0-10 Volts range. By applying a gain of 16 to the CTA signal prior to digitization the 12-bit resolution is improved to 0.15 mV corresponding to that of a 16 bit board with CTA gain 1. This is sufficient for measurement of background turbulence down to approximately 0.1%.

Gain setting procedure:

Determine the required velocity resolution ΔU in m/s.

Calculate the mean slope $\delta E / \delta U$ of the probe calibration curve in the velocity range of interest:

$$\frac{dE}{dU} = \frac{E(U_2) - E(U_1)}{U_2 - U_1} \quad \text{where } E(U) \text{ is the CTA voltage at the velocity } U.$$

Calculate the required voltage resolution: $\Delta E = \Delta U \cdot \frac{dE}{dU}$

Calculate the gain G as: $G = \frac{\Delta E_{AD}}{\Delta E}$ where ΔE_{AD} is the resolution of the A/D board.

6. VELOCITY CALIBRATION, CURVE FITTING

Calibration establishes a relation between the CTA output and the flow velocity. It is performed by exposing the probe to a set of known velocities, U , and then record the voltages, E . A curve fit through the points (E, U) represents the transfer function to be used when converting data records from voltages into velocities. Calibration may either be carried out in a dedicated probe calibrator, which normally is a free jet, or in a wind-tunnel with for example a pitot-static tube as the velocity reference. It is important to keep track of the temperature during calibration. If it varies from calibration to measurement, it may be necessary to correct the CTA data records for temperature variations.

Velocity calibration procedure:

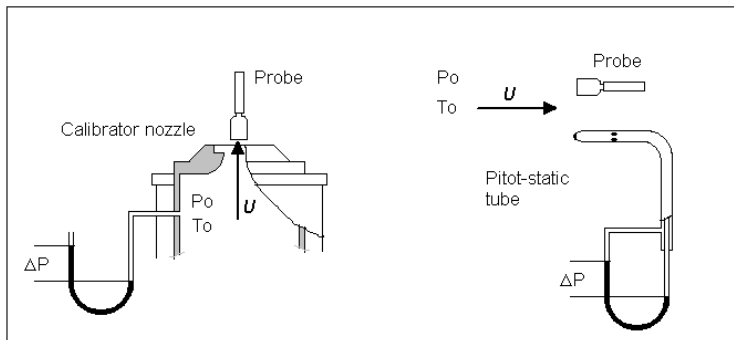

Mount the probe in the calibration rig with the same wire-prong orientation as will be used during the experiment.

- Single-sensor probes: with the prongs parallel with the flow.
- X-probes and Tri-axial probes: with the probe axis parallel with the flow.

Record the ambient conditions: Temperature, T_a , and barometric pressure, P_b .

Setting to operate:

1) Calibration with *temperature correction*:

Switch the anemometer to Operate with the previously established overheat set-up.

2) Calibration with *overheat adjustment*:

Balance the bridge immediately before calibration and establish a new overheat set-up using the same overheat ratio a .

Choose min. and max. calibration velocity, $U_{min,cal}$ and $U_{max,cal}$,

Choose number of calibration points (a minimum of 10 points is recommended).

Choose velocity distribution (logarithmic distribution is recommended).

Create the velocities and acquire the CTA voltage together with velocity and ambient temperature in all points.

Research type anemometers may be delivered with automatic calibrators and calibration routines in their application software, thus offering fully automatic calibrations inclusive of curve fitting.

CTA application software packages contain curve fitting procedures, which correct the voltages and calculates the transfer functions on basis of advanced curve fitting methods eliminating the need for any data manipulations by the user.

Curve fitting of calibration data (manual procedure):

U	E	T	Pbar	Ecorr
m/s	volts	C	Pa	volts
2.019	1.614	26.0	100.652	1.615
2.622	1.661	26.0	100.654	1.662
3.358	1.705	26.0	100.66	1.706
4.360	1.758	25.9	100.663	1.759
5.621	1.813	25.9	100.66	1.814
7.324	1.876	25.9	100.654	1.877
9.379	1.939	25.9	100.652	1.94
12.121	2.01	25.9	100.652	2.011
15.364	2.08	25.9	100.657	2.081
20.101	2.166	25.9	100.657	2.167

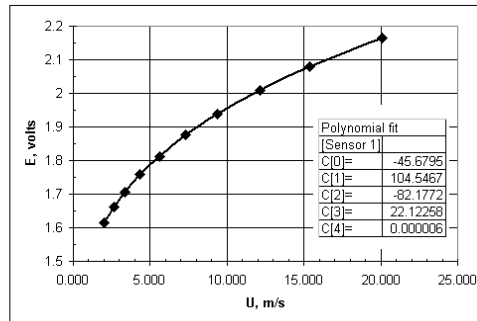

Arrange the probe data in a table, for example in Excel, containing velocity U , CTA voltage E , fluid temperature T_a and pressure P_b .

Correct the voltages E for temperature variations during calibration, see Chapter 8.1.2.

Polynomial curve fitting:

Plot U as function of E_{corr}

Create a polynomial trend line in 4th order:

$$U = C_0 + C_1 E_{corr} + C_2 E_{corr}^2 + C_3 E_{corr}^3 + C_4 E_{corr}^4, \text{ } C_0 \text{ to } C_4 \text{ are calibration constants.}$$

The polynomial curve fit is normally recommended, as it makes very good fits with linearisation errors often less than 1%.

Note: Polynomial curve fits may oscillate, if the velocity is outside the calibration velocity range.

Power law curve fitting:

Plot E^2 as function of U^n in double logarithmic scale ($n=0.45$ is a good starting value for wire probes).

Create a linear trend line. This will give the calibration constants A and B in the function:

$$E^2 = A + B \cdot U^n \text{ (King's law [15])}$$

Vary n and repeat the trend line until the curve fit errors are acceptable.

Power law curve fits are less accurate than polynomial fits, especially over wide velocity ranges, as n is slightly velocity dependent.

Velocity calibration of X-probes and Tri-axial probes:

The calibration velocity range must be expanded with respect to the velocity limits expected during the experiment thus making sure that the curve fit is valid over the full angular acceptance range of the probes. $U_{min,exp}$ and $U_{max,exp}$ are peak values.

	$U_{min,cal}$	$U_{max,cal}$
X-probes	$0.1 \cdot U_{min,exp}$	$1.5 \cdot U_{max,exp}$
Tri-axial probes	$0.15 \cdot U_{min,exp}$	$1.6 \cdot U_{max,exp}$

7. DIRECTIONAL CALIBRATION

Directional calibration of multi-sensor probes provides the individual directional sensitivity coefficients (yaw factor k and pitch-factor h) for the sensors, which are used to decompose calibration velocities into velocity components.

Note: In many situations, where optimal accuracy is not needed, the manufacturer's default values for k and h can be used, eliminating the need for individual directional calibration.

7.1.1 X-array probes

The yaw coefficients, k_1 and k_2 , are used in order to decompose the calibration velocities U_{cal1} and U_{cal2} from an X-probe into the U and V components.

Directional calibration of X-probes requires a rotation unit, where the probe can be rotated on an axis through the crossing point of the wires perpendicular to the wire plane. Calculation of the yaw coefficients requires that a probe coordinate system is defined with respect to the wires (see the sketch below), and that the probe has been calibrated against velocity.

X-probe calibration procedure:

Define probe coordinate system (X, Y) with respect to wire 1 and 2 as shown below:

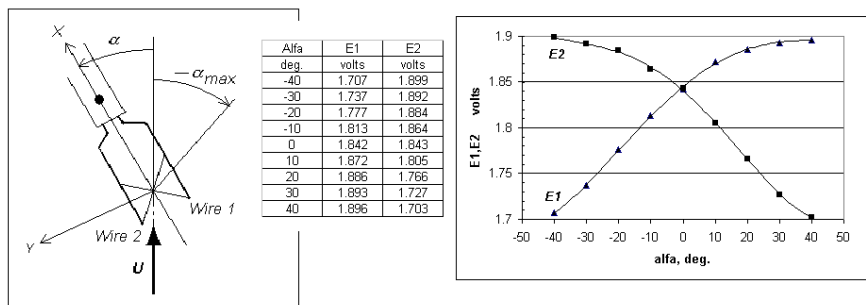

Mount the probe in the rotating holder oriented as shown above.

Estimate the maximum angle α_{max} , which is expected in the experiment between the velocity vector U_α and the probe axis. In most cases α_{max} is selected to = 40°.

Select the number of angular positions for the calibration.

Expose the probe to the middle calibration velocity $U_{dir,cal} = 1/2 \cdot (U_{min,cal} + U_{max,cal})$

Rotate the probe to the $-\alpha_{max}$ position and acquire the voltages E_1 and E_2 from the two sensors.

Check that E_1 is bigger than E_2 and that E_1 increases, while E_2 decreases, when the probe is moved to next angular position. If not turn the probe 180° around its X-axis and start again.

Read E_1 and E_2 in each angular position.

Calculate the squared yaw factor k_1^2 and k_2^2 for sensor 1 and sensor 2 in each position using the equations in Chapter 8.1.4.

Calculate the average of the k_1^2 and k_2^2 , respectively, factors and use them as sensitivity factors for the two sensors.

7.1.2 Tri-axial probes

The directional sensitivity of tri-axial probes is characterised by both a yaw and a pitch coefficient, k and h , for each sensor. Calibration of tri-axial probes requires a holder, where the probe axis (X-direction) can be tilted with respect to the flow and thereafter rotated 360° around its axis. Proper evaluation of the coefficient requires that a probe coordinate system is defined with respect to the sensor-orientation. Directional calibration is made on the basis of a velocity calibration.

Tri-axial probe calibration procedure:

Define a probe coordinate system (normally use the manufacturer's suggestion):

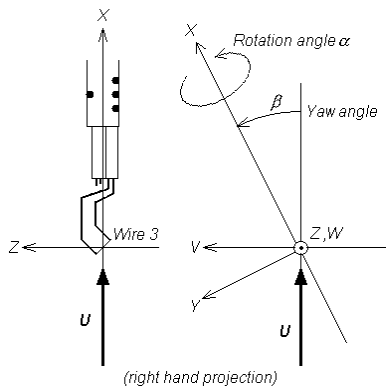

Alfa	E1	E2	E3
deg.	volts	volts	volts
0	1.983	1.841	1.963
15	1.98	1.807	1.981
30	1.975	1.789	1.995
45	1.965	1.768	1.997

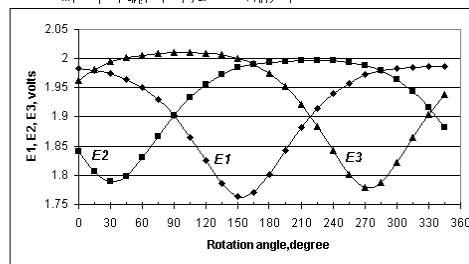

90	1.99	1.966	1.922
135	1.985	1.944	1.885
180	1.986	1.916	1.905
225	1.986	1.882	1.938

Mount the probe in the rotating holder with the probe axis in the flow direction and wire no. 3 in the XZ plane of the calibration unit system, corresponding to $\alpha=0$.

Estimate the maximum angle β_{max} , which is expected in the experiment between the velocity vector and the probe axis. In most cases β_{max} is selected to 30°.

Select the number of angular positions α for the calibration, normally 24 corresponding to 15° steps.

Expose the probe to the mid calibration velocity range $U_{dir,cal} = 1/2 \cdot (U_{min,cal} + U_{max,cal})$ and acquire the voltages E_1 , E_2 and E_3 from the three sensors.

Tilt the probe to the β_{max} position with $\alpha=0$ and acquire E_1 , E_2 and E_3 .

Rotate the probe and acquire E_1 , E_2 and E_3 in all α -positions.

Calculate the squared yaw factor k_1^2 , k_2^2 and k_3^2 and pitch factors for sensor 1, 2 and 3 in each position using the equations in Chapter 8.1.5.

Calculate the average of the k^2 - and h^2 -factors and use them as sensitivity factors for the three sensors.

Note: Directional calibration normally only needs to be carried out once in a probe's lifetime, as it depends only on the geometry, which will not change in use.

8. DATA CONVERSION

It is advised to define the data conversion prior to running the experiment. Data conversion transforms the CTA voltages into calibration velocities in m/s by means of the calibration transfer function. Multi-sensor probes are furthermore decomposed into velocity components in the probe coordinate system. If it differs from the laboratory coordinate system, the velocity components are finally transformed into the laboratory coordinate system.

Data conversion consists of the following processes:

<i>1. Re-scaling of acquired CTA output voltages (raw data)</i>	Only if Signal Conditioner gain and offset have been applied.
<i>2. Temperature correction</i>	Only if sensor temperature has been kept constant during experiment (no overheat adjust).
<i>3. Linearisation</i>	Only if data reduction in amplitude domain is required.
<i>4. Decomposition into velocity components</i>	Only for X-probes and Tri-axial probes.

Commercial CTA application software contains modules for data conversion, where raw data are converted into velocity components according to the scheme above. Unless special conditions prevail, it is recommended to use such dedicated software packages.

8.1.1 Re-scaling:

When a CTA signal has been subject to a DC-offset and amplification between overheat set-up and calibration, it has to be re-scaled before it can be linearised.

Re-scaling of CTA-signals:

Calculate the re-scaled voltage E from the acquired voltage E_a :

$$E = \frac{E_a}{Gain} - E_{offset}$$

8.1.2 Temperature correction:

If the overheat ratio has *not* been adjusted prior to the data acquisition, the CTA output voltage must be corrected for possible temperature variations before conversion. The fluid temperature needs then to be acquired along with the CTA signal.

Temperature correction of CTA voltages:

Acquire the fluid temperature, T_a , together with the CTA voltage, E_a .

Calculate the corrected CTA voltage, E_{corr} , from:

$$E_{corr} = \left(\frac{T_w - T_0}{T_w - T_a} \right)^{0.5} \cdot E_a \quad [60]$$

where:

E_a = acquired voltage

T_w = sensor hot temperature = $\alpha/a_0 + T_0$

T_0 = ambient reference temperature related to the last overheat set-up before calibration

T_a = ambient temperature during acquisition

This expression can be used for moderate temperature changes in air $\pm 5^\circ\text{C}$. The useful range may be expanded by reducing the exponent n from 0.5 to 0.4 or 0.3.

8.1.3 Conversion into calibration velocities (linearisation)

The CTA voltages are converted into velocities by inserting the acquired voltages into the calibration transfer functions after re-scaling and temperature correction, if needed. The simplest and most accurate transfer function is the polynomial, at least in the case of a wide dynamic velocity range.

The velocities are calculated as if the velocity attacked the probe under the same angle during measurement as during calibration.

Polynomial linearisation of CTA voltages:

Insert the acquired CTA voltage (after possible corrections) into the polynomial:

$$U = C_0 + C_1 E_{corr} + C_2 E_{corr}^2 + C_3 E_{corr}^3 + C_4 E_{corr}^4$$

where C_0 to C_4 are the calibration constants.

Note: Do not use the polynomial linearisation function outside the calibration range, as it may oscillate.

Power law linearisation of CTA voltages:

Insert the acquired CTA voltage (after possible corrections) into the function:

$$U = \left(\frac{E^2}{B} - A \right)^{\frac{1}{n}}$$

where A , B and n are the calibration constants.

8.1.4 X-probe decomposition into velocity components U and V

In 2-D flows measured with X-probes, the calibrated velocities together with the yaw coefficient k^2 are used as intermediate results to calculate the velocity components U and V in the probe coordinate system.

The yaw coefficients for the two sensors may be the manufacturer's default values, or if higher accuracy is required they are determined by directional calibration of the individual sensor. In simple cases, the coefficients may be neglected.

Decomposition of X-probe voltages into U and V:

Calculate the calibration velocities U_{cal1} and U_{cal2} using the linearisation functions for sensor 1 and 2.

Decomposition with yaw coefficients k_1 and k_2 :

Calculate the velocities U_1 and U_2 in the wire-coordinate system (1,2) defined by the sensors using the two equations:

$$k_1^2 \cdot U_1^2 + U_2^2 = \frac{1}{2} \cdot (1 + k_1^2) \cdot U_{cal1}^2$$

$$U_1^2 + k_2^2 U_2^2 = \frac{1}{2} \cdot (1 + k_2^2) \cdot U_{cal2}^2$$

which gives:

$$U_1 = \frac{\sqrt{2}}{2} \cdot \sqrt{(1 + k_2^2) \cdot U_{cal2}^2 - k_2^2 \cdot U_{cal1}^2}$$

$$U_2 = \frac{\sqrt{2}}{2} \cdot \sqrt{(1 + k_1^2) \cdot U_{cal1}^2 - k_1^2 \cdot U_{cal2}^2}$$

Calculate the velocities U and V in the probe coordinate system (X,Y) from:

$$U = \frac{\sqrt{2}}{2} \cdot U_1 + \frac{\sqrt{2}}{2} \cdot U_2$$

$$V = \frac{\sqrt{2}}{2} \cdot U_1 - \frac{\sqrt{2}}{2} \cdot U_2$$

Manufacturer's (Dantec Dynamics) default values for Yaw-coefficients, k^2 :

	$k_1^2 = k_2^2$
Miniature wire probes:	0.04
Gold-plated wire probes:	0.0225
Fiber-film probes for air:	0.04

8.1.5 Tri-axial probe decomposition into velocity components U, V and W

In a 3-D flows measured with a Tri-axial probe the calibration velocities are used together with the yaw and pitch coefficients k^2 and h^2 to calculate the three velocity components U, V and W in the probe coordinate system (X,Y,Z).

The yaw and pitch coefficients for the three sensors may be the manufacturer's default values, or if higher accuracy is required they are determined by directional calibration of the individual sensors.

Decomposition of Tri-axial probe voltages into U, V and W:

Calculate the calibration velocities U_{cal1} , U_{cal2} , U_{cal3} using the linearisation functions for sensor 1, 2 and 3.

Decomposition with individual yaw and pitch coefficients:

Calculate the velocities U_1 , U_2 and U_3 in the wire-coordinate system (1,2,3) defined by the sensors using the three equations:

$$k_1^2 \cdot U_1^2 + U_2^2 + h_1^2 \cdot U_3^2 = (1 + k_1^2 + h_1^2)^2 \cdot \cos^2 35.3 \cdot U_{cal1}^2$$

$$h_2^2 \cdot U_1^2 + k_2^2 \cdot U_2^2 + U_3^2 = (1 + k_2^2 + h_2^2)^2 \cdot \cos^2 35.3 \cdot U_{cal2}^2$$

$$U_1^2 + h_3^2 \cdot U_2^2 + k_3^2 U_3^2 = (1 + k_3^2 + h_3^2)^2 \cdot \cos^2 35.3 \cdot U_{cal3}^2$$

With the $k^2=0.0225$ and $h^2=1.04$ default values for a tri-axial wire probe, the velocities U_1 , U_2 and U_3 in the wire coordinate system becomes:

$$U_1 = \sqrt{-0.3676 \cdot U_{cal1}^2 + 0.3747 \cdot U_{cal2}^2 + 0.3453 \cdot U_{cal3}^2}$$

$$U_2 = \sqrt{0.3453 \cdot U_{cal1}^2 - 0.3676 U_{cal2}^2 + 0.3747 \cdot U_{cal3}^2}$$

$$U_3 = \sqrt{0.3747 \cdot U_{cal1}^2 + 0.3453 \cdot U_{cal2}^2 - 0.3676 \cdot U_{cal3}^2}$$

Calculate the U, V and W in the probe coordinate system:

$$U = U_1 \cdot \cos 54.74 + U_2 \cdot \cos 54.74 + U_3 \cdot \cos 54.74$$

$$V = -U_1 \cdot \cos 45 - U_2 \cdot \cos 135 + U_3 \cdot \cos 90$$

$$W = -U_1 \cdot \cos 114.09 - U_2 \cdot \cos 114.09 - U_3 \cdot \cos 35.26$$

Manufacturer's (Dantec Dynamics) default values for k^2 and h^2 :

	k^2	h^2
Gold-plated wire sensors:	0.0225	1.04
Fiber-film sensors for air:	0.04	1.20

9. DATA ACQUISITION

The CTA signal is a continuous analogue voltage. In order to process it digitally it has to be sampled as a time series consisting of discrete values digitized by an analogue-to-digital converter (A/D board).

The parameters defining the data acquisition are the *sampling rate* SR and the *number of samples*, N . Together they determine the *sampling time* as $T=N/SR$. The values for SR and N depend primarily on the specific experiment, the required data analysis (time-averaged or spectral analysis), the available computer memory and the acceptable level of uncertainty. Time-averaged analysis, such as mean velocity and rms of velocity, requires non-correlated samples, which can be achieved when the time between samples is at least two times larger than the integral time scale of the velocity fluctuations. Spectral analysis requires the sampling rate to be at least two times the highest occurring fluctuation frequency in the flow. The number of samples depends on the required uncertainty and confidence level of the results.

Time averaged analysis:

Estimate the following expected quantities in the flow:

velocity U [m/s], turbulence intensity Tu [%], and integral time-scale T_I [seconds] (see Chapter 10.2).

Select the wanted uncertainty and confidence level:

uncertainty u , %, in U_{mean}

confidence level $(1-a)$, %

Calculate the sampling rate SR :

$$SR \leq \frac{1}{2T_I} \text{ (gives uncorrelated samples)}$$

Calculate the number of samples N :

$$N = \left(\frac{1}{u} \cdot \left(\frac{z_a}{2} \right) \cdot Tu \right)^2$$

where $z_a/2$ is a variable related to confidence level $(1-a)$ of the Gaussian probability density function $p(z)$.

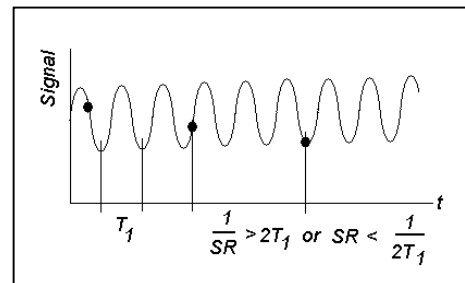

$z_a/2$	$(1-a)$ %
1.65	90
1.96	95
2.33	98

Sampling rate SR for time spectral analysis:

Calculate the sampling rate SR :

$SR \geq 2 \cdot f_{max}$ (Nyquist criteria with f_{max} based on an oversampled time series), or

$SR = 2 \cdot f_{cut-off}$ (based on low-pass filter set-up),

or

$SR = 2.5 \cdot f_{cut-off}$ (the factor 2.5 adopts to a non-ideal low-pass filter, which does not set the signal to zero at the cut-off frequency [57]).

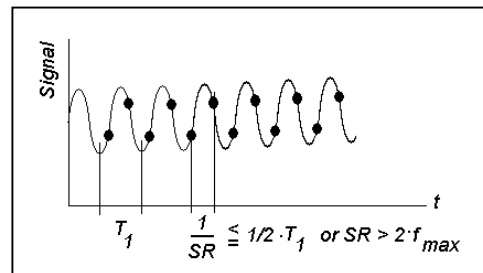

10. DATA ANALYSIS

As the CTA signal from a turbulent flow will be of random nature, a statistical description of the signal is necessary. The time series can be analysed or reduced either in the amplitude domain, the time domain or in the frequency domain. The following procedures all require stationary random data.

CTA application software contains modules that perform the most common data analysis, as defined below. The standard procedure is to select the wanted analysis and apply it to the actual time series. The reduced data will then be saved in the project and be ready for graphical presentation or for exporting to a report generator.

10.1 Amplitude domain data analysis

The amplitude domain analysis provides information about the amplitude distribution in the signal. It is based on one or more time series sampled on the basis of a single integral time-scale in the flow. A velocity time series represents data from one sensor, converted into a velocity component in engineering units.

A *single* velocity time series provides mean, mean square and higher order moments.

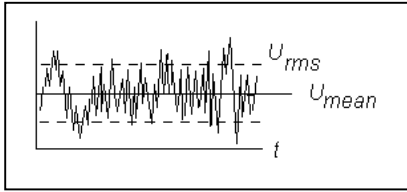
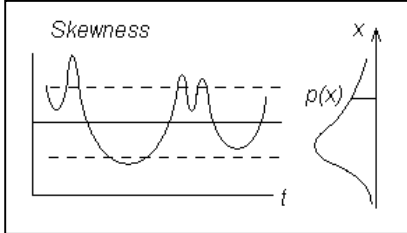
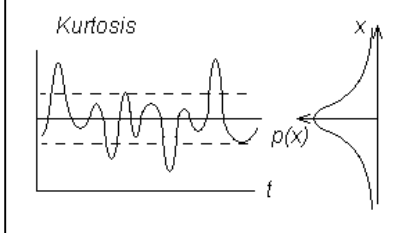
Moments based on a single time series:		
Mean velocity:	$U_{mean} = \frac{1}{N} \sum_1^N U_i$	
Standard deviation of velocity:	$U_{rms} = \left(\frac{1}{N-1} \sum_1^N (U_i - U_{mean})^2 \right)^{0.5}$	
Turbulence intensity:	$Tu = \frac{U_{rms}}{U_{mean}}$	
Skewness:	$S = \frac{\sum_1^N (U_i - U_{mean})^3}{N \cdot \sigma^3}$	
Kurtosis (or flatness):	$K = \frac{\sum_1^N (U_i - U_{mean})^4}{N \cdot \sigma^4}$	
where the variance σ is defined as:		
	$\sigma = \left(\frac{\sum_1^N (U_i - U_{mean})^2}{N-1} \right)^{0.5}$	
The Skewness is a measure of the lack of statistical symmetry in the flow, while the Kurtosis is a measure of the amplitude distribution (flatness factor).		

Two simultaneous velocity time series provide cross-moments (basis for Reynolds shear stresses) and higher order cross moments (lateral transport quantities), when they are acquired at the same point. If they are acquired at different points they provide spatial correlations, which carries information about typical length scales in the flow.

Moments based on two time series:

Reynolds shear stresses: $\overline{uv} = \frac{1}{N} \sum_1^N (U_i - U_{mean}) \cdot (V_i - V_{mean})$

$$\overline{uw} = \frac{1}{N} \sum_1^N (U_i - U_{mean}) \cdot (W_i - W_{mean})$$

$$\overline{vw} = \frac{1}{N} \sum_1^N (V_i - V_{mean}) \cdot (W_i - W_{mean})$$

Lateral transport quantities: $\overline{u^2v} = \frac{1}{N} \sum_1^N (U_i - U_{mean})^2 \cdot (V_i - V_{mean})$

$$\overline{u^2w} = \frac{1}{N} \sum_1^N (U_i - U_{mean})^2 \cdot (W_i - W_{mean})$$

$$\overline{v^2u} = \frac{1}{N} \sum_1^N (V_i - V_{mean})^2 \cdot (U_i - U_{mean})$$

$$\overline{v^2w} = \frac{1}{N} \sum_1^N (V_i - V_{mean})^2 \cdot (W_i - W_{mean})$$

$$\overline{w^2v} = \frac{1}{N} \sum_1^N (W_i - W_{mean})^2 \cdot (V_i - V_{mean})$$

10.2 Time-domain data analysis

The most often applied time-domain statistic is the auto-correlation function, $R_x(\tau)$, from which the integral time-scale can be calculated. This is an important quantity, as it defines the time interval between statistically uncorrelated samples.

In most CTA application software with data reduction features, the auto-correlation coefficient function is normally calculated and graphically displayed. It starts with the value 1 at time zero, drops down to zero and normally continues oscillating around zero. A reasonable estimate of T_I is the time it takes the coefficient to drop from the unity start value to zero.

Auto-correlation function and integral time-scale:

Requires a long time series $x(t)$ sampled according to the Nyquist criteria.

Auto-correlation function:

$$R_x(\tau) = \lim_{T \rightarrow \infty} \frac{1}{T} \int_0^T x(t) \cdot x(t + \tau) \cdot dt$$

Integral time-scale:
$$T_I = \int_0^{\infty} \rho_x(\tau) \cdot d\tau$$

where the auto-correlation

coefficient is defined as:
$$\rho_x(\tau) = \frac{R_x(\tau)}{R_x(0)}$$

Note: Auto-correlation can be made on non-linearised raw data.

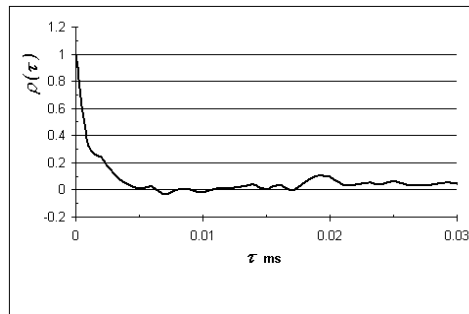

10.3 Spectral-domain data analysis

Spectral analysis can be used to provide information about how the energy of the signal is distributed with respect to frequency.

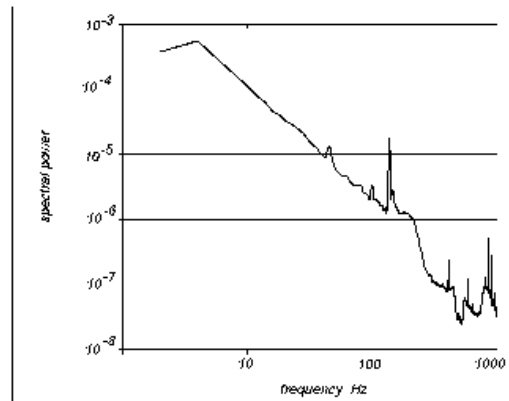
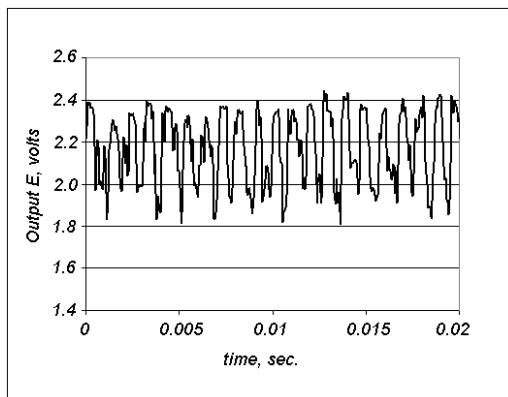

Power spectrum of the flow behind a circular cylinder.

The analysis can be performed on raw, non-linearised signals, provided they are sampled according to the Nyquist criteria. The accuracy of the spectra depends on the algorithm used and on the number of samples, which normally must be high. There exist a number of different algorithms for the calculation of spectra mostly based on Fourier transforms, which produce values of discrete frequencies within sub-records of the signal. Normally CTA application software contains routines for spectral analysis.

11. RUNNING AN EXPERIMENT

The experiment can be executed when system set-up, probe calibration, data acquisition set-up, and data reduction (algorithms for data analysis) have been established. Prior to running the experiment it is advised to verify the complete set-up by performing measurements in a known part of the flow. Probe calibrations before and after the experiment are advisable in order to check probe stability.

11.1 General procedure:

Before the experiment can start, the measuring system must be configured, the CTA bridge and Signal Conditioner set up and the data acquisition and data reduction defined in accordance with the flow characteristics.

Running an experiment, general procedure:

Calibrate the probe(s). It is always recommended to calibrate the probe immediately before and after an experiment.

Verify the set-up:

Position the probe in a part of the flow, which is reasonably well known, and acquire data in one or more points.

Perform data reduction in both amplitude and spectral domain (U_{mean} , U_{rms} and *Power spectra* as minimum).

Compare with expected values.

Check stability of statistics by comparing results from data records of different lengths.

Adjust data acquisition set-up (sample rate SR and number of samples N), if need be.

Position the probe in the flow together with a temperature probe, if temperature correction of data is required.

Move the probe to the proper position in the traverse grid (if employed).

Acquire the CTA output voltages together with other signals needed for correction or control and move to next position.

Analyse (reduce) data before the experiment is shut down, if possible.

Re-calibrate the probe after the experiment and compare with previous calibration. This can be done in practice by reducing the same raw data set by means of the two calibrations and compare the results.

Note: If the calibration drifts linearly with time during an experiment, the drift may be compensated for by using a new transfer function based on the averages of velocities calculated from identical voltage values inserted into the transfer functions from the first and the second calibrations. $U_{av} = (U_1 + U_2) / 2 = (f_{cal1}(E_1) + f_{cal2}(E_1)) / 2$.

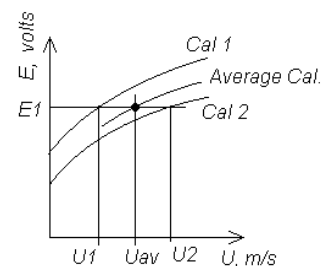

11.2 Experimental procedure in non-isothermal flows:

As the CTA anemometer is sensitive to variations in ambient temperature, as well as velocity, it is often necessary to make special precautions in non-isothermal flows in order to eliminate errors in the measured velocity due to temperature variations. The error in the velocity measured with a wire probe in air is approximately 2% per 1°C change in air temperature. The measured velocity decreases with increasing temperature and vice versa.

This error may be avoided by setting up the CTA bridge and correcting the data in one of the following ways:

1. Operate the probe with a **constant sensor temperature** (obtained by leaving the decade resistor in the CTA fixed during calibration and data acquisition) and correct the CTA voltage before linearisation and data reduction. The ambient temperature must be acquired simultaneously with a temperature sensor, which is fast enough to follow the temperature variations.
2. Operate the probe with a **constant overheat ratio** (obtained by adjusting the overheat ratio before each calibration and data acquisition). This requires that the ambient temperature remains constant (or nearly constant) during the time it takes to perform a data acquisition.

CTA set-up and Data conversion in non-isothermal flows:

Constant sensor temperature (fixed decade resistance) with temperature correction of data:

Adjust the overheat ratio a at a known ambient temperature T_{ref} .

Leave the CTA bridge and make no more overheat adjustments during the experiment or during recalibrations (disable “automatic overheat adjust” in StreamLine).

Calibrate the probe and measure temperature in each calibration point. Correct the raw voltages to T_{ref} and make a curve fit.

Position the probe in the test rig and acquire the CTA voltages, E_a , and ambient temperature, T_a , as close to the probe as possible.

Correct the raw CTA voltages (see **Chapter 8.1.2**) before further conversion (linearisation) and reduction.

Constant overheat ratio without temperature correction of data:

Adjust the overheat ratio, a , at a known ambient temperature T_a . (Enable “Automatic overheat adjust” in StreamLine).

Calibrate the probe at T_a and make a curve fit.

Position the probe in the test rig and re-adjust the overheat ratio, a , at the new ambient temperature.

Acquire the CTA voltages E .

Convert (linearise) and reduce the raw CTA voltages without any prior corrections.

12. DISTURBING EFFECTS

Measurements with hot-wire anemometers are influenced by a number of disturbing effects. In fact any change in a parameter that enters into the mechanism of heat transfer from the wire to its surroundings may act as a disturbing effect and reduce the accuracy of the measurement result. The effects may be related to the flow medium and sensor condition. For special effects from e.g. natural convection, wall nearness etc. please refer to the *Chapter 14*.

12.1 Flow related effects:

12.1.1 Temperature:

Temperature variations are normally the most important error source, as the heat transfer is directly proportional to the temperature difference between the sensor and the fluid. For a wire probe operated under normal conditions, the error in measured velocity is approx. 2% per 1°C change in temperature. For film probes in water the error may be up to 10% per 1°C. In both cases the measured velocity decreases with increasing ambient temperature.

Different precautions can be taken in order to avoid systematic conversion errors when probe voltages are converted into velocities. One solution is to readjust the overheat resistor to the changed temperature, so that overheat ratio is kept constant from calibration to measurement. Another solution is to leave the overheat resistor constant, measure the temperature and correct the probe voltage. See *Chapter 11.2 Experimental procedure in non-isothermal flows*. A special case is the temperature-compensated wire probe with build-in temperature-sensitive overheat resistor which measures velocity independent of temperature variations.

12.1.2 Pressure:

Pressure variations:

Pressure variations enter directly into the heat transfer equation, as the probe in fact measures the mass flux $\rho \cdot U$. Normally probes are calibrated against velocity only. As pressure variations from calibration to experiment and during an experiment are normally small, the pressure influence in the CTA measurements is normally neglected.

Pressure range:

The lower limit for pressures, at which a probe can be used, are determined by the slip-flow conditions defined by the Knudsen number Kn (ratio between molecular mean free path and sensor diameter should be smaller than 0.01). For a 5 μm wire probe at atmospheric conditions $Kn=0.02$. Provided density variations are small the flow is considered to be a continuum, and pressure effects are normally neglected.

12.1.3 Composition:

In most cases the fluid composition remains constant during calibration and experiment, and it is of no importance. In air one normally experiences variations in water vapour content (humidity). The influence is very small, less than 1%, and is almost always neglected.

12.2 Sensor conditions

12.2.1 Contamination:

Particle contamination reduces the heat transfer resulting in a downward drift in the calibration. The influence of particle contamination increases with decreasing sensor surface. Wire probes with 5 μm sensors can be used without problems in normal laboratory air, if they are recalibrated at regular intervals. Fiber-film probes are less susceptible and can be used, e.g. in outdoor applications without problems. If the calibration drifts significantly, it may be necessary to clean the sensor.

Contamination is a much bigger problem in liquid flows than in gas flows. This means that film probes with non-cylindrical sensors should always be preferred for fiber-film probes whenever possible, unless a careful filtering of the water is carried out.

12.2.2 Sensor Robustness:

Normally all probes will survive almost any experiment, when safely placed in the test rig. By far the most damages to sensors happen during handling. It is, however, wise to take the robustness of the probe into consideration before it is selected for a particular application. In general the robustness increases with the size of the sensor.

12.2.3 Sensor orientation:

The effect of sensor orientation is neglectible as long as the sensor is placed identically with respect to the flow during calibration and measurement. The misalignment is normally so small that it may be neglected as an error source.

13. UNCERTAINTY OF CTA MEASUREMENTS

Current standards refer to the ISO uncertainty model which combines uncertainty contributions $U(y_i)$ from each individual input variable x_i into a total uncertainty at a given confidence level. The output variable is defined as $y_i=f(x_i)$.

The relative standard uncertainty $u(y_i)$ is a function of the standard deviation of the input variance:

$$u(y_i) = \frac{1}{y_i} \cdot S \cdot \left(\frac{\Delta x_i}{k_i} \right)$$

where $S = \partial y_i / \partial x_i$ is the sensitivity factor and k_i is the coverage factor related to the distribution of the input variance (Gaussian, rectangular etc.).

As most engineering applications are assumed to have a Gaussian error distribution, the 95% confidence level normally required is achieved by multiplying the standard uncertainty with the coverage factor $k=2$. The total relative expanded uncertainty then becomes:

$$U(tot) = 2 \cdot \sqrt{\sum u(y_i)^2}$$

The uncertainty of the results obtained with the CTA anemometer is a combination of the uncertainties of the individually acquired voltages converted into velocity and the uncertainty of the statistical analysis of the velocity series. The following chapters provide a guide on how to estimate the uncertainties of CTA measurements under normal conditions.

13.1 Uncertainty of a velocity sample

This chapter presents the uncertainty of a single velocity sample acquired via an A/D board from a CTA anemometer with a single-sensor probe. The uncertainty of each individual velocity sample is determined by non-statistical means based on detailed knowledge about the *instrumentation, calibration equipment and experimental conditions*. The uncertainties presented below are *relative standard* uncertainties.

13.1.1 Anemometer

Drift, noise, repeatability and frequency response:

Commercially available anemometers have low drift, low noise and good repeatability so that these factors do not add significantly to the uncertainty in comparison with other error sources. In certain applications, e.g. dissipation measurements, the high frequency noise of the anemometer may be of importance.

The frequency characteristic of the anemometer will not add to the uncertainty, when the frequencies in the flow are below approximately 50% of the cut-off frequency (from the square wave test), as the characteristic is normally flat up to this point.

13.1.2 Calibration/conversion

Calibration equipment:

The calibration, whether it is performed with a dedicated calibrator or with a pitot-static tube as reference, constitutes a major source of uncertainty. The error is *stochastic* with a normal distribution and the *relative standard* uncertainty can be expressed as:

$$U(U_{cal}) = \frac{1}{100} \cdot STDV(U_{calibrator} (\%))$$

The calibrator uncertainty is often given as a *relative standard* uncertainty, a_{cal} , in percent plus a constant contribution b_{cal} in m/s :

$$STDV(U_{calibrator}) = \pm a(\%) + b_{cal}(m/s)$$

The constant contribution b_{cal} may be normally neglected at velocities above 5 m/s.

	a_{cal} %	b_{cal} m/s
Good dedicated calibrator	± 1	± 0.02
Pitot-static tube with calibrated micro-manometer ($U_{cal} > 2$ m/s)	$\pm 2\%$	

Linearisation (Conversion)

The linearisation uncertainty is related to the curve fitting errors. It is stochastic with a normal distribution and its *relative standard* uncertainty can be calculated from:

$$U(U_{lin}) = \frac{1}{100} \cdot STDV(\Delta U_{lin} (\%))$$

where $STDV(\Delta U_{lin})$ is the standard deviation of the curve fitting errors in the calibration points in %.

13.1.3 Data acquisition related uncertainties

A/D board resolution

The resolution uncertainty is stochastic with a square distribution and its *relative standard* uncertainty can be expressed as:

$$U(U_{res}) = \frac{1}{\sqrt{3}} \cdot \frac{1}{U} \cdot \frac{E_{AD}}{2^n} \cdot \frac{\partial U}{\partial E}$$

where E_{AD} is the A/D board input range, n is its resolution in bits, U the velocity and $\partial U/\partial E$ is the slope (sensitivity factor) of the inverse calibration curve, $U=f(E)$.

13.1.4 Uncertainties related to experimental conditions

Probe positioning

The positioning uncertainty relates to the alignment of the probe in the experimental set-up after calibration. The uncertainty is stochastic with a square distribution and its *relative standard* uncertainty can be expressed as:

$$U(U_{pos}) = \frac{1}{\sqrt{3}} \cdot (1 - \cos \theta)$$

Normally a probe can be positioned with an uncertainty $\Delta\theta=1^\circ$.

Temperature variations

Temperature variations from calibration to experiment or during an experiment introduce systematic errors. If not corrected, a change in temperature changes the sensor over-temperature and contributes as a stochastic uncertainty with rectangular distribution. The *relative standard* uncertainty is:

$$U(U_{temp}) = \frac{1}{\sqrt{3}} \cdot \frac{1}{U} \cdot \frac{1}{T_w - T_0} \cdot \left(\frac{A}{B} \cdot U^{-0.5} + 1 \right)^{0.5}$$

where T_w is the sensor temperature, T_0 the ambient reference temperature, and ΔT is the difference between the ambient reference temperature and the temperature during the measurement.

This estimate is based on the power law calibration function:

$$E^2 = (T_w - T_0) \cdot (A + B \cdot (U_{cal})^{0.5}) = (T_w - T_0) \cdot (A + B_1 \cdot (\rho \cdot U)^{0.5})$$

Since the velocity U_{cal} actually represents the mass flux, ρU , variations in density, ρ , with temperature will add to the uncertainty, if not accounted for. In gases, this gives following *relative standard* uncertainty:

$$U(U_{\rho,T}) = \frac{1}{\sqrt{3}} \cdot \Delta\rho_{,T} = \frac{1}{\sqrt{3}} \cdot \frac{\Delta T}{273}$$

Ambient pressure variations

Ambient pressure changes also influence the density and hence the calculated velocity. It contributes as a stochastic uncertainty with rectangular distribution with following *relative standard* uncertainty:

$$U(U_{\rho,P}) = \frac{1}{\sqrt{3}} \cdot \left(\frac{P_0}{P_0 + \Delta P} \right)$$

Gas composition, humidity

Under normal conditions changes in gas composition are mainly caused by changes in humidity. The uncertainty is stochastic with a rectangular distribution having a *relative standard* contribution of:

$$U(U_{hum}) = \frac{1}{\sqrt{3}} \cdot \frac{1}{U} \frac{\partial U}{\partial P_{wv}} \cdot \Delta P_{wv}$$

The influence on the heat transfer is very small, $\partial U / \partial P_{wv} \approx 0.01 \cdot U$ per 1 kPa change in water vapour pressure P_{wv} .

13.1.5 Velocity sample uncertainty

The relative expanded uncertainties on a single velocity sample obtained with a single-sensor hot-wire probe in air, can be summarized in the following table:

Input data are: $T_w - T_0 = 200$ °C, $U = 15$ m/s, $A = 1.396$, $B = 0.895$, $\partial U / \partial E = 46.5$ m/s/volt

Source of uncertainty	Input variants	Typical value	Relative output variants	Typical value	Coverage factor	Relative standard uncertainty
	Δx_i	Δx_i	$\frac{1}{U} \cdot \Delta y_i$	$\frac{1}{U} \cdot \Delta y_i$	k	$\frac{1}{k} \cdot \frac{1}{U} \cdot \Delta y_i$
Calibrator	ΔU_{cal}	1%	$2 \cdot \text{STDV}(100 \cdot \Delta U_{cal})$	0.02	2	0.01
Linearisation	ΔU_{fit}	0.5%	$2 \cdot \text{STDV}(100 \cdot \Delta U_{fit})$	0.01	2	0.005
A/D resolution	E_{AD} n	10 volts 12 bit	$\frac{1}{U} \cdot \frac{E_{AD}}{2^n} \cdot \frac{\partial U}{\partial E}$	0.0008	$\sqrt{3}$	0.0013
Probe positioning	θ	1 °	$1 - \cos \theta$	0.00015	$\sqrt{3}$	≈ 0
Temperature variations ¹⁾	ΔT	1 °C	$\frac{1}{U} \cdot \frac{\Delta T}{(T_w - T_0)} \cdot \left(\frac{A}{B} \cdot U^{-0,5} + 1 \right)$	0.013	$\sqrt{3}$	0.008
Temperature variations ²⁾	ΔT	1 °C	$\frac{\Delta T}{273}$	0.004	$\sqrt{3}$	0.002
Ambient pressure	ΔP	10 kPa	$\frac{P_0}{P_0 + \Delta P}$	0.01	$\sqrt{3}$	0.006
Humidity	ΔP_{wv}	1 kPa	$\frac{1}{U} \cdot \frac{\partial U}{\partial P_{wv}} \cdot \Delta P_{wv}$	0.0006	$\sqrt{3}$	≈ 0
Relative expanded uncertainty ³⁾ : $U(U_{sample}) = 2 \cdot \sqrt{\sum \left(\frac{1}{k} \cdot \frac{1}{U} \cdot \Delta y_i \right)^2} = 0.030 = 3 \%$						

Table 1. Error sources and uncertainties for a single velocity sample acquired with a CTA under typical experimental conditions including calibrator uncertainty.

- 1) Uncertainty due to change in sensor overtemperature alone.
- 2) Uncertainty due to change in air density with temperature alone.
- 3) The two uncertainties from temperature variations are inter-correlated and should be added arithmetically before they are added geometrically to the other uncertainties.

From above example it appears that the voltage from a CTA with a wire probe can be acquired and converted into a velocity sample with an uncertainty of approximately 1 % with a 95% confidence interval with reference to the calibration and neglecting the uncertainty of the calibrator itself. When the uncertainty of calibrator is included, the uncertainty of a velocity sample increases to typically 3%. The major contributions come from the calibrator, temperature variations in the flow and the linearisation (curve fitting). Variations in atmospheric pressure may also play a role.

13.2 Uncertainty of reduced data

The uncertainty of reduced data (mean velocity, standard deviation of velocity etc.) depends on the uncertainty of the individual samples as described in chapter 11.1 and on how true the data represents the flow. As the data presents a random process the choice of sampling rate and number of samples is most important for the uncertainty due to the sampling process. The criteria for this choice are shortly described in *Chapter 9*, where it is demonstrated how the number of samples can be calculated on the basis of known turbulence intensity, and the required uncertainty and confidence level.

For further reading please consult the literature.

14. Advanced topics

Very low velocities

At very low velocities the heat transfer from the wire is governed by natural convection. This means that the cooling not only depends on the magnitude of the velocity but also its orientation with respect to the gravity field. The influence of natural convection starts around 0.2 m/s for wire probes and takes over completely around 0.03-0.04 m/s. In this range it is important that the probe has the same orientation with respect to the velocity field during calibration and measurement [22].

High velocities, compressible flows

At high velocities the flow becomes compressible and effects from compressibility should be taken into account. In practice this means that pressure and velocity should be measured simultaneously. The correction is quite complicated and is very often neglected [33],[48], [55].

Rarified flows (low pressures)

When the pressure decreases the mean free path of the molecules increases. If the Knudsen number Kn (free mean path divided by wire diameter) gets larger than 0.01, the heat transfer becomes a function of both velocity and Knudsen number (or pressure). For a 5 micrometer diameter wire the Kn is around 0.02 at atmospheric conditions. If lower pressures occur, it should be considered to use fibre-film probes instead of wire probes [8].

Wall effects

When the wire is placed close to a solid wall, heat will be conducted through the flowing medium to the wall. If not corrected for this will cause the velocity to be measured too high. The wall influence starts at $y^+ \leq yU\tau/\nu = 3.5$ (y = distance to the wall, $U\tau$ =friction velocity and ν =kinematic viscosity). The critical wall distance is typically 0.1 to 0.2 mm depending on free stream velocity [53], [62], [22].

Very high turbulence, reversing flows

If the turbulence is very high, above 30% or more, or in reversing flows, where the velocity vector falls outside the opening angle of the sensor array, the results will be incorrect. Such flows can be measured correctly with flying hot-wire systems, where the probe is moved through the flow field with a speed high enough to move the resulting velocity vector inside the opening angle. After linearisation the flying speed is subtracted from the longitudinal velocity component [52], [56].

Wall shear stress

Wall shear stress can be measured with flush mounting film probes mounted in the wall. The heat transfer can then be expressed as a function of the wall shear stress. The probes have to be calibrated in a known shear. It should be noted that the secondary heat transferred to the wall changes the frequency response of wall mounted probes as compared to freely mounted film probes [25], [37].

Two-phase flows

As the heat transfer is much bigger in liquids than in gases, a hot wire (or hot-film) will clearly distinguish between liquid and gas phase. This can be utilised to measure the passage of for example air bubbles in water [20].

Binary mixtures

The heat transfer to gases depends to some extent on the heat conductivity of the gas. The heat transfer from a wire can therefore be used to measure the concentration in binary mixtures. This is done in practice by placing the wire in a sonic nozzle (aspirating probe), where the probe is exposed to a constant velocity independent of the free stream velocity and therefore primarily responds to changes in heat conductivity [44].

15. THE CTA ANEMOMETER, BASIC PRINCIPLES

The hot-wire anemometer was introduced in its original form in the first half of the 20th century. A major breakthrough was made in the fifties, where it became commercially available in the presently used constant temperature operational mode (CTA). Since then it has been a fundamental tool for turbulence studies. The measurement of the instantaneous flow velocity is based upon the heat transfer between the sensing element, for example a thin electrically heated wire or a metal film, and the surrounding fluid medium. The rate of heat loss depends on the excess temperature of the sensing element, its physical properties and geometrical configuration, and the properties of the moving fluid. A hot-wire anemometer provides reliable information on the fluctuating flow component in both the space and time domains.

15.1 Characteristics of the hot-wire sensing element

15.1.1 Static characteristics - stationary heat transfer

The relationship between the fluid velocity and the heat loss of a cylindrical wire is based on the assumption that the fluid is incompressible and that the flow around the wire is potential. When a current is passed through wire, heat is generated ($I^2 R_w$). During equilibrium, the heat generated is balanced by the heat loss (primarily convective) to the surroundings. If the velocity changes, then the convective heat transfer coefficient will also change resulting in a wire temperature change that will eventually reach a new equilibrium with the surroundings.

The experimentally obtained static calibration curve is typically plotted as hot-wire voltage versus flow velocity. It may be described by a power law relationship given in terms of the non-dimensional parameters Reynolds number, Re , Nusselt number, Nu , and the Prandtl number, Pr . Empirically this type of dependency is valid for $0.01 < Re < 10^4$ [15]. Actually the heat loss is influenced by a number of other factors like: natural convection at very low velocities, compressibility effects at high velocities, density effects at low pressures. Please refer to the Hot-wire literature concerning these more specialised matters.

15.1.2 Dynamic characteristics, frequency limit.

The hot-wire response can be derived from the nonstationary heat balance equation. When exposed to changes in flow velocity the wire will not react instantaneously due to its thermal inertia. This will dampen the variations in wire resistance R_w (and in wire voltage) and result in flow fluctuations being measured smaller than they actually are. The wire response alone is far too slow for most turbulence studies, and compensation in the electronics of the anemometer is therefore necessary. By using the Constant Temperature Anemometer principle, whereby a feed-back amplifier keeps the sensor resistance constant independent of variations in U , the frequency limit may be increased up to 1000 times or more [10], [12].

Governing equation:

Consider a thin heated wire mounted to supports and exposed to a velocity U .

$$W = Q + \frac{dQ_i}{dt}$$

W = power generated by Joule heating

$W = I^2 R_w$, recall $R_w = R_w(T_w)$

Q = heat transferred to surroundings

$Q_i = C_w T_w$ = thermal energy stored in wire

C_w = heat capacity of wire

T_w = wire temperature

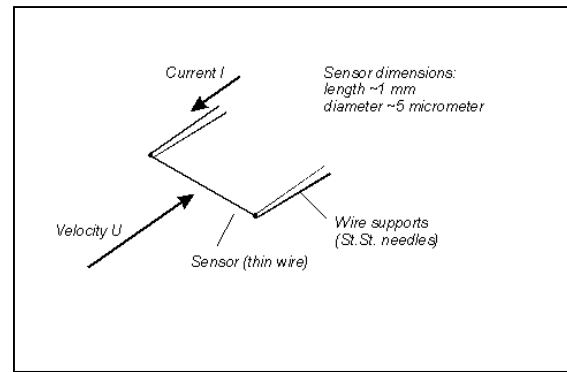

Static characteristics – stationary heat transfer:

Heat storage in the wire is zero:

$$W = Q = I^2 R = hA(T_w - T_0)$$

or replacing h with Nu :

$$I^2 R_w = \frac{A}{d} Nu k_f (T_w - T_0)$$

h = film coefficient of heat transfer

A = heat transfer area

d = wire diameter

k_f = heat conductivity of fluid

Nu = dimensionless heat transfer coefficient

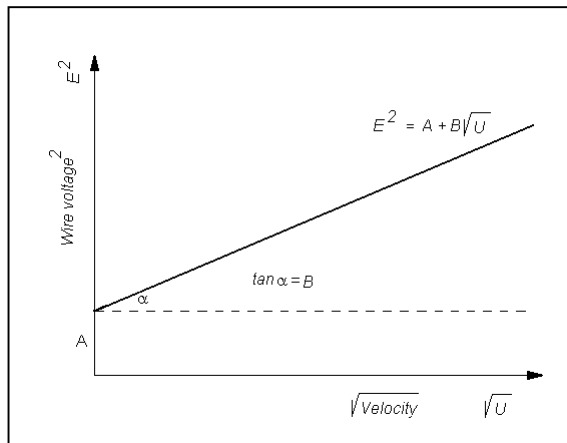

In the forced convection regime ($0.02 < Re < 140$):

Reynolds number: $Re = \frac{\rho \cdot U \cdot d}{\mu}$, ρ = air density, U = velocity and μ = air dynamic viscosity.

$$Nu = A_1 + B_1 \cdot Re^n = A_2 + B_2 U^n$$

$I^2 R_w^2 = E^2 = (T_w - T_0)(A + BU^n)$ “King’s law” [15]. The voltage is a measure of velocity U .

Dynamic characteristics- frequency limit:

Heat storage term added to the stationary heat transfer equation:

$$I^2 R_w = (R_w - R_0)(A + BU^n) + C_w \frac{dT_w}{dt}$$

or expressing T_w in terms of R_w and temperature coefficient of resistance α_0 :

$$I^2 R_w = (R_w - R_0)(A + BU^n) + \frac{C_w}{\alpha_0 R_0} \frac{dR_w}{dt}$$

This differential equation has the time constant τ .

$$\tau = \frac{C_w}{\alpha_0 R_0 (A_1 + B_1 U^n - I^2)}$$

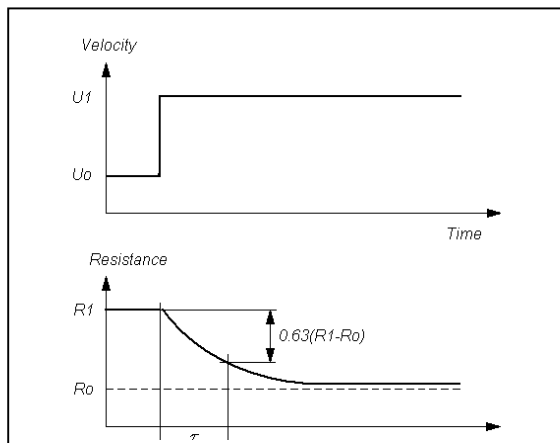

Frequency limit (3 dB amplitude damping):

$$f_{cp} = \frac{1}{2\pi\tau}$$

15.2 Mechanical design of hot-wire probes

A hot-wire probe for the measurement of high frequency flow fluctuations consists of a very thin wire mounted on some kind of support. The hot-wire material is chosen so as to fulfil a number of requirements such as: high temperature coefficient of resistance, high specific resistance, high mechanical strength and ability to operate at high temperatures. Tungsten is far superior to other metals in this respect and is therefore used, whenever possible. It can be used at wire temperatures up to 300°C and at velocities even in the supersonic range. Most hot-wires have a diameter of 5 μm and a length of approximately 1 mm. The wire is spot-welded to needle-shaped prongs, normally made of stainless steel. The prongs are embedded in a probe body, which electrically connects to the anemometer via a probe support and cable.

15.3 Spatial resolution of hot-wires

The space volume over which the hot-wire output averages depends on the wire size, its frequency limit and the flow velocity. The resolution length in the direction of the flow will be directly proportional to the mean velocity and inversely proportional to the upper frequency limit of the hot-wire inclusive of the anemometer circuit. The upper frequency limit of an anemometer should be chosen so that the resolution length in the direction of the mean flow velocity is of the same order of magnitude as the length of the wire. At 50 m/s an anemometer with a frequency limit of 25 kHz a typical wire probe will have a spatial resolution of 1 mm in the streamwise direction.

15.4 Directional sensitivity of hot-wires

The heat transfer relation for a hot-wire, which forms basis for its static calibration, assumes that the velocity vector is directed normal to the wire. In fact the heat transfer strongly depends on the angle between the velocity vector and the wire. In the case of an ideal sensor, where there is no heat conduction to the prongs, the heat transfer varies with the cosine of the angle between the velocity and the wire normal. In reality heat is conducted to the prongs and a directional sensitivity factor k (yaw-factor), which describes the prong interference, has to be introduced. In a 3-dimensional flow, where the velocity moves out of the wire-prong plane, the heat transfer will increase due to increased cooling of the prongs. This can be described by the pitch factor h .

Individual directional calibration of hot-wires, in addition to velocity calibrations, makes it possible to measure both velocity magnitude and direction in 2 or 3-dimensional flows using probes with 2- or 3-wires arranged in orthogonal arrays.

Probe design

Tungsten wire is spot-welded to stainless steel prongs embedded in a ceramic tube.
Gold-plated probes have plated wire ends in order to minimise prong effects.

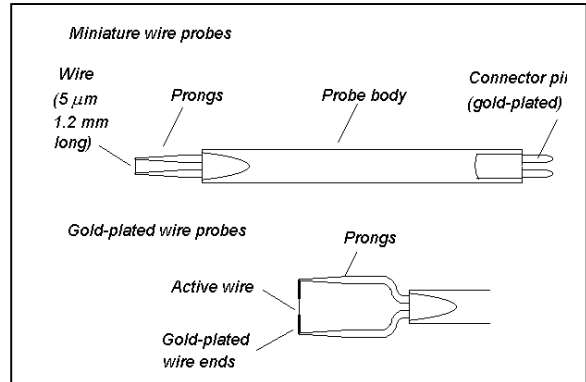

Spatial resolution

Hot-wire resolution l_x in streamwise direction:

$$l_x = \frac{U_{mean}}{2f_{cp}} \quad [5].$$

U_{mean} = mean velocity

f_{cp} = frequency limit

High spatial resolution at high velocity requires high bandwidth

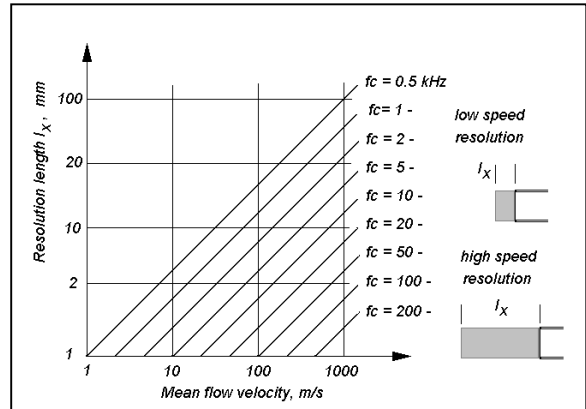

Directional sensitivity

Finite wire response includes yaw and pitch Sensitivity [24], [29].:

$$U(\alpha)^2 = U(0)^2 (\cos^2 \alpha + k^2 \sin^2 \alpha) \quad \theta = 0$$

$$U(\theta)^2 = U(0)^2 (\cos^2 \theta + h^2 \sin^2 \theta) \quad \alpha = 0$$

General response in 3-D flows:

$$U_{eff}^2 = U_x^2 + k^2 U_y^2 + h^2 U_z^2$$

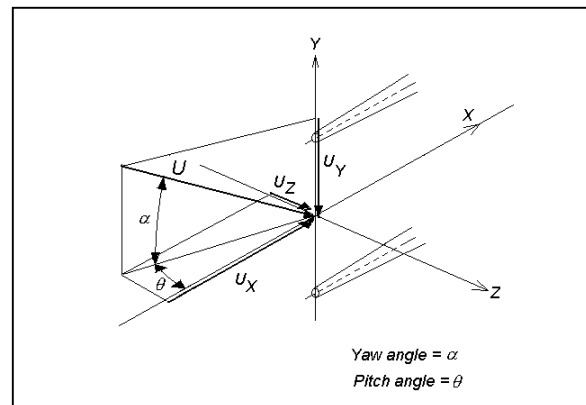

$U(0)$: actual velocity in the flow

U_{eff} : effective cooling velocity (calculated from velocity calibration)

α : yaw angle (angle between velocity and wire normal)

θ : pitch angle (angle between velocity and wire wire-prong plane)

k : yaw factor

h : pitch factor

(x, y, z) : probe oriented coordinate system

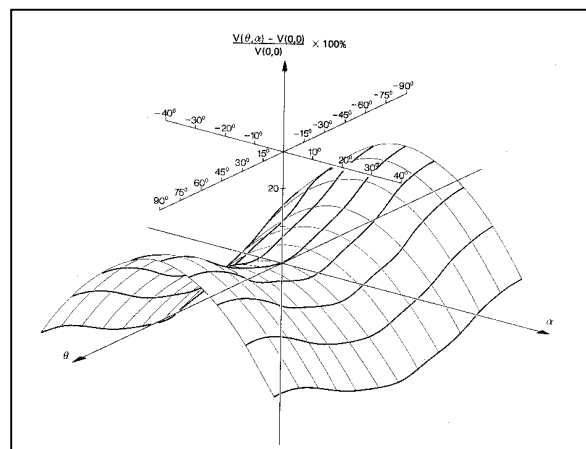

15.5 The Constant Temperature Anemometer.

The constant temperature anemometer is designed with the purpose of eliminating the influence of the thermal inertia of the wire in fluctuating flows, so that the frequency limit of the instrument is mainly determined by the electronic circuitry. This is achieved by supplying electrical energy to the wire at exactly the same rate as heat is lost to the surrounding fluid medium and at the same time. Since the wire temperature is thus kept constant irrespective of the flow velocity, the importance of the heat capacitance of the wire is greatly diminished.

The operation of the CTA anemometer can be explained as follows:

The hot-wire is placed in one arm of a Wheatstone bridge opposite a variable resistor, which defines the operating resistance, and hence the operating temperature of the hot-wire. In the case the bridge is in balance, no voltage difference exists across its diagonal. Now, if the flow velocity increases, the wire resistance will tend to decrease and an error voltage will be present at the input of the current regulating amplifier. This will cause the probe current to increase. The wire will heat and increase in resistance until the balance is restored. Because of the high gain of the current regulating amplifier, a condition of bridge balance exists, which is practically independent of the flow velocity past the wire. The wire time constant is thus reduced by a factor of several hundred times from fractions of a millisecond to some few microseconds. The probe current is represented by the voltage drop across the bridge. As all resistances in the bridge are constant, the squared output voltage E^2 directly represents the heat loss from the wire and can replace Q in the heat transfer equation for the wire.

CTA anemometer principle diagram

Main components are:

Wheatstone bridge:

Probe: R_w

Overheat resistor: R_3

Top resistors: R_1 and R_2

Feedback loop:

Amplifier: G

Gain shape control: S^*

Filter: F^*

Power amplifier: P^*

Cable compensation: C^*

* not shown in principle diagram.

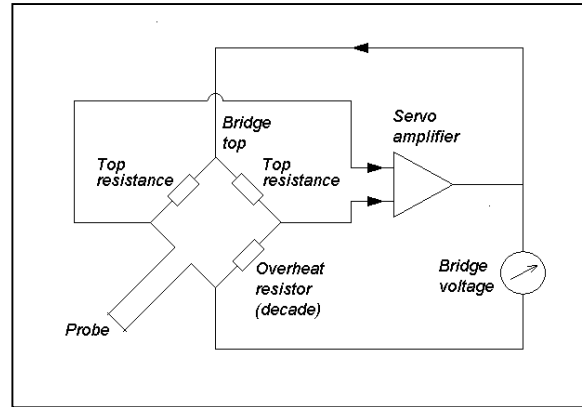

Improved wire response:

The servo-loop amplifier increases the wire frequency limit:

$$f_{c,CTA} = 2aSR_w f_{c,wire}$$

τ_w = wire time constant alone

a = overheat ratio

R_w = wire resistance

S = amplifier gain

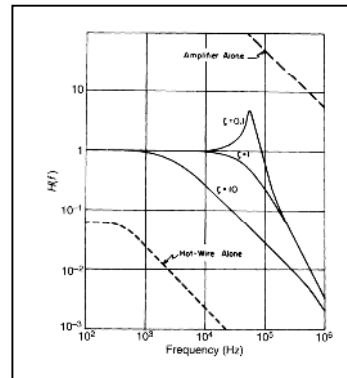

Typical CTA frequency response:

Typical frequency response (amplitude damping and phase lag) of CTA with 5 μ m wire probe.

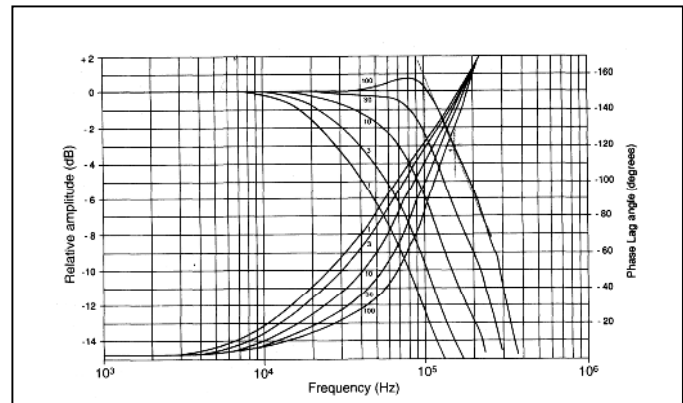

Typical velocity response:

The relation between the CTA output E and the velocity U represents the probe calibration, from which the transfer function $U = f(E)$ is derived.

$$U = \left(\frac{E^2}{B} - \frac{A(T_w - T_0)}{B} \right)^{\frac{1}{n}} \text{ or}$$

$$U = C_0 + C_1 E + C_2 E^2 + C_3 E^3 + C_4 E^4$$

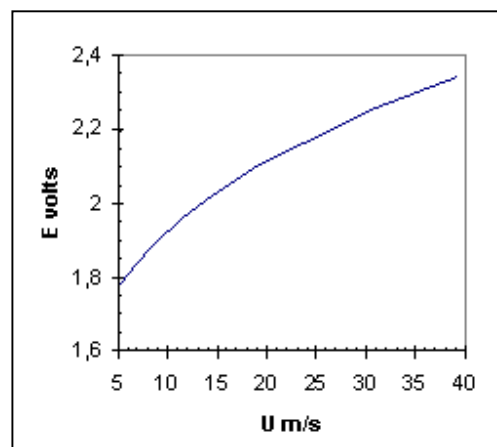

16. REFERENCES

The hot-wire anemometer literature counts more than 1200 titles covering almost all aspects of anemometry, ranging from the design of advanced electronic circuitry over sophisticated signal interpretation and data reductions to practical hints on how to mount and operate a hot-wire in a specific application. H.H. Bruun's book on Hot-Wire Anemometry from 1995 is the most comprehensive reference text book for the selection and use of hot-wire/hot-film anemometry techniques published so far. It contains an almost complete list of references up to the date of printing. Other valuable sources are DISA Information 1965-1985, which was replaced by Dantec Information 1985-1995.

The below short list of references contains some of the more important text books and papers but does not intend to be neither complete, nor fully representative. It should be regarded only as a tool, by which one can get either immediate help or be guided to more adequate references. Copies of most of the listed papers are available from Dantec Dynamics on request.

Text books on Hot-wire Anemometry

1. Bradshaw, P.: "An Introduction to Turbulence and its Measurement". Pergamon Press 1971.
2. Bruun, H.H.: "Hot-Wire Anemometry, Principles and Signal Analysis". Oxford Science Publications 1995.
3. Compte-Bellot, G.: "Hot-wire Anemometry." The Handbook of Fluid Dynamics edited by R.W. Johnson CRC Press LLC, 1998.
4. Fingerson, L.M.: "Thermal Anemometers". Fluid Mechanics Measurements. Edited by R.J. Goldstein. Hemisphere Publishing/Springer 1983.
5. Kovásnay, L.S.G.: "Turbulence Measurements". Physical Measurements in Gas Dynamics and Combustion. Edited by R.W.Ladenburg et al. Princeton University Press 1954.
6. Lomas, C.G.: "Fundamentals of Hot Wire Anemometry". Cambridge University Press 1986.
7. Sandborn, V.A.: "Resistance Temperature Transducers". Metrology Press 1972.

Papers on Hot-wire Anemometry in general

8. Baldwin, L.V. et al.: "Heat Transfer from Transvers and Yawed Cylinders in Continuum, Slip, and Free Molecule Air Flows." Journal of Heat Transfer, May 1960.
9. Bradshaw, P.: "Thermal methods of flow measurement." J. Phys. E.: Sci. Instrum. 1968 Series 2 Volume 1.
10. Freymuth, P.: "Frequency response and electronic testing for constant-temperature hot-wire anemometers." Journal of Physics E.: Scientific Instruments 1977 Volume 10, 705-710.
11. Freymuth, P.: "Calculations of square wave test for frequency optimised hot-film anemometers." Journal of Physics E.: Scientific Instruments 1981 Volume 14, 238-240.
12. Freymuth, P.: "Interpretations in the control theory of thermal anemometers." Meas. Sci. Technol. 8 (1997) 174-177.
13. Freymuth, P.: "Second or third order control theory for constant-temperature hot-wire anemometers." Experiments in Fluids 23 (1997) 175-170.
14. Jørgensen, F.E.: "The computer-controlled constant-temperature anemometer. Aspects of set-up, probe calibration, data acquisition and data conversion." Meas. Sci. Technol. 7 (1996) 1378-1387.
15. King, L.V.: "On the convection of heat from small cylinders in a stream of fluid: Determination of the convection constants of small platinum wires with applications to hot-wire anemometry." Phil. Trans. Roy. Soc. A214 (1914), 373-432.
16. Weiss, J. et al.: "Method for the determination of frequency response and signal to noise ratio for constant-temperature hot-wire anemometers". Review of Scientific Instruments, Volume 72, Number 3, March 2001.

Papers on Probes and probe response

17. Bellhouse, B.J. et al.: "Low-Frequency Characteristics of Hot-Film Anemometers." DISA Information No. 6. 1968.
18. Bergström, H. et al.: "Calibration of a Three-Axial Fiber-Film System for Meteorological Turbulence Measurements". Dantec Information No. 5, 1987.
19. Bonis, M. et al.: "A Heat Transfer Law for a Conical Hot-film Probe in Water". DISA Information No. 14, 1973.
20. Bremhorst, K. et al.: "Response of hot-wire anemometer probes to a stream of air bubbles in a water flow." J. Phys. E.: Sci. Instrum. Volume 9, 1976.
21. Chew, Y.T. et al.: "The directional sensitivities of crossed and triple hot-wire probes." J. Phys. E.: Sci. Instrum. 21 (1988) 613-620.
22. Christman, P.C. et al.: "Hot-wire anemometer behaviour in low velocity air flow." J. Phys. E.: Sci. Instrum. 1976 Volume 14, 1981.
23. Collis, D.C. et al.: "Two-dimensional convection from heated wires at low Reynolds numbers." J. Fluid Mech., 6, (1959), 357-384.
24. Friehe, C.A. et al.: "Deviations from the Cosine Law for Yawed Cylindrical Anemometer Sensors." Journal of Applied Mechanics, Transactions of the ASME 68-WA/APM-16.
25. Geremia, J.O.: "Experiments on the Calibration of Flush Mounted Film Sensors." DISA
26. Gieseke, T.J.: "An experimental approach to the calibration and use of triple hot-wire probes." Experiments in Fluids 14, 305-315 (1993).
27. Hollash, K. et al.: "Calibration of Constant-Temperature Hot-Wire Anemometers at Low Velocities in Water with Variable Fluid Temperature." Journal of Heat Transfer, ASME Paper No. 71-HT-9.
28. Johnson, F.D. et al.: "A variable angle method of calibration for X-probes applied to wall-bounded shear flow." Experiments in Fluids 2, 121-130 (1984).
29. Jørgensen, F.E.: "Directional Sensitivity of Wire and Fibre-Film Probes." DISA Information No. 11. 1971.
30. Kassab, S.Z.: "Effect of the hot-wire length on the determination of the length scale of large eddies." Meas. Sci. Technol. 2 (1991) 647-652.
31. Ligrani, P.M. et al.: "Subminiature hot-wire sensors: development and use." J. Phys. E.: Sci. Instrum. 20 (1987).
32. Marasli, B.: "A calibration technique for multiple-sensor hot-wire probes and its application to vorticity measurements in the wake of a cylinder." Experiments in Fluids 15, 209-218 (1993).
33. Norman, B.: "Hot-wire Anemometer Calibration at High Subsonic Speeds." DISA Information No. 5. 1967.
34. Perry, A.E. et al.: "Vibration of hot-wire anemometer filaments." J. Fluid Mech. (1967), vol. 50, part 4, pp. 815-825.
35. Schewe, J. et al.: "Error-tolerant calibration of dual sensor probes used in turbulent wall boundary layer." Experiments in Fluids 9, 285-289 (1990).
36. Strohl, A. et al.: "Aerodynamic Effects Due to Configuration of X-Wire Anemometers." Journal of Applied Mechanics, Transactions of the ASME 73-APM-P.
37. Sumer, B.M. et al.: "Two-component hot-film probe for measurement of wall shear stress." Experiments in Fluids 15, 380-384 (1993).
38. Tagawa, M. et al.: "Evaluation of X-probe response to wire separation for wall turbulence measurements." Experiments in Fluids 12, 413-421 (1992).
39. Teo, C.J. et al.: "The dynamic response of a hot-wire anemometer: IV. Sine wave voltage perturbation testing for near-wall hot-wire/film probes and the presence of low-frequency response characteristics." Meas. Sci. Technol. 12 (2001) 37-51.
40. Turan, Ö.F. et al.: "Effect of structural vibrations on hot-wire probe response." Widell, K.E.: "Stresses and Deformations in Hot-Wire Probes." DISA Information No. 2, 1965.
41. Yeung, C.P. et al.: "Numerical calibration and verification tests of orthogonal triple-hot-wire probe." Meas. Sci. Technol. 4 (1993) 1446-1456.
42. Zank, I.: "Sources of Errors and Running Calibration of Three-Dimensional Hot-Film Anemometers Especially near the Sea Surface." DISA Information No. 26. 1981.

Papers on methods and applications

43. Abdel-Rahmann, A.A.: "An X-array hot-wire technique for heated turbulent flows of low velocity." *J. Phys. E.: Sci. Instrum.* 22 (1989) 638-644.
44. Brown, G.L. et al.: "A Small, Fast-Response Probe to Measure Gas Composition of Binary Gas Mixtures." *AIAA Journal*, Vol. 10, No. 5, 1972, 649-652.
45. Bruun, H.H. et al.: "Velocity component measurements by X hot-wire anemometry." *Meas. Sci. Technol.* 1 (1990) 1314-1321.
46. Butterfield, R.G.: "Application of thermal anemometry and high-frequency measurement of mass flux to aeolian sediment transport." *Geomorphology* 29 (1999) 31-58.
47. Chew, Y.T. et al.: "A critical evaluation of the explicit data analysis algorithm for a crossed wire anemometer in highly isotropic flow." *Meas. Sci. Technol.* 1 (1990) 775-781.
48. Demin, V.S.: "Interpretation of Hot-Wire Anemometer Readings in a Flow with Velocity, Pressure and Temperature Fluctuations." *Fluid Mechanics- Soviet Research*, Vol. 2, No. 3, May-June 1973.
49. Frota, M.N.: "Analysis of the Uncertainties in velocity Measurements and Technique for Turbulence Measurements in Complex Heated Flows with Multiple Hot Wires". Stanford University 1982.
50. Gaullier, C.: "Measurement of Air Velocity by Means of a Triple Hot-Wire Probe." *DISA Information No.* 21. 1977.
51. Hoffmeister, M.: "Using a Single Hot-Wire Probe in Three-Dimensional Turbulent Flow Fields." *DISA Information No.* 13. 1972.
52. Kelso, R.M. et al.: "A novel flying hot-wire system." *Experiments in Fluids* 16, 181-186 (1994).
53. Khoo, B.C. et al.: "On near-wall hot-wire measurements." *Experiments in Fluids* 29, 448-460 (2000).
54. Löfdahl, L.: "Hot-Wire Techniques for the Determination of the Reynolds Stress Tensor in Three-Dimensional Flows". *Dantec Information No.* 35, 1986.
55. Smiths, A.J. et al.: "Constant Temperature Hot-Wire Anemometer Practice in Supersonic Flows, Part 1: The Normal Wire: "Experiments in Fluids 1", 83-92 (1983).
56. Thompson, B.E.: "Appraisal of a Flying Hot-wire Anemometer". *Dantec Information No.* 4, 1987.
57. Van Dijk, A.: "Aliasing in one-point turbulence measurements." *Dissertation*, Technical University Delft 1999.
58. Wark, C.E. et al.: "A rotating hot-wire technique for spatial sampling of disturbed and manipulated duct flows." *Experiments in Fluids* 9, 191-196 (1990).
59. Wyngaard, J.C.: "Measurement of small-scale turbulence structure with hot-wires." *J. Phys. E.: Sci. Instrum. Series 2 Volume 1*, 1968.

Papers on disturbing effects

60. Bearman, P.W.: "Corrections for the Effect of Ambient temperature Drift on Hot-Wire Measurements in Incompressible Flows." *DISA Information No.* 11. 1971.
61. Durst, F. et al.: "Influence of humidity on hot-wire instruments". *Meas. Sci. Technol.* 7 (1996) 1517-1528.
62. Hebbbar, K.S.: "Wall Proximity Corrections for Hot-Wire Readings in Turbulent Flows." *DISA Information No.* 25. 1980.
63. Löfdahl, L. et al.: "The influence of temperature on the measurements of Reynolds stresses in shear free turbulence near a wall." *Experiments in Fluids* 25, 160-164 (1998).
64. Martinez- Val, R. et al.: "Sensor contamination Effects in Hot-Wire Anemometry in Air." *DISA Information No.* 27. 1982.
65. Mojola, O.O.: "The Effects of Orientation of a Hot-Wire Probe Body in Turbulent Shear Flow." *DISA Information No.* 23. 1978.
66. Firasat Ali, S.: "Hot-wire anemometry in moderately heated flow." *Rev. Sci. Instrum.*, Vol. 46, No. 2, 1975.
67. Bremhorst, K.: "Effect of fluid temperature on hot-wire anemometers and an improved method of temperature compensation and linearisation without use of small signal sensitivities." *J. Phys. E.: Sci. Instrum.* Vol. 18, 1985.
68. Schubauer, G.B.: "Effect of humidity in hot-wire anemometry." *National Bureau of Standards, Research Paper RP850*, 1935.

Appendix I

MiniCTA sample projects

Preparing for a MiniCTA project:

This chapter directs you to the working platform of the MiniCTA application software.

1. Create a folder for the database and project.

Switching on the MiniCTA:

Note that you should **not** connect the power adapter to the MiniCTA, before the probe is connected and the decade is adjusted to proper overheat ratio.

1-D Measurement in a Point

The anemometer output is connected to an input channel of the A/D board in the PC. It is assumed that the ambient temperature remains constant or nearly constant during the project.

Hardware list:

- 55P11 Probe with 55H20 Probe Support
- 9055A1863 Probe Cable, 4 m.
- 55T30 MiniCTA anemometer.
- Cable and Connector Box for the A/D board.
- PC with A/D board installed.

1. Connect the Analog Output bushing on the MiniCTA to the A/D board input 0 on the connector box for the A/D board with a 50 ohms BNC cable.
2. Connect Probe and Support with a 4 m Cable to the Probe BNC-connector on the MiniCTA.
3. Switch power on to both systems.

Open MiniCTA software:

Open MiniCTA software by double clicking on the MiniCTA Icon in the Program Manager. You are now prompted to create a new database.

Create a Database

1. Choose Database/New from the File menu.
2. Select the folder that you already have created for the purpose and type in the name of your new database, e.g. 1-wire.sdb.
4. Choose OK.

Create a Project:

You are now prompted to create a Project. Select Yes. A New Project dialog box opens.

1. Enter the name of your project and your initials in the Created by field.
2. Choose OK.

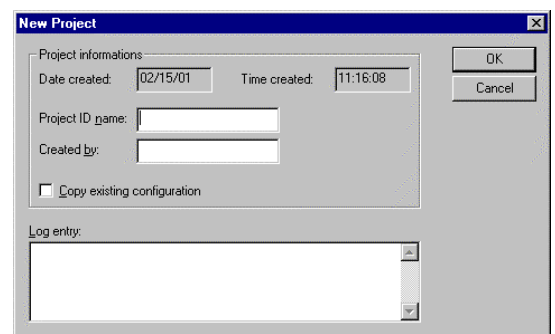
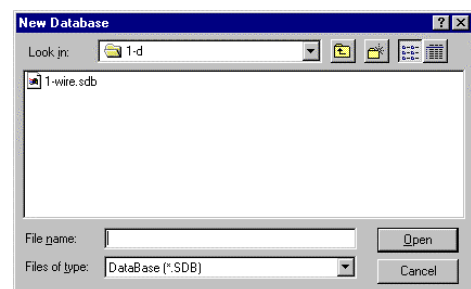
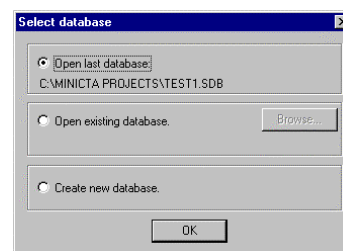
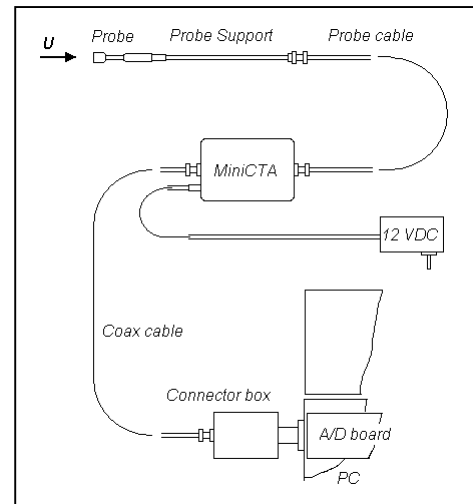

Define Devices:

You are now prompted to select an A/D board. Say Yes and the Device Library dialog box opens.

1. Select the A/D board that is installed in the PC.
2. Choose OK.

A path is now made from the project to the translation driver.

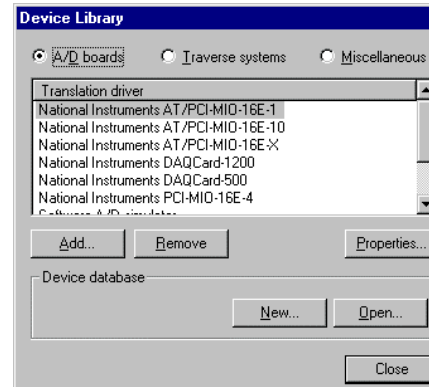

System Configuration:

You are now prompted to configure the system. Select Yes and the System Configuration dialog box opens.

Now select probe, cable/support and A/D input channel.

1. Click on the Single Wire sensor probe Icon.
2. Select Probe, Support and Cable dialog box opens.
3. Select 55P11 Wire, 55H20 Support and a 1864 BNC/BNC Cable in the list boxes.
4. Choose OK. The Probe, Support and Cable are now added to the map. It is by default connected to A/D input channel 0.
5. Choose OK.

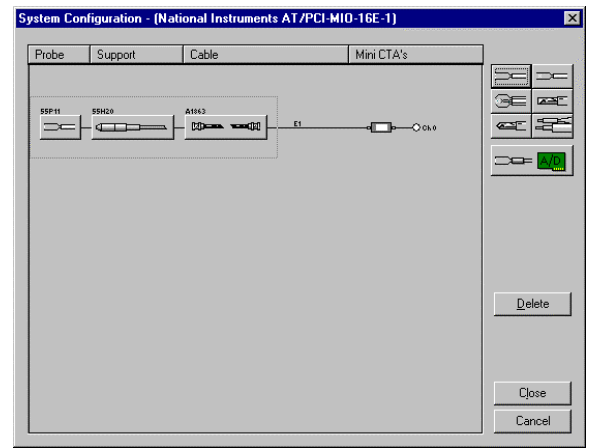

You are now prompted to define the Set-up.

Define Hardware Set-up

You are now prompted to define the set-up of the CTA.

Reference temperature and overheat from the probe library are displayed.

1. Enter the sensor cold resistance R₂₀ at 20°C from the label on the probe container.
2. Click Update and the probe operating data and the corresponding dip switch settings in the MiniCTA are displayed.
3. Click on OK and you are now prompted to carry out a velocity calibration of the probe.

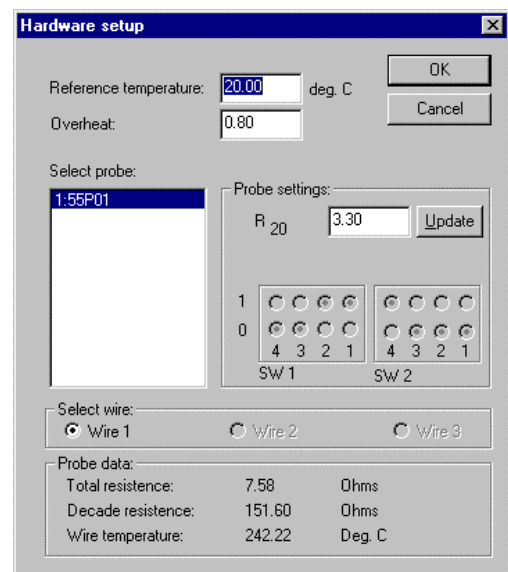

Velocity Calibration

It is assumed that you have some calibration means, e.g. a free jet or a windtunnel with e.g. a pitotstatic tube as velocity reference.

The Velocity Range dialog box opens.

1. Enter min. and max. velocity and number of calibration points.
2. Leave the Log distribution, as it gives the best linearisation accuracy over a wide velocity range and select OK.

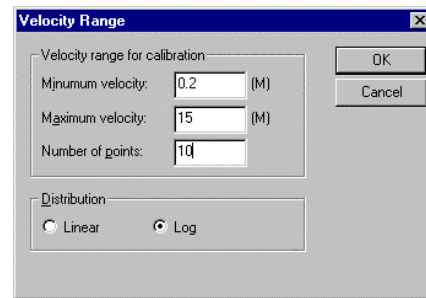

The Calibration dialog box opens.

1. Select Point 1. Create the displayed velocity. Enter the actual value from the keyboard.
2. Enter the temperature into the Temperature field from the keyboard.
3. Click on the Parameters Read button.
4. Click on the Voltages Read button. The probe voltage from the CTA is now read via the A/D board.
5. Click on the Update button. The velocity, temperature and probe voltage are now placed in the data sheet.
6. Select next point and continue until all points are done.
7. Click on the Fit button. The Curve fit analysis dialog box opens. It displays the curve fit coefficients and the linearisation errors. In this project please neglect the Temperature correction check box.

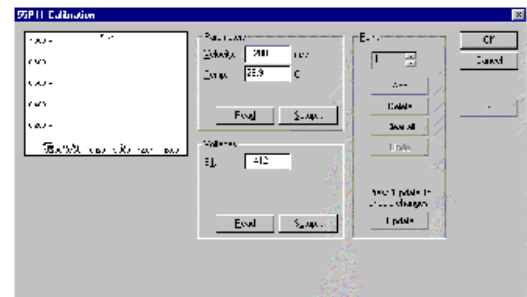

If you accept the quality of the calibration click on the OK button. The completed calibration data sheet is now displayed.

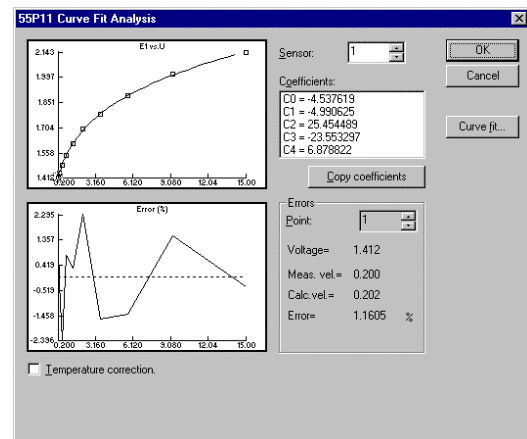

Close and save the calibration event:

1. Double-click in the Menu Control box in the upper left corner of the data sheet window. A Save event dialog box opens.
2. Type in an identification and select OK. The dialog box closes and you are prompted to create a Conversion event on basis of the probe calibration.
3. Say Yes. A Save event dialog box opens.
4. Type in an identification and select OK. The dialog box closes and you are prompted to make the Conversion event default. Say Yes.

A Calibration event and a Conversion/reduction event are added to the Project Manager.

	U	E1	T(C)	P(kPa)	E1corr	U1calc
1	0.200	1.412	26.800	0.000	1.412	0.202
2	0.323	1.444	26.900	0.000	1.444	0.322
3	0.522	1.486	26.700	0.000	1.486	0.510
4	0.843	1.546	26.900	0.000	1.546	0.850
5	1.363	1.614	26.800	0.000	1.614	1.367
6	2.202	1.698	26.900	0.000	1.698	2.252
7	3.557	1.783	26.900	0.000	1.783	3.500
8	5.747	1.888	27.000	0.000	1.888	5.665
9	9.284	2.014	26.900	0.000	2.014	9.424
10	15.000	2.143	26.800	0.000	2.143	14.942
11						
12						
13						
14						
15						
16						

Run Online:

You can now check the performance of the system in Online.

1. Choose Online analysis from the Run menu. Online dialog box opens.
2. Choose the Start button.

The Data display is now updated for each acquisition until you choose Stop or leave the dialog box.

You can display velocity instead of voltage by selecting Velocity from calibration in the "Output as" field. No data are stored during Online.

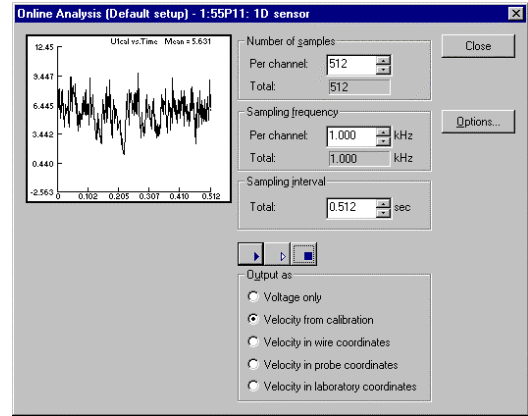

Default set-up:

The Default set-up consists of a hardware set-up and a loop defining probe positioning and data acquisition (sampling rate and number of samples). Finally the default conversion/reduction to be used on acquired data.

In the present example you need not change anything in the default set-up.

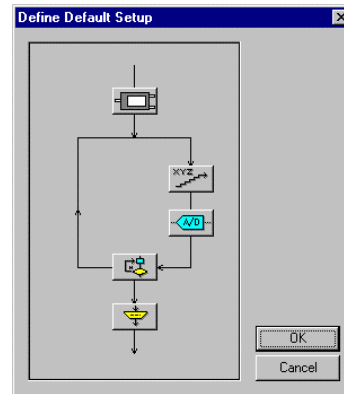

Run Default:

You can store acquired data in a file by running Default instead of Online

1. Choose Run default set-up from the Run menu or click on the Acquire data Icon in the Main toolbar.
2. An Acquire data to disk event dialog box appears
3. Type in the identification for the Raw data event that will be the result of the default run.
4. Close the dialog box by choosing OK.

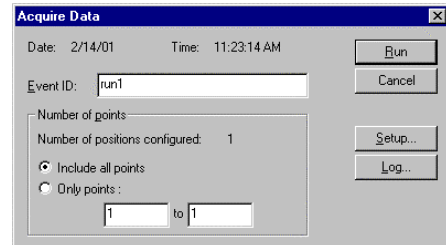

When finished, a Raw data record is added to the Project Manager.

Load Raw Data:

Raw data are stored in a file arranged with a database structure. In order to present the data, they have to be unpacked.

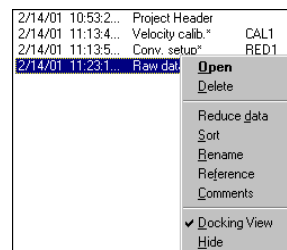

Point at the Raw data event in the Project Manager and click with the right mouse button and select Load. Raw Data Selection dialog box appears.

1. Choose Load.
A data sheet with the acquired data opens.
2. Choose Close. The dialog box closes and leaves the data sheet open.

	TIME	E1
1	0.000	5.000
2	0.001	4.983
3	0.002	4.966
4	0.003	4.951
5	0.004	4.934
6	0.005	4.919
7	0.006	4.902
8	0.007	4.888
9	0.008	4.871
10	0.009	4.856

Present Data in a Graph:

1. Choose Graph from New Window in the Window menu or click on the Graph Icon in the Main toolbar.
Select Data Dialog box appears.
2. Select U1cal in the Data column box.
3. Click on the Y--> button.
U1cal is now moved to the Y-arguments box.
4. Choose OK.

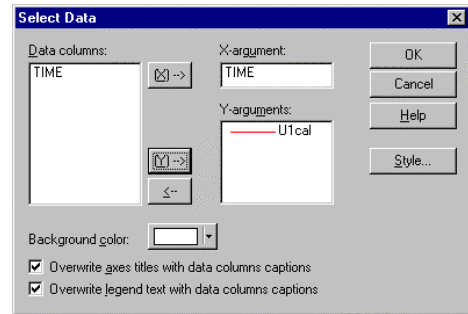

A Graph is now created with voltages as function of acquisition time.

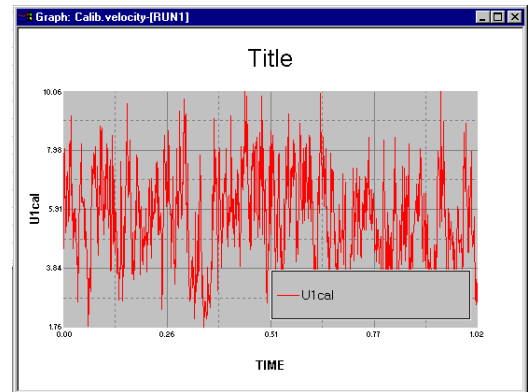

To Reduce Data:

1. Point at the Raw data event in the Project Manager and click with the right mouse button and select Reduce data.
A Save event dialog box opens. Note that the default Conversion event automatically will be used to convert and reduce the data.
2. Type in an identification and choose OK.
The Data reduction process is now carried out and a Reduced data event is added to the Project manager.

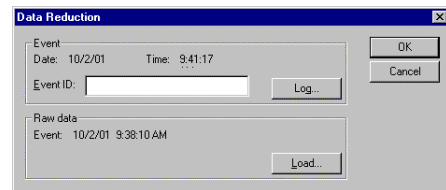

Load reduced data:

1. Point at the Reduced data event in the Project Manager and click with the right mouse button and select Load.
Data sheet showing the positions (0,0,0), the Umean and Urms. opens.

	X pos.	Y pos.	Z pos.	A pos.	U Mean	U RMS
1	0.000	0.000	0.000	0.000	5.622	1.616
2						
3						
4						
5						
6						

1-D Measurements with Temperature Correction

Temperature correction requires that temperature is acquired together with the anemometer voltage. This is done by means of a temperature probe with an analog output connected to the A/D board and assigned as a probe in the System configuration. The CTA probe and the temperature probe should be mounted close to each other in the flow, so that they are both exposed to the same temperature.

Hardware list:

- 55P11 Probe
- 55H20 Probe Support
- 54T30 MiniCTA anemometer.
- 55P32 Thermistor Probe
- 54T40 Thermistor Amplifier
- 2 pcs. 9055A1863 Probe Cable, 4-m.
- Cables and Connector Box for the A/D converter board.
- PC with A/D board installed.

The basic procedure in the MiniCTA software is:

1. Assign the temperature probe in the System configuration.
2. Choose it as temperature probe.
3. Apply temperature correction to the Data conversion/reduction event.

System configuration

Configure the system with the hot-wire probe and the temperature probe. This is done by clicking on the Single sensor probe icon in the Configuration dialog box and select the 55P11 from the Single-sensor probe Icon and the 55P32 probes from the T,P... Icon, respectively. Choose OK. The dialog box closes.

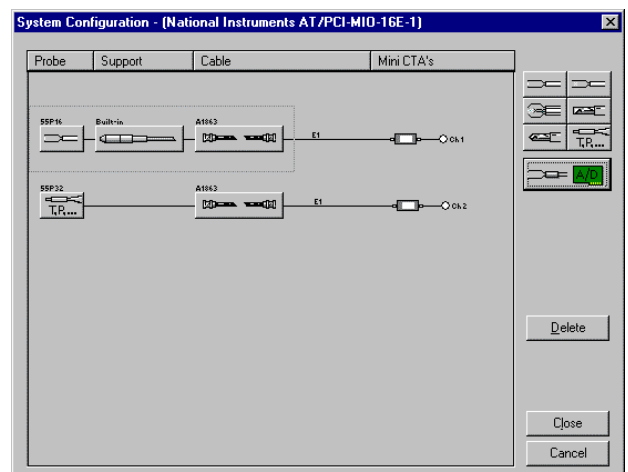
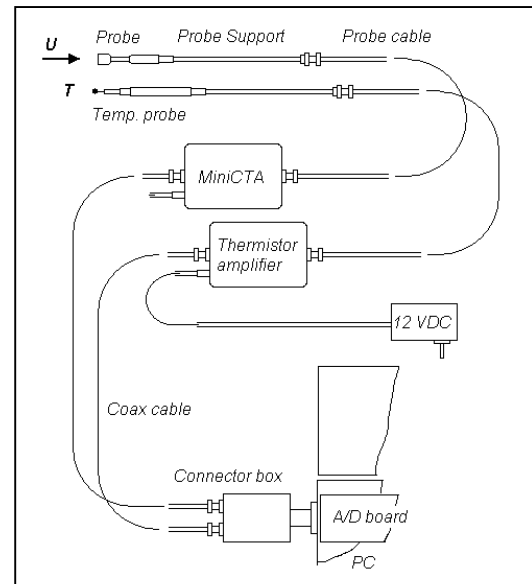

Select temperature probe:

When you close the Configuration dialog, you are prompted to select a temperature probe. Say Yes. Select probes dialog box opens.

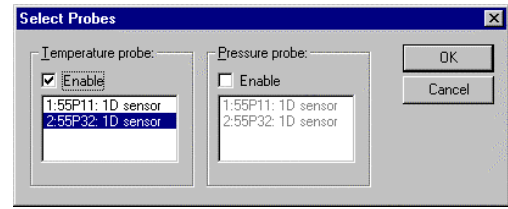

Click Enable and select probe 2: 55P32: 1D sensor. Click Ok to close the dialog box.

Hardware set-up and velocity calibration:

Perform hardware set-up and velocity calibration as described in Sample Project I and make both events default.

Now it is most important to enter the proper temperature in the hardware set-up.

The temperature can automatically be read as a Parameter during the calibration, if the temperature probe is placed in the flow next to the hot-wire probe.

Choose Parameter/Set-up/Temperature/A/D/ ch1 in the Calibration dialog box. Type in the linearisation (polynomial constants from the keyboard). For more details see *Chapter 5 Running the System*.

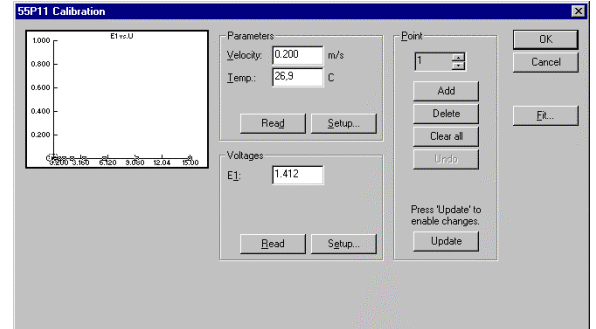

Important: Select Apply temperature correction in the Curve Fit dialog box, when you have finished the velocity calibration.

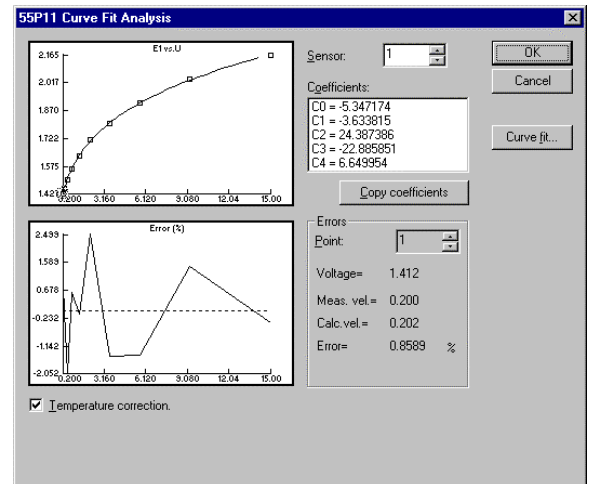

When you close the Calibration data sheet you are prompted create a data Conversion/Reduction. Say Yes to that and say Yes to the “Make the event default”. You will now have the two events marked with default stars listed in the Project Manager

Data conversion/reduction with temperature correction:

It contains all necessary information for performing temperature correction, linearisation and data reduction into mean and rms values. You need not make any further manipulations in it. To see what it looks like:

Open the Default Conversion/Reduction in the project manager (right mouse button). The Data conversion/reduction set-up dialog box opens. Close the dialog boxes by clicking on Cancel.

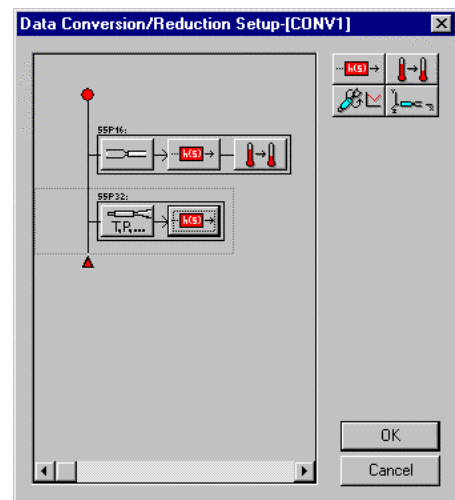

Run default set-up:

Run the default set-up as described in project I.

Run Data conversion and reduction:

Run the data reduction as described in project I.

Appendix II

Measurements with the Dantec Dynamics StreamLine Anemometer

Preparing for a StreamLine project:

This chapter directs you to the working platform of the StreamWare application software.

1. Create a folder for the database and project.

Switching on the StreamLine:

Note that you should **not** connect the power adaptor to the StreamLine, before the probe is connected and the decade is adjusted to proper overheat ratio.

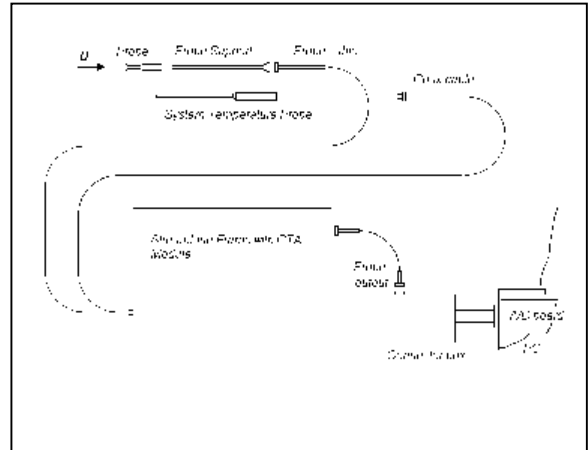

1-D Measurement in a Point

The anemometer output is connected to an input channel of the A/D board in the PC. It is assumed that the ambient temperature remains constant or nearly constant during the project.

Hardware list/Physical configuration:

- 55P11 Probe
 - 55H20 Probe Support
 - 9055A1863 Probe Cable, 4-m
 - 55C90 CTA Module (mounted in Frame)
 - 90H10 Calibration System (mounted in Frame)
 - 90N10 Frame with Temperature Transducer
 - 90B10 Null Modem Cable
 - Connector Box and Cable for the A/D converter board.
 - PC with A/D board installed
1. Connect PC and StreamLine frame to the power Line and leave both with power switched off.
 2. Connect first free PC comport, e.g. no 2, to the Serial Interface connector of the Frame by means of the Null Modem Cable.
 3. Connect the Analogue Output bushing no. 1 on the back panel of the Frame to the A/D board input channel no. 0 on the connector box for the A/D board with a 50 ohms BNC cable (max. 50 m).
 4. Connect Probe and Support with a 4 m Cable to the Probe BNC-connector on the CTA Module front plate.
 5. Place the probe in the calibrator with the wire in the center of the jet and aligned with the top surface of the nozzle.
 6. Connect the Temperature Probe to the Frame via its 4 m cable and place it close to the hot-wire probe.
 7. Switch power on to both systems.

Open StreamWare software:

Open StreamWare software by double clicking on the StreamWare Icon in the Program Manager. You are prompted to open or create a new database.

Create a Database

1. Choose Database/New from the File menu.

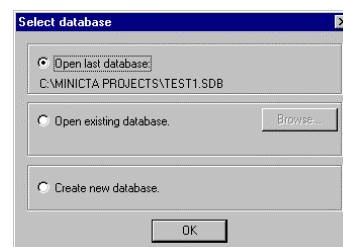

2. Select the folder that you already have created for the purpose and type in the name of your new data base, e.g. 1-wire.sdb.
4. Choose OK.

Create a Project:

You are now prompted to create a Project. Select Yes. A New Project dialog box opens.

1. Enter the name of your project and your initials in the Created by field.
2. Choose OK.

Define Devices:

You are now prompted to select an A/D board. Say Yes and the Device Library dialog box opens.

1. Select the A/D board that is installed in the PC.
2. Choose OK. A path is now made from the project to the translation driver.

System Configuration:

You are now prompted to configure the system. Select Yes and the System Configuration dialog box opens.

1. Click on the Frame Icon. Select Serial Port dialog box opens.
2. Select the COM1 in the Select Port list.
3. Choose OK. A Frame with the CTA Module and the Calibration Module is added to the Configuration map.
4. Click on Single Wire sensor probe Icon.
5. Select Probe, Support and Cable dialog box opens.
6. Select 55P11 Wire, 55H20 Support and a 1864 BNC/BNC Cable in the list boxes.
7. Choose OK. The Probe, Support and Cable are now added to the map. It is by default connected to the first CTA Module (no 1) and to A/D input channel 0.
8. Choose OK.

You are prompted to Initialize the hardware. Click OK.

Hardware Set-up

You are now prompted to define the set-up of the Hardware set-up of the CTA module. The dialog box shows the Configuration map once more but with command buttons for Overheat, Square Wave, Signal Conditioner and Startup.

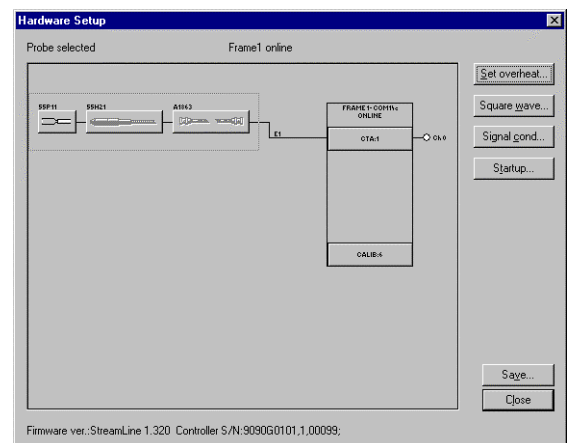
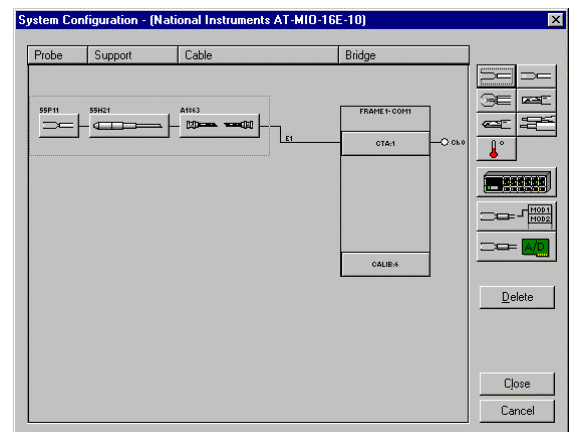
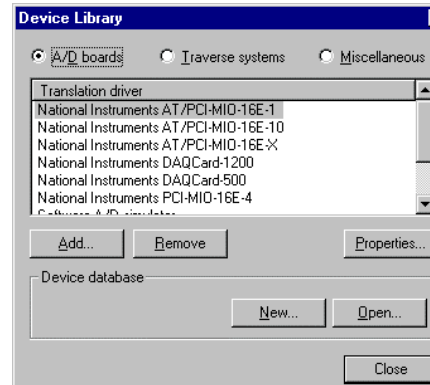
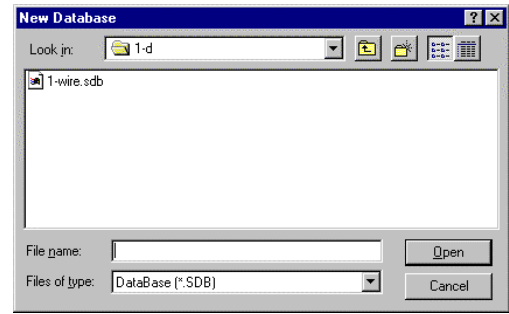

Overheat adjust:

First step is to measure the probe cold resistance and set the overheat.

Select the Overheat command. A Set overheat dialog box opens.

1. Click on Auto balance.
2. Total probe resistance and ambient temperature are now measured. Leads-, support- and cable resistances are subtracted from the total resistance providing the sensor cold resistance. The decade resistance is calculated and set in accordance with the overheat ratio.
3. Select Operate and click on the Start button ▶.



The CTA Module switches to operate and the bridge voltage is acquired together with the ambient air temperature (via the Controller in the Frame) and displayed.

Square wave test and Signal Conditioner:

The set-up of the servo amplifier in the CTA and of the Signal Conditioner are all Configuration Defaults taken directly from the Probe Library and needs not be optimized in this project. You can check the settings via the Square Wave and Signal Conditioner buttons in the Hardware set-up dialog box, before you close the dialog.

Close the Hardware set-up and save it as an Event:

Select Close.

You are now prompted to save this Hardware set-up. Say Yes, and a Save event dialog box opens. Type in an identification and say Yes again.

Make Default:

You are now prompted to make this Hardware set-up current Default. Say Yes.

Automatic overheat adjust:

A new prompt asks you, if you want to disable Automatic overheat adjustment. This feature measures the probe cold resistance and readjusts the decade, every time the default Hardware set-up starts. In this way the overheat ratio is kept constant independent of ambient temperature. Say No in order use this feature.

Velocity Calibration with StreamLine Calibrator

1. Select Velocity from the Set-up menu. The calibration and correction factors for your specific Calibrator are now loaded into the StreamWare software for use in the velocity calculation. This is indicated by the message box "Loading EProm data".
2. When finished, the Velocity Range dialog box opens.
3. Enter 1 m/s as min. and 20 m/s as max. velocity and 10 calibration points.
4. Select Apply temperature correction and Apply signal conditioner settings. This gives you the best accuracy, if the temperature changes during the calibration.
5. Select OK. The dialog box closes and you are prompted to install the Nozzle I.
6. If correct, select Yes.

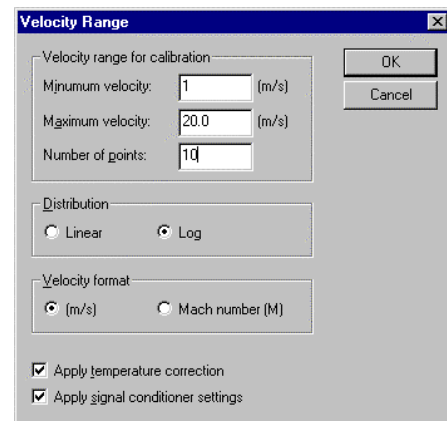

The Calibration dialog box opens.

Note that the default Hardware set-up automatically has been assigned to the calibration, and that this set-up was performed, before the dialog box opened.

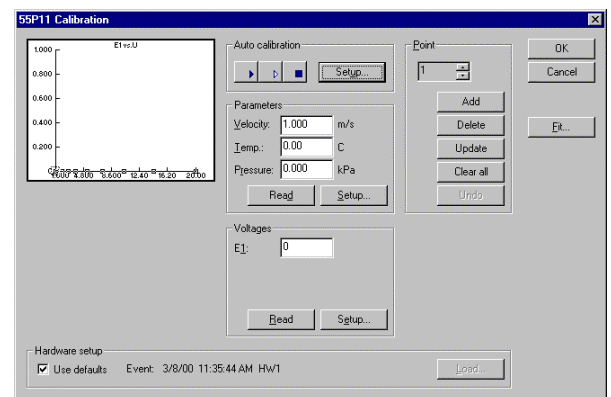

1. Select Start ►. An Auto calibration monitor window opens, which shows how the velocities are reached point for point. The calibration points are plotted into the graph in the Calibration dialog box.

When all points are done, the best curve fit (4th order polynomial) is automatically made and plotted into the calibration diagram.

2. Select the Fit command button. A Curve fit dialog box opens with linearization constants C0 to C4 and the error distribution. It also lists the temperature used for compensation of the probe voltages.

If you accept the results select OK. The dialog box closes and the calibration data are filled into the Calibration worksheet together with temperature and pressure.

1. Double-click in the Menu Control box in the upper left corner of the Worksheet window. A Save event dialog box opens.
2. Type in an identification and select OK. The dialog box closes and you are prompted to create a Conversion event on basis of the probe calibration.
3. Say Yes. A new Save event dialog box opens.
4. Type in an identification and select OK. The dialog box closes and you are prompted to make the Conversion event default. Say Yes.

A Calibration event and a Conversion event (both with the default stars) are added to the Project Manager.

You have now a complete Default set-up with a Hardware set-up and a Conversion set-up that can be used to acquire, linearize and reduce probe voltages into first and second order moments (mean and standard deviation).

Save the Calibration event and make Conversion event:

1. Double-click in the Menu Control box in the upper left corner of the data sheet window. A Save event dialog box opens.
2. Type in an identification and select OK. The dialog box closes and you are prompted to create a Conversion event on basis of the probe calibration.
3. Say Yes. A Save event dialog box opens.
4. Type in an identification and select OK. The dialog make the Conversion event default. Say Yes.

	U	E1	T(C)	P(kPa)	E1 corr	U1calc
1	0.200	1.412	26.800	0.000	1.412	0.202
2	0.323	1.444	26.900	0.000	1.444	0.322
3	0.522	1.486	26.700	0.000	1.486	0.510
4	0.843	1.546	26.900	0.000	1.546	0.850
5	1.363	1.614	26.800	0.000	1.614	1.367
6	2.202	1.698	26.900	0.000	1.698	2.252
7	3.557	1.783	26.900	0.000	1.783	3.500
8	5.747	1.888	27.000	0.000	1.888	5.665
9	9.284	2.014	26.900	0.000	2.014	9.424
10	15.000	2.143	26.800	0.000	2.143	14.942
11						
12						
13						
14						
15						
16						

A Calibration event and a Conversion/reduction event are added to the Project Manager.

Run Online:

You can now check the performance of the system in Online.

1. Choose Online analysis from the Run menu. Online dialog box opens.
2. Choose the Start button.

The Data display is now updated for each acquisition until you choose Stop or leave the dialog box.

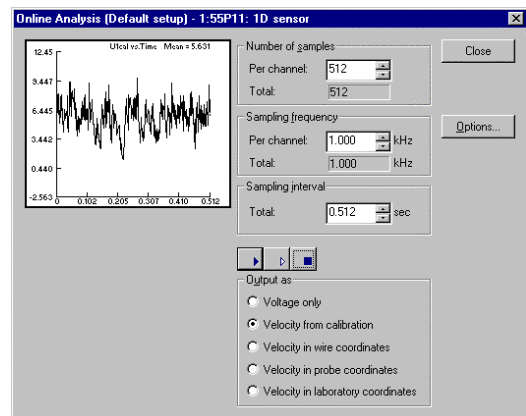

Default set-up:

The Default set-up consists of a hardware set-up and a loop defining probe positioning and data acquisition (sampling rate and number of samples). Finally the default conversion/reduction to be used on acquired data. In the present example you need not change anything in the default set-up.

Run Default:

You can store acquired data in a file by running Default instead of Online

1. Choose Run default set-up from the Run menu or click on the Acquire data Icon in the Main toolbar.
2. An Acquire data to disk event dialog box appears
3. Type in the identification for the Raw data event that will be the result of the default run.
4. Close the dialog box by choosing OK.

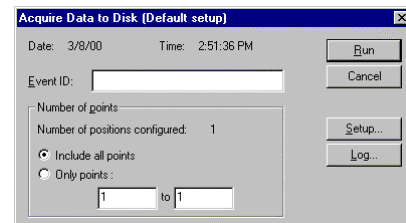

When finished, a Raw data record is added to the Project Manager.

Load Raw Data:

Raw data are stored in a file arranged with a database structure. In order to present the data, they have to be unpacked.

Point at the Raw data event in the Project Manager and click with the right mouse button and select Load. Raw Data Selection dialog box appears.

1. Choose Load.
A data sheet with the acquired data opens.
2. Choose Close. The dialog box closes and leaves the data sheet open.

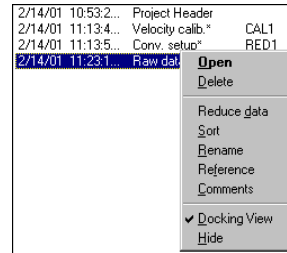

	TIME	E1
1	0.000	5.000
2	0.001	4.983
3	0.002	4.966
4	0.003	4.951
5	0.004	4.934
6	0.005	4.919
7	0.006	4.902
8	0.007	4.888
9	0.008	4.871
10	0.009	4.856

Present Data in a Graph:

1. Choose Graph from New Window in the Window menu or click on the Graph Icon in the Main toolbar.
Select Data Dialog box appears.
2. Select U1cal in the Data columns box.
3. Click on the Y--> button.
U1cal is now moved to the Y-arguments box.
4. Choose OK.

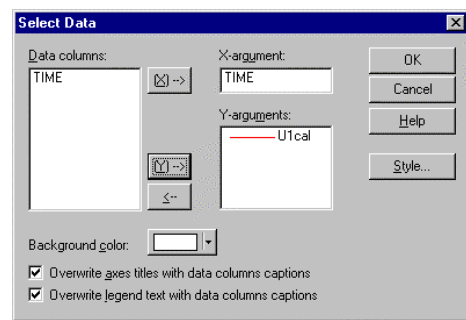

A Graph is now created with voltages as function of acquisition time.

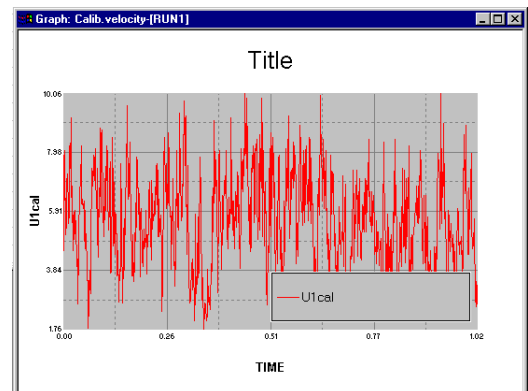

To Reduce Data:

1. Point at the Raw data event in the Project Manager and click with the right mouse button and select Reduce data.
A Save event dialog box opens. Note that the default Conversion event automatically will be used to convert and reduce the data.
2. Type in an identification and choose OK.
The Data reduction process is now carried out and a Reduced data event is added to the Project manager.

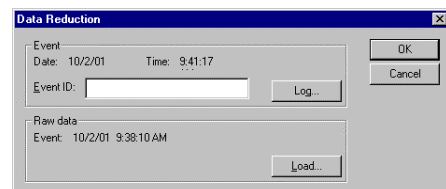

Load reduced data:

1. Point at the Reduced data event in the Project Manager and click with the right mouse button and select Load.
Data sheet showing the positions (0,0,0), the Umean and Urms. opens.

	X pos.	Y pos.	Z pos.	A pos.	U Mean	U RMS
1	0.000	0.000	0.000	0.000	5.622	1.616
2						
3						
4						
5						
6						

1-D StreamLine Measurements with Temperature Correction

This project demonstrates how to incorporate temperature correction into a project. For simplicity a project with only one single-sensor hot-wire probe has been configured. The procedure, however, is identical for any number of probes and for dual- and triple-sensor probes as well.

If a high absolute accuracy on mean velocity is required it is always recommended to include temperature correction in order to avoid systematic errors from even small fluid temperature variations. If not compensated for a temperature change of 1 °C gives approximately 2% error in velocity for a wire probe operated at the default overheat ratio 0.8.

The procedure is:

1. Choose a temperature probe.
2. Select flow medium and temperature loading factor.
3. Apply temperature correction to the Data conversion/reduction event.

Choice of temperature probe:

Temperature varies slowly during data acquisition:

If the temperature is expected to vary during the time it takes to perform a data acquisition, the analogue output from the System temperature probe connected to the StreamLine frame is used. It is connected to an A/D input channel and the probe is assigned as a separate probe in the System configuration. The temperature voltage is then acquired together with the probe voltage. Each probe voltage sample is then corrected with its own related temperature.

Temperature stays constant during data acquisition:

If the temperature is expected to stay constant during the time it takes to perform a set of data acquisitions, only one temperature value is needed. In this case the serial output from the System temperature probe can be used. It should then be programmed to write to a local variable, which is then selected as temperature input source. The temperature is polled via the serial interface prior to the acquisition of probe voltages via the A/D board. This must be defined in an Experiment set-up, as Default set-up does not accept local variables. All probe voltage samples are then corrected with the same temperature.

Fast temperature variations during data acquisition:

If fast temperature variations are expected, a separate fast temperature measuring device has to be connected to an A/D channel and assigned to the System configuration. The procedure is then the same, as if the analogue out from the System temperature probe was selected.

In any case it is important to mount the CTA probe and the temperature probe close to each other in the flow, so that they are both exposed to the same temperature.

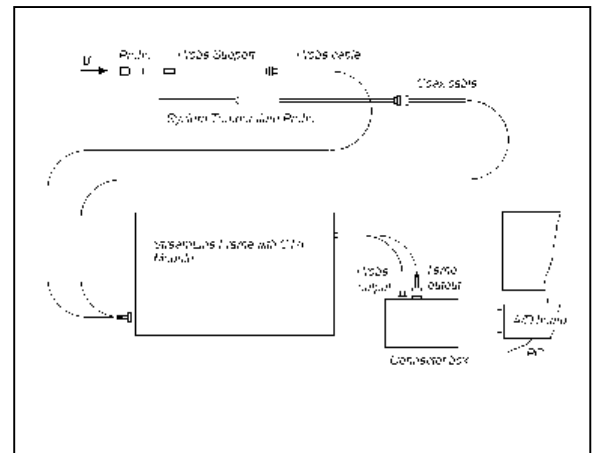

Temperature correction with System temp. probe via Temp. analogue out:

System configuration and selection of temperature probe:

1. Configure the system with the System temp. probe in addition to the hot-wire probe. This is done by clicking on the Temperature Probe icon in the Configuration dialog box. Close the Configuration dialog box.
2. You are now prompted to select a temperature probe. Select TEMP.
3. Choose OK. The dialog box closes.

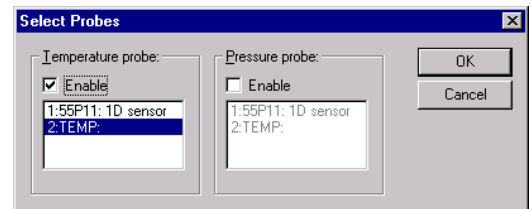
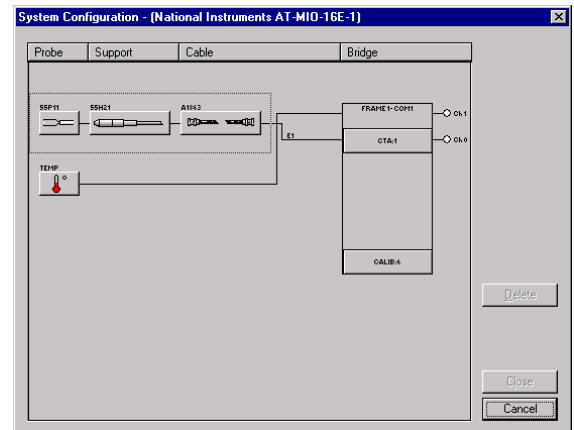

Select flow medium and temperature loading factor:

1. Choose the Physical Properties in the File/Libraries menu. A Physical properties dialog box opens.
2. Select Air, m=0.2 (a good default value for a wire probe) and click on the Select button.
3. Close. The selection is now loaded globally in StreamWare and will be valid next time you open StreamWare, even in another project.

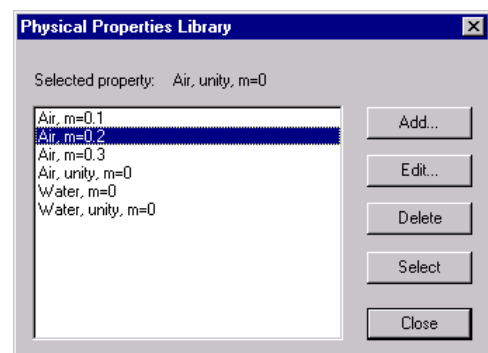

Hardware set-up and velocity calibration:

Perform hardware set-up and velocity calibration as described in the previous Sample project. Make both events default.

Important: Select apply temperature correction and apply temperature loading factor in the Velocity range dialog box in the velocity calibration.

Important: Select Apply temperature correction in the Curve Fit dialog box, when you have finished the velocity calibration.

When you close the Calibration data sheet you are prompted create a data Conversion/Reduction. Say Yes to that and say Yes to the “Make the event default”. You will now have the two events marked with default stars listed in the Project Manager

Data conversion/reduction with temperature correction:

It contains all necessary information for performing temperature correction, linearisation and data reduction into mean and rms values. You need not make any further manipulations in it. To see what it looks like:

Open the Default Conversion/Reduction in the project manager (right mouse button). The Data conversion/reduction set-up dialog box opens. Close the dialog boxes by clicking on Cancel.

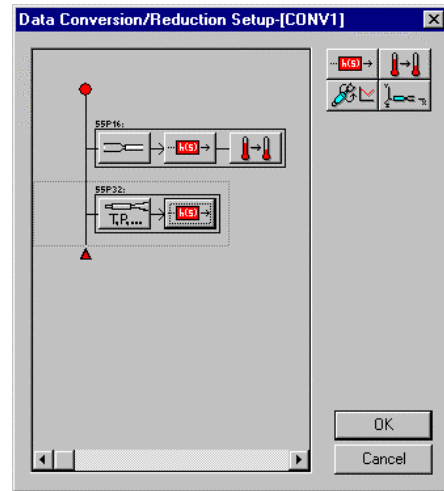

Run default set-up:

Run the default set-up as described in project I.

Run Data conversion and reduction:

Run the data reduction as described in project I.

Temperature correction with System temp. probe via Comport (serial interface):

System configuration:

1. Configure the system with only the hot-wire probe. Close the Configuration dialog box.
2. Choose OK. The dialog box closes.

Note: A temperature probe should not be selected in this case. Instead a local variable has to be selected in the Data reduction and in the Data flow dialogs.

Defining local variable:

Here you give proper name and unit to the local variable that is going to contain the temperature information.

1. Choose Local variables from the Project menu. Local variable dialog box opens.
2. Type in Temp. and C in variable A.
3. Close the dialog box

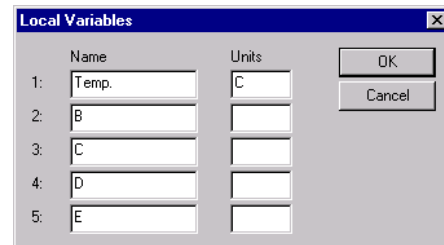

Hardware set-up and velocity calibration:

Perform hardware set-up and velocity calibration as described in Sample project I. Make both events default.

Important: Select apply temperature correction and apply temperature loading factor in the Velocity range dialog box in the velocity calibration.

Create Data conversion/reduction with temperature correction:

1. Choose Conversion/reduction in the Set-up menu. A Data conversion/reduction set-up dialog box opens.
2. Select the hot-wire probe (by clicking to the left of the probe in the diagram). A frame is drawn around the probe.
3. Click on the Temp. function button in the toolbox. The button is copied into the probe frame.
4. Click on the Temp. comp. button in the frame. A Temperature correction set-up dialog box opens, where you select the local variable that will contain the temperature information.
5. Close the dialog box.
6. Click on the Transfer fct. button in the frame. A Transfer function dialog box opens, where you select the calibration event.
7. Close the dialog box.
8. Double click on the Probe button. A Probe conversion options dialog box opens.
9. Click on the Options button and check that Temperature correction is selected.
10. Close the dialog boxes and save the Data conversion/reduction event and make it default.

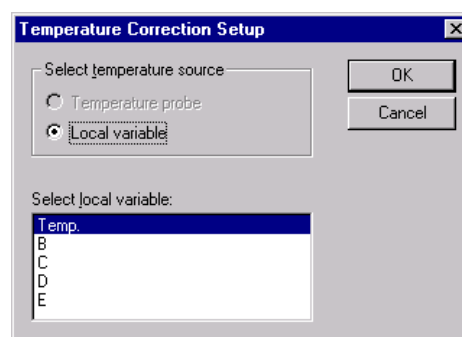
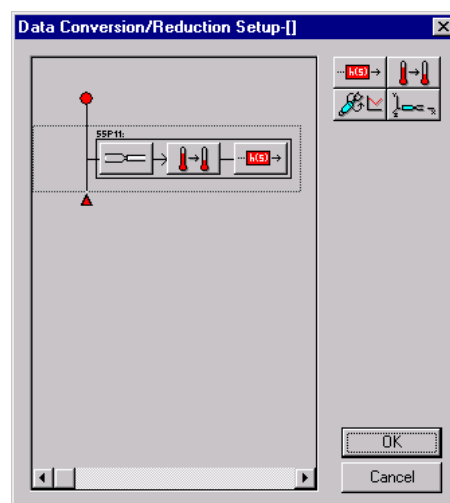

Acquire and reduce Data:

Run the data acquisition and reduction as described in the previous sample project.

Temperature correction with External temp. probe via A/D channel:

For applications with fast temperature fluctuations, where the System temperature probe is too slow. Any fast thermometer, e.g. a set of small thermocouples, with an analogue output can be used.

Adding the temperature probe to the Probe Library:

Open the miscellaneous probes and add the temperature probe. As a minimum you must give it a name and fill in 1 for number of sensors. Remember to enter the calibration constants that converts volts to °C in the Coefficients dialog box.

System configuration:

Open the system configuration dialog box and add the frame and the hot-wire probe. Then click on the Misc. probe button and select the temperature probe. It will then be connected to the next A/D channel in the diagram as an external probe.

Further procedure:

The procedure including selection of the temperature probe is now identical with the previous project where temperature correction was made using the System temperature probe via the analogue temp. out on the frame.