

# Human kinship, from conceptual structure to grammar

Doug Jones

Department of Anthropology, University of Utah, Salt Lake City, UT 84112  
douglas.jones@anthro.utah.edu

**Abstract:** Research in anthropology has shown that kin terminologies have a complex combinatorial structure and vary systematically across cultures. This article argues that universals and variation in kin terminology result from the interaction of (1) an innate conceptual structure of kinship, homologous with conceptual structure in other domains, and (2) principles of optimal, “grammatical” communication active in language in general. Kin terms from two languages, English and Seneca, show how terminologies that look very different on the surface may result from variation in the rankings of a universal set of constraints. Constraints on kin terms form a system: some are concerned with absolute features of kin (sex), others with the position (distance and direction) of kin in “kinship space,” others with groups and group boundaries (matrilines, patrilineages, generations, etc.). Also, kin terms sometimes extend indefinitely via recursion, and recursion in kin terminology has parallels with recursion in other areas of language. Thus the study of kinship sheds light on two areas of cognition, and their phylogeny. The conceptual structure of kinship seems to borrow its organization from the conceptual structure of space, while being specialized for representing genealogy. And the grammar of kinship looks like the product of an evolved grammar faculty, opportunistically active across traditional domains of semantics, syntax, and phonology. Grammar is best understood as an offshoot of a uniquely human capacity for playing coordination games.

**Keywords:** cognitive anthropology; conceptual structure; coordination games; evolutionary psychology; grammar; kinship; kin terms; language evolution; Optimality Theory (OT); recursion

## 1. Introduction

This article addresses a longstanding puzzle in the human sciences: Kinship and language, very different in content, are intriguingly similar in form. Kinship has to do with aunts and uncles, matrilineages and patrilineages, and ascending and descending generations, while linguistics has to do with phonemes and syllables, morphemes and word classes, and heads and phrases. But kinship and language are similar in their combinatorial structure, pointing toward general principles of cognition or communication at work in both cases (Kroeber 1909, Lévi-Strauss 1963).

The parallels between kinship rules and language rules were the subject of pioneering work several decades ago, in the heyday of structural linguistics and structuralism. Especially in the area of kin terminology, and especially from the 1960s to the 1970s, researchers demonstrated that the classification of kin reflects not just social facts, but also cognitive and linguistic principles. Cross-cultural regularities in kin terminology were documented, comparable to regularities in color terminology (D’Andrade 1971; Greenberg 1966; 1975; 1990; Nerlove & Romney 1967), and an assortment of formal methods was devised to analyze systematic variation and universals in kin terminology (Buchler & Selby 1968; Goodenough 1965; Lounsbury 1964a; 1964b; Romney & D’Andrade 1964; Scheffler 1968; Scheffler & Lounsbury 1971; Wallace & Atkins 1960).

But intellectual fashions have changed since then. In spite of important advances (Gould 2000; Hage 1997; 2001; Hirschfeld 1989; Kronenfeld 1996; 2009; Leaf 2006; Lehman 1993; 2001; Read 1984; 2001a; 2001b), the study of kinship, language, and cognition now finds

itself in a marginal position in anthropology and cognitive science. Cultural anthropology, with some exceptions, has grown increasingly committed to cultural particularism, and increasingly divorced from developments in cognitive science. The minority of anthropologists who apply evolutionary theory to kinship mostly have not investigated its cognitive aspects. (On the “fall of kinship” in anthropology, see Sousa 2003 and commentators, and Shapiro 2008.) Meanwhile, as linguistics has grown increasingly specialized – and especially as syntax has moved to a dominant position in the field – some earlier connections with other areas of inquiry have weakened.

In this article, however, I argue that the classic topic of kinship and language deserves a fresh look in the light of recent progress in linguistics and cognitive science – and, in turn, that the study of kinship is relevant to current debates about mind and language. The rest of this section introduces advances in two areas – the exploration of conceptual structure at the interface between semantics and cognition, and the development

DOUG JONES is Associate Professor of Anthropology at the University of Utah and author of *Physical Attractiveness and the Theory of Sexual Selection* (1996, University of Michigan, Museum of Anthropology) and co-editor (with Bojka Milicic) of *Kinship, Language and Prehistory* (2010, University of Utah). He is interested in how the social anthropology of kinship relates to recent advances in the cognitive sciences and evolutionary theory. Jones is also currently doing research on the cognitive anthropology of race in Brazil.

of a new approach to rules of language called optimality theory – and previews how they apply to kinship.

*Conceptual structure.* The study of human cognition has received a major boost from the realization that there are two distinct levels of language – ordinary and VIP, as it were – which differ both in linguistic behavior and in meaning (Grimshaw 2005; Jackendoff 1983; 2002; Pinker 1989; 2007; Talmy 2000a). The first, open-class or lexical, level includes most nouns and verbs. The number of open-class forms in any language is very large, and virtually any imaginable concept can receive an open-class form.

The second, closed-class or grammatical, level is a more exclusive club. Forms at this level include prepositions like *in* and *on*, demonstratives like *this* and *that*, inflections like the plural *-s* and past tense *-d*, and word classes like mass noun and intransitive verb (but not specific instances of nouns or verbs). Within languages, closed-class forms are limited in number: Compare the number of prepositions, demonstratives, tenses, and word classes in English with the number of nouns and verbs. Closed-class forms are also restricted in the range of meanings they bear. Across languages, some of the distinctions that regularly make it into closed-class forms are: singular and plural, bounded and unbounded, figure and ground, near and far, present and past, unmovable/inalienable and movable/alienable, and human and nonhuman. But many more semantic distinctions – some quite important – are seldom or never registered in closed-class forms, including odd and even, legal and illegal, and absolute size or duration (e.g., more and less than *x* feet long or *t* years old).

The distinction between two levels of language is not only interesting in its own right, but also potentially important for investigating cognitive universals. Suppose, as many lines of evidence suggest, that in learning about words and the world, people draw not just on perceptual data but also on an inventory of innate concepts. Then open-class and closed-class forms reflect this inventory in different ways. With open-class forms, universal concepts are hooked up with one another to yield a virtually unlimited array of culturally variable compound ideas (Wierzbicka 1996). With closed-class forms, the internal “atomic structure” of universal concepts shows up in regularities in how related conceptual primitives are merged or distinguished.

Two findings stand out from the study of closed-class linguistic forms. First, forms carve out a small number of semantic fields, including space, time, causation, mental states, and social relations like possession. Second, there are close parallels across fields. Specifically, nonspatial fields seem to borrow much of their organization from the conceptualization of objects and motions in space. In language after language, time is treated as a more abstract version of space, change in state as an abstract kind of movement, causation as an abstract push, possession as abstract location, and so on (Bierwisch 1996; Hurford 2003; Jackendoff 1983; Pinker 1989; 2007; Talmy 2000b).

*Optimality Theory.* While different linguistic domains – semantics, phonology, morphology, syntax – have their own organizing principles, there are also general principles of rule-governed “grammatical” communication operating across domains. Such at least is the implication of research in Optimality Theory (OT), a powerful new

approach to rules of language, originally developed in phonology but apparently of much wider application (Archangeli & Langedoen 1997; McCarthy 2001; Prince & Smolensky 2004/1993).

OT doesn’t say what the rules of language are – rules differ among linguistic domains – instead, it describes how rules interact. According to OT, rules, or constraints, don’t actively transform linguistic representations but act as filters on randomly generated variation, with each constraint weeding out variants that violate it. Constraints may be mutually inconsistent, so grammars manage trade-offs between conflicting constraints through constraint ranking. Constraints are put in rank order, with each constraint strictly dominating lower ranking ones: One violation of a constraint outweighs any number of violations of all lower ranking constraints. OT covers cross-linguistic universals and variation in grammar in a unified framework: To a first approximation, languages all use the same constraints but differ in their constraint rankings.

OT has inspired large body of research: As of this writing, one major online resource, the Rutgers Optimality Archive (roa.rutgers.edu), has 1,069 articles on file. Yet in some ways OT is still finding its place in linguistics. For example, recent theories of language evolution (Hauser et al. 2002; Hurford 2007; Jackendoff 2002) have nothing to say about the phylogenesis and adaptive significance of OT. We may get a better idea of the nature and potential of the theory by comparing it to Utility Theory (UT) in economics. Both UT and OT are theories of constrained optimization. They posit that people mentally search a large space of possibilities to discover an optimum, either an optimal basket of goods or an optimal linguistic output. *Optimal* doesn’t mean perfect. It means doing as well as possible in the face of trade-offs between conflicting constraints. Yet optimization works differently in UT and OT (Prince 2007; Smolensky & Legendre 2006). In standard UT, trade-offs and potential outcomes vary quantitatively, so economic optimization involves finding maxima of continuous functions. In OT, rules are ranked rather than numerically weighted, so grammatical optimization is discrete and combinatorial. UT and OT thus seem to cover two contrasting macro-domains of human behavior, the economical and the grammatical.

Both theories of conceptual structure (as revealed by closed-class forms) and OT approaches to grammar apply to kin terminology – or so I argue here. The surface complexity of kin terminology across cultures results from the interplay of a conceptual system adapted for representing kinship and other social relationships, and a “grammar” system bridging conceptual structure and language with principles of optimal communication, as laid out in Figure 1. The rest of this article works its way upstream through this figure, first laying out the principles governing kin terminology (sect. 2 to 4) and then advancing some hypotheses about the conceptual structure of kinship and the human grammar faculty (sect. 5).

The specific goals of this analysis are to offer an account of why kin terminologies have the shapes they have, and, conversely, to use constrained variation in kin terminologies as a window on two cognitive domains. What is meant by the “shape” of kin terminologies should become clearer as the exposition proceeds and I develop an input-output account of kin terms: It includes both

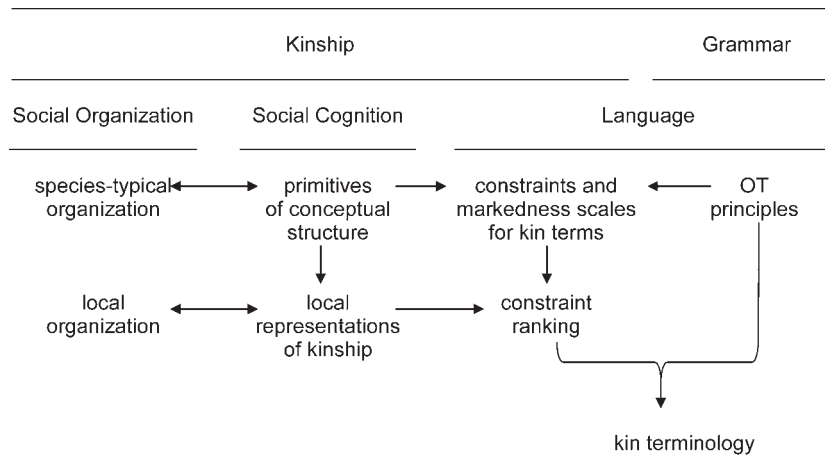

Figure 1. From conceptual structure and grammar to kin terminology. The top row shows human universals; the bottom row shows cultural variables. Arrows show causal links.

semantic contrasts among categories and the regularities that account for how contrasts get extended out to ranges of kinfolk, but it does not cover everything that people think about kinship or all the ways people use kin terms to talk or think about other things in the world. It is about the structure, rather than the content, of kin terms.

Limitations of space mean that some important topics get short shrift here. First, I touch on connections between social organization and kin terminology – see the lower and left areas of Figure 1 – but do not explore them at length. I believe the evidence is strong that kin terminology reflects, but doesn't just reduce to, sociology; the focus here is on cognition and language. Second, I bring up alternative formal approaches to kin terminology where relevant, but without extended, side-by-side exposition and comparison; there is an outline of the relationship between this work and alternative approaches at the end of the next section. Finally, this article employs only as much of the formidable technical apparatus of kinship theory and Optimality Theory as seems appropriate to illustrate important points. Other publications (Jones 2003a; 2003b; 2004; 2010) include more technical discussion, including kin term derivations using OT “tableaus,” and supporting data.

## 2. Optimal kin terms, English and Seneca

### 2.1. English and Seneca

This section and following ones turn to two kin terminologies, American English (henceforth English) and Seneca, to illustrate basic principles. English kin terms are probably familiar to most readers (Goodenough 1965). The rules governing English kin terms are similar to those in most modern Western European languages and Japanese. Seneca is another matter. The Seneca Indians are one of the original five (later six) nations in the Iroquois League of modern upstate New York. The comparison of English and Iroquois provided one of the earliest demonstrations that kin terms in different languages may be organized on very different lines (Morgan 1954/1851; 1997/1871; Trautmann 1987).

Portions of the two terminologies are shown in Figure 2. The figure gives terms in both languages for types of

siblings, parents, aunts, uncles, and cousins relative to an anchor called Ego. Terms for distant generations (grandparents, etc.), descending generations (niece, grandson, etc.) and affines (wife, brother-in-law, etc.) are omitted. There is a strong consensus on terms among speakers of each language. Spelling of Seneca terms follows Morgan, sacrificing accuracy for accessibility.

We may note several things about Figure 2. Not only do English and Seneca of course have different words for kin, they also have different kin terminologies – two kin types called by different terms in English may be called by a single term in Seneca, and vice versa. Both terminologies are regular: In neither case are terms scattered randomly around the diagram. For example, English systematically labels every Parent's Sibling's Child a *cousin*. Seneca is just as systematic in its own way. Cousins related through parents of opposite sex ('cross cousins' in anthropological jargon) are *ahgareseh*, while cousins related through parents of the same sex ('parallel cousins') are equated with appropriate sibling types. (In this article, capitals indicate kin types, italics indicate native-language kin terms, and single quotation marks indicate glosses of kin terms.)

Some distinctions are quite important in both languages: Kin in different generations are terminologically separate for all kin types shown. Other distinctions are moderately important: In both languages a sex distinction holds for parents' siblings and siblings, but not for cousins (except where cousins are equated with siblings in Seneca). Some distinctions are more important in one language than the other: English cares more about the distinction between near and distant kin than Seneca, while Seneca, but not English, distinguishes some kin by whether they are parallel or cross, and by relative age.

Some aspects of Seneca kin terminology are probably related to Seneca social organization. The Seneca were matrilineal, organized in kin groups based on descent through the female line (Morgan 1954/1851; Palmer 1934). Small-scale descent groups, or lineages, were associated with residence in longhouses. The core of each lineage was a group of related women. A man left his family and went to live with his wife's kin when he married; a woman continued to live with her mother and sisters and their dependent children and husbands. Inheritance and succession to office

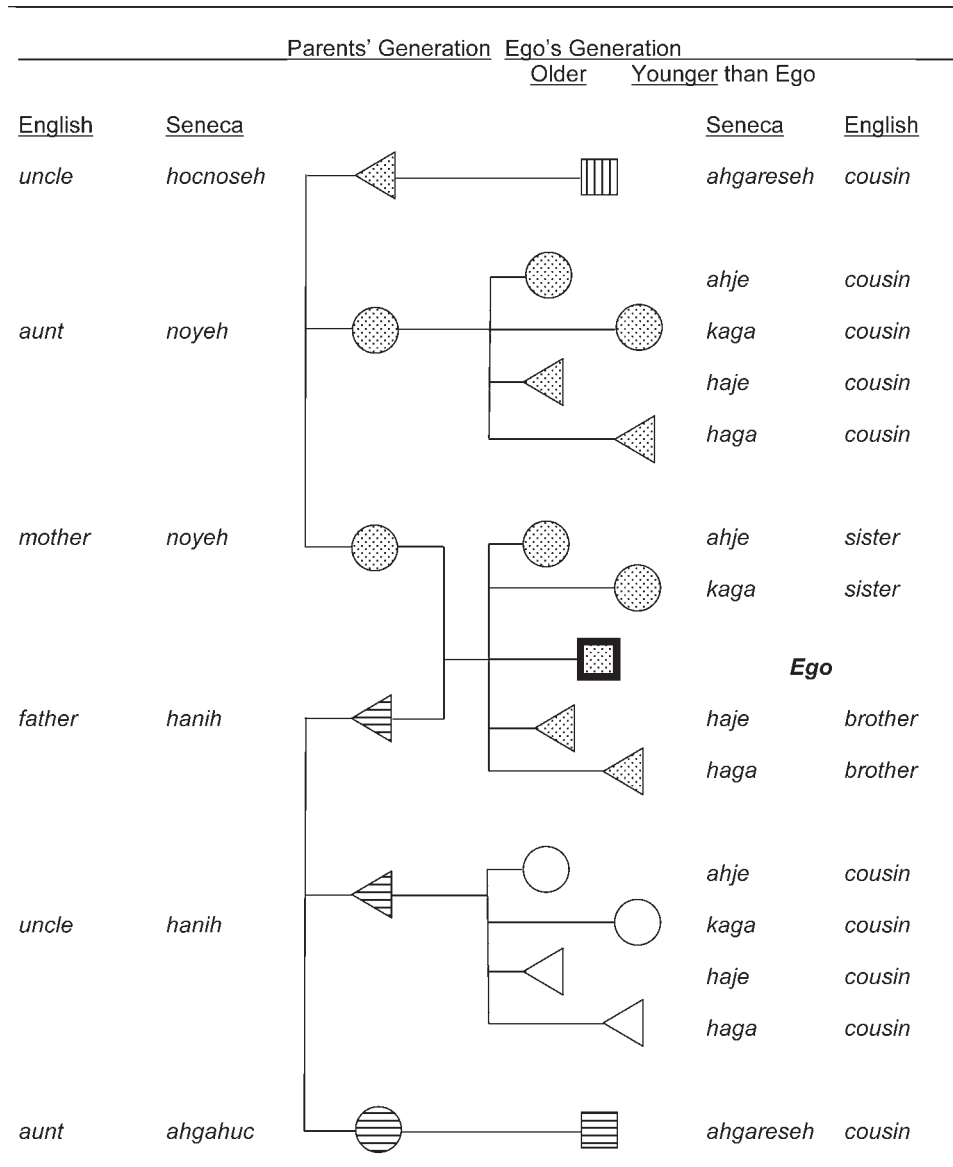

Figure 2. Some English and Seneca kin terms, in relation to **Ego** (center of chart). Circles are females, triangles males, squares either sex. Relative age (older or younger than Ego) is shown for siblings and some cousins. Shading indicates different lines of descent through females (matrilines).

were matrilineal as well: not from father to son, but from a woman to her daughters, sisters, and sisters' daughters, and from a man to his brothers and sisters' sons. On a larger scale, each lineage belonged to one of eight named clans, with multiple lineages in each clan. Clans were exogamous (out-marrying), so that a woman and her husband came from different clans. As a result, Ego belonged to the same clan as his or her Mother, Mother's Sister, and all their children, while Ego's Father along with Father's Sister and her children belonged to another clan, as did the children of Mother's Brother.

### 2.2. Applying OT

Social factors like those above probably influence English and Seneca kin terminologies, but the terminologies are also governed by cognitive/linguistic principles. Here, I treat these in the framework of Optimality Theory. We begin with two lists of the constraints governing a portion

of kin terminology in English and Seneca. The same constraints appear in both lists, but in different order.

English	Seneca
DISTINGUISH GENERATIONS	DISTINGUISH GENERATIONS
DISTINGUISH DISTANCE	DISTINGUISH MATRIKIN
MINIMIZE COUSINS	MINIMIZE COUSINS
DISTINGUISH SEX	DISTINGUISH SEX
MINIMIZE PARENTS' SIBLINGS	MINIMIZE PARENTS' SIBLINGS
MINIMIZE SIBLINGS	DISTINGUISH GRADE
DISTINGUISH GRADE	MINIMIZE SIBLINGS
DISTINGUISH MATRIKIN	DISTINGUISH DISTANCE

The constraints are of two kinds. One kind, taking the generic form **DISTINGUISH FEATURE**, requires that kin

terms be multiplied as necessary to preserve information about distinctions such as generation, genealogical distance, sex, and so on. The other kind, of the generic form MINIMIZE KIN TYPE, requires that speakers use as few terms as possible for kin types such as Cousin, Parent's Sibling, and so on. Clearly these requirements for maximizing information and minimizing terms cannot be satisfied simultaneously. Instead each language makes a conventionalized trade-off between constraints by ranking them, with each constraint taking strict precedence over lower-ranking constraints. The constraint ranking defines the grammar of each language, establishing a shared code among speakers and listeners.

Consider how the left-hand ranking governs the categorization of, say, an Older Mother's Brother's Son (i.e., older than Ego). In English, this relative is merged with other parent's sibling's children, as *cousin*. But there are other possibilities. The kin type could be merged with Parent's Brother or with Older Brother. It could receive its own separate expression, or be categorized as 'older cousin,' sex unspecified. In OT, all these possibilities – all possible distinctions and equations involving a given kin type – are evaluated, in parallel, by the first constraint. Only those candidates that incur the fewest violations of the constraint survive; the rest are eliminated. The survivors are then filtered through the second constraint, and so on, until just one optimal categorization survives.

The first constraint in the English ranking, DISTINGUISH GENERATIONS, demands that different generations of kin be kept terminologically distinct. This eliminates any terminology that puts cousins in the same category as uncles. The second constraint, DISTINGUISH DISTANCE, demands that near and distant kin be distinguished. This eliminates any terminology equating cousins and siblings. The third constraint, MINIMIZE COUSINS, would be perfectly satisfied if English had no cousin terms. But the two preceding constraints have eliminated this possibility. Instead MINIMIZE COUSINS is partially satisfied: it selects as the winning candidate a single 'cousin' term, with no distinctions by sex or age. The effacement of sex and age distinctions violates two other constraints, DISTINGUISH SEX and DISTINGUISH GRADE. (The latter enforces distinctions related to seniority and social rank, including relative age.) But these rank lower than MINIMIZE COUSINS, so the violations are moot. With the constraints acting in the order given, 'cousin' – equivalent to 'parent's sibling's child' – is the optimal output.

Next, consider parents' siblings in English. Since DISTINGUISH DISTANCE and DISTINGUISH SEX outrank MINIMIZE PARENTS' SIBLINGS, these relatives are distinguished, from parents, and by sex, as *aunt* and *uncle*. English sibling terms are similar. DISTINGUISH SEX ranks higher than MINIMIZE SIBLINGS, which ranks higher than DISTINGUISH GRADE, so English has two sibling terms, *brother* and *sister*, distinguished by sex but not relative age.

Seneca cousin and sibling terms follow a different logic. The high rank of the DISTINGUISH GENERATIONS constraint means that Seneca, like English, avoids cross-generation equations. But the next constraint on the list, DISTINGUISH MATRIKIN, does something else. This constraint dictates that relatives in cross or adjacent matriline be distinguished, so that cross cousins (stripes in Fig. 2)

are distinguished from parallel cousins and siblings (stippled or white). But the constraint allows kin in the same matriline, or nonadjacent matriline, to be merged. (See next section for more discussion.) In combination with MINIMIZE COUSINS this results in the Seneca combination of one term for "cross cousin," and the equation of parallel cousins with siblings.

Parents' siblings in Seneca follow a similar pattern. Father's Sister and Mother's Brother get separate terms from other aunts and uncles, distinguished by sex, reflecting the high rank of DISTINGUISH MATRIKIN and DISTINGUISH SEX. Mother's Sister and Father's Brother are equated with the parents in their respective matriline, Mother and Father, because MINIMIZE PARENTS' SIBLINGS trumps DISTINGUISH DISTANCE, the constraint that keeps parents' siblings and parents apart in English. Finally, the ranks of DISTINGUISH SEX, DISTINGUISH GRADE, and MINIMIZE SIBLINGS, result in siblings (and parallel cousins equated with siblings) being distinguished both by sex and relative age.<sup>1</sup>

### 2.3. Generating variation

There are many other ways of classifying cousins and other kin. For example, French makes a sex distinction among cousins that English and Seneca don't. Consider the French movie title *Cousin, Cousine*: A close translation, following anthropological convention, would be Parent's Sibling's Son, Parent's Sibling's Daughter. But the English language remake of the movie was instead entitled *Cousins*, losing the racy cross-sex pairing of the original.

Suppose, in the English constraint ranking above, we move DISTINGUISH SEX up one place. With this constraint now outranking MINIMIZE COUSINS, the new ranking generates a kin terminology with a sex distinction among cousins as well as siblings. This is how Optimality Theory handles variation in kin terminology. The same constraints, in two different rankings, generate English and Seneca terminologies. A small change in the English ranking generates another terminology, and further permutations generate many more. With the right constraint rankings, separate cousin terms disappear completely, and Cousin merges with other kin types, in the same or different generations. With other rankings, all siblings are covered by one generic term, or they are distinguished by relative age but not by sex. Each of these possibilities is found, fairly frequently, among the world's languages (Murdock 1970; Nerlove & Romney 1967).

Kin terminology is prodigiously variable. Introductory treatments of the topic often limit themselves to listing a few major typological variants of, say, cousin terminology: Thus English and French have "Eskimo"-style cousin terms, while Seneca is "Iroquois" (Fox 1967; Stone 2000). But no list of manageable size can really accommodate the complex permutations and interdependencies involved: For example, English resembles Seneca, not French, in ignoring sex distinctions among cousins. Yet kin terminology is also highly constrained. Languages around the world have independently hit on similar patterns, while largely steering clear of other imaginable possibilities. Kin terminologies are not perfectly regular, but overwhelmingly so (D'Andrade 1971; Nerlove & Romney 1967).

OT offers an account of variation and universals in kin terminology, as the outcome of variable rankings among universal constraints. OT is a generative theory, going beyond surface generalizations and one-culture-at-a-time formal analysis to show how interaction between principles generates terminologies, without overgenerating and producing rare or nonexistent terminologies.

In kin terminology, as in phonology, research in the framework of OT builds on and synthesizes previous work. The theory I present here very much depends on previous theories of kin terminology, each of which, I suggest, elaborates on a different aspect of kin terminology to offer a partial view of the subject. The organization of terminology around distinctive features is the starting point for componential analysis (Goodenough 1965; 1967). Markedness and prototype effects receive particular attention in structural linguistic analysis (Greenberg 1966; 1975; 1990; Hage 2001). The extension of kin terms to genealogically distant kin is the basis of reduction rules (Lounsbury 1964a; 1964b; Scheffler 1968). And the abstract algebra of kin categories, including identity elements, reciprocals, relative products, and abstract symmetries, is where kinship algebra begins (Read 1984; 2001a). Each of these receives some attention in the rest of this paper: distinctive features in section 3.1, markedness in 3.2, genealogical extension in 4.1, and formal relations between categories, and their relation to genealogy, in 5.2.

Yet each of these alternative approaches, I would argue, has its limitations. Componential analysis is particularly successful in discovering semantic contrasts among kin terms, less successful in accounting for where contrasts are active and inactive, and how contrasts are extended to more distant relations. Markedness theory is a set of observations, not a generative theory. Reduction rules and kinship algebra handle terms for more distant relatives in a more natural, less post hoc way than componential analysis, but don't offer much explanation of why particular reduction rules or structural equations operate, and not others. The rest of this article will suggest how these limitations can be overcome in the framework of Optimality Theory.

### 3. Constraints and scales

The previous section introduced several constraints as needed to illustrate some basics of Optimality Theory. This section proceeds more systematically, proposing a set of violable constraints on kin terminology, and associated scales limiting allowed permutations in constraint rankings. The list may be incomplete, and some of the rules may turn out to need reformulation, but this work has advanced far enough to allow this conclusion: Constraints and scales are not a hodge-podge; they form a system.

This system is set out in Figure 3. The left-hand column gives seven faithfulness constraints. The right-hand column lists three markedness scales. The middle column diagrams these: Dotted lines show how faithfulness constraints distinguish kin types, and arrows point toward less marked types. The figure is divided horizontally into three parts. The top part shows a nonrelational, absolute distinction, the sex distinction. The middle part shows constraints and scales concerned with the position – the genealogical distance or direction – of kin types relative to Ego. Finally, the bottom part shows constraints and scales concerned with how the nexus of kinship can

be cut to yield bounded groups, such that a kin type may belong to Ego's in-group, or to an out-group.

I review constraints and scales following.

#### 3.1. Seven faithfulness constraints

Kin terms typically fall into natural classes, defined by the presence or absence of distinctive features (Goodenough 1965; 1967). This property of kin terminologies is accommodated in OT by faithfulness constraints, which forbid terminological mergers of kin types differing with respect to some feature. Here I introduce a set of faithfulness constraints, and briefly contrast them with some traditional distinctive features.

1. **DISTINGUISH SEX.** A kin type's sex is not a relationship, but an absolute category. You are a parent or a younger sibling in relation to someone, but a female or a male on your own. All kin terminologies make some absolute sex distinctions, which can be handled by a **DISTINGUISH SEX** constraint.

2. **DISTINGUISH DISTANCE.** A distance function for consanguineal kin types can be defined as follows: Let a consanguineal chain consist of (1) any number of parent types, followed by (2) at most one sibling type, followed by (3) any number of child types. Formulas fitting this format include Younger Brother, Father's Daughter, Mother's Sister, and Older Mother's Mother's Brother's Son's Son. Count as one link each of the following: Parent, Sibling, and Child, except that Parent's Child, if present, counts as one link not two. Then Older Brother and Father's Daughter are one link from Ego, Mother's Sister two links, and Older Mother's Mother's Brother's Son's Son five links. **DISTINGUISH DISTANCE** is violated when kin at different consanguineal distances are equated with one another.

3. **DISTINGUISH GRADE.** Some kin types are fully reciprocal: if A is grandparent to B, then B is always grandchild to A, and the converse. Some kin types are partially reciprocal: if A is aunt to B, then B is sometimes niece to A, and the converse, depending on their sex. Full and partial reciprocals are equidistant from Ego, so the previous constraint, **DISTINGUISH DISTANCE**, does nothing to distinguish them. Instead another constraint, **DISTINGUISH GRADE**, rules out any equation of reciprocals.

But **DISTINGUISH GRADE** does more than this. It is concerned more generally with differences in grade or rank, distinguishing kin who outrank Ego from those outranked by Ego. The directed axes along which kin may rank higher or lower than Ego include:

- |  |   |
|--|---|
| • Relative age                             | Older Sibling vs. Younger Sibling, for example,                                     |
| • Ascending vs. Descending generations     | Parent, Parent's Sibling, or Grandparent vs. Child, Sibling's Child, or Grandchild, |
| • Matrilateral vs. Patrilineal cross kin   | Mother's Brother's Child vs. Father's Sister's Child, and                           |
| • Man-to-wife vs. Woman-to-husband affines | Man's Wife's Brother vs. Man's Sister's Husband.                                    |

Any of these axes can be used to assign grades or ranks to kin types (not to be confused with constraint rankings!), so

Faithfulness Constraints		Markedness Scales
1. DISTINGUISH SEX		
2. DISTINGUISH DISTANCE 3. DISTINGUISH GRADE		<p>A. MINIMIZE FAR KIN ≥ MINIMIZE NEAR KIN</p> <p>B. MINIMIZE JUNIOR KIN ≥ MINIMIZE SENIOR KIN</p>
4. DISTINGUISH MATRIKIN 5. DISTINGUISH PATRIKIN 6. DISTINGUISH GENERATIONS 7. DISTINGUISH AFFINES		<p>C. MINIMIZE CROSS KIN ≥ MINIMIZE PARALLEL KIN</p>

Figure 3. Seven faithfulness constraints and three markedness scales. Heavy outline shows *Ego*. Crossing a dashed line means changing the value of a distinctive feature. Following an arrow means moving toward unmarked kin.

TOP PANEL

An absolute distinction – sex – is shown as a dotted line separating male and female symbols.

MIDDLE PANEL

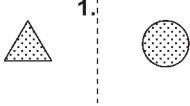
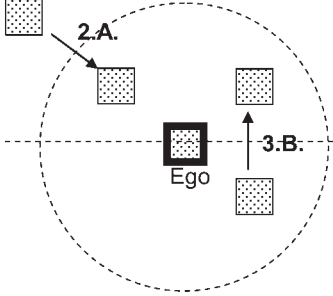
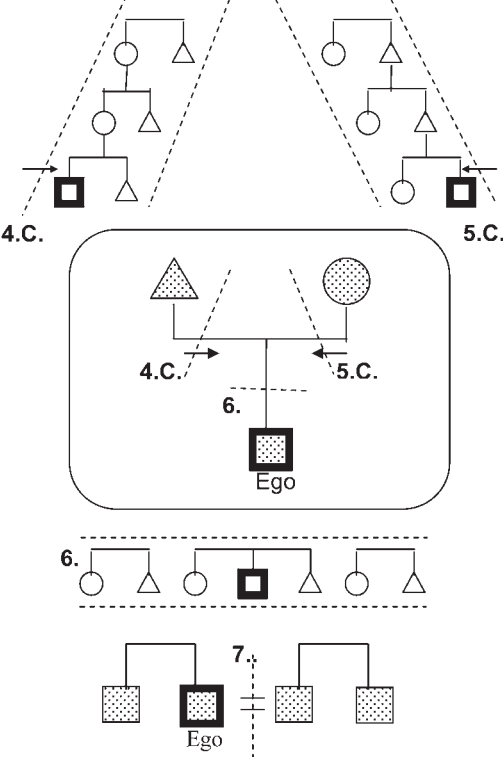
Heavy outline shows *Ego*.

The distinction between near and distant kin is shown by the dotted circle separating two squares. An arrow points toward near kin, who are less marked.

The distinction between kin ranked higher and lower than *Ego* is shown by a dotted horizontal line separating two squares. An arrow points toward high ranked kin, who are less marked.

LOWER PANEL

Three group-generating constraints are represented in two different ways.

First, the inset diagram shows the elementary conceptual operations involved in distinguishing matrikin, patrikin, and generations: in the trio of Father, Mother, and *Ego*, three dotted lines cut off Father only, Mother only, or both, from *Ego*. Arrows point toward less marked, in-group kin.

Second, three peripheral diagrams show how these cuts, applied to all father-child, mother-child, or parent-child links, generate matriline, patriline, and generations, respectively.

The distinction between consanguines and affines is represented at the bottom by a dotted line separating spouses, with marriage shown by =.

that, for example, Older Sibling ranks higher than Ego, and Younger Sibling lower. Along any axis, DISTINGUISH GRADE is violated whenever kin outranking Ego are equated with kin outranked by Ego, as long as ranks are not reversed on another axis.

Rank distinctions in terminology commonly have some basis in social hierarchy. The first two axes above are based on the hierarchy of senior and junior kin. The last two may come into play where “wife-givers” outrank “wife-takers,” or vice versa (Needham 1958; Parkin 1997).

The two preceding constraints are concerned with where a kin type is positioned relative to Ego in the web of kinship. The next four constraints are concerned instead with where a kin type is positioned relative to a group or category to which Ego belongs. Since (barring close inbreeding) the open, bilateral network of kin connections among individuals has no natural borders, groups in kinship space must be constructed by treating some kinds of kinship links as defining within-group bonds, and others as defining between-group boundaries.

4. DISTINGUISH MATRIKIN. This constraint treats a mother-child link as a bond, and a father-child link as a boundary. It allows terminological mergers among the maternally linked kin around Ego, including Sibling, Mother, Mother’s Sibling, and Mother’s Sister’s Child, but is violated by mergers between Ego’s matrikin and those across a paternal boundary, like Father and his matrikin (Father’s Sibling and Father’s Sister’s Child) or Mother’s Brother’s Child. The constraint also allows members of these out-groups to merge with one another. Applied throughout the genealogy, this principle divides kin into maternally linked groups bounded by paternal links.

With some kin types, it isn’t clear which side of the boundary they fall on. Father’s Brother’s Child – two paternal links away from Ego’s matrikin and one paternal link from Father’s matrikin – doesn’t obviously belong to either insider or outsider matrikin. The simplest assumption consistent with the cross-cultural evidence is that this ambiguous kin type can be equated with either a cross cousin, a parallel cousin, or a sibling without violating DISTINGUISH MATRIKIN. Its fate must be settled by other constraints. In the Seneca case, the classification of Father’s Brother’s Child is settled by the next constraint in the ranking, MINIMIZE COUSINS, which bars the kin type from being equated with any variety of cousin; it ends up instead being classified as some type of sibling.

5. DISTINGUISH PATRIKIN. This constraint is the sex-reversed version of DISTINGUISH MATRIKIN, treating a father-child link as a bond, and a mother-child link as a boundary. In some cases, this and the preceding constraint act interchangeably on aunt, uncle, and cousin terms, consistent with the fact that many societies with patrilineal descent groups, and presumed high rank for DISTINGUISH PATRIKIN, have more-or-less the same kin terminology as the matrilineal Seneca. Two separate constraints are necessary, however, because in other cases DISTINGUISH MATRIKIN and DISTINGUISH PATRIKIN have differing effects, producing matrilineal or patrilineal skewing. (For the role of these constraints in skewed Crow and Omaha cousin terminologies see Jones 2003b. For effects on sex-of-speaker distinctions among siblings, see Jones 2010)

6. DISTINGUISH GENERATIONS. If we go through a genealogy and snip the connections between parents and children, but keep siblings together, and their spouses

and cousins, we divide the network of kin into discrete, nonoverlapping generations. The corresponding constraint requires that kin in separate generations be distinguished from one another. Generational distinctions are found in every kin terminology. In some cases, generational and sex distinctions are almost the only ones active.<sup>2</sup>

7. DISTINGUISH AFFINES. Let a kinship formula consist of any number of consanguineal chains (see above), each separated (and maybe preceded and/or followed) by a spouse term. Then DISTINGUISH AFFINES treats any of the links between consanguines (kin by birth) as a bond and the links between affines (kin by marriage) as a boundary. It is violated when affines are equated with consanguines, or affine’s affines with either. A low rank for DISTINGUISH AFFINES results either in affines merging with consanguines (e.g., Brother-in-law = Brother) or consanguines with affines (e.g., Mother’s Brother = Wife’s Father), depending on the rank of different markedness constraints. Sometimes DISTINGUISH AFFINES works with other constraints to divide kin into marriageable and nonmarriageable classes. In these cases, the machinery for categorizing kin is enlisted to regulate not just kin terminology, but also the moral grammar of marriage rights and obligations (Lévi-Strauss 1969) – a vast topic about which I will say no more here.

By way of conclusion, it’s worth noting how these faithfulness constraints differ from the traditional distinctive features found in other work on kin terminology. Specifically, the constraints listed above omit the familiar lineal/collateral and parallel/cross distinctions. The results here suggest that these distinctions are not part of the generative machinery in their own right, but derive from the interaction of more elementary constraints. For example, the distinction in English between lineal (or direct) mother and collateral aunt (Romney & D’Andrade 1964; Wallace & Atkins 1960) results here from the interaction of DISTINGUISH DISTANCE with markedness constraints. No extra constraint is needed specifically to enforce the lineal/collateral distinction.

The parallel/cross distinction, too, may be derivative. In the present analysis, Seneca Father’s Brother’s Child is grouped with Mother’s Sister’s Child as a kind of sibling, not because the two have “parallelness” in common, but by default, because the interaction of DISTINGUISH MATRIKIN with other constraints selects an unmarked expression for the ambiguously positioned Father’s Brother’s Child. Two faithfulness constraints privileging maternal and paternal links – DISTINGUISH MATRIKIN and DISTINGUISH PATRIKIN – seem to obviate a third specifically devoted to distinguishing parallel and cross.

### 3.2. Three markedness scales

There is more to the grammar of kinship than turning distinctive features on or off. This is why, after some initial successes, early attempts to define kin categories purely in terms of necessary and sufficient conditions ran into trouble. “Whole category definitions have the problem of becoming extremely complex and hard to follow (and thus cognitively unreasonable. . .) and fly in the face of much ethnographic usage information regarding focality and the special status of focal referents” (Kronenfeld 2006, p. 210). This other side of kin terminology can be handled in OT through markedness constraints and markedness scales.



Consider this neat sequence, from English terms for affines:

Wife	<i>wife</i>	unmarked expression
Brother's Wife	<i>sister-in-law</i>	markedness <i>sensu</i> <i>stricto</i>
Uncle's Wife	<i>aunt</i>	syncretization/ contrast neutralization
Cousin's Wife	∅ (null expression)	defectivation

The list shows a series of linguistic phenomena falling under the heading of markedness. Markedness is the linguistic flip side of cognitive prototypicality: The less prototypical a concept, the more marked the corresponding expression (Greenberg 1966; 1975; 1990; Hage 2001). Markedness *sensu stricto* involves converting a prototypical expression into a less prototypical one by adding a mark (like *-in-law*, *grand-*, or *step-*). Markedness can also take other forms, as shown above.

The varieties of markedness above fall along a scale. As genealogical distance from Ego increases, less and less effort is made to tailor distinctive terms for kin types. Wife gets a term to herself. Brother's Wife wears a term borrowed from another relative (*sister*), but altered to fit her (with the added suffix *-in-law*). Uncle's Wife wears a term borrowed from another relative (Parent's Sister), and not altered to fit her. And Cousin's Wife gets no generally accepted term of her own at all.

This sequence illustrates a general rule: More terminological resources are allocated to closer kin. This can be phrased as an implicational, or if-then, rule about cross-linguistic variation: If two kin terms differ in markedness, then the more distant is generally the more marked, other things being equal. In OT, this can be handled by a markedness scale: not a constraint per se, the scale limits allowed permutations of constraint rankings. In the case of genealogical distance, the scale stipulates that markedness constraints minimizing distant terms shouldn't rank lower than constraints minimizing close kin terms. For example, MINIMIZE COUSINS should rank at least as high as MINIMIZE SIBLINGS, implying that if DISTINGUISH SEX outranks MINIMIZE COUSINS, it outranks MINIMIZE SIBLINGS too. This implies in turn that if a language makes a sex distinction among cousins, it makes a sex distinction among siblings, but not conversely. Similar reasoning applies to the relative age distinction. English, Seneca (both compounds and roots), and French all conform to these rules.

Not just genealogical distance, but other distinctive features and faithfulness constraints in Figure 3 have preferred, unmarked directions associated with them. There is good cross-cultural evidence for the following three markedness scales (Hage 2001):

A. MINIMIZE FAR KIN  $\geq$  MINIMIZE NEAR KIN (associated with DISTINGUISH DISTANCE and DISTINGUISH AFFINITY). Cousins are marked relative to siblings, grandparents relative to parents, children's spouses relative to children, siblings' spouses' siblings relative to siblings' spouses. More generally, given a compound kin type XY at a greater consanguineal or affinal distance than either of its component types, X and Y, we expect markedness scales of the form MINIMIZE XY  $\geq$  MINIMIZE X and MINIMIZE XY  $\geq$  MINIMIZE Y. Note that there is no implication about the markedness of XY relative to some other kin type

Z. For example, Parent's Parent is marked relative to Parent, but not necessarily relative to Child.

B. MINIMIZE JUNIOR KIN  $\geq$  MINIMIZE SENIOR KIN (associated with DISTINGUISH GRADE). Younger siblings are marked relative to older siblings. Nieces and nephews are marked relative to aunts and uncles. Grandchildren are marked relative to grandparents. More generally, other things being equal, if X is senior to Ego and Y is junior, we expect a markedness scale of the form MINIMIZE Y  $\geq$  MINIMIZE X.

Directional distinctions other than senior/junior distinctions don't have consistent associated markedness scales. Take brothers-in-law. Cultures vary in whether they assign a higher rank – and more terminological distinction – to the wife-giver who relinquishes a sister, the wife-taker who marries her, or neither. There is no universal scale of Wife's Brother relative to Sister's Husband.

C. MINIMIZE CROSS KIN  $\geq$  MINIMIZE PARALLEL KIN This scale is a summary of two scales. One of these, associated with DISTINGUISH MATRIKIN, makes Father's Sister and her children marked relative to Mother's Sister and her children. The other, associated with DISTINGUISH PATRIKIN makes Mother's Brother and his children marked relative to Father's Brother and his children. More generally, cross kin, linked through opposite-sex relatives, are marked relative to parallel kin, linked through same-sex relatives.<sup>3</sup>

Languages mostly follow the markedness scales above, but otherwise they freely invent markedness constraints of the form MINIMIZE KIN TYPE as they see fit. For example, both English and Seneca treat aunts and uncles symmetrically, implying they have a single constraint, MINIMIZE PARENTS' SIBLINGS, regulating these terms. But other languages observe fewer (or more) distinctions among aunt terms than uncle terms, implying that they split MINIMIZE PARENTS' SIBLINGS into two constraints, MINIMIZE AUNTS and MINIMIZE UNCLES, with the former ranking higher (or lower) than the latter.

#### 4. Optimality and derivations

Before stepping back to assess these findings, consider one more topic: the extension of kin terms to indefinitely distant kin, like second and further cousins. This has been an important area of research in kin terminology, and it may have a wider significance as well. Kin term extension involves recursion, and the revision of OT needed to accommodate it may have implications for grammatical recursion more generally.

##### 4.1. Further cousins

As we have seen, Seneca classifies first cousins as cross cousins or siblings, depending on the sex of connecting parents. But what about a second cousin, an Older Mother's Mother's Brother's Son's Son, say? One might imagine that the machinery of kin classification would choke on such a super-sized input, as English does on Cousin's Wife. But in Seneca the relative in question as *ahgareseh* – 'cross cousin.' Other second-cousin types are likewise classified as cross cousins or siblings, with siblings further distinguished by sex and relative age (Lounsbury 1964a).

In some cultures, kin term extensions are socially important – dividing distant kin into marriageable and unmarried categories, for example. This doesn't apply among the

Seneca, but the extension of the parallel/cross distinction to more distant cousins is highly systematic all the same. Anthropologists have developed several approaches to account for kin term extensions in Seneca and other languages, including reduction rules (Buchler & Selby 1968; Gould 2000; Kronenfeld 2009; Lounsbury 1964b; Scheffler 1968) and kinship algebra (Read 1984; 2001a). There are important differences between these approaches (more on this in the next section), but here we are interested in what they have in common. Both offer what linguists call a derivational account of kin terms, in which arriving at appropriate terms for distant kin takes many small steps rather than one giant leap.

This is very different in spirit from standard Optimality Theory. Given an input, standard OT says, “Find the output, whatever it may be, that best satisfies constraints 1, 2, 3, and so on.” A derivational theory says, “Apply rule 1 to transform the input. Apply rule 2 (or maybe rule 1 again) to transform the result. And so on.” These approaches to kin terminology can be reconciled, but this requires a revised version of OT. The revised version says, “Find the output, whatever it may be, *in the immediate neighborhood of the input*, that best satisfies constraints 1, 2, 3, and so on. Repeat, using this output as the new input. Keep repeating until a steady state is achieved.” The journey from input to output, however long, will proceed in small steps.

Below I consider how one widely used derivational approach, the method of reduction rules, may be incorporated into OT. First, the sequence below shows how reduction rules work on a second cousin input in Seneca (following Lounsbury 1964a). On the left are kin formulas, on the right, rules that transform one formula into the next. It is convenient (but maybe not absolutely necessary) to assume that, with each move, at most one pair of adjoining elementary kin types changes.

Older Mother’s <u>Mother’s</u> <u>Brother’s</u> Son’s Son	Reduce “___ Mother’s Brother’s ___” to “___ Father’s ___”
Older Mother’s <u>Father’s</u> <u>Son’s</u> Son	Reduce “Father’s Son” to “Brother”
Older Mother’s Brother’s Son	Don’t reduce “Mother’s Brother’s ___” to “Father’s ___”. Eliminate sex and relative age.

‘cross cousin’ (*ahgareseh*)

The last part of the sequence, from Older Mother’s Brother’s Son to ‘cross cousin,’ restates a familiar result for first cousins. In Seneca, Mother’s Brother’s Child cannot be subsumed under a sibling term: this would violate DISTINGUISH MATRIKIN, the constraint keeping adjacent matrilineal lines apart. Further constraints dictate that cross cousins are not distinguished by sex or relative age.

But something else is going on at the beginning. Here, the formula Mother’s Brother is embedded on both sides in a larger formula. And this doubly embedded Mother’s Brother is treated differently. According to the rule on the right, a Relative’s Mother’s Brother’s Relative (written “\_\_\_ Mother’s Brother’s \_\_\_”) should be replaced with that Relative’s Father’s Relative (written “\_\_\_ Father’s \_\_\_”). This is unexpected, because Mother’s Brother and Father belong

to adjacent matrikin, and in the case of first cousins, aunts, and uncles, Seneca is meticulous about keeping adjacent matrikin separate. But apparently when Mother’s Brother is buried deeply enough inside a larger expression, the contrast between adjacent matrikin is neutralized. This is a markedness effect: A distinction observed with one kin type is ignored when that kin type is part of a larger formula.

OT is good at managing trade-offs between distinctive features and markedness. One might imagine that a constraint ranking like the following would handle Seneca cousin extensions:

- MINIMIZE 2ND, ETC., COUSINS
- DISTINGUISH MATRIKIN
- MINIMIZE COUSINS
- DISTINGUISH SEX
- DISTINGUISH GRADE
- MINIMIZE SIBLINGS

This is a portion of the ranking previously given for Seneca, with the addition at the top of one constraint, MINIMIZE 2ND, ETC., COUSINS, which decrees that second and further cousin terms must be eliminated even at the expense of merging adjacent matrilineal lines.

But it takes more than just adding markedness constraints to manage kin term extensions. The ranking above gives the wrong results if we follow standard practice and allow moves of any size. In the present case, one potential move goes directly from the second cousin input to a sibling type like ‘older brother.’ This move obeys the MINIMIZE COUSINS constraint, and the next two as well, so ‘older brother’ should be the optimal output. More generally, all second and further cousins should be classified as siblings. Standard OT effectively short-circuits the piece-by-piece replacement given by the reduction rules above, giving results contrary to those in Seneca and many other languages.

We could get around this by fiat, by declaring, by fiat, that DISTINGUISH MATRIKIN extends cross and parallel distinctions out indefinitely in the appropriate fashion (Woolford 1984). But there are several problems with this. First, the proposed redefinition is ad hoc, with no motivation or grounding in markedness theory or otherwise. Furthermore, across cultures there are several different ways of extending the parallel/cross distinction, so we would be forced to introduce additional versions of DISTINGUISH MATRIKIN to accommodate this variation. Finally, it is psychologically and ethnographically implausible that a formula like Older Mother’s Mother’s Brother’s Son’s Son is processed in one gulp.

A better solution is to incorporate the iterated processes featured in derivational theories into a revised version of OT. This means accepting a restriction on the size of moves, but allowing the output to be fed back into the input repeatedly. It means that on any one move, a constraint like REDUCE 2ND, ETC., COUSINS will accept “partial payment” – a small move away from second or further cousin terms, such as replacing an embedded Mother’s Brother with an embedded Father. Given this revision, we can generate the full array of Seneca cousin terms out to indefinite distances. (In practice, the Seneca usually gave up after third cousins.) Thus, by switching from one-shot, global optimization to multistep, local optimization, OT can capture the advantages of derivational approaches, with the added advantage that derivational rules aren’t just stipulated, but derive systematically from constraint rankings.<sup>4</sup>

#### 4.2. Local optimality and minimal moves

The case for a more derivational, local version of Optimality Theory would be stronger if it applied to more than just kin terminology. Encouragingly, both phonology and syntax have been moving in this direction lately.

In phonology, standard OT, in spite of its successes, has trouble accounting for some phenomena. For example, in American English (McCarthy 2007, pp. 1–2), it apparently takes two steps to get to the standard pronunciation of *planted*, the past tense of *plant*. On the first step, /plænt/ and /-d/ are combined, but an extra [ə] is added – thus [plænt.əd]. This avoids the articulatory challenge of pronouncing two dental stops in immediate succession. But unless speakers are being hypercorrect, there is normally a further change in pronunciation. The [t] is dropped, yielding [plæn.əd]. The [ə], introduced to solve the problem of a now-absent [t], is opaque – not motivated on the surface. For a derivational account this is not a problem: [ə] is added at one step, [t] is dropped at the next. But it is a problem for standard OT. What markedness or faithfulness constraints could possibly account for an added [ə] that makes the output both more marked and less faithful to the input?

Probably the most promising approach to phonological opacity within OT involves moving from global to local optimization. The argument is set forth at length in McCarthy (2007). In McCarthy's revised version of OT, candidate chain OT, only minimal moves in the immediate neighborhood of the input are allowed. The optimal output is selected in this neighborhood, the output is returned as input, and the process is repeated until no more locally optimal changes can be made. Optimization takes place according to strictly ranked constraints, as in standard OT.

All of this is very similar to the integration of OT and reduction rules proposed above for kin terms. For example, in candidate chain OT, some constraints may be written so that they are activated only after other constraints have been brought in to play. Similarly, with Seneca cousin terms, the parallel/cross distinction is effectual only after a formula has been boiled down to a first cousin expression.

In syntax as well, linguists have begun to explore localized versions of OT. These involve building up phrase structure trees one small step at a time, with each step governed by OT (Heck & Müller 2006; Müller 2003). This research has the potential, if preliminary results hold up, of reconciling optimality and derivational approaches to syntax, which have grown far apart in recent decades.

In short, there is reason to suppose that kin terminology, phonology, and maybe syntax have a common architecture reflecting the principles of OT. But in each case, there are problems with the standard, global version of OT. It is liable to “short circuits,” getting wrong answers by taking big jumps from marked input to unmarked output. It also gets computationally implausible as combinatorial possibilities multiply. The alternative, local optimization, moving from input to final output in small steps, may be a general design feature of grammar.

### 5. From conceptual structure to grammar

The study of kin terminology delineates what look like two pieces of evolved psychology. These work together in regulating individual learning and cultural evolution of kin terms, but are functionally distinct. They may be phylogenetically

distinct as well, with the conceptual structure of kinship ancient, partly shared with other primates, and evolutionarily derived from more primitive domains of conceptual structure (Seyfarth & Cheney 2008), and with grammar recent and uniquely human. I review each in turn.

#### 5.1. Conceptual structure 1: Constraints and the space of kinship

Kinship is normally conceptualized in spatial terms.

Kinship maps always utilize a spatial imagery. I have seen no exception to this. People around the world commonly speak of “sides,” “lines,” “distant” or “close” relatives, and reckon relationships “upward” or “downward.” Because of this, the best way to capture the conceptual structure of systems of kinship definitions without using one's own cultural conceptions as an obscuring filter is usually to ask for diagrams, not lists. (Leaf 2006, p. 308)

Here I take this observation a step further by comparing the conceptual structure of physical space, as revealed by previous analyses of closed-class linguistic forms, with the conceptual structure of kinship space, as revealed by constraints on kin terms.

Consider the following scene: There is a focal object or figure. This object stands at some distance and in some direction and orientation in relation to a background object, or ground. The ground is at least as spatially extensive as the figure. Information about figure and ground is limited, but includes such distinctions as whether they are simplex (a single object) or multiplex (a group of objects treated as one thing). Information about the relationship between figure and ground is also limited. It is, roughly speaking, topological rather than metric, and digital rather than analog. It may include relationships like near and far, above and below, or inside and beside, but not actual measurements of distance or position.

This description could be a representation of material objects in physical space. It doesn't fit the rich representation of objects and space in conscious perception, but corresponds to a more pared-down conceptual representation in which most information about shape, texture, color and kind of objects, and about spatial metrics, has been stripped away. This mode of representation is manifest in English spatial prepositions, and across a wide range of languages in a variety of closed-class forms concerned with space (Levinson & Wilkins 2006). But (I will argue) this description also fits the conceptual structure of kinship. The parallels are evident in Figure 3, where constraints on kin terms are divided horizontally into those concerned with (1) absolute qualities of the figure (the referent of the kin term), (2) the relationship – distance and direction – between figure and ground, and (3) the nature of the ground (the anchoring individual or group to whom the figure is related).

Taking these in turn: In the grammar of physical space, the bare, existential thing-hood of the figure is typically indicated by assigning it a noun. In kinship space, likewise, even though kinship is a relationship, kin types are mostly treated as abstract “things” by assigning nouns to kin terms. (Dahl & Koptjevskaja-Tamm 2001; for scattered exceptions where kinship is indicated by verbs, see Evans 1999.) And in kinship space, as in physical space, only a very limited subset of potentially relevant information about the figure actually registers grammatically. Usually

the only nonrelational information about kin types that makes it into kin terms is their sex.

The second class of constraints, those concerned with kinship distance and rank, also shows obvious parallels with spatial grammar. For example, in both kinship space and physical space, the grammatical system mainly trades in quasitopological or qualitative, rather than metric, information. Thus age distinctions in sibling terms normally encode whether the sibling type in question is older or younger than Ego (as in Seneca), or, less often, the sibling's birth order: first, second, third, and so on. They don't normally encode age differences in years, or absolute ages. Nor do affinal distinctions register how long a couple has been married.

Finally, to understand what the third class of constraints on kin terms is up to, we turn once again to parallels with the conceptual structure of physical space. In closed-class forms relating to physical space, a commonly registered distinction is that between simplex objects (a bird, an island, a star) and bounded collections of objects (a flock, an archipelago, a constellation) (Jackendoff 1991; Talmy 2000b). The same distinction is at work in kin terminologies: Kin terms can register the relationships of individuals to other individuals (near or far, higher or lower), but they may also register the relationships of individuals to more extensive background groups or categories (inside or across the group boundary). In the analysis here, three constraints – those distinguishing *matrikin*, *patrikin*, and generations – are sensitive not to the relationship between a kin type and an individual Ego, but to the relationship between a kin type and a bounded group to which Ego belongs.

Thus the findings here extend one of the major discoveries in the study of conceptual structure: kin terminology, like other abstract semantic domains, such as time, change of state, and possession, borrows much of its organization from the conceptual structure of space. What is new here is not the idea that we can talk about kinship space and kinship distance, but the tracing of close parallels in conceptual structure in both cases. Optimality Theory is an important part of the analysis, because the distinctive features uncovered using OT manifest the parallels with spatial cognition especially clearly.

## 5.2. Conceptual structure 2: Genealogy and the nature of the input

The conceptual structure of kinship has something in common with other domains of conceptual structure, but it has its own logic as well, deriving neither from conceptual structure in general, nor from Optimality Theory. For example, consanguineal distance is measured in a special way, starting from neighboring elements and counting links up and then down. This is more like pedigree distance, as measured by geneticists or genealogists, than physical distance as measured by surveyors. This subsection considers what's special about the structure of kin terminology, with a focus on what the present theory has to say about one of the most contentious issues in anthropology, the relationship between kinship and genealogy.

Anthropologists distinguish between genealogical definitions of kin terms – how genealogical positions map onto terms – and categorical definitions – how terms are related to one another. Up to this point, our application of OT to kin terminology has been straightforwardly genealogical.

The input to the machinery of kin classification was stipulated to be a kin type – a genealogical formula – like Mother's Older Sister. The assumption, never explicitly defended, was that however much kin terms vary, they are built up from elementary types shared across cultures. An implication is that kin terms are intertranslatable: terms from one language can be defined using terms from another language (sometimes with the addition of extra distinctions, like Older or Younger). For example, in explaining Seneca aunt terms to an English speaker, one could say that in Seneca, mother's sister but not father's sister is equated with mother. Conversely, one could explain English aunt terms to a Seneca speaker by saying that English equates both the *ahje* ('older sister') and the *kaga* ('younger sister') of *noyeh* ('mother') with *ahgahuc* ('father's sister') rather than with *noyeh*.

But there are problems with a strictly genealogical approach to kin terms. It is commonly observed that people can, and often do, apply kin terms without knowing all the genealogical connections involved (Keesing 1975; Levinson 2006a; Read 2001b). To see how this is possible, note that a Seneca speaker can figure out that the *ahje* of a *noyeh* is a *noyeh* without actually knowing whether the kin involved are genealogical or classificatory older sister and mother. Another common observation is that in some societies even an individual known to be unrelated by birth or marriage – a resident anthropologist, perhaps – may be assigned a place as someone's daughter or brother, and then enfolded systematically into the whole network of kin.

Nongenealogical kinship is not fatal to the OT approach to kin terms; it can be accommodated by expanding the range of allowed inputs. Specifically, OT can handle nongenealogical inputs as long as these are amenable to evaluation by the kin term constraints, which are concerned with questions like "Is the input female or male?" and "Does the input belong to the same generation as Mother?"

Suppose, given a Seneca constraint ranking, we try the input 'mother's' 'older sister,' where the terms in single quotes are understood, not as genealogical formulas – what an English speaker might call "real" mother or older sister – but as glosses on Seneca categories. This input is well-formed, because even without knowing the exact genealogy, we can say that equating the input with 'sister' violates DISTINGUISH GENERATIONS, equating it with 'father's sister' violates DISTINGUISH MATRIKIN, and so on. Applying constraints as before we get the correct optimal output: 'mother's older sister' merges with 'mother.'<sup>5</sup> Thus pluralism about allowed inputs in OT makes room for both genealogy and category. Allowing nongenealogical input is consistent with evidence that people can figure out appropriate kin terms using either explicit genealogical reckoning, or terminological shortcuts, or both, depending on the context.

So what does the formal analysis of the language of kinship tell us about the relationship between kinship and genealogy? Many anthropologists argue that, because kin terms are often applied where genealogies are unknown or nonexistent, a genealogical definition of kinship is unworkable (Read 2001a; 2001b). Some go even further and argue that definitions of kin terms, and theories about how people become kin and what kin share, are so widely variable as to call into question whether kinship even exists as a proper subject for cross-cultural study (Schneider 1984). According to some skeptics, anthropologists should abandon the study of kinship for the study of folk ideas of "relatedness," an open-ended polythetic domain which might not overlap

much with Western notions of parenthood and consanguinity (Carsten 1997).

But simply dismissing the connection between kinship and genealogy in this way means ignoring one of anthropology's great empirical findings: Pretty much every society has a system of kin terms. These are recognizable as kin terms by the way genealogy maps onto them. "It is clear that our informants quite generally 'know' which genealogical relatives go in which kin categories" (Lehman 1993, p. 99). Figure 2 shows a portion of this mapping for English and Seneca, and similar figures can be found in hundreds of articles and books on kinship. Somehow, the distinctive features that kin terminologies care about are systematically related to genealogical distinctions. According to the present theory, this follows from the restriction that inputs, whether genealogical or categorical, must be well-formed – amenable to evaluation by the kin term constraints. The result is a systematic correspondence between genealogical and kin term distinctions, mediated by the workings of OT, so that, for example, a faithfulness constraint concerned with consanguineal distance helps to generate a kin terminology with a lineal/collateral distinction (sect. 3.1).

There is a paradox here. Kin terms (according to many anthropologists) don't have genealogical definitions, but (according to considerable evidence) are genealogically structured. The present theory offers one possible resolution to this paradox: recognizing two levels of mental representation for kinship, corresponding to the content and conceptual structure of kin terms. (For content/structure distinctions in other semantic domains, see Grimshaw 2005; Pinker 1989; 2007). While the content of individual kin terms may vary widely and idiosyncratically across cultures and be deeply entangled with local theories of procreation and shared substances, the conceptual structure of kinship manifest in the grammar of kin terms is more universal – and shows every sign of being adapted for tracking genealogical connections.

### 5.3. The grammar faculty

Talking about kin – more specifically, using terms for different kin types – is a different problem than thinking about them. Thinking about kin involves fitting one's thoughts to local facts about kinship. Mastering a kin terminology involves, additionally, fitting one's words to local communicational conventions. Talking about kin is one example of a coordination game, in which the goal is to choose, not the one right answer, but the same answer as everyone else. Playing coordination games is something of a human specialty – maybe even *the* key human behavioral specialization (Levinson 2006b; Tomasello et al. 2005). One approach to the grammar of kinship, then, and to grammar in general, is to consider its place among games of coordination and communication (Blutner et al. 2006).

One way to play a coordination game involves a kind of mind reading, in which signaler and recipient cooperate by carrying out on-the-spot simulations of one another's inferential and performative dispositions (Sperber & Wilson 1995/1986). If you and I both know that we are trying to coordinate our behavior, we may be able to arrive at a shared understanding through one-off signals we mutually recognize as intentional signs obeying maxims of cooperative communication. This kind of mind reading allows human beings to cooperate even

without a shared language, as in situations of first contact between cultures.

Some communicative acts go beyond one-off exchanges by reproducing conventional signs. The learning of conventional signs is governed by further cooperative maxims (Bloom 2000). The learner not only connects a sign with a meaning, but also assumes that other members of the community will make the same connection when they interpret or produce the sign. She assumes that novel signs have novel meanings, rather than being synonyms of familiar signs (Diesendruck & Markson 2001).

Finally, conventionalization may go one step further. The precedents set by communicative acts may be generalized to produce systematic rules for encoding information. Human communication thus runs along a spectrum, from less to more conventionalized, from pragmatic to grammatical.

The contrast between pragmatic-inferential and grammatical-encoded communication is a commonplace in linguistics. But for many authors, grammar is just a synonym for syntax or morphosyntax (Sperber & Wilson 1995/1986). This article takes a more inclusive approach. Phonology is grammatical, and, according to the argument above, so is kin terminology. Grammatical principles may govern other semantic fields – including body parts, colors (Jones 2010; Kay & Maffi 1999), and spatial relationships (Levinson & Wilkins 2006) – as well as the interface between semantics and morphosyntax – including pronouns and subject choice (Aissen 1999) and verb argument structure (Legendre et al. 2006) – and morphology and syntax more generally (Legendre et al. 2001).

Taken as a whole, this work implies that there is more to grammar than semantics, phonology, morphology or syntax in isolation. The rest of this article advances a strong hypothesis about this extra something, arguing that part of the uniquely human suite of adaptations for playing coordination games is a grammar faculty, adapted to facilitate the construction of locally shared codes of communication and interaction. This faculty interacts with, but is distinct from, domain-specific adaptations in conceptual structure, phonology, and syntax. In each domain, the grammar faculty solves several problems: (1) using ranked constraints to generate grammatical outputs, (2) matching the learner's constraint rankings with community rankings, and, more tentatively, (3) discovering constraints. I consider these in turn.

1. How ranked constraints generate grammatical output is well-trodden ground in Optimality Theory. Not so well understood is why OT works the way it does – why, particularly, it resorts to ranking rather than quantitative maximization to handle constraint trade-offs. The grammar faculty hypothesis implies one answer (suggested independently by other researchers: Smolensky & Legendre 2006), that constraint ranking is adapted to the demands of communication and other coordination games.

By way of illustration, consider the functional demands of two tasks, allocating assistance to kin, and communicating about them. At its simplest, the first task is a matter of household economics, of distributing scarce resources among oneself and one's relatives. According to a well-known result in evolutionary theory, this can be treated as a maximization problem (subject to some restrictions: Frank 1998). The evolutionarily optimal solution maximizes a quantity called inclusive fitness. The second problem is different. Given the problem of what to call different kin, there is an enormous array of possibilities for separating, marking,

merging, and omitting terms. As members of a language community make trade-offs between supplying information and avoiding effort, the crucial consideration is that they make the same trade-offs. OT solves this coordination problem readily, asking of speakers and hearers only that they share a constraint ranking. With a shared constraint ranking, the Seneca, for example, can settle on Mother's Sister being called 'mother,' with further implications for other relatives (every Mother's Sister's Child is some type of sibling), without having to precisely equate quantitative feature weights or encyclopedic knowledge. Just as particulate inheritance in genetics improves the fidelity of replication between generations, the strict ranking of discrete constraints makes it easier for language communities to reproduce standardized codes. Although more theoretical work needs to be done, it is plausible that OT grammars flourish where they do because of their advantages for communication.

2. Since constraint rankings vary across cultures, they have to be learned. This process is fairly well understood, at least in outline. Given a shared constraint set, language learners can solve the induction problem of generalizing from limited input to rules of language by using a procedure called constraint demotion to match their constraint rankings with those in the local speech community (Tesar & Smolensky 2000). Briefly, this works as follows: The learner begins with some constraint ranking – generally one in which markedness constraints outrank faithfulness constraints. When she hears others speaking in a way inconsistent with her current ranking, she identifies the constraints responsible for the inconsistency, and moves them far enough down in her constraint ranking to remove the inconsistency – but no farther – repeating as often as necessary. This procedure converges fairly quickly on the correct constraint ranking: With  $n$  constraints, the number of possible constraint rankings, ignoring scales, is  $n!$ , but the number of informative examples needed for the constraint demotion algorithm to work is a manageable  $n \cdot (n-1)$ .

Applied to kin terms, constraint demotion implies that when a child learns that Mother's Sister is equated with Mother she is not just learning a single word. She is also learning a precedent that will affect other kin terms she learns. More specifically, she is learning that MINIMIZE PARENTS' SIBLINGS outranks DISTINGUISH DISTANCE, which blocks the inclination to learn distinct terms for certain more distant kin, like Mother's Sister's Child (given the scale MINIMIZE FAR KIN  $\geq$  MINIMIZE NEAR KIN). But not conversely: If she hears a Cousin called Sibling, this will not block her learning that his mother is called something other than Mother (D'Andrade 1971). The grammar faculty hypothesis thus has still-untested implications for how kin terms are learned.

3. The grammar faculty faces one further problem. According to OT, constraints or constraint schemas are universal. But where do universals come from? This area of OT is not well-understood, but we can at least compare two possible kinds of answer.

Constraints could be innate. In each of the domains in which grammar operates, language learners might face a fixed menu of constraints ready to be ranked. For each domain there would be a separate evolutionary story about where constraints come from. Applied to kin terms, this would imply that not just the conceptual structure of kinship, but actual constraints on kin terms – or maybe more abstract constraint schemas for space-like conceptual structure – are built into humans by natural selection.

This simple solution is not very plausible for kin terms, or in general. In phonology, where the topic has received most attention, a recent review concludes that "the innateness hypothesis faces two obstacles: it fails to provide credible accounts of either the epigenesis or phylogenesis of [constraints]" (Bermúdez-Otero & Börjars 2006). The alternative is that constraints are neither innate nor culturally acquired, but discovered. Theories of constraint discovery are not as well-developed as other areas of OT, but in general terms, constraint discovery involves a learner's grammar machinery monitoring her psychological operations – perceptual, conceptual, and motor – on the lookout for salient prototypical and distinctive features likely to be mutually relevant to speakers and hearers. (Bermúdez-Otero & Börjars, 2006, review several proposals for phonology.) Constraint discovery is a coordination game, with each player trying to zero in on a set of constraints likely to be chosen by everyone else. On this view, grammar would have a well-defined function, but its scope would be open-ended. Grammars could grow opportunistically, colonizing any "grammar-friendly" cognitive or perceptual domain in which universals of psychology provide common ground for developing shared codes.

Thus, the study of kin terms does not lead to the discovery of one special-purpose module: there is no Kin Term Acquisition Device. Instead, there is a conceptual structure of kinship, partly homologous with conceptual structure in other domains, partly of specialized design. And there is a grammar of kinship, bridging the gap between thoughts and words with communicational principles of more general application. The study of kin terms, in other words, leads beyond kin terms, to "fundamental structures of the human mind" (Lévi-Strauss 1969, pp. 75, 84).

#### ACKNOWLEDGMENTS

The author would like to thank Paul Bloom, Matthew Denio, Per Hage, Steven Pinker, and several anonymous reviewers for comments and advice on various stages of this enterprise, and the Department of Anthropology and the College of Social and Behavioral Sciences of the University of Utah for support.

#### NOTES

1. Following the example of Lounsbury (1964a), the constraint ranking for Seneca glosses over the fact that Seneca "words" for siblings are compounds, with no sex distinction in the root (Kay 1975). This can be accommodated in an OT framework by using several constraints distinguishing sex, with different ranks. One set of constraints, part of Seneca rules for compounding, automatically imposes sex distinctions on a non-self-reciprocal like Older Sibling, but not on a self-reciprocal like Cousin (roughly *she-older-sibling-me* or *he-older-sibling-me* versus *we-cousin-each-other*). Another constraint, closer to kinship semantics *sensu stricto*, handles sex distinctions among roots.

2. There is not just one, but a family of generational constraints active across cultures. The extra constraints can be assembled out of existing constraints using a standard technique from OT called *constraint conjunction* (McCarthy 2001, p. 18). A conjunctive constraint combines two constraints; it is violated only if *both* of its constituent constraints are violated. A constraint active in many kin terminologies combines DISTINGUISH GENERATIONS and DISTINGUISH DISTANCE. This constraint, DISTINGUISH GENERATIONS & DISTANCE, bars any terminological merger of kin types in different generations at different distances from Ego, but allows child (generation -1) to merge with parent (+1), or grandchild (-2) with grandparent (+2). Another conjunctive constraint, DISTINGUISH GENERATIONS & GRADE, bars any

terminological merger of kin types between ascending and descending generations, but allows grandparent to merge with parent, or grandchild with child. In other words, if two kin types  $m$  and  $n$  generations away from Ego are merged, DISTINGUISH GENERATIONS & DISTANCE is happy as long as  $m$  and  $n$  have the same absolute value, and DISTINGUISH GENERATIONS & GRADE is happy as long as  $m$  and  $n$  have the same sign. Both grandchild/grandparent and grandparent/parent mergers are common across cultures (Murdock 1970). In English they are found in the prefixes and roots, respectively, of grandkin terms.

3. The three scales cover most markedness relations in kin terminology, but not all. Greenberg (1966) suggested provisionally that female kin are universally marked relative to male. But evidence for this is conflicting; the relationship seems to be reversed in some languages, including Seneca (Lounsbury 1964a). Another markedness gradient entails that elaborated, specific kin types are marked relative to unelaborated and generic: Parent's Younger Brother is marked relative to Parent's Brother, which is marked relative to Parent's Sibling. Instead of adding constraints and scales to handle this, we can simply stipulate that more specific types incur more violations of MINIMIZE PARENTS' SIBLINGS than less specific types. Finally, gradations of markedness (as in English affinal terminology, above) involve the interaction between markedness scales for kin terminology and other markedness scales covering varieties of markedness (Jones 2010).

4. Some complications should be noted. First, we can better capture how markedness constraints generate reduction rules in local OT by rewriting MINIMIZE SECOND, ETC., COUSINS as MINIMIZE \_\_\_ PARENTS' SIBLINGS' \_\_\_, which calls for the doubly embedded material to be replaced, with the replacement subject to the remaining ranked constraints. Second, note that in the reduction sequence, Father's Son is replaced by Brother. In the OT approach, no explicit rule is needed to produce this result, as long as there is no faithfulness constraint explicitly preventing it, which fits the cross-cultural data. Third, we give the optimal replacement for a doubly embedded Mother's Brother as Father. But this follows only if possible replacements are limited to *consanguineal* kin in the same *generation*, which in turn follows only if two constraints not shown here, DISTINGUISH AFFINES and DISTINGUISH GENERATIONS, have a high rank. If we relax this assumption, and give a low rank to either of these constraints, we get various common non-Iroquois terminologies, such as Dravidian or Crow (Lounsbury 1964a; 1964b).

5. Not every possible combination of kin terms is a well-formed input. A Seneca speaker couldn't give the correct term for a child of mother's *ahgareseh* ('cross cousin'), for example, without knowing the cross cousin's sex, which *ahgareseh* omits. The corresponding input is ill-formed unless information is added to give DISTINGUISH MATRIKIN enough to work on.

such a machinery is plausible. Because individuals never need to learn the entire spectrum of kin terminology, they could rely on data-driven learning. The complexity of Jones's machinery for kin classification casts doubt on the existence of innate structures that cover the complete linguistic domain.

Jones claims that his extended framework of Optimality Theory (OT) overcomes the limitations of previous accounts of kin terminology. His application of the study of conceptual structure to kin terminology and his finding that the latter "borrows much of its organization from the conceptual structure of space . . . [and] the tracing of close parallels in conceptual structure in both cases" (sect. 5.1) promises to integrate kin terminology within human cognition.

In spite of these promising aspects of the paper, several problems remain. First, Jones has given us no new reason to believe that kinship terminology *has to have* a universal grammar (UG). Taking kinship UG for granted, he never addresses standard criticisms of UG in the linguistic domain from developmental (e.g., Behme & Deacon 2008; Edelman & Waterfall 2007; Elman et al. 1996; Monaghan & Christiansen 2008; Redington et al. 1998; Sagae et al. 2004; Solan et al. 2005; Tomasello 2003; 2006) or evolutionary (e.g., Arbib et al. 2008; Botha 1999; Christiansen & Chater 2008; Deacon 2007; MacWhinney 2005; Studdert-Kennedy 1998; Tomasello 2008) perspectives. While it seems possible that the universal rules Jones discusses exist, he has not shown that all humans rely on the same innate "template" to assign kinship terms. Given the complexity of constraints and rankings that become already evident in the two languages Jones discusses in detail, it appears questionable that the suggested version of OT could apply to all existing human cultures without spiraling into a computationally unmanageable system. Nor is it evident how such an intricate "machinery of kin classification" (sect. 5.2) might have evolved through natural selection. The constraints and trade-offs suggested just for the small segment of existing kinship terms Jones discusses give a flavour of the complexity required by a system that covers universally all human societies. And Jones does not even consider complicating factors such as within language variation of kinship assignments, polygamous or same sex marriages, divorce, and remarriage. It would appear that kinship terminology needs to remain flexible to account for the fluidity of the input, and Jones does not make it clear how an innate system could offer such flexibility.

Jones observes that kin terminology is highly constrained: "Languages around the world have independently hit on similar patterns, while largely steering clear of other imaginable possibilities. Kin terminologies are not perfectly regular, but overwhelmingly so" (sect. 2.3). He takes this as support for his theory. Yet, it is also possible that kin terminologies are similar because what they describe is similar: There are limits on how human beings can be related to one another, how property can be passed on to the next generation, how sexual relationships (e.g., marriage) can be executed, and more. When learning kin terminology, individuals face a very limited specific subset of the potentially possible kin arrangements. Thus, it is imaginable that they learn the relevant kin terms from the input they receive without having to rely on an innate system that has to accommodate all possible arrangements. Furthermore, some of Jones' examples appear to be post hoc. Seemingly, we have to know how English and Seneca assign kinship terms before we can design the system that accounts for these assignments. Potential counterexamples are then accounted for by invoking additional "rules." Take the Seneca derivation of "Older Mother's Mother's Brother's Son," which results in 'cross cousin.' Jones admits that this violates constraints invoked earlier because "in the case of first cousins, aunts, and uncles, Seneca is meticulous about keeping adjacent matrikin separate" (sect. 4.1). Yet, given that 'cross cousin' is the term used by the Seneca, Jones holds that "apparently when Mother's Brother is buried deeply enough inside a larger expression, the contrast between adjacent matrikin is neutralized. This is a markedness effect." (sect. 4.1). It is not clear how Jones' system could have predicted when to invoke the markedness effect had we not already known

## Open Peer Commentary

### Does kinship terminology provide evidence for or against universal grammar?

doi:10.1017/S0140525X10001913

Christina Behme

Department of Philosophy, Dalhousie University, Halifax, NS B3H 4P9, Canada.

Christina.Behme@dal.ca

**Abstract:** Jones introduces an intricate machinery of kin classification that overcomes limitations of previous accounts. I question whether

what the output is. This holds true even if we accept that Jones uses a revised form of OT that incorporates iterated processes which restrict the size of moves and allow the output to be fed back into the input repeatedly. It may be true that this revision “can generate the full array of Seneca cousin terms out to indefinite distances” (sect. 4.1). But, given that “cousin terms to indefinite distance” have no practical application in actual language use and that individuals often struggle to assign kin terms to distant relatives, it is not clear that such a system exists and how it could have evolved. Overall, it would have been helpful had Jones shown how his system can predict unfamiliar kinship terms after receiving only partial input from an arbitrarily chosen language. If those predictions do not match with the observed terms, it stands to reason that the proposed system has only limited applicability.

Finally, Jones may be correct to suggest that even though the content of individual kin terms varies widely across cultures “the conceptual structure of kinship manifest in the grammar of kin terms is more universal – and shows every sign of being adapted for tracking genealogical connections” (sect. 5.2). However, it does not follow without further argument that a universal grammar of kin terms exist. Just as the existence of language universals has been challenged recently (e.g., Evans & Levinson 2009) it remains to be seen whether or not the suggested kinship universals exist. Given that individuals grow up in particular communities and thus encounter there one specific subset of kin-terminology the coordination problem Jones discusses (sect. 5.3) could be resolved by data-driven learning. Learning kin terminology does not occur in isolation but is embedded in a broader context of language learning. Here like elsewhere it is plausible to assume that learners rely on multiple cues to arrive at the correct solution. And, considering that kin terms only cover a very small segment of human cognition, the complexity of Jones’ proposed machinery needed to handle this segment casts doubt on the existence of innate structures that cover the complete linguistic domain.

## Space, kinship, and mind

doi:10.1017/S0140525X10001925

Giovanni Bennardo

Northern Illinois University, DeKalb, IL 60115.

bennardo@niu.edu

[www.niu.edu/anthro/faculty\\_staff/faculty/bennardo.shtml](http://www.niu.edu/anthro/faculty_staff/faculty/bennardo.shtml)

**Abstract:** In this commentary, I focus on Jones’ suggestion of a close connection between the domain of space and that of kinship. I expand on that suggestion by introducing the concept of frame of reference and show how it can possibly participate to the generation of kinship systems.

Jones makes extensive use of Optimality Theory (OT) to obtain a fresh new look at kinship as mental knowledge. OT has been typically used in the study of language, mainly phonology, but also morphology, semantics, and syntax. The successful application of OT in the study of kinship opens the possibility for Jones to speculate about general principles of human cognition.

Jones himself, though, is eager to point out that OT has fundamental limitations. In fact, he states “According to OT, constraints or constraint schemas are universal. But where do universals come from? This area of OT is not well-understood” (sect. 5.3). This very important issue about OT reminds me of what I regard as a shortcoming of Lakoff’s cognitive semantics (Lakoff 1987; 1988. For a similar shortcoming see also prototype theory, Rosch 1978). Here, fundamental organizations of knowledge are pointed out, but how these essential aspects of cognition come to be is left unexplained (Lakoff clearly points out that these organizations are rooted in our bodily structures, but he does not delineate what kind of mental processes are involved at those critical stages).

What is crucial to both approaches (Jones’ and Lakoff’s), however, is the realization (and suggestion) that spatial knowledge contributes in a significant way to the organization of other domains of knowledge, for example, kinship and others. That is, it appears that some fundamental aspects of the way in which human mentally organize knowledge about space is essentially replicated in other domains, and specifically in the conceptual structures module (see Jackendoff 2002, for mental modules; and Bennardo 2009, for the significance of space).

It is here that I see the relevance of Jones’s analyses. After taking the OT route to the analysis of kinship, he realizes (and strongly suggests) that “kin terminology, like other abstract semantic domains, such as time, change of state, and possession, borrows much of its organization from the conceptual structure of space” (sect. 5.1). This is a line of thinking that I have pursued extensively in the last decade (see Bennardo 2009) and that I find very productive in elucidating a number of cognitive phenomena besides supporting a particular mental architecture such a that proposed by Jackendoff (1997; 2002).

Space, as an ontological prime, is assigned a module of its own – “spatial representations” – in Jackendoff’s (1997) modular architecture of the mind, wherein it is connected to other modules including the “conceptual structures” one. I expanded on this proposal (Bennardo 2009) and argued for a primacy of the mental organization of spatial knowledge that is later reduplicated in other domains of knowledge, such as time, possession, traditional navigational practices, traditional religion, kinship, and social relationships. This suggestion is also supported from the evidence available in developmental psychology about the very early presence of complex spatial knowledge in infants (e.g., Mandler 2004).

Jones’ proposal, then, strikes a familiar chord within my line of thinking, and it might be of interest to slightly expand on this part regarding space. One fundamental content of the “spatial relationships” module is that of Frame of Reference (FoR) (see Bennardo 2009; Levinson 2003). Choosing a FoR, or perspective-taking, is a universal prerequisite of any spatial description. A FoR is a set of coordinates (three intersecting axes: vertical, sagittal, and transversal) used to construct an oriented space within which spatial relationships among objects are identified. There are three major types of FoR: relative, intrinsic, and absolute. A relative FoR is centered on a speaker and it remains centered on the speaker when the speaker moves; for example, when one says, “The ball is in front of me.” An intrinsic FoR is centered on an object and it remains centered on the object when the object moves; for example, “The ball is in front of the car.” An absolute FoR uses fixed points of reference, for example, north, south, east, west, as in “The town is south of the river.” And there are subtypes of the absolute that use one axis (e.g., land-sea), or even only one point (e.g., Mecca, sacred mountain). In Bennardo (2009), I labeled this latter type “radial,” wherein Ego is back-grounded and other-than-ego is fore-grounded.

All three FoRs share some minimal conceptual content like “Ego,” “field of Ego,” “other-than-Ego,” and “vectorial relationship between the two” (toward or away from). For the intrinsic FoR, the “other-than-Ego” element has a field different from Ego’s, while the other two FoRs use only Ego’s field. Focusing on Ego obtains the relative FoR, focusing on other-than-Ego (in the same field of Ego) obtains the absolute FoR.

Using conceptual organizations of space of this type – that is, FoR – would generate different kinds of kinship systems such as classificatory (with focus on sibling/s or other-than-Ego) and descriptive (with focus on Ego) (Bennardo & Read 2008). In other words, it is the fact that this complex spatial knowledge – in the form of FoRs obtained developmentally very early (Mandler 2004) – contributes to the generation of other domains of knowledge that makes an OT approach appear explanatory (in this case of kinship phenomena). In fact, any FoR, once generated, may be thought of as a constraint on the generation of other knowledge organizations in many domains, including kinship. What is clearer though in this case is the fact that we



can now see where constraints come from and how they are generated from conceptual primes, for example, Ego, other-than-Ego, vectors, and so forth (see Levinson 2003, and Lehman & Bennardo 2003, for spatial primitives).

I am convinced that works like Jones' are pushing the field of kinship in the right direction, that is, toward a deeper understanding of the working, both content and structure, of the human mind. Witness to that is the mere fact that I found myself talking about the role of space in human cognition to the readers of this commentary.

## Will Optimality Theory colonize all of higher cognition?

doi:10.1017/S0140525X10001937

Tamás Biró

Amsterdam Center for Language and Communication (ACLCL), University of Amsterdam (UvA), NL-1012 VT Amsterdam, The Netherlands.

t.s.biro@uva.nl

www.biroth.hu/

**Abstract:** To establish Optimality Theory as a framework in anthropology, or as a general model of higher human cognition, researchers have to demonstrate OT is convincing in a number of ways. This commentary summarizes some of them – based on experience obtained in contemporary linguistic OT – including factorial typologies, exact formulation of candidate sets and constraints, and computational plausibility.

By concluding that “[g]rammar could grow opportunistically, colonizing any ‘grammar-friendly’ cognitive or perceptual domain,” Jones envisages a fruitful future to OT-based approaches to culture. I certainly have shared his optimism, since I presented an attempt to apply Optimality Theory to religious rituals elsewhere (Biró, in press).

However, for this “colonizing enterprise” to be fruitful, one must establish its goal and match the strategy. OT can “conquer” anthropology and cultural studies in three different – even if not necessarily mutually exclusive – ways. Either, OT is used as a pure technique; or, an OT-based linguistic model is enlarged to also encompass cultural phenomena; or, OT becomes a general model of the underlying brain mechanisms shared by language and other realms of (higher) cognition.

In what follows, I review these three “colonizing” directions, discussing which strategies potential “conquerors” ought to follow, what pitfalls they must avoid.

**1. Optimality Theory as a technique.** To most linguists, OT is a model accounting for observed typologies. For an oversimplified example, imagine that the languages of the world belong to three types: some always stress the first syllable of the word, other languages stress the last one, and other again stress the penultimate syllable; none of them put the stress on the second syllable as a rule. This observation-based typology can be explained using three constraints: 1. prefer early stress; 2. prefer late stress; 3. penalize word-final stress. The six permutations of these three primitive constraints will reproduce exactly the three language types, and importantly, this model also correctly predicts the lack of the fourth type. (For a longer explanation, see Biró, in press; or Biró 2006, sect. 1.1.)

Similarly, if anthropologists decide to borrow OT as a technique to account for kinship terminologies, they should first list all attested types; then propose constraints; and finally demonstrate that all attested types correspond to some constraint permutation, but no permutation corresponds to an unattested type. Ideally, the number of types in the exhaustive typology is relatively low, and the number of documented cultures is large enough for the difference between attested and unattested types to be statistically significant. For the model to be convin-

cing, a few primitive constraints must explain a larger number of complex types. Only by keeping this in mind can scholars of culture avoid the quick-rise-quick-fall story so typical of many theories borrowing a method from a different discipline.

As the number of constraints grows, the number of their permutations grows factorially. Yet, software tools (among many others, OTKit by Biró, available at: <http://www.biroth.hu/OTKit/>) help exploring such *factorial typologies*. These tools force the linguist to be very concrete: the candidate set and the constraints must be explicitly defined. Unfortunately, these two basic building blocks of OT are only implicit in too many papers, including Jones'. It is even unclear to me whether he optimizes kinship terms or kinship term systems.

**2. Optimality Theory as a tool to include culture into language.** The history of anthropology in the twentieth century will probably discourage many cognitive scholars of culture from adopting yet another linguistic theory. Therefore, those choosing this second, “colonizing” direction, such as Jones, must make clear how the relation between “language,” “thinking,” and “culture” is expressed in the proposed model.

Within the OT camp, this approach corresponds to including nonlinguistic constraints into the linguistic computations, similarly to Jones, who adds vocabulary constraints based on anthropological research. However, for a linguist, the lexicon of the language is learnt and arbitrary, and it is unclear how one would apply constraints *on* the lexicon. When an adult speaker produces a sound stream for the meaning ‘mother’s older sibling’s son,’ the candidates are words in the language with already fixed meanings. True, certain logic transpires the system of kinship terminology, unlike other terminologies; and yet, do we have evidence for the distinction between a *mother* and an  *aunt*, between a *noyeh* and an *ahgahuc*, being processed differently from the distinction between a *table* and a *chair*, or between a *dog* and a *monkey*? A possible research direction for this approach would be to demonstrate: a child learning the relative importance of “matrilineal distinction” over “distance distinction” in the target language suddenly improves her performance even on previously unheard kinship terms, but no such effect is discernible with the relative importance of “four-leggedness” over “surface color” in other domains.

**3. Optimality Theory as a shared underlying mechanism.** Smolensky and Legendre (2006) demonstrate how OT can describe linguistic phenomena in a way that is not only descriptively adequate, but also computable, learnable, and most importantly, which can be implemented in a neurologically plausible network. Convinced that OT and OT-like approaches (such as Harmonic Grammar) have the potential to become a framework for research on higher cognition in general, and not only in linguistics in particular, Biró (in press) presents a model for religious rituals. Jones (2004) argued earlier for the same OT mechanism lying behind social and linguistic cognitions, and kinship constraints being neither linguistic constraints, nor technical analogues: similarly to linguistic constraints, they exemplify the general building blocks of human cognition.

This third research strategy entails that we argue for more and more cognitive domains to share OT as a formalism describing their underlying mechanism. Moreover, the interest shifts from plainly reproducing observed facts in higher cognition (language, kinship terminology, religious rituals, mathematics, arts, etc.) to other aspects of the underlying mental mechanism. For instance, to issues such as the time and memory needed to find the best candidate using psychologically realistic algorithms, or the error rate of these algorithms. It may turn out, for instance, that Harmonic Grammar is more plausible as a model than Optimality Theory, because the weights are easier to implement with (artificial or real) neurons (Smolensky & Legendre 2006), and its implementation is also less prone to error (Biró 2009).

Anthropologists adopting OT must be aware that they are aiming at a moving target: The supposedly universal theory of language currently varies from linguist to linguist. Nevertheless, I am confident

that anthropologists can contribute to establishing together a solid, OT-based model of general human (higher) cognition.

## Kinship terms are not kinship

doi:10.1017/S0140525X10001949

Maurice Bloch

London School of Economics, London WC2A 2AE, United Kingdom.

m.e.bloch@lse.ac.uk

www2.lse.ac.uk/anthropology/people/bloch.aspx

**Abstract:** The target paper claims to contribute to the conceptualisation of kinship but is, in fact, only concerned with descriptive kinship terminologies. It uses Optimal Theory to analyse this vocabulary but it is not clear if this is to be understood as a psychological phenomenon. Jones does not make clear how this special vocabulary might relate to kinship in general.

The field of kinship is broad. It concerns the representations and practices, explicit or implicit, conscious or unconscious, which are concerned with the genetic links that exist between individuals. Culture and history lead to wide variation in this field, thus genetic links may be represented saliently or not at all. They may have great significance for what people do or only little. Kinship representations may be represented as a bounded set, or be inextricably mixed with representations which have nothing to do with genetic links or allusions to these. These representations may involve speech acts or not. When they do, we find *among* such speech acts what have been called “kinship terminologies.” The sociologically most important type of kinship terminologies are terms of address such as “Dad” and “Auntie.” These terms of address do not form a closed system and cannot be understood unless taken together with other forms of address such as pronouns, names and other linguistic and pragmatic phenomena. For example, in English, parents do not normally use a kinship term of address but first names when talking to their children. Then, there is another group of terms: the so-called descriptive terms. These occur when one wants to specify a relationship. In a natural setting, the use of such terms is less frequent than it is for terms of address, and it is the descriptive terms which are the subject matter of this paper. My first point is, therefore, that the title of the paper misleads as to the scope of argument since it purports to be “human kinship” in general.

Descriptive kinship terms form a bounded set; but this fact is mere tautology because of the meaning of the English word “kinship.” Whether descriptive kinship terms form a cognitive bounded set must remain an open issue and Jones supplies no evidence that they do.

Words that can be called descriptive kinship form a variety of different formal systems. There have been a number of proposals for analysing such systems and these are well reviewed here. The proposal to use Optimality Theory for such an analysis is convincing. The question, however, is: What is the significance of this? Jones claims to, at the very least, make a contribution to the study of the conceptual structure of descriptive kinship terminology. I am not quite sure what is meant by this claim. Does it mean that speakers somehow go through the rule procedures implied by Optimality Theory when deciding which word to use? If that is the claim, then I regret that Jones presents little or no evidence for such mental procedures. The author also claims that the rule procedure for Optimality Theory explains how the child learns the proper use of descriptive kinship term. Again this may be so; but he cites no developmental study of the learning of kinship terms.

The main conclusion of the article is “that constraints are neither innate nor culturally acquired, but discovered.” This may be so; but I would have thought that none of the three possibilities exclude each other and probably all three are true.

Even, in any case, if the paper has demonstrated this, this demonstration would then apply to all those apparently systematic bits of our vocabulary (closed class forms) and the conclusion would be in no way specific to kinship. The article thus does not advance our understanding of the conceptualisation of kinship as such.

## The cognitive path through kinship

doi:10.1017/S0140525X10002050

Fadwa El Guindi

Qatar University, Doha, Qatar.

Fadwa.elguindi@qu.edu.qa

www.elnil.org

**Abstract:** Integral to the discipline of anthropology are both science and holism. The application of Optimality Theory to two partial kin terminologies narrows analysis to descriptive value, fragments phenomena, and constrains data selection, which precludes significant knowledge. Embedded in this critique is a call to move analysis from fragment to whole and from descriptive features to deeper levels of knowledge underlying kin terms, thereby leading to a cognitive path for holistic understanding of human phenomena.

Anthropology is a robust, four-field science with kinship studies at its heart. The title Human Kinship is misleading. It should be Kinship Terminology. Reducing kinship to terms and terms to linguistic referents leaves out much of the anthropology of kinship. Kin terms are minimally linguistic phenomena but contain social, cultural, conceptual, cognitive, and algebraic dimensions as well.

Human kinship is broad and multidimensional, encompassing more than selective kin terms from two cultural systems considered as linguistic referents. Jones claims that certain kin term—constraining features based on properties of Optimality Theory act as faithfulness constraints whose sequential order shifts in correspondence with a specific kinship terminology. Kin terms used are consanguineal with some mention of the affinal. Analysis of kinship terminologies, though, must link three universal forms of kinship: consanguinity and affinity and sponsorship, each of which is equally and interdependently significant to understanding human kinship. Consanguinity refers to relations conceived in some cultures as sharing the biological substance of blood, while in others (as in Arab kinship systems), it is metaphorically perceived as a human body with components linked by nerves or a central nervous system. Terms for kin group segmentation among Bedouin (Bedouin groups) are corporeal, referring to body parts (limbs, thighs, etc.) forming a whole. The central notion of *‘asabiyya*, translated in the literature as “solidarity,” introduced as a core concept in the first, still current, organized theory of kinship formulated in the 14th century by the Arab social philosopher Ibn Khaldun (Ibn Khaldun 1961), is a term referring to a state of bondness resulting from shared nerves. Only purity of breed is expressed in blood terms. All of this challenges the unsubstantiated generalization that “kinship is normally conceptualized in spatial terms,” which misconstrues the reference from Leaf (2006).

The second class of kinship, affinity, is formed by ties created through marriage. The third, which I expediently refer to as sponsorship, is universal and appears cross-culturally in different forms such as spiritual parenthood (godparenthood), adoption, suckling, blood exchange, and so forth, with evidence of its presence in ancient times. All three forms have kin terms that interestingly may differ, overlap, or supersede each other. A current, exploratory research study on suckling kinship among Qatari Gulf Arabs (El Guindi 2009–2010) suggests interdependence among terms and behaviors in all three kinship domains. The present study prebiases conclusions by only nominally utilizing

in its set of features affinal terms and altogether leaving out (perhaps due to deficiency in existing data records) the third form.

Other concerns include the following:

1. A claimed universality even though application is only demonstrated for two partial kin terminologies, English and Seneca. For instance, Faithfulness Constraint of Sex is based on a proposed Male-Female polarity. Can the devised system accommodate the many ethnographic cases of a “third sex” (Wikan 1978, among other studies)? However, the other polarity of bond-boundary has positive potential if developed further.

2. An asserted homology between kin terminologies (considered a linguistic domain) and other domains, such as spatial structure. A homologous conceptual structure enters analysis at a different level, and hence seems superfluous to the main goal of describing the differences among kinship terminologies.

3. The social and the mental dimensions are assumed to be at the same level of abstraction. Figure 1 in the target article mentions social organization and social cognition. We know that social organization exists at the level of society. But what is social cognition? Is it being claimed that cognition, too, exists at the level of society? Is it cognition of the social? Is cognition social? Or is it a Durkheimian-style, societally derived or determined cognition?

4. Ambiguity in the use of the notion of shape: “[shape] is about the structure, rather than content, of kin terms” (sect. 1). Is shape the same as form? Is form structure? If so, then conceptual structure as presented is at a low level of abstraction, quite distant from cognitive structure.

5. Producing an “account of *why* kin terminologies have the *shapes* they have” (sect. 1; emphasis added) becomes a partial description of the physical features of a particular set of data from Seneca and English kinship terminologies. A selective data pool is insufficient for conclusive generalizations and analysis of partial data does not automatically lead to understanding the whole. Nor should the whole be assumed.

6. The author generously borrows [Optimality theory (OT)] and [Utility theory (UT)] from other fields (linguistic, economics, etc.), and vocabulary such as *time*, *space*, *cognition*, *social organization*, *OT*, *UT*, *kin terms*, *shape*, *conceptual structure*, *semantic contrasts*, *constraints ranking*, *language*, *markedness theory*, *open-class*, *closed-class*, *faithfulness constraints*, *markedness scales*. These vocabulary borrowings are neither convincingly motivated nor coherently linked. They might serve interdisciplinarity, but do not serve science.

7. The stated goal that “constraint ranking defines the grammar of each language, establishing a *shared code* among speakers and listeners” (sect. 1.2; emphasis added) presumes, but does not take us onto, a road to cognition.

8. Jones claims that “In language after language, time is treated as a more abstract version of space” (sect. 1), which is substantiated by neither ethnography nor theory (see Hubert 1905). Having recently completed an ethnographically grounded monograph on the notion of time and space, I disagree (El Guindi 2008). Time and space are equally abstract notions variably manifested in different forms. Time has been theoretically dealt with in isolation from space by nonanthropologists and anthropologists alike, until the French tradition called *L'Année Sociologique* (later *Annales Sociologiques*), both school of thought and journal, linked the two. It was Henri Hubert who lifted both to the appropriate level of abstraction (see El Guindi 2008, pp. 32–35, for full discussion of this development). His ideas formed the foundation for my building a new theory of Islam (El Guindi 2008) based on the concept of rhythm as it penetrates time and space.

Human systems are complexly integrated. It is difficult to see how deploying OT by identifying a sequential list of features reordered to describe kin terms of two cultural systems will lead to understanding human cognition. To advance understanding kinship terminologies, we cannot lose sight of anthropology's holism. I argue that analysis of any sociocultural domain using an abstract conceptual structure with generative, processual properties embedded in cultural knowledge will lead more productively to a cognitive path (El Guindi 2006).

## Why do we need to coordinate when classifying kin?

doi:10.1017/S0140525X10001950

Drew Gerkey and Lee Cronk

*Department of Anthropology & Center for Human Evolutionary Studies, Rutgers University, New Brunswick, NJ 08901-1414.*

agerkey@eden.rutgers.edu

lcronk@anthropology.rutgers.edu

anthro.rutgers.edu

**Abstract:** We suggest that there are two coordination games when it comes to understanding kin terminology. Jones' article focuses on the linguistic coordination inherent in developing meaningful kin terminologies, alluding briefly to the benefits of these kin terminologies for coordination in other domains. We enhance Jones' discussion by tracing the links between the structure of kin terminologies and their functions.

Jones hypothesizes that the grammar faculty is an adaptation for playing coordination games (sect. 5.3, para. 6), allowing an individual to discover constraints, match his or her own constraint rankings with those of other speakers, and generate mutually intelligible classifications of kin. Jones does not fully develop an evolutionary account that explains why human propensities for coordination games should be applied to the domain of kinship, however. In other words: Why do we need to coordinate when it comes to classifying kin?

Evolutionary explanations of human kinship often begin with theories of kin selection (Hamilton 1964). As cultural anthropologists often remind us (Sahlins 1976), however, kin terminologies rarely classify kin in ways that correspond with genetic relatedness. As a result, many cultural anthropologists see kin selection – and evolutionary theory more broadly – as irrelevant to our understanding of human kinship (McKinnon 2005). Focusing on the role of coordination games in the structure and function of kin terminologies may provide a solution to the apparent disparity between the ways that kin terminologies define relatedness and the evolutionary advantages of nepotistic behavior.

Several researchers, including Jones himself (2000), have emphasized how kinship enables individuals to identify common interests and coordinate their actions accordingly (Chagnon 2000; Cronk & Gerkey 2007; Fox 1979; Irons 1981; Van den Berghe 1979). We suggest that there are actually two coordination games when it comes to understanding kin terminology. The first game determines whether two individuals can arrive at a mutually intelligible and agreed upon term for different kinds of kin. This is simply a specific instance of the broader coordination game presented by language in general (Hume 1740; Lewis 1969; Sugden 2004). The second game builds on the shared meaning of kin terms by combining them with cultural norms and values that inform how two individuals should act toward kin. Jones focuses primarily on the first coordination game and alludes only briefly to the second. Exploring the relationship between these two coordination games may provide a more comprehensive understanding of the structure and function of kin terminologies.

Efferson et al. (2008) demonstrated that individuals can spontaneously use symbolic markers to solve coordination problems. Although these markers were arbitrary at the start of the experiment, they acquired meaning and became reliable guides for solving the coordination problem when two conditions were met: (1) individuals differed from one another in an important but unobservable way, and (2) individuals were allowed to choose markers freely and flexibly (p. 1848). Efferson et al. note that the conditions enabling symbolic markers to serve as guides for solving coordination games should apply “whenever people have a shared interest in distinguishing among themselves in terms of their unobservable information” (p. 1848). Identifying kin and interacting with them often requires a significant amount of coordination, and kin terminologies may allow related individuals to distinguish among themselves in the way that Efferson et al. describe.

Although there is evidence suggesting that kin can to some extent recognize one another without kin terms or other symbolic markers (Lieberman et al. 2007), there are many important ways in which related individuals differ from one another that are difficult or impossible to observe. Genetic relatedness is one such trait, but, as Jones rightly emphasizes, there are others. In human social groups, where kinship is often inextricable from economic, political, religious, and reproductive affairs, an individual's sex, age, rank, descent group, and alliances may be as important as genetic relatedness, if not more so. This is because the kinds of coordination problems that humans need to solve involve complex calculations of costs and benefits in multiple currencies that eventually have consequences for reproductive success.

The next step is to investigate how kin terminologies help individuals solve coordination problems beyond the domain of classification. Alvard and Nolin's (2002) research on cooperative whale hunting in Lamalera, Indonesia, shows how kinship can help people solve coordination games. In Lamalera, descent groups coordinate whaling by providing the equipment, skill, and labor that lets individuals earn greater returns for their effort than solitary productive activities. Whaling crews are composed of related individuals, but Alvard (2003) has shown that descent group membership better predicts the composition of whaling crews than genetic relatedness. Unlike genetic relatedness, which varies from individual to individual in a whaling crew, descent group membership can be the same for all members. Interestingly, research by Nolin (2010; in press) shows that the subsequent distribution of whale meat in Lamalera follows genetic relatedness between households. Lamalera whalers use descent groups defined by kin terminologies to solve the coordination game of whaling, and then they use the logic of kin selection to spread the spoils.

If humans possess an adaptation for solving coordination games, we should expect this adaptation also to apply in contexts that do not necessarily involve kin. Efferson et al.'s experiments with symbolic markers support this idea, and there is evidence from other approaches, as well. Cronk (2007) conducted experiments in Kenya with trust games that were framed with a reference to *osotua*, a need-based gift-giving relationship among Maasai. Maasai participants responded to the framed games in ways consistent with the central principles of *osotua*: They were attuned to signs of need, transferring more money when the other player appeared to need help.

Given that Maasai are familiar with the *osotua* concept, it may not be surprising that the *osotua* framing influenced how they played the game. However, when the experiment was conducted with Americans who were learning about *osotua* for the first time, the results were nearly identical (Cronk & Wasieleski 2008). This quick adoption of *osotua* norms and values may stem from a broader human susceptibility to being influenced by cultural norms that facilitate coordination. If solving coordination problems has been important throughout our evolutionary history, then we may have developed an alertness for and ability to quickly adopt such norms.

## Kinship terminology: polysemy or categorization?

doi:10.1017/S0140525X10002062

Lotte Hogeweg, Géraldine Legendre, and Paul Smolensky

Cognitive Science Department, Johns Hopkins University, Baltimore, MD 21218.

hogeweg@cogsci.jhu.edu

legendre@jhu.edu

smolensky@jhu.edu

<http://web.jhu.edu/cogsci/people/faculty/Legendre/>

<http://web.jhu.edu/cogsci/people/faculty/Smolensky/>

**Abstract:** The target article offers an analysis of the categorization of kin types and empirical evidence that cross-cultural universals may be amenable to OT explanation. Since the analysis concerns the

structuring of conceptual categories rather than the use of words, it differs from previous OT analyses in lexical semantics in what is considered to be the input and output of optimization.

A hypothesis of the target article is that grammar – as conceived in Optimality Theory (Prince & Smolensky 2004) – is a general cognitive capacity underlying cognitive universals in a range of cognitive domains  $\mathbb{D}$ ; the test case is  $\mathbb{D}$  = kinship terminology. Because we find the target article unclear or ambiguous on a number of key points, and because OT's route to defining a  $\mathbb{D}$ -theory – call it  $\mathbb{T}$  – is abstract and unfamiliar, we reformulate the hypothesis, through a concrete metaphor involving three machines.

To determine the name of Mother's Sister in Seneca, we begin with machine  $\mathcal{C}$ , which displays the genealogical tree of Figure 2 of the target article (omitting shading and labeling). We select the Mother's Sister node of the tree; the machine produces an indigo card  $I$  containing a bit-string of  $n$  0s and 1s. Next, on the machine  $\mathcal{G}$ , we insert indigo card  $I$  after setting a dial to "Seneca";  $\mathcal{G}$  produces an orange card  $O$ , also containing a string of  $n$  bits. Finally, on machine  $\mathcal{V}$  we insert orange card  $O$  after setting a dial to "Seneca";  $\mathcal{V}$  responds with a word through its loudspeaker (*noyeh*).

$\mathcal{C}$  is conceptual structure, which is universal (= not language-particular):  $\mathcal{C}$  has no dial. Theory  $\mathbb{T}$  provides  $\mathcal{C}$ 's genealogical graph, the types of nodes, and so forth.  $\mathcal{C}$  produces an indigo card  $I$  in a universal alphabet. Each symbol on  $I$  corresponds to the  $+(1)$  or  $-(0)$  value of a feature  $f_k$  (e.g.,  $\pm$ female).  $\mathbb{T}$  specifies the universal mapping from the tree on  $\mathcal{C}$ 's screen to the bit-string of feature values on card  $I$  – defining the universal feature-set  $\{f_k\}$ .

$\mathcal{G}$  is an OT grammar, which receives indigo-card-input  $I$  and produces orange-card-output  $O$ . The bit-string on  $O$  depends on  $\mathcal{G}$ 's dial setting, a language  $L$  = Seneca. The elements of  $L$  are all the different orange cards' bit-strings that machine  $\mathcal{G}$  can produce. All points of  $\mathcal{C}$  that yield the same orange card can be thought of as constituting one of  $L$ 's  $\mathbb{D}$ -categories; for example, Mother's Sister and Mother are in the same Seneca kinship category.

$\mathcal{V}$  is the vocabulary; it receives  $\mathcal{G}$ 's output, the orange card  $O$  representing a category, and, depending on the setting of its language dial, produces a distinct name for that bit-string/category. This name can then be used to refer any relation in that category; it is ambiguous in the same sense that a category name is ambiguous about which category member is being referred to.

$\mathbb{T}$  specifies the workings of  $\mathcal{G}$ . Conceptually (not computationally), each possible output bit-string is evaluated by a set of universal constraints provided by  $\mathbb{T}$ . Markedness constraint  $M_k$  ("MINIMIZE[ $+f_k$ ]") states that value  $+$  for feature  $f_k$  is dispreferred or "marked". Faithfulness constraint  $F_k$  ("DISTINGUISH- $f_k$ ") demands that  $f_k$ 's value on orange  $O$  match  $f_k$ 's value on indigo  $I$ . Constraint conflicts are resolved by ranking: Possible output  $A$  is preferred to possible output  $B$  if the highest-ranked constraint that has a preference between them prefers  $A$ . If no bit-string  $A$  is preferred to  $B$ , then  $B$  is *optimal*;  $B$  is the grammar's output  $O$ . Crucially, ranking is language-particular – determined by the  $\mathcal{G}$ 's dial.

Thus the hypothesis is that a theory  $\mathbb{T}$  of a domain  $\mathbb{D}$  can provide all these specifications: Crucially, the universal constraints in the grammar  $\mathcal{G}$  which, via OT computation, explain crosscultural patterns in the conceptual distinctions conveyed by different languages'  $\mathbb{D}$ -vocabularies.

At first sight, the outcome of optimization in kinship seems to result in polysemous terms (one word = several meanings) for different kin types. Previous OT work on polysemy has focused on the optimization of communication by means of polysemous terms (e.g., Fong 2005; Hogeweg 2009; Zeevat 2002; Zwarts 2004; 2008;). A word is assumed to correspond to a fixed set of semantic features. In production (which means word choice in this domain), the input is the meaning a speaker wants to express and the candidates are the bundles of features conflated by the lexicon of her language. Similarly, when a hearer interprets a word, the input is the bundle of features that are stored for this word and the candidates are any combination of semantic features. The optimal interpretation for a word will consist of all features in

the input that are not in conflict with the (linguistic) context. In contrast, in the target article, an input is an elementary kin type from a set shared across cultures (e.g., Mother's Sister) and the output is a kin type with fewer (or the same) marked feature values (e.g., Mother), entailing that the complex and simple type share a term: *noyeh* in Seneca. It appears that *noyeh* is not polysemous – it simply refers to Mother, but can be used to refer to Sister's Mother because this latter type has first been “reduced” to the first type. From the perspective of the hearer this view would be problematic when the intended meaning was the more complex type: It is not clear by what process a hearer could arrive at the interpretation Sister's Mother upon hearing *noyeh*.

However, according to the reformulated hypothesis above, the output of the interpretation is an abstract category subsuming both Mother and Sister's Mother and the analysis concerns the structuring of conceptual categories rather than the use of words. In other words, where the optimization in the above-mentioned works takes place in machine  $\mathcal{V}$ , optimization in the target article takes place in machine  $\mathcal{G}$ . As such, optimization in kinship is simply neutralization of featural differences and, surprisingly, has more in common with previous OT analyses in the domain of phonology than with OT analysis in the domain of polysemy.

#### ACKNOWLEDGMENT

The first author gratefully thanks the Netherlands Organization for Scientific Research for its financial support.

## Conceptual structure is constrained functionally, not formally

doi:10.1017/S0140525X1000138X

Richard Hudson

University College London, London WC1E 6BT, United Kingdom.

dick@ling.ucl.ac.uk

www.phon.ucl.ac.uk/home/dick/home.htm

**Abstract:** Kinship systems are best explained functionally, in terms of the conflicting needs of the society concerned, rather than in terms of universal constraints, whether Optimality Theory or other; but OT is particularly unsuitable as it rules out taxonomies. A conceptual analysis of kinship terminology shows, not that “grammar” extends to kinship, but that general cognition has the formal power to handle grammar.

Jones argues that any kinship system has to find a balance between splitting and lumping – between the need to distinguish relatives who are different and the need to generalise about those who are similar. Needs such as these are part of any functional account of how languages change and develop (Nuyts 2007) as “stable engineering solutions satisfying multiple design constraints” (Evans & Levinson 2009). It is easy to imagine a functional account of the data that Jones lays out: of why, for example, English lumps cousins together while Seneca lumps older sisters with older female cousins. As Jones says, these differences are probably related to the social structures of the societies concerned, so we already have an explanation for them. Why, then, do we also need cognitive constraints, such as his proposed OT constraints?

One possible argument would lie in the process by which children learn kinship terminology, which, according to Jones, would be speeded up if the child knew the constraints and just had to learn their rankings (sect. 5.3). This argument would work only if constraints were innate; but Jones himself thinks this is unlikely. Moreover, we don't need innate constraints to explain how the learning of one term and its meaning might facilitate the learning of a later term. An even easier explanation is that the later term's meaning incorporates the meaning of the earlier one. For example, when a child learns to lump a mother together with her sister, as in Seneca, a concept is created that can then be recycled in lumping together siblings and cousins.

Another possible argument would be that the constraints “generate” (as Jones puts it) a limited range of kinship systems, thereby explaining why only these are found; similarly, but at the level of the individual, once a child has learned the correct rankings, the child's mind “generates” the correct meanings for the language's potential kinship terminology. But once again the explanation fails if not only the rankings but even the constraints themselves have to be learned. And once again alternative explanations are easily available: Languages have only those kinship systems that are socially useful, and children learn only the terminology to which they are exposed.

My conclusion is that general cognitive constraints on kinship terminology are redundant. Kinship systems themselves evolve under social pressures in a society and are best explained in terms of the social, communicative and cognitive benefits to individuals of learning to lump and split in one way rather than others. If kinship systems in different societies show differences, that is because different pressures apply to different human societies; and if there are limits to this variation, it is because these societies are subject to similar social pressures.

As for kinship terminology, this evolves to fit the kinship system, so once the system is explained, we are already heading for an explanation for the terminology. It's true that the fit may be imperfect; for example, there may be gaps in the terminology such as the lack of an English equivalent for the everyday German word *Geschwister*, meaning “sibling.” However, it seems unlikely that any general constraint could predict this difference between English and German. (One explanation we can't give is that a term isn't needed because the concept doesn't exist in the English kinship system; this must be wrong because we can only define “cousin” in terms of “sibling,” as the child of a sibling of a parent.)

If constraints of all kinds are redundant, there's little point in discussing the merits of particular proposals for constraints such as the OT account that Jones develops. However, it is worth pointing out one general limitation of the OT mechanism when applied to the mapping between concepts and words. At least as presented here, it seems to exclude the possibility of a taxonomic organisation of meanings. For instance, if the ranking of DISTINGUISH SEX explains why we have to distinguish mothers from fathers, how can we accommodate the term *parent*? The fact is that, at some points, languages typically give us a choice between splitting and lumping; so we can either split our mother from our father, or we can lump them together as our parents. These lumped concepts don't seem to be covered by Jones' analysis, but they play an important part in the English system because we recycle them in defining more distant relatives following the pattern suggested above for “cousin”; so an aunt is the sister of a parent and a grandfather is the father of a parent.

In spite of these reservations about the approach that Jones takes, I agree totally that “The study of kin terms . . . leads beyond kin terms to ‘fundamental structures of the human mind’” (sect 5.3). Kinship terminology has featured in some of my own work (Hudson 1996, pp. 85–88; 2007, pp. 237–38; 2010, pp. 47–50) as an example of what I call “I-society,” our mental representation of society, comparable with Chomsky's “I-language.” Like Jones, I believe it is important to consider the conceptual structures that we use for kinship, and to consider what they tell us about the mind and about language. But my argument runs in the opposite direction from his. Whereas he finds a “grammar” in kinship terminology, I find structures like those of kinship in grammar; for example, as he points out, both kinship and grammar allow recursion. Moreover, my conclusion is that if our minds can cope with the complexities of I-society, then they also have the ability, without any specialised “modules,” to cope with the complexities of language (Hudson 2009; 2010, pp. 50, 160).

In short, the best explanation for the facts of language, including kinship terminology, is not OT or any other theory specific to language, but a general theory of cognition combined with a general theory of the functional demands of communication.

## Kin term diversity is the result of multilevel, historical processes

doi:10.1017/S0140525X10001962

Fiona M. Jordan and Michael Dunn

*Evolutionary Processes in Language and Culture, Max Planck Institute for Psycholinguistics, PB310, 6500AH Nijmegen, The Netherlands.*

fiona.jordan@mpi.nl

michael.dunn@mpi.nl

www.mpi.nl/people/jordan-fiona

www.mpi.nl/people/dunn-michael

**Abstract:** Explanations in the domain of kinship can be sought on several different levels: Jones addresses online processing, as well as issues of origins and innateness. We argue that his framework can more usefully be applied at the levels of developmental and historical change, the latter especially. A phylogenetic approach to the diversity of kinship terminologies is most urgently required.

Kinship is unique as a domain of human experience for which we have a vast cultural and linguistic record. That record has languished unattended for too long, and Jones is to be commended for his attempt at reinvigorating kinship studies towards the understanding of our species-typical cognition. We have many points of agreement with the program laid out in the target article (and elsewhere: Jones 2000; 2003a; 2003b; 2004), especially with the general scientific aim of generating testable hypotheses from models and theory and seeing what the data have to say.

We agree with Jones that there are shortcomings in many approaches to kinship terminologies (sect. 2.3). None of these approaches provides a workable model that really captures what is going on in people's heads when they "do kinship" – or what goes on in speech communities when kinship terms change. Optimality Theory provides an ingenious approach to these problems, and the OT constraints that Jones proposes are for the most part plausibly motivated: They are based on universals of human experience, and they articulate human social priorities in the domain of kinship.

A weakness of Jones' account is that it is not clear about the timescale (or timescales) on which this kinship-directed version of OT operates. Within linguistics, OT is invoked at the timescale of online processing (McCarthy 2007b). Jones uses OT at this proximate level but also discusses OT as part of ultimate, "origin" explanations (cf. coordination games and the evolution of language, sect. 5.3). We question the plausibility of using OT at these two markedly different timescales and find it more satisfying to think of a generalised model operating in language acquisition and change. Kinship terminologies are semantic systems used by speech communities to coordinate social behaviours, and therefore in our view the relevant timescales at which the constraint rules of kinship operate are *developmental* – how do children acquire their culture-specific set of constraints and then employ them in the life course? – and *historical* – how do those culture-specific constraint arrangements change over time?

These two timescales are crucial components for good explanations of linguistic diversity. The variation in kinship terminology across human societies is *not* random (sect. 1) because, as Jones himself has outlined (Jones 2003a), it reflects Darwinian concerns – for example, sex, status, group membership, and so forth. There is a very small cross-cultural literature on the acquisition of kinship terminology, but developmentalists are unresolved on the relative importance of semantic complexity in kin terms versus the importance of the child's exposure to sets of relatives as referents (Benson & Anglin 1987; Ragnarsdóttir 1997). In any case, to the extent that there are reliably recurring patterns of human infant experience, ontogenetic processes may further constrain the available variation. Most important, in any society the kinship terminology has a history: Individuals are not acquiring a terminology from, and languages are not constructing a system from, a space of infinite variation. This then

immediately reduces the amount of variation that needs to be accounted for by the OT framework. Just as evolutionary developmental biologists have recognised the importance that both developmental constraints and historical evolutionary processes play in explaining organismal diversity (Breuker et al. 2006), so too are both important in understanding evolved diversity in kinship terminologies.

Evolutionary diversification produces hierarchically related taxa, and because these taxa cannot be considered independent data points, biologists have developed a range of computational phylogenetic methods that take history into account for comparative analyses. These methods have been successfully applied to linguistic and cultural evolution as well, notably with the construction of large-scale language phylogenies (e.g., Gray & Atkinson 2003; Gray et al. 2009; Holden 2002; Kitchen et al. 2009). These trees provide statistical models of population history with which we can investigate cultural evolution: Hypotheses about coevolution, rates of change, directional models, ancestral states, borrowing, and the mode of evolution can all be addressed (e.g., Gray et al. 2007; Mace et al. 2005). Many studies have focused on kinship traits (Fortunato & Mace 2009; Holden & Mace 2003; Jordan et al. 2009), and we have begun to apply these methods to kinship terminologies in Austronesian and Bantu to test sequential models of sibling term evolution that are implied by markedness theory (Jordan, in press; forthcoming). We think that Jones' program holds the most promise if combined with a comparative phylogenetic approach that is implemented at the level of language change. One productive integration would allow us to detect if the outputs of constraint rerankings over time (i.e., rule changes throughout a language family) correlate with the empirical data when phylogeny is taken into account.

The constraints Jones proposes (Fig. 3 of the target article) are relatively uncontroversial as a starting point for describing the raw conceptual material, but historical affordances will determine the nature of how these play out in different language groups. Arguments about the primacy of these basic constraints therefore must wait until the empirical work is done. We need to understand the processes that have generated the observed cross-linguistic variation; these can inform speculation about what might be species-typical. As with other domains such as colour (Kay & Regier 2003) or the human body (Majid et al. 2006) the nature of variation needs to be understood before we can make any grand or ultimate claims about universality and innateness in cognitive mechanisms. One of the attractions of the OT framework is that despite Jones' presentation it doesn't require our buy-in to any universal "atomic structures" of kinship (sect. 1). They may exist, but we don't need to appeal to them to explain the historically derived patterns of kinship terminologies across languages.

## Some facts of Seneca kinship semantics

doi:10.1017/S0140525X10001391

Paul Kay

*International Computer Science Institute, University of California, Berkeley, CA 94704.*

paulkay@berkeley.edu

www.icsi.berkeley.edu/~kay

**Abstract:** Jones's analysis of Seneca kinship semantics gets some of the facts about close relatives wrong, and his mechanism for extending the analysis to distant relatives does not work.

Jones' analysis of Seneca kinship is inadequate. He restricts his OT analysis to Ego's and the first ascending generation and within these generations to only parents, aunts, uncles, siblings, and first cousins. Seneca kinship terminology covers the infinity of possible kin

relations in Ego's and the two adjacent generations. To account for more distant relatives, Jones suggests, but does not provide, a set of rewrite rules intended to reduce more distant kin relations to those just listed. The OT analysis correctly classifies the restricted set of kin relations in Ego's and the first ascending generation to which it is applied, but fails on the close kin of the first descending generation (children, nephews, nieces). The full model, relying on the kind of reduction rules Jones suggests, cannot correctly classify the more distant kintypes.

For his OT analysis of close kin, Jones does not consider the first descending generation, that of Ego's children and nieblings (nieces and nephews). Here the OT analysis fails. Ego's sister's child is a member of Ego's matriline, regardless of Ego's sex. So according to Jones's OT constraint ranking, in which DISTINGUISH MATRILINE outranks all other relevant constraints, Ego's sister's children are classed with Ego's children. In Seneca they are not. A man's sister's child is not classed with his children because a man and his sister are of opposite sex. Matriline membership is irrelevant. The classification of a man's sister's child as a *cross* relative exemplifies a semantic distinction that governs the classification of all of the infinity of kintypes in Ego's and the two adjacent generations in Seneca. *Parallel* collaterals are merged terminologically with Ego's lineals or siblings (henceforth, for convenience, "lineals" tout court) of the corresponding generation; cross relatives are terminologically distinguished from Ego's lineals. This pervasive distinction, to which we now turn, is implicit in Lounsbury (1964) and explicit in Kay (1975).

The Iroquois cross-parallel distinction is given in (1).

(1) Lineal relatives (including siblings) are Iroquois *parallel*. Two collaterally related kintypes are *parallel* iff the furthest separated, same-generation nodes on the genealogical path connecting them are of the same sex. Collateral relatives that are not *parallel* are *cross*.

The definition is most easily unpacked in terms of the traditional terminology of English cousin numbering. The children of siblings are first cousins, the children of first cousins are second cousins; the children of  $n$ th cousins are  $(n + 1)$ th cousins. These are the "integral" cousins, cousins of the same generation. For nonintegral cousins, two relatives are  $i$ th cousins  $j$  times removed iff one is an  $i$ th cousin of a  $j$ th generation ancestor of the other ( $j > 0$ ). What counts for the Iroquois cross-parallel distinction, is the relative sex of the " $i$ th" cousins (or siblings). Iff that pair of integral cousins or siblings are of the same sex, Alter is a *parallel* relative of Ego.

Looking back at the subset of relatives analyzed by OT, mother's sister and father's brother are *parallel*, and mother's brother and father's sister are *cross* because of the relative sexes of those sibling pairs. No mention of matriline membership or of minimizing-kinterm-sets is necessary. Similarly, in Ego's generation, the first cousins whose respective parents are of the same sex are *parallel* and therefore merged with siblings; those whose respective parents are not of the same sex are *cross* and therefore not so merged. Again issues of matriline membership and/or minimizing cousin versus sibling categories are otiose. In the first descending generation, alter is classed with Ego's children (*parallel*) iff he or she is the child of Ego's same-sex sibling. Classifying in this generation on the basis of matriline gets the facts wrong.

Seneca kinship terminology extends outward from Ego indefinitely in Ego's and both adjacent generations. Jones is aware that even in Ego's and the first ascending generation classification of more distant relatives, for example, second cousins, on the basis of matriline membership doesn't work. He proposes an unspecified set of reduction rules, which, successively applied, are intended to eventually rewrite longer kintype expressions to the small set analyzed by OT. (Since the OT analysis on offer does not work for any descending generation, we must imagine a new OT analysis that works for a small subset of first descending generation kintypes, to which an infinite set of kintypes will be reduced by the reduction rules.) These rules are by definition local. "It is convenient (but maybe not absolutely necessary) to assume that, with each move,

at most one pair of *adjoining elementary kin types* changes" (sect. 4.1, emphasis added). The single example given reduces a genealogical path by application of two rules, each replacing two adjacent nodes with a single node that shares either the sex or the generation of one of the nodes it replaces. But no set of such local rules can account for the Seneca cross/parallel facts because the Seneca cross/parallel distinction is based on the relative sex of two arbitrarily separated nodes, the two most distant same-generation nodes. For example, Ego's father's mother's father's mother's brother's daughter's son's son's child is terminologically classed as Ego's sibling because Ego's father and alter's father are of the same sex. Nothing else matters.

One could of course imagine rewrite rules that looked at nonadjacent nodes. Or one might perhaps add some condition(s) on strictly local rules that would have this effect. But any such moves would just come down to a needlessly complicated notational equivalent of the definition of Iroquois cross-parallel given in (1). That definition effects the accurate classification of all Seneca kin in the relevant generations, without recourse to (a) separate formalisms for close and different kin, (b) ordering of constraints (OT), or (c) reduction rules. No set of local reduction rules of the kind Jones hints at can do the job because the key dependency is nonlocal. Additionally, the OT analysis of the finite subset fails on the facts in the first descending generation. The rejected model, I'll ol' componential analysis, gets the whole job done accurately with less machinery (Kay 1975; Lounsbury 1964).

## Language and kinship: We need some Darwinian theory here

doi:10.1017/S0140525X10001974

Chris Knight

Professor of Anthropology, Comenius University, Bratislava, Slovakia.

chris.knight@live.com

www.chrisknight.co.uk

**Abstract:** Common to language and kinship is digital format. This is a discovery, not an innate feature of human cognition. But to produce a testable model, we need Darwinian behavioural ecology.

Kinship rules and linguistic rules, notes Jones, "are intriguingly similar in form." In each case, we have not graded and correspondingly disputable meanings but sharp digital contrasts and correspondingly abstract logical computations. To explain this, the author initially posits an "innate conceptual structure of kinship" interacting with the language faculty's "optimal grammatical communication" principles. Toward the end of the article, however, this idea is abandoned. "The alternative," the author now explains, "is that constraints are neither innate not culturally acquired, but discovered." Humans are equipped neither with an innate Kin Term Acquisition Device nor with a hard-wired Language Acquisition Device. Instead, the relevant hard-wiring has a broader function: It equips us to play "coordination games."

The idea has support among many evolutionary psychologists and anthropologists. What's needed here, however, is some Darwinism. If we're to come up with a testable model, we need to specify at least some details of the "coordination games" we envisage our evolving ancestors to have been playing. Sex isn't just in the head, any more than are costly burdens such as pregnancy, birth, lactation, or childcare. Behavioural ecology is the relevant discipline here, dealing as it does with the costs and benefits of real biological strategies operating in the real world.

At some point during the evolution of our species, sex and reproduction became subject to the rule of law (Knight 2008; 2009). Like any legal system, a formal kinship system is designed to minimize scope for disputation: It does this by eliminating shades of grey. You are either a sister or a wife; to a relative of the opposite sex,

you can't be somewhere in between. Jones understands that this principle – critical to both language and kinship – is a “discovery” and not a consequence of cognitive hard-wiring. If humans are to coordinate their efforts in defining and enforcing the law, they must necessarily draw distinctions in this way. To suggest this, however, is only to make a start in asking the really interesting questions. Who initially benefited from this extraordinary development? Did males drive the whole process, as Lévi-Strauss (1969) suggests? Or were females actively involved? As soon as sex differences are taken into account, we can start constructing a model detailed enough to be testable in the light of archaeological, ethnographic and other evidence.

## Conceptual implications of kinship terminological systems: Special problems and multiple analytic approaches

doi:10.1017/S0140525X10001408

David B. Kronenfeld

*Department of Anthropology, University of California at Riverside, Riverside, CA 92521.*

[david.kronenfeld@ucr.edu](mailto:david.kronenfeld@ucr.edu)

[pages.sbcbglobal.net/david-judy/david.html](http://pages.sbcbglobal.net/david-judy/david.html)

**Abstract:** I raise issues concerning Jones' Seneca analysis, its relationship to analyses of Dravidian-, Crow-, and Omaha-type systems. These affect the convincingness of his kinship study, and thus the wider conclusions that he wants to draw regarding human cognition and language.

It is always interesting to see a new approach emerge – especially in an area as long studied as kinship terminologies. Our understanding of terminological systems has benefited from the multiple and diverse perspectives represented in the analytic work of Lounsbury (1964a; 1964b), Romney (1965; Romney & D'Andrade 1964), Read (2001a), and Gould (2000), among others, and I hope comparable contributions will come from Jones' approach. But for that contribution to be realized some further information is needed, beyond what is in this paper. In what follows I highlight some of the major needs.

First, major innovative contributions in this area have come out of detailed formal treatments of complete systems – versus only illustrative examples. Jones does provide such an account for part of Seneca, but not for the part that is most distinctive and of most theoretical interest – the range of cousins out beyond what we call first cousins. He does address the issue, but only in a thin programmatic way – a way whose success does not seem inevitable or obvious.

Second, the Seneca detail is important because it is in that detail that Iroquois-type systems (including Seneca) differ from Dravidian-type ones. And that difference is very important because Dravidian-type terms (and thus cross/parallel determinations) map cleanly onto some social groups such as moieties, while Iroquois-type ones absolutely do not (see Lounsbury 1964a). In this sense, “matriline” (sect. 4.1) seems much more relevant to Dravidian than to Iroquois. In a paper such as the present one, complete analyses of a number of contrasting systems is too much to ask, but one would like to have seen some illustrative detail concerning how the two types would each be dealt with, and thus the two distinguished.

Third, a similar problem is posed by Crow- and Omaha-type systems (sometimes spoken of as “skewed” systems) in which basic kinterm categories systematically cross generational lines (see Lounsbury 1964b). The comment about lowering the rank of DISTINGUISH GENERATIONS in note 4 does not do it, for the same reason that the treatment of Seneca cousins did not.

Finally, there is the “what does it buy you?” question. The relevance of the paper to the linguistics and universals of thought issues that open and conclude the paper depends on the success of the kin terminology analysis. What is the task whose success is

at issue? That is, we already have in kinship approaches that represent semantic contrasts, approaches that model native speaker calculations, approaches that facilitate cross-system regularities and thus define types, approaches that clarify the relationship of terminologies to social features, and approaches that aid the inductive process of finding a system's regularities. What analytic or theoretical kinship questions does this new approach particularly speak to?

I look forward to seeing treatments of these issues in future publications.

## Pragmatic and positivistic analyses of kinship terminology

doi:10.1017/S0140525X10001986

Murray J. Leaf

*School of Economic Political, and Policy Sciences, University of Texas, Dallas, Richardson, TX 75083-0688.*

[mjleaf@utdallas.edu](mailto:mjleaf@utdallas.edu)

[www.utdallas.edu/~mjleaf/](http://www.utdallas.edu/~mjleaf/)

**Abstract:** Jones' article suggests that the anthropological analysis of kinship has followed a single line of development based on a single underlying conception of meaning and method. In fact, there have been two opposed lines of development. Jones' conception is positivistic. The other is pragmatic. Pragmatic theory is superior on every recognized criterion. This briefly describes the differences.

Jones assumes a referential theory of meaning drawn from ethnoscience and logical positivism. He cites Dwight Read and me without recognizing that we argue for a very different, pragmatic, conception (Leaf 1971; 2007; 2009; Read 2001; 2007). Pragmatic theory is demonstrably more parsimonious, precise, and powerful.

Referential theories are set up in terms of words and their referents. Pragmatic theories are set up in terms of ideas and their uses. Jones offers a list of universal parameters for classifying what kinship terms refer to and justifies it by invoking the supposed success of OT in linguistics. Read and I, by contrast, have demonstrated (not just suggested) that terminologies are systems of interrelated definitions, and that their internal order derives from computational rules contained in the core of terms that define the “direct” relations around the user, or self. Referring to relatives is just one of the many uses of such conceptual systems.

Jones begins by distinguishing two levels of language: “ordinary” and “VIP.” Ordinary is “open class or lexical,” which “includes most nouns and verbs.” He describes VIP as “closed-class” but otherwise only by example. The examples are grammatical markers. He puts kin terms in the VIP class. It is a crucial step in the argument, and it is unjustifiable. Languages have many closed classes, including classes of nouns and verbs. Kinship terminologies do form closed systems, but not classes in this sense.

Jones then argues that grammar uses spatial and temporal imagery, and this is also true of kinship terminologies. Quoting me, he notes that kinship terminologies always use spatial imagery. Such spatial categories appear to him to be innate, but their relative weight can vary. The order in which such categories dominate one another act on random linguistic (referential) variation to produce the patterns of meaning in any given terminology.

Jones' Figure 2 offers his comparison of English and Seneca. This represents only three generational levels: self, the one above, and the one below. Both terminologies define more positions than these, and more importantly both use categories that Jones's analysis cannot recognize because they are cultural and local.

In fact, terminologies can be represented comprehensively. This can be done at several levels of abstraction, beginning



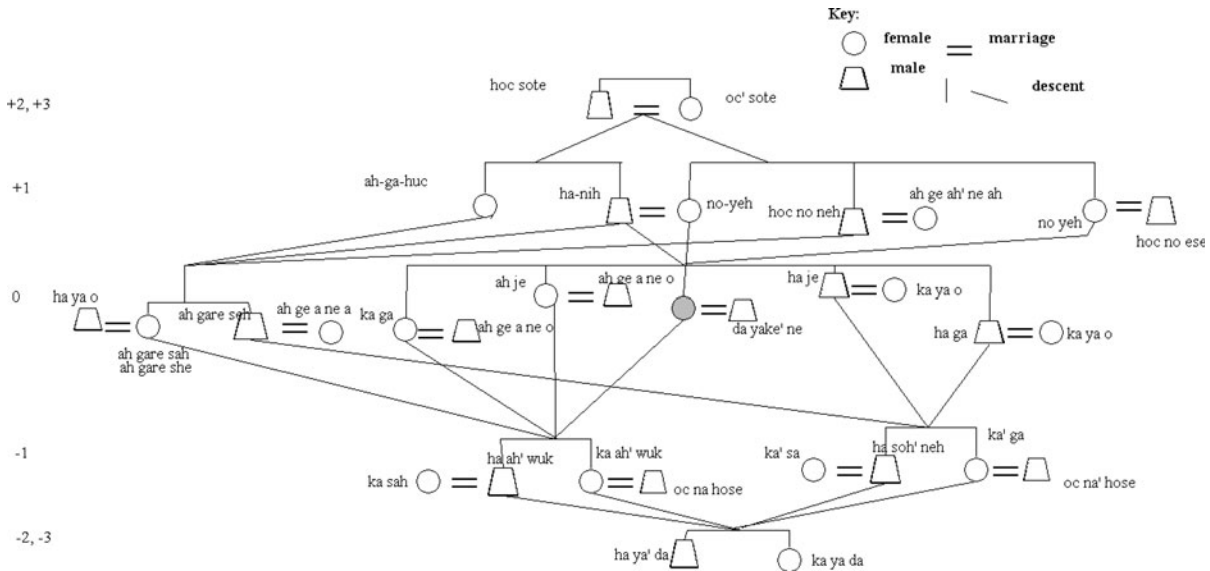

Figure 1 (Leaf). Seneca, Female Speaking

with the kind of diagram produced during field elicitation that I have called a “kinship map” (Leaf 1971) and carrying through algebraic reconstructions demonstrating their underlying generative rules. I have published the kinship map for English previously, contrasting it with Punjabi and addressing the same issues of spatial representation that are relevant here (Leaf 2006; 2009, p. 92). Read (1984; Read & Behrans 1994) has demonstrated its mathematical logic, and Read and Fischer have constructed a computer analysis that can regenerate it and any other system that is available on the Internet with the Kinship Analysis Expert System (Read 2006).

The English terminology has three important features that Jones’s analysis obscures or misses entirely, and that OT apparently cannot encompass. First, positions can be extended vertically forever: Just keep adding the prefix “great.” The same number of prefixes mark the reciprocal terms. Jones recognizes generation, but not the idea of extensibility. Second, by contrast, in the horizontal direction “cousin” is a boundary. There is no relation beyond cousin. All terminologies must logically have boundaries in order to be closed, but Jones does not recognize the problem of finding them. And third, cousin in English is actually not specific to a single generation, so generation as a constraint does not dominate all others.

Every kinship terminology defines kinship in its own specific way based on its own conceptual contrasts. There are resemblances but no precise universals. The English idea of being related is strongly associated with the idea of common ancestry. To produce it, the terms consistently distinguish lineal versus collateral relation, sex, and generation in the direct descent line only. Outside the direct descent line, the terms distinguish only whether one is a sibling or sibling-spouse of a lineal or a descendant of such a sibling-spouse. The idea of an ancestor who is not a relative is a self-contradiction.

Seneca is indeed very different. Figure 1 is the kinship map for a female self (indicated by the gray circle). I have constructed it by asking the table of terms in Morgan’s *Ancient Society* for definitions beginning with the core positions around self, just as I would have asked a group of live informants. Despite two terms that appear to be variant pronunciations of a single name, the consistencies emerge clearly.

Here, the +2 and -2 generations are boundary positions. The terms for the +3 and -3 generation are the same, although Seneca recognize individuals who are their more distant ancestors. So the second feature is that an ancestor is not necessarily

a relation. The third conspicuous feature is that positions form groups based on a specific contrast between own matrilineal clan as against all other clans – not “matrikin.” Own brothers and sisters are grouped with mother’s sister’s children and contrasted with all other relations on one’s own generation. Children of *ha-nih* (father and father’s brother) who are also children of own mother are in own sibling group, children of other *ha-nih* are in the all others group. The same logic applies on the -1 generation. Finally, the difference between the male and female terminologies is that in the male terminology own children are grouped with other children of males on one’s own generation, which Morgan does not explain but which seems to emphasize again the importance of the difference between descent through males and descent through females – as did Iroquois political organization. What the terms consistently distinguish are generation, clan, mother’s and father’s side, marital versus descent relation, sex of speaker, and sex of linking relative.

Seneca terminology embodies Seneca social conceptions just as English terminology embodies English social conceptions. Seeing how they do so brings us face to face with the cultural and social basis of thought itself. Empirically unnecessary speculation on the possibility of innate ideas is a distraction.

### Advancing our grasp of constrained variation in a crucial cognitive domain

doi:10.1017/S0140525X1000141X

Stephen C. Levinson

Max Planck Institute for Psycholinguistics, Nijmegen, The Netherlands PB 310 NL-6500 AH, The Netherlands.

levinson@mpi.nl

<http://www.mpi.nl/people/levinson-stephen>

**Abstract:** Jones’s system of constraints promises interesting insights into the typology of kin term systems. Three problems arise: (1) the conflation of categories with algorithms that assign them threatens to weaken the typological predictions; (2) OT-type constraints have little psychological plausibility; (3) the conflation of kin-term systems and kinship systems may underplay the “utility function” character of real kinship in action.

The neglect of kinship in current anthropology and in the cognitive sciences is not far short of a scandal. Humans are the

categorizing species, and kinship systems categorize our own most significant others, so reflecting fundamental forms of social organization. In small-scale societies, kinship forms the backbone of the political and economic organization, and even in complex societies, it plays a significant role (Kuper 2009). Moreover, kinship is one of two primordial foundations for relational cognition – the other being, as Jones notes, spatial relations (kinship identifies a *person* by a relation to Ego; spatial relations identify a *place* relative to a landmark, where a place is rather more abstract than a person). Advanced relational reasoning is the big divide between us and the other primates: Even our cousins the chimps have a hard time doing relational thinking (Penn et al. 2008). It is likely that language and relational reasoning are mutually implicated, although which provides the foundation for the other is controversial (Loewenstein & Gentner 2005). Many small-scale societies have such complex kinship systems that they have exercised professional mathematicians, while still being mastered by kids.

So, Jones has done us a big favor by putting kinship back on the cognitive science agenda with an interesting new twist. It has long been obvious that despite exuberant variation in the kinship systems of the world, there seem to be a limited set of underlying types (see, e.g., the important work by Godelier et al. [1998], unfortunately not referenced by Jones). Jones gives us a very neat way to think about this pattern in the diversity, in terms of differentially ranked principles for grouping and distinguishing kin. Previous approaches, such as componential analysis and reduction rule analysis (see Tyler 1969 for a range of approaches), have each captured part of the phenomenon but somehow have failed to give us an exhaustive way to think about the typology of kinship systems. A componential analysis, for example, might characterize *cousin* as +collateral, +same generation, unmarked for sex, while *brother* might be +lineal, +same generation, +male (Romney & D'Andrade 1969), while a reduction rule analysis might tell us that a mother's brother's son's son is like a mother's brother's son, so counts as a kind of (less prototypical) cousin.

Jones' system uses just eight "faithfulness constraints," or instructions, to group or individuate kin of different kinds, which are further constrained by three "markedness constraints" giving us implicational scales of the kind "if you distinguish different kinds of cousins, you should distinguish different kinds of siblings." What this actually amounts to is a way of formulating metaconstraints over componential analyses of different kinship systems. If you reorder his constraints, some distinctions will be made and others not – so you can't have all your cake and eat it too. The markedness constraints will ensure that there is, for example, a greater lumping of distant kinsmen and greater splitting of close kinsmen. The whole system of Jonesian constraints then acts to constrain the possible componential analyses available to kinship systems. This looks as though it might be a major advance in the typology of kin term systems, although it will need testing on a representative sample of the exuberant variation (if there are 7,000 languages in the world, there are 7,000 kinterm systems, even if many of these will prove isomorphic – note though that Tamil, for example, has a dozen or more distinct kin term systems adapted to the different castes: See Levinson 1977).

Now, this system doesn't capture the notion of prototype kin and their extensions, so nicely captured in the reduction rule analysis of Lounsbury (1969), and argued for on psychological grounds by Malinowski. Here Jones plans an addition to the OT framework with a recursive application of the constraints. It is hard to see exactly what the implications for typology might be, but it must multiply the possibilities enormously, so undermining some of the attractions of the OT approach. It would seem better to keep separate the *categories* from the *algorithms* that assign referents to them, for the simple reason that we know that individuals use more than one manner of assigning kin to categories (Levinson 2006). This implies that the prototype structure of kin categories should form part of the primary category structure, not part of the assignment algorithm.

A major issue though is the psychological reality of all this. This is the Achilles' heel of OT analyses, which are typically derived by detailed comparison across languages: They are thus constructed with all the metalinguistic hindsight of the (hypothetically) omniscient analyst. It is quite unwarranted (despite the normal claims of OT) to think that any one native speaker has this kind of meta-knowledge in his or her head. To learn a kin term system a child starts off by learning "names" for those around her, then grasps the relational character (other kids have "moms" too), then learns the extensions – and kin terms are one domain of language where explicit instruction and correction are common (see Hirschfeld 1989 for review). Thus an individual can learn to use the system without having an overview of how it works. Kinship systems are a wonderful example of culture as the second great invisible watchmaker – intricate systems without a designer. They are honed by cultural evolution, can be exceedingly complex like the Australian systems, and because they have to serve important social functions of regulating reproduction and social conduct, they are directly under selection by the social systems they must integrate with. Jones' constraints, if they correctly capture the typology of extant kinship systems, may do so not because the categories are antecedently in our mind, but because these are the ones that societies need to work with.

Jones' paper bristles with other interesting ideas. Particularly interesting, perhaps, is the idea that kinship systems have a digital character – unlike the analog (or gradient) nature of utility functions – because they are solutions to communicative coordination games. Here as elsewhere, Jones perhaps fails to draw a sharp enough line between kin term systems (linguistic in nature) and kinship systems (systems of reproduction, marriage, inheritance and authority). Note how the kin-selection metric (Hamilton's rule) does not map neatly onto any known kin term system – a Seneca cousin, for example, is treated as equal to Ego's sibling, even though the cousin shares 12.5% of his or her genes with Ego and the sibling 50%. In some ways the kin-term system will regulate the kinship system (e.g., in the kind of behavior appropriate to categories), but in other ways (e.g., inheritance) the two may part company. The kin-term system is part of the language and communication system, the kinship system is part of a social organization. Insofar as they are coincident, and kinship is digital, this is part of the magical power of language to construct the categories of our world (Levinson 2003).

## Exploring the conceptual and semantic structure of human kinship: An experimental investigation of Chinese kin terms

doi:10.1017/S0140525X10001366

Chao Liu,<sup>a,b</sup> Yue Ge,<sup>a</sup> Xiaoqin Mai,<sup>c</sup> and Yue-Jia Luo<sup>a</sup>

<sup>a</sup>State Key Laboratory of Cognitive Neuroscience and Learning, Beijing Normal University, Beijing, 100875, China; <sup>b</sup>Department of Psychology, University of Michigan, Ann Arbor, MI 48109-1109; <sup>c</sup>Center for Human Growth and Development, University of Michigan, Ann Arbor, MI 48109-1109.

liuchao@umich.edu

geyue818@163.com maixq@umich.edu Luoyj@bnu.edu.cn

www-personal.umich.edu/~liuchao/index.html

psychbrain.bnu.edu.cn/teachcms/luoyuejia.htm

**Abstract:** We designed an experiment to test the application of optimality theory (OT) in kinship terminology studies. Specifically, we examined the OT constraints within a set of behavioral data using Chinese kin terms. The results from this behavioral approach support and extend Jones' linguistic approach by identifying underlying cognitive mechanisms that can explain and predict behavioral responses in kinship identification.

In the target article, Jones proposed that optimality theory (OT) is a universal principle for constructing human kinship

terminology. However, his arguments focus mainly on the linguistic aspects of OT and kinship representation and relatively overlook the cognitive aspects, such as: How does the human mind process kin terms and what are the behavioral consequences of these processes? As cognitive psychologists, here we provide a discussion of the OT from a behavioral approach. Specifically, we focus on the filterlike OT constraint ranking principles Jones proposes and use an experimental design representing the kinship space to examine how the five linguistic OT constraints Jones proposes fit our behavioral data using Chinese kin terms, and how these results could modulate the constraint ranking principles.

One key feature of the OT, according to Jones, is that constraints “act as filters on randomly generated variation, with each constraint weeding out variants that violate it . . . each constraint strictly dominating lower ranking ones” (sect. 1; emphasis ours). From a cognitive psychology perspective, this assumption of serial filtering processes has big implications for how people access and process the meaning of kin terms at different constraint ranking levels. Because cognitive resources are always limited (Halford et al. 1998), kin terms filtered by constraints ranked higher should be processed differently than those filtered by constraints ranked lower, thus resulting in different behavioral patterns for kin terms that are governed by different constraint levels. We argue that this cognitive hypothesis is an important extension of Jones’ approach, allowing us to examine the cognitive mechanisms underlying linguistic OT principles.

To test this hypothesis, we proposed to (1) develop a behavioral task that can measure kinship representation; and (2) apply the task to a language with kin terms complex enough to distinguish between constraints and constraint rankings.

**Behavioral task: The Five Elements Kinship Identification (FEKI) task.** All possible kinship relationships in three generations can be represented by a schema of “kinship space” with five elements that distinguish SEX, GENERATIONS, DISTANCE and Relative age (Liu et al., submitted) (Fig. 1, left). The one element in the first generation represents the grandparent unit; the two elements in the second generation are siblings and represent parental units; whereas the two elements in the third generation are not siblings but corresponding offspring of the second generation, and represent child units. In the experiment, participants first saw this schema with only a prime unit (indicated by a circle outline) that was randomly presented around one of the five elements; then another schema was *simultaneously* shown with a prime unit and several male or female target units. The task was to orally report the kinship term representing the relationship between the prime unit and the *farthest* target unit

(e.g., four female units in Fig. 1 left represent mother, grandmother, aunt and cousin, respectively).

**Chinese: A language with complex kin terms.** Chinese has a very complicated kin term system (Kroeber 1933). In Chinese, kinships are distinguished by SEX, DISTANCE, GRADE, PATRIKIN, GENERATIONS and AFFINES, resulting in 33 kinship terms in modern Mandarin Chinese without affines. This number increases dramatically with affines and marks. For example, Huang and Jia (2000) listed 52 Chinese kin terms with affines, whereas Chen and Shryock (1932) identified a total of 270 terms with affines and marks. For decades, this complicated kinship terminology system has not received much attention from anthropologists using traditional descriptive methods. However, we argue that Chinese kinship terms provide a rich and previously untapped resource in kinship terminology studies and accordingly, in the current discussion, we use Chinese kin terms to test the filter-like OT principle.

We examined the five faithfulness constraints proposed by Jones using reaction time (RT) data obtained from 22 Chinese speakers with the FEKI task (Fig. 1, right). **DISTANCE.** RTs increased with four kinship levels,  $p < 0.001$ , which is mostly due to the Distance difference. **SEX.** Sex differences were found only in level 3, between uncle terms (*shu, bo, jiu*) and aunt terms (*gu, yi*),  $p < 0.05$ . **PATRIKIN.** Differences between Patrikin terms were found only in level 4, such that cousin terms in the father-child side with prefix “*tang-*” received faster RT than those in the mother-child side with prefix “*biao-*”,  $p = 0.09$ . **GENERATIONS and MARKEDNESS SCALES.** We found significant effects of Generations between contrasts of Grandparents vs. Grandchild in level 2,  $p < 0.05$ , and Parent’s Sibling versus Sibling’s Child in level 3,  $p < 0.01$ . These Generation effects also intermingled with Markedness scales effect. The RTs of kin terms with marks (e.g., “*wai-*outside” and “*ni-*female” for Grandchild and Sibling’s Child) were slower than those without marks (e.g., Grandparents and Parent’s Sibling). **GRADE.** We did not find significant difference between Relative age, the only Grade constraint (see sect. 3.1 of the target article) distinguished in Chinese.

As implied by the filterlike OT principle Jones suggests, kin terms governed by different constraints (e.g., DISTANCE, GENERATION, PATRIKIN, SEX and Relative age) indeed showed different behavioral patterns, although they all are distinguished in Chinese kin terms. How do these behavioral results moderate the constraint ranking principles? We suggest that constraints that yield more RTs differences should be ranked higher than those that yield fewer differences. According to the assumption of serial filtering processes, constraints ranked higher might

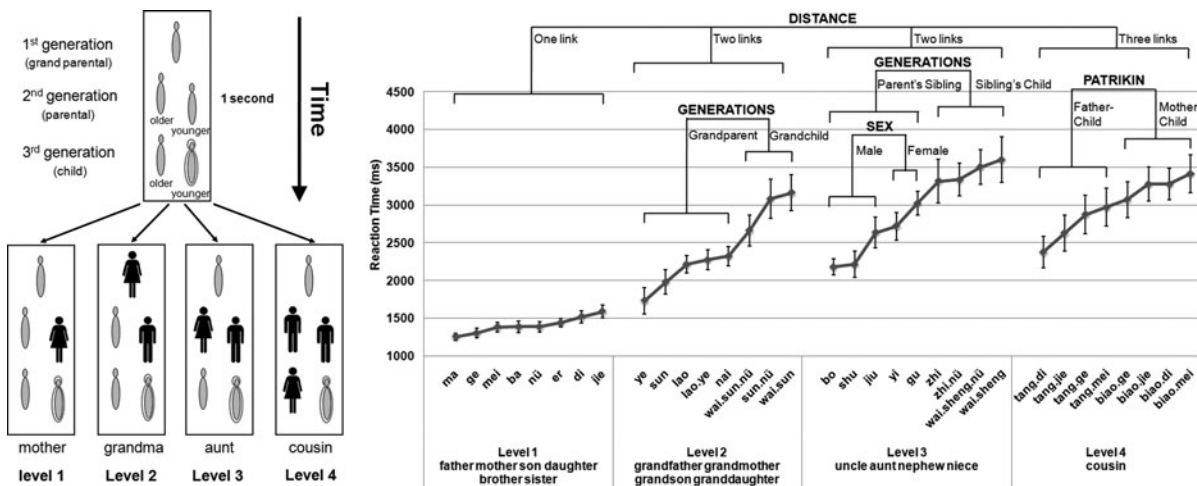

Figure 1 (Liu et al.). (Left) An illustration of the Five Elements Kinship Identification (FEKI) task. (Right) Reaction time data for 33 Chinese kin terms obtained with the FEKI task. Those constraints with significant reaction time differences were marked.

consume more cognitive resources than those ranked lower, resulting in different behavioral patterns for kin terms regulated by the former but similar behavioral patterns for kin terms regulated by the latter. Thus, the constraint ranking for Chinese kin terms, based on a behavioral approach, could be DISTANCE, GENERATION, PATRIKIN, SEX and GRADE. Comparing this result from behavioral approach with the one from the linguistic approach used by Jones may provide interesting insights into the underlying mechanism of why Jones' OT constraints work, and perhaps even how they work.

#### ACKNOWLEDGMENTS

We thank Ellen Newman for comments. This work was supported by the NSF (30930031), the Ministry of Education, China (PCSIRT, IRT0710), National Key Technologies R&D Program (2009BAI77B01), and Global Research Initiative Program, NIH, USA (1R01TW007897) to Y.-J. Luo.

## Genealogy, kinship, and knowledge: A cautionary note about causation

doi:10.1017/S0140525X10002244

Stephen M. Lyon

Department of Anthropology, Durham University, Durham DH1 3LE, United Kingdom.

S.M.Lyon@durham.ac.uk

www.dur.ac.uk/s.m.lyon

**Abstract:** The choice of emphasis in kinship studies has often resulted in incompatible theoretical models of kinship that are mutually undermining and contradictory. Jones' attempts to reconcile disparate approaches to kinship using OT is useful, however; seeing kinship as a specialized system for representing genealogy may be unwarranted in the light of recent advances in mathematical approaches to kinship terminologies.

Jones' contribution to kinship is remarkably persuasive and coherent. He draws together relatedness-centric approaches to kinship (for example Carsten 1997) with what might be understood as more mathematical or formal approaches to kinship (see for example Goodenough 1965; Read 2001). Within sociocultural anthropology there seems to be something terribly attractive in seeing and understanding the use of kinship as merely an adjunct of relatedness in some fuzzy and poorly defined situational sense. Jones astutely deals with the mathematical regularity that appears to be pervasive in kinship terminologies while attempting to account for empirically demonstrable inconsistency and ambiguity in kinship instantiation.

It is logical and predictable that simple (and self-consistent) systems produce complex, inconsistent clusters or relationships; however, the reverse is highly improbable and perhaps impossible. Jones is well aware of this and skillfully suggests that the innate conceptual structure of kinship (the part with the demonstrable mathematical regularity), is subject to principles of optimal grammatical communication present more generally in language. Optimality Theory (OT), Jones argues, renders inconsistency in observed usage comprehensible despite what would appear to be strong restriction on the range of algebraic models present in real societies. Kinship is of course not alone in demonstrating that persistent conceptual structures may be modified by grammars of communication.

Jones makes an intriguing argument about kinship borrowing its conceptual structure from that of space; however, rather than being useful for describing physical space, kinship-space is a specialized genealogy-representing tool. Jones seems to be making a similar argument to Bennardo (2009), except that whereas Bennardo begins with space and attempts to demonstrate how culturally specific conceptual models of space are fundamental to a broad range of knowledge domains, Jones instead appears to begin with kinship and notes the pervasive spatial

referents that appear to form part of the logic of kinship itself. Bennardo's work has the advantage of more elaborated formal models of space, while one of the great strengths of Jones' contribution lies precisely in his attempt to reconcile radically different analytical conceptualizations of kinship.

While I must admit to being largely persuaded by Jones' masterful analysis, nevertheless, there is perhaps one important point of concern worth noting. The conflation of kinship with genealogy has a very long history within anthropology (going right back to Morgan and arguably earlier), and while Jones is very careful to avoid any clumsy conflation, he nevertheless argues somewhat forcefully that kinship systems are spatially informed conceptual systems that are highly specialized for representing genealogy. It is self-evident that kinship is used by people for ordering genealogical relations; however, there seem to be some dangers in such an argument. First, that genealogy somehow becomes reduced to reproduction and subsequently to possibly misleading sociobiological arguments about simplistic Darwinian forces operating on kinship via genealogy. Following from this, the risk that correlation coupled with longstanding folk beliefs about kinship result in erroneous attributions of causation. Unquestionably, there are constraints on kinship just as there are constraints on genealogy, but perhaps it would be more accurate to say that genealogy takes the form it does *because* of the particular form, or structure, of kinship systems, which are themselves the result of fundamental constraints on ordering, or relation-creating knowledge systems produced by human cognition.

Attempting to understand genealogical ordering through an analytical set of terms a priori assumed to be organizationally homologous is precisely the problem that leads to the unease with kinship studies in the first place (see Leaf 1979 for a more fulsome discussion of the move away from rigorous formal approaches to kinship). Read (2006), Fischer and Read (2005), and Leaf (2005) have recently demonstrated that a number of kinship terminologies can be produced without reference to any notion or instance of genealogical relatedness. In other words, the kinship terminologies themselves are constrained by something that has *no need* for any reference to genealogical relatedness. This, then, renders the idea that kinship is somehow a highly specialized system for representing genealogy more than a little problematic. If the system can be produced *without* reference to genealogy then it seems at the very least one must consider that genealogies take the forms they do because of the independent kinship terminologies used by the societies in which they are produced.

Finally, one might, following Bennardo, make a similar case for notions of space arguably being independently constrained by more rudimentary principles of reciprocity and recursion and suggest that it is indeed genealogy that is the entirely dependent variable in the equation. Such a concern, to be sure, does not negate the significance and utility of Jones' application of OT to make sense of a more comprehensive view of social ordering in societies; rather, it suggests that while Jones is right to try to make sense of such phenomena in their entirety, he may inadvertently reinforce a demonstrably unsound assertion that genealogy is somehow driving kinship terminologies.

## Getting the constraints right

doi:10.1017/S0140525X10001998

Patrick McConvell

Australian National University, Canberra, ACT 0200, Australia.

Patrick.McConvell@anu.edu.au

**Abstract:** While the idea of applying Optimality Theory to kinship has potential, this commentary draws attention to problems with the constraints proposed. Particularly, DISTINGUISH MATRIKIN appears to recapitulate an error of linking matrilineal descent to Iroquois kinship too closely and more generally mixing descent with true kinship parameters.

Applying Optimality Theory to kinship to yield the kinds of variation between and within languages found is certainly on the face of it a good idea. The OT approach can also model change (Anttila & Young-Mee 1998), predicting which rerankings of constraints are possible diachronically, and relatedly, where two variant sets of kin equations cooccur, as in the “overlay” analysis of skewing (equations between adjacent generations; Kronenfeld 2009; McConvell, in press).

One of the key desiderata of OT is a universal and robust set of constraints. In this article, some of the constraints incorporate questionable assumptions. For example, constraints such as DISTINGUISH MATRIKIN are said to lie behind the Seneca system of classificatory kinship, with its distinction between cross and parallel kin. DISTINGUISH MATRIKIN, although not rigorously defined, appears to refer to relationships of *descent*, specifically matrilineality.

Lounsbury (1964/1969 pp.193, 210) analysing the Seneca case, refers to the “classic but erroneous anthropological view concerning the ‘Iroquois’ type of kinship systems . . . that this kind of system classifies kin by membership in unilineal descent groups.” Recognition of this error, and the strong distinction then drawn by Lounsbury between “Iroquois” and “Dravidian” systems, was a breakthrough in kinship studies, further elaborated by Scheffler (1971). It is disappointing to see a constraint apparently so closely related to this same error in this article.

Lounsbury (1964, p. 210) pointed out, “the classic [erroneous] theory predicts correctly only to the immediate (closest) uncles and aunts . . . and first cousins. Beyond this its predictions are half right and half wrong.” In this article we are initially presented with data from the immediate kin only, so the problem is not manifest. Once we go beyond that, though, we encounter contradictions between unilineal descent lines and the Iroquois/Seneca system. In an “Iroquois” system, for example, the child of female Ego’s female cross cousin is classified as Ego’s son or daughter, even though that child is not in the same matrimoiety or matriclan as Ego; presumably this violates DISTINGUISH MATRIKIN. Child of female Ego’s male cross cousin, on the other hand, is Ego’s niece/nephew (brother’s child). This pattern is in contradistinction to the “Dravidian” pattern of naming cross cousins’ children and other relations which does match well with lineal institutions.

We see some more distant kin discussion later in the target article. The application of Lounsbury style “reduction rules” to second cousins, Older Mother’s Mother’s Brother’s Son’s Son reducing to Mother’s Brother’s Son, includes a reduction of MB to F, a transgression of DISTINGUISH MATRIKIN and apparently ad hoc. This is part of the derivational apparatus imported to “fix up” OT constraints to generate correct terms for extended kin. The list of constraints used, however – prominently DISTINGUISH MATRIKIN – may be at the root of the problem. The string “Mother’s Mother’s Brother’s Son’s Son” (MMBSS) contains the same substrings “child of female Ego’s male cross cousin” (MBSS) as one of the examples discussed above. Woman’s MBSS, we saw, is classified as “brother’s son,” in an Iroquois system, hence MMBSS is reduced to MBS without resort to replacing MB by F in the derivation.

What this points to is that the relevant constraint in an OT system must directly cope with such reductions, and not miss the mark as DISTINGUISH MATRIKIN does, or have to be propped up by importation of Lounsbury-style rules. More globally, the Iroquois and Dravidian systems include many minor variants in how cross- and parallel kin are defined. There is a need for a constraint, or family of constraints, which allows for such variation to be captured by constraint rankings. The distinction between cross cousins and parallel cousins (the latter equivalent to siblings) exists in many systems, unilineal and not. In some form it is certainly a candidate for universal constraint status – the “classificatory” principle in kinship as Morgan termed it. A related constraint could be DISTINGUISH CROSS/PARALLEL. However variations on this compute the same-sex/opposite-sex metric in different ways. This is not the place to elaborate, but I am simply illustrating that different ways of implementing OT constraints in kinship are open.

Constraints should be made up of very basic transparent parameters and not draw in notions from outside that like descent. If this methodological principle is followed, it is then possible to compare occurrence of terminological patterns with other patterns such as lineal descent. If the two are combined in the basic mechanisms such comparisons are compromised.

Debate about the appropriateness of proposed constraints is going to be needed to lay a firmer foundation for the further development of this initiative. I would advocate disposing of any constraint like DISTINGUISH MATRIKIN. Its meaning is not clear, but even if it could be clarified, the patterns it is trying to explain have nothing really to do with “matrikin.”

The sections attempting to construct a place for kinship in a very broad ontogeny of cognitive patterning are less than convincing. Claims that spatial and kinship cognition are closely related universally evidently so far rest on slim foundations of some analogous structuring. In English and other European languages there is certainly to some extent a common language for these domains, but it is not clear how widespread this is in cultures, or whether cognitive behaviour in the two domains can be shown to be parallel or sharing a common basis. Once again, however, this is a research area that offers enticing prospects.

## Typological variation of kinship terminologies is a function of strict ranking of constraints on nested binary classification trees

doi:10.1017/S0140525X10002001

Paul Miers

English Department, Towson University, Towson, MD 21252-0001.

miers@towson.edu

<https://sites.google.com/site/pdmiers/>

**Abstract:** Jones argues that extending Seneca kin terms to second cousins requires a revised version of Optimality Theoretic grammar. I extend Seneca terms using three constraints on expression of markers in nested binary classification trees. Multiple constraint rankings on a nested set coupled with local parity checking determines how a given kin classification grammar marks structural endogamy.

Jones deserves enormous credit for first applying OT grammar to kin classification nearly a decade ago (Jones 2003). His latest model, however, founders when he extends Seneca terms to second cousins because he tries to conjure lineal/collateral and parallel/cross distinctions from interactions among many constraints. This strategy is surprising since he incorporated those distinctions into his earlier model, and he cites Hage (2001), who used them in binary tree representations to account for markedness relationships and diachronic change in terminologies.

Here I describe an OT-based model that does properly assign Seneca G<sup>0</sup> terms. This account illustrates what I think is at stake in Jones’s attempt to bootstrap an underlying representation (UR) for kin space.

My model’s UR is a nested set of asymmetric binary classification trees (Fig. 1). Kin types are classes defined at terminal nodes for each generational tree, and second collaterals in a descending generation are partitioned by projections from collateral terminals in ascending generations. Left-to-right precedence is fixed relative to the LIN<sup>0</sup> Ego node by the nodal dominance hierarchy. Input to the grammar can be any chunk of this nested structure and output is the surjective mapping of the input onto itself that best satisfies a strict ranking of one faithfulness and two markedness constraints: MAX, which requires expression of each input marker in the output; NOCO, which bans collateral (CO) and side markers (♀, ♂) in the output; and NOALIGN, which bans expression of side and parity markers (/, X) in the output.

There are four effective rankings of these constraints, each of which generates an optimal partitioning corresponding to one of the classification systems first proposed by Lowie (1928):

(1)

	constraint ranking	collaterals
bifurcate collateral	MAX >> NoCo, NOALIGN	//, X
lineal	NOALIGN >> MAX >> NoCo,	CO
bifurcate merging	NoCo >> MAX >> NOALIGN	X
generation	NoCo, NOALIGN >> MAX	∅

Bifurcate collateral rankings mark both cross and parallel collateral classes; bifurcate merging rankings only mark cross collateral classes and merge parallel collaterals with lineals; lineal rankings, indifferent to parity, merge all collaterals; generation rankings merge all collaterals with lineals.

Constraint rankings, coupled with parity checking, cause MMBSS (mother's mother's brother's son's son) to merge with MBS in a Seneca cross collateral G<sup>0</sup> output class (see Fig. 1). UR terminal markers define first collateral parity, but local rules determine which side marker is used to check the parity of second collaterals in descending generations. Seneca exhibits "Iroquois" rather than "Dravidian" parity in G<sup>+1</sup> (Trautman & Barnes 1998): Parity for a descendent of any G<sup>+1</sup> second collateral is determined by checking its sex against the G<sup>+1</sup> side marker that most immediately dominates its G<sup>+2</sup> parent. G<sup>0</sup> parity in both systems is inherited from the G<sup>+1</sup> parent. Since MMBSS is cross in Seneca, MMBSS is also cross. "Dravidian" parity for descendants of G<sup>+2</sup> cross types is checked against the parent kin type's contralateral side. In that case, MMBS is parallel, and the MMBSS G<sup>0</sup> descendent type can't merge with MBS.

Consistent with Hage's argument (Hage 2001), different rankings can be applied in parallel to different generations. The optimal output tree for Seneca is:

(2)

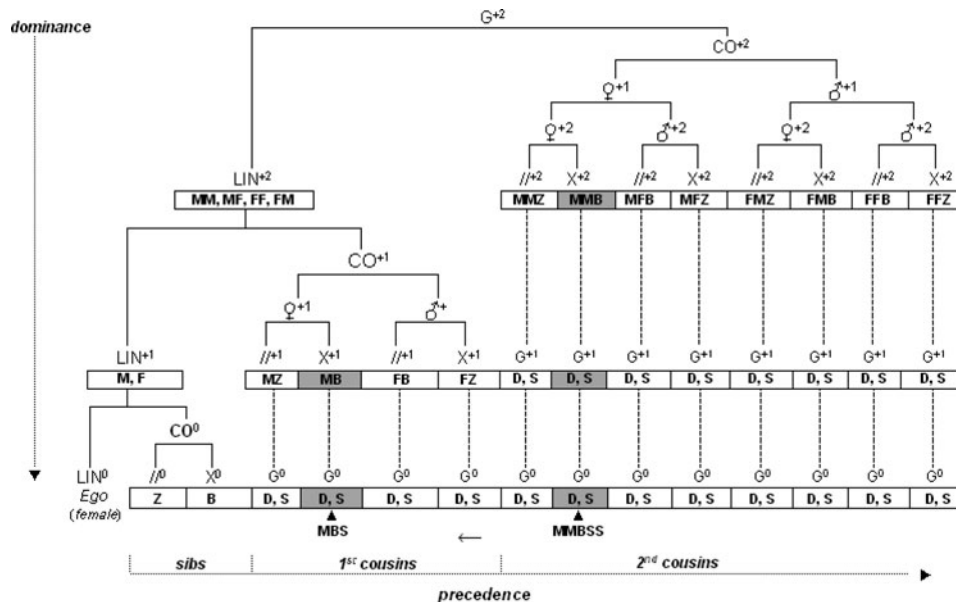
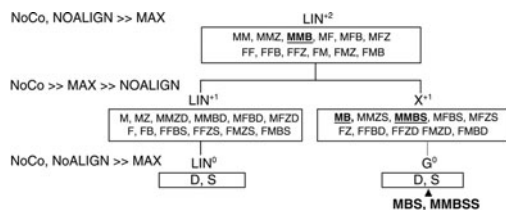
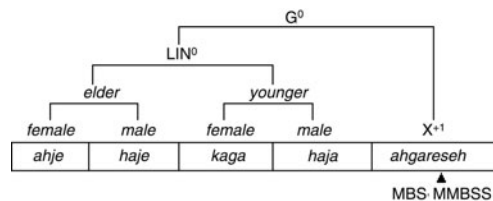

Figure 1 (Miers). Nested binary classification trees for 3G kin space: G = generation; LIN = lineal; CO = collateral; ♀ = matrilineal; ♂ = patrilineal; X = cross; // = parallel; M = mother; F = father; Z = sister; B = brother; D = daughter; S = son. Dashed lines = projections of terminal nodes.

The G<sup>+2</sup> ranking merges all collateral types with lineal types in the LIN<sup>+2</sup> class. The G<sup>+1</sup> ranking merges parallel first and second collateral types with the LIN<sup>+1</sup> class and combines cross first and second collateral types into a superordinate X<sup>+1</sup> class that occupies the position held by the neutralized CO<sup>+1</sup> marker. The G<sup>0</sup> ranking merges all child types of LIN<sup>+1</sup> parallel types in a single LIN<sup>0</sup> class and all child types of X<sup>+1</sup> cross types into a single class defined by the projection of the X<sup>+1</sup> marker onto G<sup>0</sup>.

Lexical coding trees for each generation are formed from (2). The Seneca G<sup>0</sup> tree is:

(3)



An optimal output tree partitions classes only to the level of expressed UR markers. Within-class partitionings, for example the partitioning of the LIN<sup>0</sup> class in (3), result from interaction between constraints on the lexicon and partial ordering of generations by the number of partitions in an optimal output tree. Interactions between parity checking and constraint rankings impose these partial orders. If, for example, G<sup>0</sup> parity were checked against Ego's sex and G<sup>0</sup> partitioning were determined only by a ranking rather than by a ranking and the projected X<sup>+1</sup> marker, the Seneca output tree (2) could have a different partial order. Terminological "skewing" (Lounsbury 1964) is a mechanism for subverting partial ordering. A lexical tree for the Omaha terminology (Ackerman 1976) would be a composite nested structure that projects seven classes onto G<sup>0</sup>.

Jones uses many constraints to do all the classification work because he believes the logic of human kin classification stems from a domain independent OT "grammar faculty." My model suggests a domain specific grammaticalization scenario in which a dedicated kin classification mechanism evolved to mark unilineal descent in primate social organizations (Kapsalis 2004; Strier 2004). The nested tree structure emerged as protohuman reproductive coalitions required representations marking bilateral

descent and affinity (Chapais 2008; Fox 1967). Strict ranking coupled with variable parity checking evolved as a “once and for all” solution to the problem of tracking forms of structural endogamy (White 1996) created by the extension of kinship to second and higher cross and parallel collaterals. Constraint rankings do not define marriage “rules” but rather denominate kinds of relatedness. A classification tree is thus a cognitive spread sheet used to generate reference terms for recruiting and counting social partners. An account of this model, “Structural endogamy and the grammar of human kin classification,” is available at my website.

### Kinship, optimality, and typology

doi:10.1017/S0140525X10002013

Simon Musgrave<sup>a</sup> and David L. Dowe<sup>b</sup>

<sup>a</sup>School of Languages, Cultures and Linguistics; <sup>b</sup>School of Computer Science and Software Engineering, Clayton School of Information Technology, Monash University, VIC 3800, Australia.

Simon.Musgrave@monash.edu

http://www.arts.monash.edu.au/linguistics/staff/smusgrave.php

David.Dowe@monash.edu

http://www.csse.monash.edu.au/~dld/

**Abstract:** Jones uses a mechanism from the linguistic theory, Optimality Theory, to generate the range of kin systems observed in human cultures and human languages. The observed distribution of kinship systems across human societies suggests that some possibilities are preferred over others, a result that would indicate Jones’ model needs to be refined, especially in its treatment of markedness.

The Optimality Theory (OT) mechanism Jones proposes is a universal account of the structure of kinship systems. Such OT accounts should relate to typology in two ways. First, they should be able to predict the attested range of variation in a domain using different rankings of a plausible (and, one hopes, restricted) set of constraints. Second, the markedness constraints employed should make predictions about the relative frequency of occurrence expected for the different patterns that can be generated. We explore here the quantitative distribution of kin systems and suggest that it is emphatically nonrandom in a statistically significant sense, and that at least some common patterns do not necessarily support the markedness scales proposed by Jones.

The notion of an *evaluation metric* that could select one from amongst a set of candidate grammars, so important for early work in generative grammar (see, e.g., Chomsky 1965, pp. 34–47; Chomsky & Halle 1968, ch. 9), has no relevance to the mechanism of OT. This model uses input values taken from a set of universal cognitive categories fed to a universal generative system to produce candidate output forms. The candidate forms are evaluated against a set of ranked constraints; again this is assumed to be a universal set: “The ranking in a particular language is, in theory, a total ordering of a set of universal constraints.” (McCarthy 2001, p. 6) Different outputs result from varying the relative ranking of the constraints, but none of the resulting grammars is simpler or more economical than any other; the cognitive machinery is the same in each case. The relatively small range of variation observed in phonologies, the subfield of linguistics where OT originated and has been most explored, is attributed to the fact that markedness constraints are grounded in facts about the articulation, perception, and processing of speech (Gordon 2007).

All other things being equal, Jones’s analysis would predict that no kinship system would be more economical to generate than any other; however, Jones does propose some markedness constraints which should restrict the variation. It is therefore an interesting question whether the observed distribution of different kinship systems across the cultures and languages of the world is random or not, and whether the distributional evidence supports the proposed markedness constraints.

Table 1 (Musgrave & Dowe). *Probability of the frequency distributions reported by Murdock (1970) occurring by chance (as estimated using MML techniques)*

Table Number	Kin Subsystem	Probability	Number of data points
1	Grandparents	c.8.1 × 10 <sup>-194</sup>	563
2	Grandchildren	c.2.3 × 10 <sup>-155</sup>	550
3	Uncles	c.7.8 × 10 <sup>-127</sup>	564
4	Aunts	c.3.8 × 10 <sup>-89</sup>	563
5	Nephews and Nieces	c.3.7 × 10 <sup>-58</sup>	535
6	Siblings	c.3.2 × 10 <sup>-65</sup>	561
7	Cross Cousins	c.6.0 × 10 <sup>-55</sup>	556
8	Siblings-in Law	c.1.1 × 10 <sup>-39</sup>	440

We take as a sample for analysis the kinship systems classified by Murdock (1970). This sample is accepted by Jones (2003) as the best available source and provides up to 564 data points for eight subsystems of kinship. Given that this approaches being a sample of 10% of the world’s languages, we take it as adequate for an initial exploration of the question. The results of our investigation of the data are presented in Table 1. These results were obtained using an analysis based on the Minimum Message Length (MML) principle, comparing a multinomial distribution with all classes equi-probable versus a model with probabilities inferred by MML with a uniform prior ( $\alpha = 1$ ) (Wallace 2005, sect. 5.4.2, p. 248; Dowe 2008, fn. 151). By using only these two rival models, we are being generous with our probabilities reported in Table 1.

Table 1 shows that the probability of any of the patterns in the subsystems of kinship analysed by Murdock occurring by chance is vanishingly small. Although in one case (Murdock’s Table 8) the probability is many orders of magnitude larger (undoubtedly largely a result of the smaller sample in this case), that result still represents a minute possibility. Therefore the possible variation in kinship systems is constrained.

It is not possible to comment in all cases as to how these results relate to Jones’s markedness scales, but in the cases where a direct relation can be made, the results are equivocal (see Table 2 for numerical data). For uncle and aunts (discussed in detail in Jones 2003), two patterns are almost equally common. One treats cross-kin relations as marked, with father’s brother and mother’s sister collapsed with the parent terms, while the other pattern has special terms for both the parallel and the cross-relation. The first pattern treats cross-kin relations as more marked than parallel relations, in accord with Jones’s markedness scale, but the second pattern does not. In the case of siblings, the most common pattern has four distinct terms coding both sex and seniority. In

Table 2 (Musgrave & Dowe). *Categories marked in the most common patterns for three kin subsystems*

Kin Subsystem	Pattern	Number of cases	Sample Size
Uncles	Cross-kin marked	170	564
	Cross- and parallel kin marked	151	564
Aunts	Cross-kin marked	149	563
	Cross- and parallel kin marked	151	563
Siblings	Sex and relative seniority marked	130	561
Cross cousins	(unmarked)	171	556
	Cross-kin marked	167	556

some cases, these terms may be in pairs, of which one is formally marked relative to the other; this could only be established by consulting the original sources. But it is not obvious that these data confirm Jones' view that junior kin are marked relative to senior kin. For cross cousins, one of the two common patterns does not distinguish this relation at all, while the other does. Again, only one possibility matches Jones's markedness scale. Overall, the match between Jones's markedness scales and these results is not strong.

Jones's analysis of kinship terminology using OT is promising with respect to the first of the typological goals mentioned above. His (2003) discussion shows that it generates the common possibilities in at least one subsystem. However, the simple test reported here suggests that the analysis has some work to do still to meet the second goal.

### The applicability of theories of phonological contrast to kinship systems

doi:10.1017/S0140525X10002402

Andrew Nevins

University College London, Division of Psychology and Language Sciences, London WC1N 1PF, United Kingdom.  
a.nevins@ucl.ac.uk

**Abstract:** With the goal of broadening the range of possible extant theories of phonological contrast from which kinship studies can draw, I outline, and briefly apply to the Seneca vs. English kinship systems, three approaches developed for predicting universals and variations of vowel system contrast.

Jones' proposal, that kinship systems can be insightfully handled by recent linguistic framework of Optimality Theory (OT), is laudable for modernizing the structuralist hypothesis of kinship-language homology. Both phonological and kinship systems clearly share a number of formal properties (e.g., a finite set of elements chosen from a larger contrast space; symmetric organization; differential treatment of marked categories), and kinship terms, being linguistic items, must arguably form part of any broad theory of language structure. Jones' effort falls within the program of *Cross-Modular Structural Parallelism* (see, e.g., Anderson 1992; Nevins 2010), a hypothesis which seeks to minimize differences between levels or domains of linguistic structure that are not specifically required from a difference in representational "alphabet." In effect, both the organization of a single existing system and a theory of universals and impossible systems should use the same cognitive architecture, so vowels and kinship terms will exploit the same formal mechanisms of contrast and neutralization while differing in the particular

alphabet of representations, for example, referring to features such as [+/-collateral] and [+/-cross] rather than [+/-rounded].

With the parallelism hypothesis in mind, the question becomes how to deploy the same architecture in different cognitive domains, and what that architecture specifically is. To this end, let us consider three different approaches to paradigmatic contrast and markedness, drawn from morphology and phonology. In doing so, I wish to make the main point that, despite its name, Optimality "Theory" is not in itself a specific theory of such relations or their constituent parts; it is a procedure for expressing conflict among different formal constraints. As a result, Jones' endorsement of OT as the right model from phonology for representing kinship is arguably a choice at the wrong level, similar to saying that the best word-processor for typesetting mathematical formulae is a battery-powered laptop. OT is more like a hardware into which many particular constraint software applications can be loaded.

For example, OT does not determine a phonological analysis of, say, Bulgarian unstressed vowel reduction: The "heavy lifting" of falsifiable predictions includes OT-independent decisions such as whether stress is represented in terms of metrical feet or grids; whether mid-vowels form a natural class with high-vowels to the exclusion of low-vowels, and so forth. Whether to implement these analytical claims in a monostratal, declarative, and parallel model of processing versus a serialist and procedural architecture depends on the application to particular data structures. As Jones himself says, "OT doesn't say what the rules of language are – rules differ among linguistic domains – instead, it describes how rules interact" (sect. 1).

With this in mind, recall the key phenomena Jones sets out to capture in the article: (1) markedness relations between categories – the system of contrasts expressed in one language but not another – and (2) a range of cross-linguistic variation. The example of Seneca kinship as explored in the article shows three differences from the English system:

(A) A distinction between cross cousins and parallel cousins, and a syncretism of parents and their parallel siblings. (M = MZ ≠ MB; F = FB ≠ FZ, as opposed to English, where M ≠ MZ = MB; F ≠ FB = FZ).

(B) An elder versus younger distinction in siblings (cf. English, where both are "brother").

(C) Sibling/parallel-cousin syncretism.

We turn to three frameworks developed for vowel systems and/or inventories of inflectional contrasts and their application to Seneca versus English kinship:

1. *Dispersion Theory* (e.g., Flemming 1995; see also Lindblom 1986) views contrasts and inventories as the result of system-wide pressures to minimize the number of categories crowding the vowel space, while maximizing certain important distinctions where possible. This is effectively Jones' approach to Seneca,

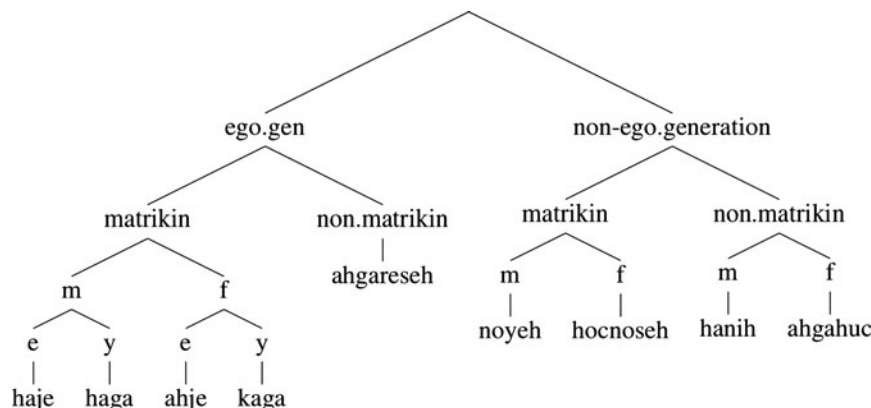

Figure 1 (Nevins). Seneca kinship contrasts under a successive division algorithm.



capturing the three properties (A–C) in terms of the pairwise constraint rankings below. Cross-linguistic variation is derived by re-ranking the same universal set of constraints, which are either of the DISTINGUISH-CATEGORY or MINIMIZE-TERMS types:

- A. DISTINGUISH MATRIKIN > MINIMIZE PARENTS' SIBLING TERMS;
- B. DISTINGUISH GRADE > MINIMIZE SIBLING TERMS;
- C. MINIMIZE COUSIN TERMS > DISTINGUISH DISTANCE.

2. *Hierarchical Contrast* (e.g., Drescher 2009; see also Goode-nough 1967 for kinship) derives an inventory from a pre-existing set of binary or privative/unary distinctions, through a successive division algorithm that halts when all terms constitute their own terminal nodes. In this approach, crosslinguistic variation emerges from the order in which features combine, or in which successive divisions are made. Seneca is captured as in the tree below.

3. *Feature-cooccurrence constraints* start with universal bans on marked categories and combinations that can be “turned off” in certain languages (Calabrese 2005; Noyer 1997; see also Archangeli & Pulleyblank 1994, and see Greenberg 1966 for kinship). Markedness is directly encoded in the definition of a feature. Crosslinguistic variation results from the options to turn on/off a universal set of neutralization rules. Assuming binary features in which the positive value represents the marked value, Seneca versus English results from certain features being “disallowed”:

Seneca: neutralize [+collateral] with [-collateral] throughout  
 English: neutralize [+cross] with [-cross] throughout  
 English: neutralize [+elder] with [-elder] throughout

Much work in phonology and morphology is devoted to comparing theories in terms of predictions for typology of possible languages, order of the acquisition of elements, and diachronic changes. These approaches differ in the data structures assumed and the corresponding discovery procedures for contrast. For example, Dispersion Theory assumes no componential features (and thus has less commitment to representational structure); Hierarchical contrast highlights the relations of contrast versus noncontrast in categories, rather than markedness; Feature-cooccurrence invokes no ranking procedure, unlike the other two. Deciding among such theories applied to kinship includes evaluating their success in expressing impossible syncretisms (e.g.,  $F = MB \neq FB$ ), as well as necessary implicational relations (e.g., a gender contrast among cousins implies one among siblings, but not vice versa). The choice among these frameworks is largely independent from implementation within an OT or other architecture. Just as OpenOffice is the same software when running on a laptop or a desktop, the theories discussed above can be plugged into OT or into a serial and derivational framework. Enthusiasm for OT does not inextricably commit one to a Dispersion approach to contrast, and nor, importantly, vice versa.

Further dialogue and research in the area of applying theories of contrast and markedness to kinship, therefore, can disentangle which predictive components are attributable to architectural principles, such as a system of ranked violable constraints and which are attributable to specific analytic components, such as systemic tension between minimizing terms and maximizing certain distinctions, or the choices involving the particular set of distinctive features defining the “alphabet” of kinship terms.

## The algebraic logic of kinship terminology structures

doi:10.1017/S0140525X10001378

Dwight W. Read

Department of Anthropology, University of California, Los Angeles  
 Los Angeles, CA 90095.

dread@anthro.ucla.edu

**Abstract:** Jones’ proposed application of Optimality Theory assumes the primary kinship data are genealogical definitions of kin terms. This,

however, ignores the fact that these definitions can be predicted from the computational, algebraic structural logic of kinship terminologies, as has been discussed and demonstrated in numerous publications. The richness of human kinship systems derives from the cultural knowledge embedded in kinship terminologies as symbolic computation systems, not the post hoc constraints devised by Jones.

Human kinship involves what it means to be kin, to act like kin, and how we are kin in a mutually understood manner through kinship relations. Kinship relations can be expressed either genealogically, by recursively tracing from one individual to another (Bennardo & Read 2007; Leaf & Read 2010; Read 2001; 2010; submitted) using parent, child and spouse relations, or by kin terms that identify categories of genealogical relations: “if there is any universal here . . . all speech communities use both category and genealogy . . . in explaining kinship to themselves and to others” (Parkin 2009, p. 165). That is, we should view “the genealogical and the terminological spaces as co-existing conceptual structures with overlap arising through application of the symbols from these two conceptual structures to the same domain of persons.” (Read 2001, p. 80; contra Jones’s misrepresentation in sect. 5.2).

But why two systems, and what is the relationship between the two systems? Jones does not address the first question and wants to answer the second by mapping genealogical relations to kin terms with OT rules. To see the problem, start with the usual answer to the first question, namely that categorization makes the combinatorial explosion produced through genealogical tracing cognitively manageable.

The categories, as we will now show, are determined through computing kin relations directly and without reference to genealogy using a *kin term product* for a pair of kin terms, K and L, defined as the kin term, M, that Ego would (properly) use for alter<sub>2</sub> when Ego (properly) refers to alter<sub>1</sub> by the kin term L and alter<sub>1</sub> (properly) refers to alter<sub>2</sub> by the kin term K (Read 1984; 2001; 2007 among others). For English speakers, the kin term product of daughter and uncle is cousin, for if you (Ego) refer to a man (alter<sub>1</sub>) as uncle and that man refers to a girl (alter<sub>2</sub>) as daughter, then you know to refer to that girl as cousin from knowledge of your kinship terminology even without knowing the genealogical relations involved.

That people in all societies compute kin relations through kin terms products is well documented through numerous ethnographic examples quoted in Read (2001; 2007). For example:

“Kinship reckoning on Rossel [New Guinea] does not rely on knowledge of kin-type strings. . . . What is essential in order to apply a kin term to an individual X, is to know how someone else, of a determinate kinship type to oneself, refers to X. From that knowledge alone, a correct appellation can be deduced. For example, suppose someone I call a *tidê* ‘sister’ calls X a *tp:ee* ‘my child’, then I can call X a *chênê* ‘my nephew’, *without having the faintest idea of my genealogical connection to X*” (Levinson 2006, p. 18; emphasis added).

This computational knowledge embedded in a kinship terminology can be made explicit through systematic elicitation of kin terms using kin term products with the kin terms for the core, structural positions in a family (Leaf 2006; Leaf & Read 2010) and displaying the structural relations among the elicited terms through a kin term map (see Fig. 1). The form of the map is terminology specific. From this map we can calculate kin term products without reference to genealogy; for example, the kin term product, nephew of grandmother, yields first cousin once removed since one goes from self to nephew in the map by the kin term product, child of child of parent, and that product takes us from grandmother to first cousin once removed.

We now construct (hence predict) the genealogical definitions of the English kin terms from the kin term map. First map the primary kin terms to their corresponding genealogical categories: mother → {m}, father → {f}, son → {s} and daughter → {d}.

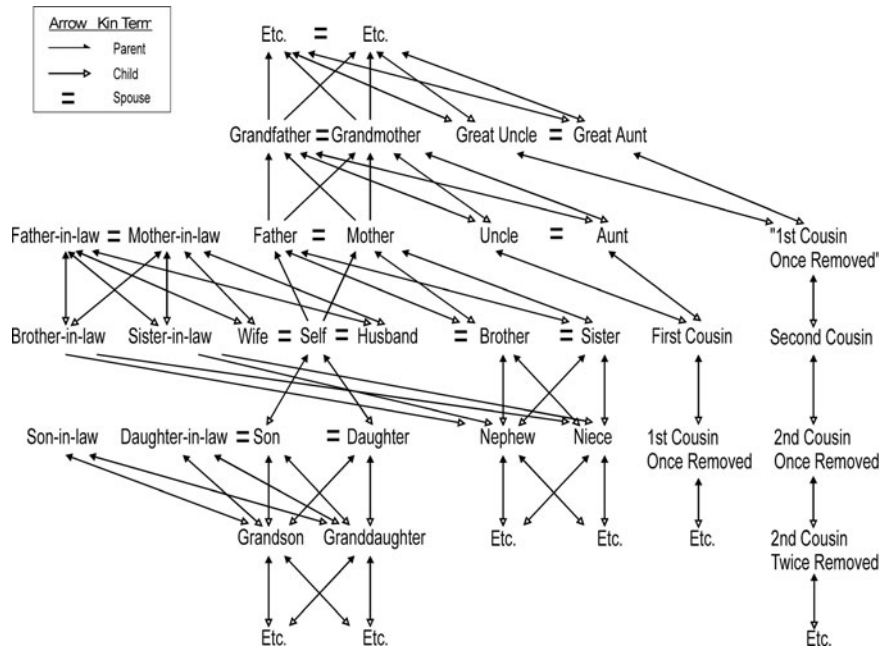

Figure 1 (Read). Kin term map for the American kinship terminology based on kin term products with the primary kin terms parent, child and spouse. An arrow indicates the result of taking the kin term product of the kin term at the base of the arrow with the primary kin term represented by that arrow. Double-headed arrows are used in lieu of a pair of parallel arrows.

Then express any kin term as a product of primary kin terms and compute the set product for the corresponding genealogical categories to determine the predicted category of genealogical relations for that kin term. For example, from the kin term map, uncle = son of grandmother + son of grandfather + husband of daughter of grandmother + husband of daughter of grandfather, so  $uncle \rightarrow \{mm, fm\}\{s\} \cup \{ff, fm\}\{s\} \cup \{mm, mf\}\{d\}\{h\} \cup \{ff, fm\}\{d\}\{h\} = \{mms, fms, ffs, fms, mmdh, mfdh,$

$ffdh, fmdh\} = \{mb, fb, mzh, fzh\}$ , where  $\cup$  is set union,  $b$  is the genealogical relation brother,  $z$  is the genealogical relation sister,  $h$  is the affinal relation husband, and genealogical strings are written in the reverse order from kin term products. Using this procedure, we obtain 100% agreement between predicted and actual genealogical definitions of kin terms (see Fig. 2). This accounts for the genealogical definitions of kin terms upon which the OT rules are based. The rules, then, are just describing

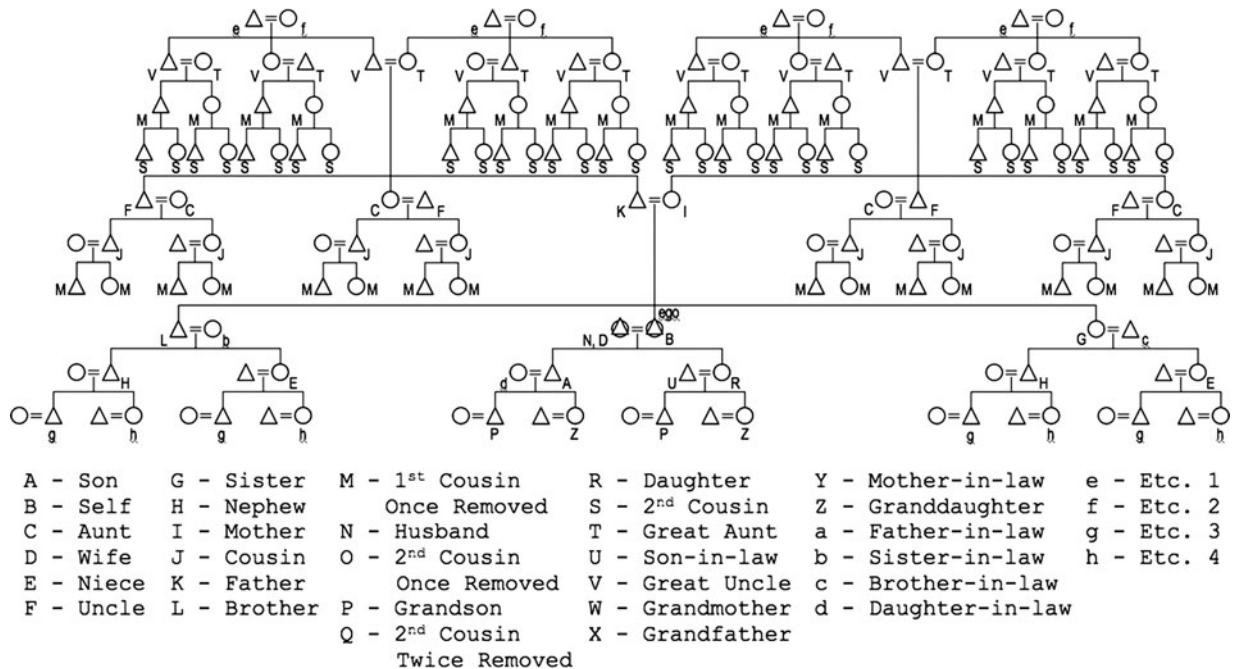

Figure 2 (Read). Predicted mapping of American kin terms shown in Figure 1 onto genealogical positions in a genealogical grid. The predicted mapping agrees perfectly with the genealogical definition of kin terms.  $\Delta$  - male marked position,  $\circ$  - female marked position, = - spouse relation, vertical line - parent/child relation, horizontal line - sibling relation. Note: 2<sup>nd</sup> Cousin Once/ Twice Removed not shown due to size of the grid.

the inverse of this fundamental mapping to genealogy determined from the cultural knowledge embedded in the system of kin terms.

Even more problematic, we may generate a kinship terminology using kin term products in accordance with established universal properties of kinship terminology structures and without reference to genealogy (Read 2001; 2007). Terminology structures begin with a core structure of ascending kin terms generated using either (1) a parent kin term as a generating term (this accounts for the properties of descriptive kinship terminologies such as the American/English terminology) or (2) a parent kin term and a sibling kin term as generating terms (this accounts for the properties of classificatory terminologies such as the Seneca terminology discussed by Jones), then expand the structure with a structure of descending kin terms isomorphic to the ascending structure (along with structural equations that define reciprocity between ascending and descending generating kin terms), then introduce sex marking of kin terms, and lastly generate affinal terms through a spouse, generating the term. The kinship terminology generated in this manner has the form of an algebraic structure, hence the use of algebraic formalism to express the underlying generative logic. The grammar of a kinship terminology lies in this generative account (see Read 2001, table 2; Bennardo & Read 2007, Fig. 1), not the OT rules as they only address the consequences of the generative logic of a terminology.

Lastly, the rules posited by Jones violate the required universality of constraints: "Optimality theory hypothesizes that the set of well-formedness constraints is universal: *not just universally available to be chosen from, but literally present in every language*" (Prince & Smolensky 1997, p. 1605; emphasis added). Jones uses terminology specific constraints (see especially Note 1) and achieves the appearance of universality only through low ranking of constraints irrelevant to a terminology. Consider the terminology of the !Kung San, a hunter-gatherer group in the northwestern part of Botswana among whom I did fieldwork. Their kin term usage depends on a name-giver-name receiver relationship established when a newborn is named for a close relative (Marshall 1976). A constraint based on the name-giver-name receiver relationship would not be universal and placing it low in the ranking for other terminologies does not make it universal. Without universality, OT rules reduce to description and hence have unclear connection, if any, to cognitive processes.

## Genealogy (and the relationship between opposite-sex/same-sex sibling pairs) is what kinship is all about

doi:10.1017/S0140525X10002025

Carles Salazar

Department of Art and Social History (Anthropology Program), University of Lleida, 25003 Lleida, Catalonia, Spain.

salazar@hahs.udl.cat

www.hahs.udl.es/hs/csalazar.htm

**Abstract:** What are the theoretical implications of a universal genealogy? After the demise of relativism in kinship studies, there is much to be gained by joining old formal-structural analysis of kinship to recent cognitive-evolutionary approaches. This commentary shows how the logic of kinship terminologies, specifically those of the Seneca-Iroquois, can be clarified by looking at the relationship between opposite-sex/same-sex sibling pairs.

The target article is a sound, original and well-argued examination of one of the most fundamental topics in the history of anthropological kinship theory. Among its numerous merits, I would single out the much-needed connection the target article

establishes between traditional formal and structural analyses, the cognitive anthropology of the 1960s, and more recent cognitive-evolutionary perspectives on the human mind and behavior in general. Many post-Schneiderian kinship studies are characterized by a relativist and social-constructivist perspective. By contrast, the target article clearly posits genealogy as the key constituent of any kinship system – not in terms of a substance (biogenetic connections) but as a structure, a system of relations (see Salazar 2009). Arguably, though the relationship between the substance of genealogy, human biological reproduction, and its structure is not contingent, the latter can be systematically analyzed independently of the former (cf. Read 2001). That is the reason kinship terms, as Jones correctly points out, may not have genealogical definitions despite being genealogically structured. I will focus my comment on what I believe is perhaps a rather specific but serious limitation in the way in which Jones' use of Optimality Theory (OT) deals with the Seneca-Iroquois terminologies.

The ranking of constraints, which appears to be one of the main characteristics of this theory, allows for greater flexibility in the identification of the distinctive features of kinship terms than the more conventional componential and reductionist/extensionist approaches. But what I see as problematic is the faithfulness constraint of "distinguish matrilin," which the author places in the second position in the ranking order. This gives rise to a number of complications; for example, if matrilin need to be distinguished, how can we explain that the Father's Brother's Son, who does not belong to Ego's matrilineage, is classed as a "brother" together with matrilineal relatives such as Mother's Sister's Son? Although Iroquois terminologies have normally been associated with matrilineal societies (despite numerous exceptions including the Yanomamo, Algonquins, Dakota, and Dogon), Lounsbury's (1964) reanalysis of Morgan's seminal work (1871) seems to eliminate the possibility of any significant connection between Iroquois equations and (matrilineal) descent. Stated otherwise, the bifurcate merging characteristic of Iroquois terminologies (merging of Father with Father's Brother and Mother with Mother's Sister) is not connected to the need to single out matrilineally related relatives. Thus I simply fail to see in what way the "distinguish matrilin" constraint makes any improvement on the more traditional cross/parallel distinction. Admittedly, as other authors have pointed out (Allen 1998; Héritier 1981: annex 1), a cross/parallel concept that can be applied equally to relatives of all three central generations –  $G^0$  (Ego's generation),  $G^{+1}$  (Ego's parents) and  $G^{-1}$  (Ego's children) – has not yet been formulated. I think this may be the case, as Jones also intimates, because this distinction derives from a more fundamental one. Contrary to Jones's argument, however, this has nothing to do with descent but with what I take to be, following Héritier (1996, pp. 62–67), the basic binary opposition observable in all kinship terminological systems: that between same-sex and opposite-sex sibling pairs, in virtue of which opposite-sex siblings are never seen as "closer" than same-sex siblings. Héritier contends, correctly in my view, that this fundamental law of kinship originates in the differential value of the sexes as is culturally recognized in all known societies. The four main terminological systems – bifurcate merging (Iroquois and Dravidian, plus Crow-Omaha systems), bifurcate collateral (Latin, Sudanese), lineal (our system) and generational (Hawaiian) – can be all seen as specific developments of the same-sex/opposite-sex sibling relationship. And even the so-called "fifth possibility," a theoretically possible but sociologically nonexistent terminological system (Hage 1997; Héritier 1981, ch. 1), is a direct result of the infringement of that fundamental law of kinship.

It would take me far beyond the scope of the present commentary to elaborate on all the implications of this elementary rule for each terminological system. Here I will focus on the Seneca-Iroquois system, which Jones analyzes as an instance of the workings of OT. In the Iroquois system, children of same-sex siblings (parallel cousins) call each other brother and sister, while children of opposite-sex siblings (cross cousins), are classed simply as cousins.

By the same token, children of same-sex (cross) cousins will call each other brother and sister while those of opposite-sex cousins will call each other cousins. In keeping with these simple rules, which clearly derive from the principle according to which same-sex siblings should be seen as closer than opposite-sex siblings, same-sex siblings are “merged” and become the parents of all their children, while opposite-sex siblings are kept separate, becoming “uncles” and “aunts” of each other’s children. These rules also account for the fact that the Father’s Brother’s Son is classed as a “brother” regardless of the matrilineage he happens to belong to, and explain why the Older Mother’s Brother’s Son’s Son is a “cousin” and not a “brother.” Both this individual and Ego are children of opposite-sex cousins: Ego’s older mother and her mother’s brother’s son. The simplicity of this principle contrasts with Jones’ argument here, which is unnecessarily convoluted. No further rules, principles or constraints are needed to generate all kin terms of the Iroquois system.

Despite this problem in Jones’ argument, his concern with disclosing “fundamental structures of the human mind” through kinship analysis is highly laudable. Further research along these lines will certainly contribute to enhancing anthropology’s position among the human sciences by deepening our understanding of the oldest, most universal and most elementary form of human relationship.

## The shared evolutionary history of kinship classifications and language

doi:10.1017/S0140525X10001421

Robert M. Seyfarth and Dorothy L. Cheney

*Departments of Psychology and Biology, University of Pennsylvania, Philadelphia, PA 19104.*

seyfarth@psych.upenn.edu

cheney@sas.upenn.edu

www.psych.upenn.edu/~seyfarth/Baboon%20research/

**Abstract:** Among monkeys and apes, both the recognition and classification of individuals and the recognition and classification of vocalizations constitute discrete combinatorial systems. One system maps onto the other, suggesting that during human evolution kinship classifications and language shared a common cognitive precursor.

Jones argues that kinship and language are similar in their discrete, combinatorial structure, and that these similarities point toward “general principles of cognition or communication.” Although he does not discuss evolution explicitly, he suggests that the shared mechanisms underlying kinship classifications and language may have evolved from the same cognitive precursor. Recent studies of nonhuman primates support this hypothesis. Specifically, they demonstrate that both the recognition and classification of individuals and the recognition and classification of vocalizations constitute discrete combinatorial systems that interact closely. One system maps onto the other, suggesting that they share underlying cognitive mechanisms. The close link between recognition and classification of individuals and vocalizations supports the view that, during human evolution, the cognitive mechanisms underlying kinship classifications and those underlying language shared a common precursor.

Although the physical features and vocalizations of different animals vary continuously, free-ranging monkeys and apes recognize each other as individuals, both by appearance and by voice. This in itself constitutes a very simple, discretely coded system of knowledge that is probably pervasive among group-living animals. Moreover, from this relatively simple starting point, monkeys, apes, and perhaps many other species make further, more elaborate classifications of individuals. Many monkeys, for example, recognize other animals’ dominance ranks. They also distinguish pairs

of individuals who have close behavioral associations from those whose interactions are less frequent and predictable (reviewed in Cheney & Seyfarth 2007). In monkeys, close bonds typically manifest in frequent grooming, support in aggressive coalitions, tolerance at feeding sites, and other behaviors. They may persist for many years. In baboons and macaques, for example, males disperse but females remain in their natal group throughout their lives, and close behavioral associations are most common among matrilineal kin – mothers, daughters, and sisters – who almost always form such bonds; but strong bonds may also occur among less closely related females, particularly when these individuals have no close kin present in the group (Schino 2001; Silk et al. 2006; 2010). In chimpanzees, females disperse but males remain in their natal group throughout their lives, and close bonds are formed between males and, more rarely, between females. Such bonds manifest in grooming, coalitions, meat sharing, and participation in hunts (Langergraber et al. 2009; Mitani 2006; Muller & Mitani 2005; Nishida 1983; Watts 1998; Wittig 2010; Wittig & Boesch 2003).

In baboons, experiments suggest that individuals not only recognize other animals’ dominance ranks and kin relations but also combine this information to create a representation of social relations in which ranked individuals are grouped into families (Bergman et al. 2003; Seyfarth et al. 2005; see also Penn et al. 2008). Observational data on Japanese macaques yield similar results (Schino et al. 2006). The classification of individuals on the simultaneous basis of kinship and rank constitutes a conceptual structure in primates because, while the individual elements may change over time as animals are born, die, join or leave the group, the overall structure remains constant. Moreover, animals treat one another differently not just because of their own behavior, but also because of their membership in a particular kin group. For example, from the moment of its birth, baboons treat an infant that belongs to a high-ranking matriline differently from the way they treat an infant that belongs to a low-ranking matriline. This difference in behavior arises not because infants behave differently but because they belong to different kin groups. In this respect, nonhuman primates’ recognition of kinship and rank can be thought of as a conventionalized system, based on discrete elements – individual identity, kinship, and rank – combined in a rule-governed manner (Cheney & Seyfarth 2007).

Nonhuman primate vocalizations also constitute a very simple, discrete, combinatorial system of recognition and classification. Most calls are individually distinctive, and individual recognition by voice is common. Many call types are also used only in particular circumstances (reviewed in Seyfarth & Cheney 2010). Baboons, for example, give acoustically different alarm calls only to particular predators, territorial calls only during encounters with other groups, screams only by lower-ranking to higher-ranking individuals, threat vocalizations only by higher-ranking individuals to lower-ranking individuals, and so on. Listeners, moreover, recognize these predictable relations. In the playback experiments cited above, where A was dominant to B, listeners showed little response to playback of the sequence “A threatens B and B screams” but responded strongly to the sequence “B threatens A and A screams” (Bergman et al. 2003). In sum, just as nonhuman primates recognize individuals and classify them according to rank and matrilineal kinship, the same animals recognize and classify vocalizations according to caller identity, context, and the “rules” of call delivery.

Jones notes that in humans, we sometimes view kinship and language as separate cognitive domains. By contrast, among nonhuman primates the recognition of individuals, kin groups, and rank relations (on the one hand) and the meaning of vocalizations (on the other) are inextricably bound together. Both are discrete, combinatorial systems, and each influences the other. When young animals learn to recognize their matrilineal kin, they do so in part by learning to recognize these animals’ vocalizations; conversely, a caller’s identity, rank, and kin group membership help to determine the meaning of a call or a sequence of calls to

a listener. When a baboon hears Sylvia giving threatening vocalizations to Hannah and Hannah screaming, the listener's interpretation of this sequence draws not only on her identification of the call types and the contexts in which they are given but also on her recognition of the callers, their ranks, and their matrilineal kin groups. In this respect, the cognitive processes involved in the recognition and classification of individuals overlap significantly with the cognitive processes involved in the recognition of call meaning. Such data offer indirect support for the hypothesis that, during the course of human evolution, the cognitive mechanisms underlying kinship classifications and those underlying language evolved from a common source.

## Lexical universals of kinship and social cognition

doi:10.1017/S0140525X10001433

Anna Wierzbicka

School of Language Studies, The Australian National University, Canberra  
ACT 0200 Australia.

anna.wierzbicka@anu.edu.au

www.une.edu.au/bcss/linguistics/nsm/

**Abstract:** Jones recognizes the existence of “primitives of conceptual structures,” out of which “local representations of kinship are constructed.” NSM semantics has identified these primitives through a cross-linguistic search for lexical universals (“NSM” stands for Natural Semantic Metalanguage and also for the corresponding linguistic theory). These empirical universals provide, I argue, a better bridge between cognitive anthropology and evolutionary psychology than the abstract constructs of OT, with dubious claim to conceptual reality.

A decade ago anthropologist Raymond Fogelson (2001, p. 41) wrote: “The study of kinship, which played such a prominent role in the development of anthropological theory, now seems to be a dead topic. . . . Only time will tell whether the subject will be revived, reincarnated, or reinvented. . . .” (See also Sousa 2003 on “The fall of kinship”).

It is to Jones' great credit that he is trying to revive this subject, which is central to the understanding of social life and social cognition. I also appreciate Jones' defence of the inherent link between “kinship” and “genealogy” (or “reproduction”) and his recognition of the existence of “primitives of conceptual structure,” out of which “local representations of kinship” are constructed (Fig. 1 of the target article).

On the other hand, I see as a weakness of Jones' account its dependence on a particular formal theory (OT) and its lack of attention to the question of metalanguage. The “constraints” approach depends on metaterms like “matrikin,” “generation,” “sex,” and “cousin,” which don't have equivalents in the languages of the people concerned and so have dubious claim to conceptual reality.

As I see it, the fundamental facts are that all languages have words for “mother” and “father”, and in all probability “wife” and “husband”, and that in all languages kinship systems are built on the bedrock of these four concepts. This fact is often obscured by the polysemy of the words in question (Wierzbicka 1992; Shapiro 2008), but Jones acknowledged it in earlier work (Jones 2004). In the target article, however, the focus is so much on theory that the empirically established lexical universals of kinship seem to disappear from view.

Jones' approach to kinship, which is wedded to OT, is vulnerable to the criticism that D'Andrade (1995, p. 30) directed at componential analysis of kinship as it was practised in the 1960s: “This type of analysis seems specialized, arcane, and formalistic.” The charge of ethnocentrism aimed at traditional anthropological analyses of kinship by, for example, Wallace and Atkins (1969, p. 364) applies as well. More recently, Leaf (2006, p. 306) noted: “The kin types were symbolized by one or two letters so

as to seem abstract and schematic, but in the end the ideas they represented were only those of the American kinship system, M or Mo for Mother, F or Fa for Father. . . B for Brother, Si or Z for sister. . . sometimes with added qualifiers for age and the like.”

Jones doesn't use symbols like M, F, B and S, but in his comparison of English and Seneca he, too, relies on kin types taken from English, such as *parent*, *sibling*, *child* and *cousin* – concepts for which there are no words in Seneca itself. Analysing Seneca kinship terminology through such terms means, I think, imposing on it a perspective alien to it.

For my part, I contend that an adequate, non-Anglocentric framework for the comparison of kinship systems can be based on empirically discovered lexical and conceptual universals, beginning with “mother,” “father,” “husband” and “wife.” In addition, such a culture-neutral analytical framework can build on the set of empirically discovered “semantic primes,” like “people,” “do,” “happen,” “body,” “before,” and 60 or so others, which, evidence suggests, can be found as words, or distinct word meanings, in all languages. (See Table 1.)

According to the findings of NSM-based investigations (Goddard 2008; Goddard & Wierzbicka 2002; Wierzbicka 1996; 2006; 2010 and many other references listed under the bibliographical links at <http://www.une.edu.au/bcss/linguistics/nsm/>), there are two sets of universal concepts: a few dozen indefinable semantic primes (“atoms of meaning”), and a smaller set of “semantic molecules” – concepts that are complex and can be defined in terms of primes but which function as units in the construction of culturally variable compound ideas. (In addition, there are many molecules that are language-specific.)

The four lexical pivots of kinship – “mother,” “father,” “wife” and “husband” – belong to the second set (Wierzbicka, forthcoming). Other semantic molecules which, evidence suggests, are universal and which are highly relevant to kinship, are the three mainstays of social cognition: “men,” “women,” and “children” (Goddard 2010; Goddard & Wierzbicka, forthcoming).

Concepts lexicalised in all languages allow us to bring hypothesized conceptual structures into the orbit of recognizable human ways of speaking; they give us an empirically grounded analytical framework that overcomes both the “technicism” of kinship algebras, old and new, and the Anglocentrism of descriptions based on language-particular English kin types.

Jones proposes rules and constraints that may make sense from the point of view of OT theorists but which are anything but “experience-near” or psychologically real. How such rules could be learned by ordinary speakers, and how they can be verified by researchers, is far from clear. It is also far from clear how formalization in terms of OT can provide a window onto “how people think about kinship” (as envisaged in Jones 2004, p. 211).

In the end, one can't help feeling that the old key questions of “psychological reality” (Burling 1967), “the native's point of view” (Geertz 1976), and “the insider's understanding” (Shore 1996) have vanished from view in the target article, amid concerns about “faithfulness constraints,” “scales limiting allowed permutations in constraint ranking,” “markedness scales,” and other similarly abstract and theory-dependent analytical constructs. As Kronenfeld (2001, p. 158) notes: “The formal analysis that best represents the regularities of the terminology may not necessarily be best at representing the cognitive operations by which native speakers navigate the system.”

The “seven faithfulness constraints” Jones proposes depend on English concepts such as “parent” and “sibling,” “sex,” “generation” and “age,” which have no equivalents in most languages of the world. By contrast, the seven building-blocks of kinship and social cognition recognized in the NSM theory – “mother,” “father,” “wife,” “husband,” “men,” “women” and “children” – are, evidence suggests, lexical universals, experience-near and empirically verifiable. If in our portrayal of local systems of kinship we rely on such universals (as it is done in NSM-based analyses), we can capture generalizations about the structure of such systems by recognizing recurrent semantic components

Table 1 (Wierzbicka). *Universal semantic primes (English exponents), grouped into related categories*

I, YOU, SOMEONE, SOMETHING ~ THING, PEOPLE, BODY	substantives
KIND, PART	relational substantives
THIS, THE SAME, OTHER ~ ELSE	determiners
ONE, TWO, SOME, ALL, MUCH ~ MANY, LITTLE/FEW	quantifiers
GOOD, BAD	evaluators
BIG, SMALL	descriptors
KNOW, THINK, WANT, FEEL, SEE, HEAR	mental predicates
SAY, WORDS, TRUE	speech
DO, HAPPEN, MOVE, TOUCH	actions, events, movement, contact
BE (SOMEWHERE), THERE IS, HAVE, BE (SOMEONE/SOMETHING)	location, existence, possession, specification
LIVE, DIE	life and death
WHEN ~ TIME, NOW, BEFORE, AFTER, A LONG TIME, A SHORT TIME, FOR SOME TIME, MOMENT	time
WHERE ~ PLACE, HERE, ABOVE, BELOW, FAR, NEAR, SIDE, INSIDE	space
NOT, MAYBE, CAN, BECAUSE, IF	logical concepts
VERY, MORE	intensifier, augmentor
LIKE ~ WAY	similarity

*Note.* Primes exist as the meanings of lexical units (not at the level of lexemes). Exponents of primes may be words, bound morphemes, or phrasemes. They can be formally complex. They can have combinatorial variants or “allolexes” (indicated with ~). Each prime has well-specified syntactic (combinatorial) properties.

and recurrent kin name extensions both with and across languages and cultures. Why not start building bridges between cognitive anthropology and evolutionary psychology on these empirical, culture-neutral, and theory-independent human universals?

## Author’s Response

### Thinking about kinship and thinking

doi:10.1017/S0140525X1000275X

Doug Jones

*Department of Anthropology, University of Utah, Salt Lake City, UT 84112.*  
douglas.jones@anthro.utah.edu

**Abstract:** The target article proposes a theory uniting the anthropological study of kin terminology with recent developments in linguistics and cognitive science. The response to comments reaches two broad conclusions. First, the theory may be relevant to several current areas of research, including (a) the nature and scope of the regular, “grammatical” side of language, (b) the organization of different domains of conceptual structure, including parallels across domains, their taxonomic distribution and implications for evolution, and (c) the influence of conceptual structure on social structure. Second, the theory compares favorably with alternatives, including (a) the theory that kin terminology is not really that complicated, (b) the theory that kin terms mirror social categories, (c) componential analysis, and (d) kinship algebra. If further research in anthropology, linguistics, and other fields supports the theory, and confirms the psychological reality of proposed mechanisms, then kinship may emerge as a model system for the study of important issues in cognition and social organization.

The target article sets forth a theory – call it the Conceptual Structure and Grammar (CS&G) theory – of kin terminology. In presenting the theory, I find myself in the position of a matchmaker, trying to broker a marriage

settlement between the anthropology of kinship and current work in linguistics and cognitive science. In responding to commentators’ appraisals of the proposed match, I first say more about how the two sides might live together, then take up objections to the match from supporters of rival theories of kin terminology, and finally say something about the theory’s prospects.

The first section of the response is concerned with how the CS&G theory situates the study of kin terms and kinship rules within several current research programs in the cognitive sciences. This section addresses comments about the relationship of kinship grammar to grammar more generally, as understood within the framework of Optimality Theory. It also discusses comments relating the conceptual structure of kinship to other domains of conceptual structure, especially the structure of physical space, and relating human and nonhuman conceptual structure. Finally, this section takes up a topic raised by a number of commentators, the relationship of kin categorization to kinship and social organization more broadly, positioning the current theory within a larger program of investigating how conceptual structure affects social structure. According to **Levinson**, “The neglect of kinship in current anthropology and in the cognitive sciences is not far short of a scandal”: In this section I try to show that the cognitive sciences have much to gain from ending this neglect.

The second section responds to criticisms and claims from defenders of alternative approaches. Some commentators argue that the present theory is too complicated and could be replaced by a simpler, more intuitive approach. Others favor sociocultural rather than cognitive-linguistic accounts of kin categorization. And others advocate alternative formal theories: componential analysis and kinship algebra. This section addresses these comments, while expanding on the treatment of Seneca terminology presented in the target article, and bringing in other terminologies. Throughout, I try to show that specific criticisms of the CS&G theory don’t hold up, and that the theory has advantages over the alternatives.

A concluding section considers what directions the theory might take in the future.

## R1. Conceptual structure and grammar, meet kinship

A number of commentators respond to a major thesis of the target article: that kinship, and kin terminology specifically, is tightly structured, even “grammatical,” and the study of kinship has multiple connections with ongoing research programs in linguistics and other highly structured domains of cognition and interaction. Some of these connections are reviewed below.

### R1.1. Kinship grammar as grammar

The present theory may have implications for the nature and scope of grammar. The distinction between grammar – the rule-governed, generative part of language – and the lexicon – the arbitrary, memorized part – is commonly equated with the distinction between syntax and words-plus-morphemes. (Leaf, for example, seems to equate these as a matter of definition.) But even if we somehow ignore phonological grammar, these two distinctions don’t really line up very well. Many items in the lexicon are bigger than words, including idioms like “kick the bucket,” and syntactically anomalous constructions like “the \_\_\_ [comparative phrase], the \_\_\_ [comparative phrase]” (e.g., “the more, the merrier”; Jackendoff 2002, pp. 167–82).

Conversely, the evidence from kin terminology implies that, in some semantic fields, words behave like pieces of grammar. More precisely, kin terminologies (the way kin types are split and merged), rather than kin terms (the actual words used for kin), are grammatically structured. Like the inflections of frequently used regular verbs, kin term meanings may be memorized but are apparently also subject to an OT-style process of evaluation often enough to keep them grammatical. Hogeweg, Legendre, & Smolensky (Hogeweg et al.) present their own version of the distinction between kin terminology and kin terms. They also clarify the difference between (1) theories of how the contribution of words to meaning varies with context, and (2) the present theory of how the context-independent meanings of kin categories are structured.

The CS&G theory is just one example of the very wide range of application of OT. In his comment, Biró asks, “Will Optimality Theory colonize all of higher cognition?” The target article suggests an answer: OT-style grammar can colonize only “grammar-friendly” domains of language, domains that support a successful process of constraint discovery. In constraint discovery, language learners explore their motor, perceptual, and conceptual capacities to discover universal prototypical and distinctive features. Since others in the community are doing the same, learners can count on constraints being mutually known and can move on to using linguistic evidence to determine how constraints are ranked. Different linguistic environments may differ in how thoroughly they encourage learners to explore different regions of constraint space, but in any region they explore, learners are expected to discover (not copy) much the same constraints. For example, most languages don’t encourage

their learners to explore the constraint space for sign-language phonology, but in those that do, learners seem to end up finding the same constraints (Brentari 1998). Contra Bloch and Hudson, then, theories of constraint discovery have more substance than the banal observation that learning plays a role in constraint acquisition; they require that constraints be grounded in precultural universals.

Another take on these issues comes from Miers and Nevins. Miers outlines a version of Optimality Theory applied to kin terminology that departs substantially from the standard version in its treatment of faithfulness and markedness. This work might have a place within the framework outlined by Nevins, who discusses a range of theories in phonology that may deliver some of the same results as OT without using OT. Following the hypothesis of *Cross-Modular Structural Parallelism*, Nevins suggests that phonology and kin terminology may represent the same linguistic architecture operating on two different “alphabets.” If this proposal can be made to work, it may offer a new approach to delimiting the potential scope of grammar. Clearly this is a large topic that deserves more attention than I give it here.

### R1.2. Kinship space and other conceptual spaces

Because different domains of conceptual structure represent very different sorts of content, we might expect them to be organized very differently. However, according to the target article, the conceptual structure of kinship borrows much of its organization from the conceptual structure of space. This result is consistent with other research finding parallel organization across semantic fields. Together with evidence regarding conceptual structure in nonhuman primates, this may have implications for the evolution of cognition; I discuss several relevant responses below.

Bennardo’s work considerably advances our understanding of the extension of spatial thinking to more abstract domains (and counters the skepticism on this score of El Guindi and McConvell). He demonstrates a relationship between universals of spatial cognition and universals of kinship cognition. But he goes further, finding systematic covariation between cultures of space and kinship: A culture that prefers one frame of reference over another for representing space is likely to make a parallel choice in representing kinship. This work goes beyond the target article in demonstrating the integration of culture across cognitive domains.

Seyfarth & Cheney (see also Cheney & Seyfarth 2007) review evidence that many nonhuman primates not only recognize their kin, but also have abstract representations of social categories that facilitate social inference. They note that some of these representations, and the vocalizations associated with them, may be categorical rather than metric, digital rather than analog. Their observations imply that the organizing principles of human kin terminology – sex, kinship distance and grade (rank), and group membership – are probably primitives of social cognition in nonhuman primates and other social mammals and birds. Thoughts about kinship and other social relationships may be the first abstract thoughts that any animal had.

What are the roots of social cognition? Cross-domain parallels in the organization of conceptual structure might reflect the human gift for metaphorical thinking, but the evidence for abstract thinking about social

relationships in nonhuman primates suggests an evolutionary scenario. The mental organs adapted to representing space seem to have been exapted to represent more abstract relationships, starting with kinship and social organization. Modeling kin relationships as relationships in an abstract kinship space would have some immediate payoffs, allowing inferences like: “If A is above B and B is above C, then A is above C,” and so on. This scenario implies that homology as well as adaptation has played a role in the evolution of the mind. The conceptual structure of kinship may be adapted for doing genealogy and solving social problems on Pleistocene savannahs, but it may also owe some of its organization to a more ancient history.

### **R1.3. Kinship, from conceptual structure to social structure**

Conceptual structure is likely used not only in communication, but in cognition and social interaction more generally. In the target article, the focus was on kin terminology, which gives a particularly clear view of the conceptual structure of kinship. However, as a number of commentators remark (or complain), there is more to human kinship than kin terms (**Bloch, Gerkey & Cronk, Knight, Levinson**). This section responds to these comments by briefly sketching the broader relevance of the CS&G theory to social coordination and social structure. The discussion covers some of the games people play involving their kin and how conceptual structure may influence the outcomes of these games. This may be part of a larger story, of how universal conceptual primitives facilitate convergence on shared moral norms in a number of social domains.

Marriage, in particular deciding who may marry whom, is one social arena in which human beings often find themselves playing coordination games. An accepted set of rules, even if partly arbitrary, that divide each person's relations into marriageable and unmarriageable on the basis of kinship can regulate sexual competition and foster suprafamilial alliances.

Another family of coordination games involving kin may involve what I have labeled *group nepotism* (Jones 2000; 2004). Altruism toward kin is a public good. Natural selection favors higher levels of kin altruism if people coordinate their assistance than if each acts separately. When two brothers, for example, must choose how much help to give a needy third brother, their effective coefficient of relatedness when they act independently is the standard Hamiltonian 1/2; when they act together it ranges up to 7/10. (The mathematics involved is covered in Jones [2000] as “The Brothers Karamazov Game.”) Especially in large groups of distant kin, the evolutionarily expected level of altruism toward the needy is much higher if groups can impose enforceable public commitments on their members. This may be relevant to the distribution of gains from collective action in large descent-based groups like the Lamalera whale hunting parties (Alvard 2003) cited by **Gerkey & Cronk**, and more generally to the establishment of norms of generalized (rather than balanced) reciprocity among kin.

The norms that govern marriage and socially imposed altruism toward kin have some of the same structure as the rules that govern kin terminology. Both terms and norms are sensitive to genealogical distance, but allow

other principles to orient and reshape kinship space. Kin terminologies often treat parallel or unilineal relations as closer than cross or non-unilineal; marriage rules often use the same distinctions to divide kin into those too close to marry and those preferred or prescribed as spouses. Kin terminologies sometimes move affines into the consanguine category – for example, treating a sister-in-law as a kind of sister; marriage rules sometimes follow suit, extending incest taboos to affines (Héritier 2002). Kin terminologies may treat certain classes of sibling as equivalent – for example, equating a woman's son and her sister's son; norms of sharing may be built around the ideal (often evaded in practice, of course) of the unity of the sibling group. More generally, both terms and norms impose categorical distinctions on a continuously varying world. “[K]inship systems have a digital character” (**Levinson**) and “a formal kinship system is designed to minimize scope for disputation: It does this by eliminating shades of grey” (**Knight**).

The parallels between kin terminology and social organization are a familiar topic in social anthropology. They are commonly assumed to result from the influence of each culture's social structure on its terminology (see sect. R2.2). But I suggest there is something more going on: Norms and terms have some of the same structure because they draw on the same conceptual building blocks. Both of these causal pathways are discernible in Figure 1 in the target article. The first pathway starts from “local organization” and follows the arrows along the bottom row to “kin terminology.” The second starts from “primitives of conceptual structure” and follows the arrows either to “local organization” or to “kin terminology.”

The dependence of both moral codes and semantic grammar on universal conceptual primitives may be a general phenomenon, applying to more than kinship (Pinker 2007, pp. 228–33). For example, in making judgments about the morality of causing and avoiding harm, people normally do not rely on the maxim of the greatest good for the greatest number, but turn instead to intuitions deriving from the conceptual structure of causation and agency (Mikhail 2007; see **Wierzbicka** for the corresponding conceptual primitives: *because*, *do*, and *happen*).

The hypothesis, then, is that the CS&G theory is relevant to the social organization of kinship because the ingredients of conceptual structure go into the making of social structure. The outcomes of coordination games depend not just on material factors, but on the mutual knowledge that players bring to the table, including knowledge deriving from precultural universals of cognition. This hypothesis, although rooted in an evolutionary perspective on human behavior, departs from theories in human behavioral ecology in which social organization is the unintended by-product of individual strategizing among inclusive-fitness-maximizers – monads with gonads. Representations of the social order – not just as it is, but as it should be – play a role in making society.

### **R2. Kinship, meet conceptual structure and grammar**

The previous section reviewed the potential relevance of kinship to several research programs in the cognitive sciences. This section considers the other side of the



exchange: the relevance of recent work in linguistics and cognitive sciences to kin terminology. The section offers a defense in detail of the CS&G theory against a range of criticism, especially from advocates of rival theories.

Some of **Kronenfeld's** remarks serve to frame the discussion here. He notes that the target article considers only a portion of English and Seneca terminology, and he asks what the present theory buys us that we don't get from other approaches. This section addresses both these issues. In reply to several commentators who raise questions about the mechanics of the theory, I expand the discussion of the Seneca case, and also show how the proposed constraints apply to some of the Chinese data presented by **Liu, Ge, Mai, & Luo** (Liu et. al.) I hope this part of the reply offers some assurance that the present theory can handle not just hand-picked examples, but challenges raised by sharp critics, and additional data. Some commentators defend alternative approaches, including sociocultural explanations of kin terminology, componential analysis, and kinship algebra. I offer some comments on these, and indicate what seem to be the advantages of the present theory.

This section is necessarily somewhat technical. Readers unfamiliar with the details of kin terminology might choose to skim in particular sections R2.2 (especially the middle) and R2.3.

### **R2.1. Is the theory too complicated?**

**Behme, Hudson,** and **Wierzbicka** argue that the CS&G theory is too complicated and unintuitive. Hudson starts off by proposing the "easier explanation" that the structure of kin terminologies is overtly represented in native speakers' terms. (See Coult 1966 for an early version of this.) Hudson argues that, for example, the availability of the inclusive term *parent* in English allows the construction of further categories like *aunt* (*parent's sister*) and *grandfather* (*parent's father*). But then he takes it back. As he observes, the concept Sibling seems to be involved in defining *cousin* (Parent's Sibling's Child), even though the word *sibling* is used infrequently or not at all by many English speakers. (In my anthropology classes, students usually define *cousin* disjunctively, as something like *aunt's or uncle's child*.) Examples like this, rather than an unnatural love of complexity for its own sake, have led anthropologists to postulate extra levels of representation beyond what is overtly expressed. Thus the advocates of componential analysis propose distinctive features as an underlying level of representation of kin terms, while the practitioners of kinship algebra distinguish the abstract structure of kin categories from the actual terminology, with the latter derived from the former by adding sex distinctions and/or cross-sex equations.

**Wierzbicka** proposes that kin terms specific to one language can be defined based on a few core kin terms lexicalized more-or-less universally, "father," "mother," "husband," and "wife." This proposal is part of a larger program of assembling a collection of universal semantic primitives that can serve as building blocks for defining culture-specific words and concepts.

I have no quarrel with the specific primitives on **Wierzbicka's** carefully crafted list. However, the principle that we explain the natives' use of language using only translations of terms shared by the natives with everyone else

runs into problems when we turn from the lexicon to grammar. For example, the difference in verb argument structure between "She rolled the ball" and "The ball rolled" turns on universally lexicalized concepts from Wierzbicka's list, such as *because*, *do*, and *happen*. But to explain in detail which micro-classes of verbs take what constructions, and how this varies across languages, it is necessary to look "under the hood" at the internal structure of these concepts. This level of representation is not so evident in the lexicon, nor so readily accessible to the consciousness of native speakers (Pinker 2007, pp. 65–73; see Legendre et al., 2006, for an OT treatment of verb micro-classes across languages.) The same applies to kin terms. We need to know something about the feature structure or other relational properties of kin types to explain why "mother and father" is a natural class but "mother and husband" is not.

In short, kin terminology is not simple. Like other areas of grammar, it involves nonovert representations. It's not clear what the metric for complexity is, but the CS&G theory is not notably more complex than any well-developed alternative. If anything, the theory has the advantage of borrowing some of its complexity from other domains of language and cognition. The machinery of Optimality Theory, and maybe even the local version of optimization supported here, is imported from outside the domain of kinship, while the conceptual structure of kinship takes some of its organization from the conceptual structure of space.

### **R2.2. Does kin terminology derive from social organization?**

Variation in kin terminology is correlated with variation in social organization. For example, bifurcate merging aunt and uncle terms are more common in societies with matrilineal and/or patrilineal descent groups or other social categories (Murdock 1949, pp. 156, 164–166, 180–183; Whiting et al. 1988). (Bifurcate merging aunt terms means one word for Mother and Mother's Sister, another word for Father's Sister; bifurcate merging uncle terms means one word for Father and Father's Brother, another word for Mother's Brother.) The Seneca, with bifurcate merging terminology and matrilineal descent groups, fit this generalization.

Correlations between kin terminology and social organization and culture have led some anthropologists to argue that sociocultural explanations can supersede cognitive-linguistic ones in accounting for what is systematic in kin terminology. **Hudson, Behme, Leaf,** and perhaps **Levinson** support social structural explanations of kin terminology. **El Guindi** argues for understanding kinship as holistically "embedded in cultural knowledge," effectively denying the content/structure distinction proposed in the target article. **Jordan & Dunn** argue that a historical approach to kin terminology "immediately reduces the amount of variation that needs to be accounted for by the OT framework."

The real question is whether arguments of this kind can be cashed out in the form of hypotheses linking social categories and statuses to terminology in detail. The record of past attempts is not encouraging. A number of anthropologists have proposed explanations of kin terms along the lines of "'K' means 'woman of my mother's patrilan,'" or "'L' means 'resident male of my father's hamlet,'" but

these typically have been shown not to predict the assignment of kin terms very accurately (Gould 2000, pp. 371–78; Lounsbury 1965). Seneca cousin terms provide a case in point: They are quite regular, but, as **Kronenfeld**, **McConvell**, and **Salazar** note, the division they establish between classificatory siblings and cross cousins doesn't map cleanly onto any social-structural divide. On present evidence, the effect of social organization on kin terminology is mostly loose and indirect, filtered through cognitive-linguistic principles.

Ideally, then, a theory of kin terminology should be consistent with two findings: first, kin terminology correlates with social organization; second, there is no one-to-one mapping between kin terms and social categories. The CS&G theory accounts for both findings by positing an indirect connection between social structure and kin terminology. Local social organization, acting probabilistically and with some time lag, influences the local ranking of universal kin term constraints. This ranking in turn generates kin terminologies through constraint interaction governed by principles of Optimality Theory. This is shown in Figure 1 in the target article, where a series of arrows runs along the bottom row from “local organization” to “kin terminology.”

The rest of this subsection reviews a specific case, the relationship between matrilineal descent and cousin terminology in Seneca, comparing several alternative approaches (**Leaf**, **McConvell**, **Salazar**) and taking a side trip through Chinese cousin terms (**Liu et al.**) to show the strength and flexibility of the present theory. The last two paragraphs summarize the argument.

According to **Leaf**, “Seneca terminology embodies Seneca social conceptions just as English terminology embodies English social conceptions.” He writes that Seneca cousin terms “form groups based on a specific contrast between own matrilineal clan as against all other clans. . . . Own brothers and sisters are grouped with mother's sister's children and contrasted with all other relations on one's own generation. Children of *ha-nih* (father and father's brother) who are also children of own mother are in own sibling group, children of other *ha-nih* are in the all others group.”

But **Leaf's** account of Seneca terminology is wrong. Morgan, whom **Leaf** cites, is quite clear that the Seneca contrast is not between mother's sister's children and all other cousins, but between cousins linked through same-sex parents and cousins linked through opposite-sex parents (Morgan 1997[1871], pp. 156–157, 160–161, 162, Plates VI, VIII) – not matrilineal versus nonmatrilineal cousins, in other words, but parallel versus cross. The belief that social organization is directly reflected in kin terminology seems to have led **Leaf** to misread the evidence.

**McConvell** and **Salazar** approach the same topic from the other end. Both note the ubiquity of parallel/cross distinctions in kin terminologies and propose that the relevant distinction is the sexually symmetrical one between links through same-sex and opposite-sex siblings. **McConvell** suggests this could be handled by a DISTINGUISH PARALLEL/CROSS constraint. Applied to the Seneca case, this would achieve descriptive adequacy at the cost of severing the connection between kin terminology and social organization. The two commentators take this course because, although sympathetic to the use of Optimality Theory,

they are skeptical about one of the constraints in the target article, DISTINGUISH MATRIKIN. This constraint requires that kin in Ego's matriline (stippled in Fig. 2) be distinguished from kin in the adjacent matriline of Mother's Brother's Child (vertical stripes) and Father, Father's Sister, and Father's Sister's Child (horizontal stripes).

There are two issues at stake here. One involves the placement of the boundary between adjacent matrikin. It may be possible to redraw this boundary to make more room for the parallel/cross-sibling distinction **McConvell** and **Salazar** emphasize.<sup>1</sup> But this revision, whatever its merits, is of little consequence in the present case. The more relevant issue is that **McConvell** and **Salazar** treat parallel versus cross as a single, sexually symmetrical distinction. But DISTINGUISH MATRIKIN is asymmetric with respect to sex – it registers distinctions based on different maternal links, not different paternal links, consistent with Seneca matrilineality.

Clearly some discussion is needed of how a sexually asymmetric constraint can generate the sexually symmetric terminology of Seneca. The rest of this subsection supplies this discussion, showing how DISTINGUISH MATRIKIN interacts with other constraints to generate a sexually symmetrical cousin terminology in the case of Seneca, while its patrilineal counterpart, DISTINGUISH PATRIKIN, interacts with a differently ranked set of constraints to generate the sexually skewed Chinese cousin terminology. This discussion, rather than uncovering a fatal flaw in DISTINGUISH MATRIKIN, as **McConvell** and **Salazar** suppose, ends up showcasing a major strength of Optimality Theory: one constraint can produce a variety of effects, depending on how it interacts with others.

To show how the present theory generates different cousin terminologies, we start with the following abbreviated version of the Seneca ranking, DISTINGUISH MATRIKIN » DISTINGUISH SEX » MINIMIZE PARENTS' SIBLINGS. (We ignore relative age here.) We can follow the process in slow motion if we stick to replacing just adjoining pairs of elements at each move. With the two parallel cousin types, Mother's Sister's Child and Father's Brother's Child, the first move is to replace Mother's Sister with Mother (same matriline, same sex), and Father's Brother with Father (same matriline, same sex), generating Mother's Child and Father's Child respectively. These replacements obey the injunction to MINIMIZE PARENTS' SIBLINGS – including embedded Parent's Sibling – and don't violate higher ranking constraints. These outputs become inputs on the next round. Because Father's Child does not belong to Father's matrikin and so is not adjacent to Mother's matrikin, it can be merged with Mother's Child, as some type of sibling.

On the other hand, the high-ranking DISTINGUISH MATRIKIN bars mergers of the two cross cousin types, Mother's Brother's Child and Father's Sister's Child with Parent's Child.<sup>2</sup> The best the lower-ranking MINIMIZE PARENTS' SIBLINGS can do is to insist that these two types be combined into a single cross cousin term. Thus DISTINGUISH MATRIKIN, interacting with other constraints, can generate a standard parallel/cross distinction.

But in other contexts, DISTINGUISH MATRIKIN and DISTINGUISH PATRIKIN produce different effects. Chinese cousin terms, presented by **Liu et al.**, offer a

serendipitous opportunity to show that the present constraints work well across a wider range of terminologies, an important desideratum in OT. In Chinese terminology, a father's brother's children are separate both from siblings and from other cousins. Other cousins are lumped together, not distinguished as parallel or cross. In other words, Chinese terms skew patrilineally.

The patrilineally skewed constraint, DISTINGUISH PATRIKIN, can generate the basic pattern of Chinese cousin terms as part of the ranking DISTINGUISH PATRIKIN » DISTINGUISH DISTANCE » MINIMIZE PARENTS' SIBLING'S \_\_\_\_ » DISTINGUISH SEX. (We ignore sex and relative age of cousins here, and some obvious morphology.) There are two crucial differences here from the Seneca ranking. First, Chinese assigns high rank to a constraint attuned to patrilineal rather than matrilineal distinctions, reflecting the patrilineal character of traditional Chinese society. Second, the constraint DISTINGUISH DISTANCE ranks high, and prevents parents' siblings and embedded parents' siblings from being merged with parents and embedded parents. The distance constraint prevents Mother's Sister's Child from being equated with Mother's Child, thus blocking the parallel cousin/sibling equations seen in Seneca. In this context, MINIMIZE PARENTS' SIBLING'S \_\_\_\_, in interaction with lower-ranking constraints, enforces a merger of nonpatrilineal cousins, rather than cross cousins.<sup>3</sup>

In summary, the asymmetrical constraints DISTINGUISH MATRIKIN and DISTINGUISH PATRIKIN can generate either symmetrical parallel/cross distinctions like those in Seneca, or asymmetrical distinctions like those in Chinese, depending on how they interact with other constraints. At least for now, it seems that the two skewed constraints are necessary, but an additional unskewed parallel/cross constraint is superfluous.

In the end, the criticisms of Leaf and of McConvell and Salazar complement each other. Leaf presumes a direct connection between Seneca matrilineality and Seneca terminology, and gets the facts about the latter wrong. McConvell and Salazar argue that the parallel/cross distinctions observed in Seneca and other terminologies reflect the operation of one or more underlying parallel/cross principles, and leave Seneca terminology divorced from Seneca social organization. In spite of their different conclusions, these commentators share the assumption that the principles governing kin terminologies should be visible on the surface. By contrast, the present theory, which distinguishes between underlying constraints and the surface distinctions generated by constraint interaction, has more room to accommodate systematic but indirect connections between social structure and kin terminology.

### R2.3. Componential analysis

Componential analysis treats kin terms as bundles of distinctive features; the theory lacks separate machinery for handling markedness and kin term extensions. Kay defends "li'l ol' componential analysis" as an alternative to the CS&G theory, which he claims cannot handle Seneca descending generation terms or extended cousin terms. This subsection corrects several mistakes in Kay's comment, shows how the CS&G theory deals with some special characteristics of Seneca kin terms, and compares

componential analysis and other approaches to distant kin terms.

Kay claims that the proposed constraint DISTINGUISH MATRIKIN can't handle Seneca terminology for children and siblings' children. These include sex-of-Ego distinctions with female and male speakers using different terms for their kin. The pattern to be explained goes as follows: the Seneca term for 'daughter' is also used for Woman's Sister's Daughter and Man's Brother's Daughter. The term for 'son' is also used for Woman's Sister's Son and Man's Brother's Son. Four additional terms cover Woman's Brother's Daughter, Woman's Brother's Son, Man's Sister's Daughter and Man's Sister's Son. According to Kay, "Here the OT analysis fails. Ego's sister's child is a member of Ego's matriline regardless of Ego's sex." However, the second sentence is true, but irrelevant to the issue at hand. What matters is Ego's *children's* matriline (not Ego's matriline, as Kay has it), because some of Ego's sibling's children, and not others, are classified with Ego's *children* (not with Ego) as 'daughter' and 'son.' Whether Ego's children belong to Ego's sister's matriline depends on the sex of Ego: "yes" if Ego is female, "no" if Ego is male. DISTINGUISH MATRIKIN gets this right.

The machinery for handling a terminology of this sort was discussed in Jones (2003b). It can be used to account for markedness relationships involving sex-of-Ego distinctions. We begin with a notation for inverse kin terms: if X is K to Y, then Y is  $K^{-1}$  to X. If John is uncle to Dylan, then Dylan is uncle<sup>-1</sup> (i.e., Man's Sibling's Child) to John (ignoring uncles by marriage; see also Gould 2000, p. 28). In this notation, the six Seneca terms above are female and male versions of Child, (Father's Sister)<sup>-1</sup>, and (Mother's Brother)<sup>-1</sup>. This notation shows that Seneca does not distinguish nieces and nephews from aunts and uncles as clearly as English does. This is evident not only in the distribution of terms but in their morphology. The Seneca term for my mother's brother is roughly 'he-uncle-me,' while the terms for the inverse, my sister's daughter/son (man speaking), are built from the same root and are roughly 'I-uncle-her/him' (Kay 1975). The inverseness of Seneca descending generation terms is there in plain sight.

The target article presented a DISTINGUISH GRADE constraint. The constraint keeps ascending and descending generations separate, and older and younger kin within a generation. In doing so, it prevents a kin type from being equated with its inverse. But Seneca presents an in-between case, in which some descending generation terms are neither completely distinct nor completely separate from the corresponding ascending generation terms. We can handle this by breaking DISTINGUISH GRADE into two constraints, one of which is more lax about enforcing hierarchical distinctions. Consider the following constraint ranking:

DISTINGUISH GENERATIONS & DISTANCE  
 DISTINGUISH MATRIKIN  
 MINIMIZE COUSINS  
 DISTINGUISH GRADE (LAX)  
 DISTINGUISH SEX  
 MINIMIZE SIBLINGS' CHILDREN  
 MINIMIZE PARENTS' SIBLINGS  
 MINIMIZE SIBLINGS  
 DISTINGUISH GRADE (STRICT)

MINIMIZE CHILDREN  
DISTINGUISH DISTANCE

This repeats the constraint ranking for Seneca from the target article, with several changes: (1) DISTINGUISH GRADE comes in a lax version, which allows partial equations of inverses, and a strict one, which doesn't, (2) two markedness constraints have been added for the first descending generation, and (3) DISTINGUISH GENERATIONS has been tweaked to allow mergers in equidistant generations (see Note 2 in target article).

The new constraint ranking handles the special features of Seneca terms for descending generations (and younger siblings) without much extra machinery. Changing the ranking can generate distinctions found in other languages. For example, moving MINIMIZE CHILDREN up one place would produce a terminology with distinctions between Father<sup>-1</sup> (Man's Child) and Mother<sup>-1</sup> (Woman's Child). And the same trick of breaking up faithfulness constraints into graded lax and strict versions can handle other sorts of morphological variation, like whether Seneca sex distinctions are carried by roots or affixes, or how English *-in-law*, *grand-*, and *great-* affixes work (a topic raised by **Leaf**).

**Kay** also rejects the proposed analysis of Seneca cousin term extension by one-adjoining-pair-at-a-time replacement. "[N]o such set of local rules can account for the Seneca cross/parallel facts." This is wrong. Take the kin type that he gives, the fourth cousin "father's mother's father's mother's brother's daughter's son's son's child." Note that in many cultures, nobody starts with such an elaborate formula when reckoning kin terms; they would begin with "My father's 'cross cousin' is father to that person" (**Levinson, Read**). In other words, Kay's formula is to kin terminology what one of Proust's long sentences is to syntax: a possible case that one would be unlikely to encounter in everyday life. Nonetheless, a set of one-adjoining-pair-at-a-time replacement rules following the constraint ranking in section 3.1 in the target article gives the right answer, with no need to "imagine rewrite rules that look...at nonadjacent nodes."<sup>4</sup>

**Kay** claims that "componential analysis, gets the whole job done...with less machinery." This is not quite right. Componential analysis gets the job done in fewer steps (in a highly artificial example), but at the cost of more machinery, in the form of a special Iroquois-cross distinctive feature. This is problematic, regardless of whether we use componential analysis or Optimality Theory. There are a variety of ways of extending terms to more distant kin (Godelier et al. 1998): Does each of these call for a new distinctive feature or a new constraint?<sup>2</sup>

Perhaps rules for distant kin term extensions are open-ended and transmitted through explicit instruction, more like rules for games or poetic forms than rules of grammar. In this case, there would be no theoretical problem with multiplying distinctions indefinitely. Or perhaps humans have specialized adaptations for classifying kin all the way out to second cousins. This is **Miers'** position, if I have understood him correctly.

But there is a more parsimonious possibility: Distinctions may emerge through the interaction of a limited set of constraints according to rules of local optimization. To explore this further, let us return to the second-cousin formula Mother's Mother's Brother's Son's Son.

In Seneca, the categorization of this relative as a cross cousin rather than some kind of sibling depends only on the sexes of the two linking relatives in the parental generation. The sex of the two linking relatives in the grandparental generation is irrelevant. In other terminologies, the opposite is true: A cross-sex connection in the grandparental generation determines the classification regardless of the sexes in the parental generation. And in so-called Dravidian terminologies, sexes in both parental and grandparental generations make a difference to the outcome. This looks like a markedness/faithfulness trade-off between neutralizing linking-sex distinctions in one generation or the other, and accounting carefully for both generations, in the course of local optimization. In other words, it looks like a good fit for the machinery developed in the target article. At this stage, we cannot be sure this is the right approach, but it seems worth exploring.<sup>5</sup>

One final note on distinctive features: while componential analysis probably doesn't work as a complete theory, it can generate some common patterns on its own. For example, we can get from bifurcate merging aunts (Father's Sister ≠ Mother's Sister = Mother) to bifurcate collateral (Father's Sister ≠ Mother's Sister ≠ Mother) by activating a distance (or lineal/collateral) distinction. **Musgrave & Dowe**, however, think this has to do with differential markedness: that in the first case, but not the second, cross-kin are marked relative to parallel. On the standard definition of markedness (Jones 2004) this is wrong. The reason the distance distinction doesn't split Father's Sister in the second case is that there's no distance inside Father's Sister to split, not because the type is marked. For an example that does involve differential markedness, see the relative age distinctions among Chinese uncles in **Liu et al.**'s comment, which are activated for the unmarked but not the marked type.

#### R2.4. Kinship algebra

**Read** lays out the basics of kinship algebra, an alternative approach to kin terminology. He argues for a strict separation between (1) kin terminologies as formal systems to be studied in the framework of abstract algebra, without reference to genealogy, and (2) rules mapping kin terminologies onto genealogy. **Lyon** also cautions that "kinship terminologies can be produced without reference to any notion or instance of genealogical relatedness." I respond with a parable.

Once upon a time, Professor P developed a formal theory of the shape of pants, called pants geometry. Pants geometry borrowed from topology and other branches of mathematics, taking into account, for example, that pants are highly symmetrical from right to left, but not from top to bottom. With a modest set of parameters, the theory claimed to account for the shapes of everything from bell-bottoms to lederhosen to skorts. With this theory in hand, Professor P announced that pants could be defined in purely geometric terms without reference to the human form. He also reminded his readers that many pants, including most of those given as birthday presents, are never worn. He declared that the old anthropomorphic definition of pants as a garment worn on the lower body and covering the legs separately had at last been overturned, and deplored the sloppy habit of referring to pants "legs."

Of course Professor P's victory over anthropomorphism in the field of pants studies was illusory. It's not just a coincidence that pants and people have legs and seats, that men's pants generally have flies and men have . . . , etc. Similarly, it is not a necessary truth, but an empirical finding in need of theoretical explanation, that every society has a system of terms systematically related to one another in such a way that they can be mapped onto genealogical positions, and that the natives themselves can do this mapping – even if those terms are used for nongenealogical purposes as well.

I suggest that a contrast proposed by Sperber (1996, pp. 134–46) is useful here, between the evolved (or proper) domain of an adaptation, and its cultural domain (see also Sperber & Hirschfeld 2004). For example, humans in all likelihood have evolved machinery for assessing the mental states of others (the evolved domain of “theory of mind”), but they also employ this machinery in culturally specific ways in attributing mental states to ghosts, oracles, storms, and agents of disease (the cultural domain of theory of mind). Perhaps the way to break out of the seemingly endless argument about what kinship terms “really” mean is to ask instead about the evolved and cultural domains of kin categorization. From this perspective, **Read's** achievement is an exceptionally rigorous characterization of the machinery for tracking genealogy (and maybe for doing other things; see sect. R1.3).

There are more down-to-earth differences between kinship algebra and the current approach. Part of what characterizes kin terminologies, according to kinship algebra, are structural equations. Some of these are universal, defining the very domain of kinship (e.g., Sibling of Sibling = Sibling), others are found in some terminologies but not others (e.g., the English rule Spouse of Sibling = Sibling of Spouse). These equations have consequences that ramify through kinship systems and give them much of their structure. But there is the same problem with structural equations as with replacement rules: it's not clear within the theory what limits there are on allowed equations.

### R2.5. Comparing theories

By way of a summary, let's return to **Kronenfeld's** question: What does the present theory buy us that we don't get from other approaches? Some of the alternative theories imply that kin terminology is psychologically simple, perhaps because its complexities derive from the social system rather than the mind. But these theories seem to have trouble accounting for kin terminology in detail. The other alternatives, which allow for autonomous cognitive-linguistic processes, have different strengths and weaknesses. Componential analysis has identified a set of distinctive features, comparable to those in phonology, that help to define the natural classes into which kin types are organized. Yet markedness effects are generally left out, and descriptive adequacy achieved only at the cost of multiplying contrived, undermotivated features. Derivational approaches, including reduction rules and kinship algebra, are successful in showing how rules for extending kinship terms out from a small core can account for patterns of variation in particular cases, but leave unanswered questions about what replacement rules or structural equations are allowed. As **Levinson**

writes, “[p]revious approaches, such as componential analysis and reduction rule analysis. . . have each captured part of the phenomenon but somehow have failed to give us an exhaustive way to think about the typology of kinship systems.”

Ideally we would like to get the best of each of these approaches in one package. In a package deal, for example, we might find that the range of possible replacement rules is somehow constrained by the need to respect distinctive features. This deal, I claim, is what the present theory offers, by including distinctive features and markedness effects in a unified framework, and handling derivations by stepwise optimization. That the deal also includes a new take on the relationship between social structure and kin terminology, and on the conceptual structure of kinship, makes it even more of a bargain.

### R3. Prospects

Suppose, as the preceding section argues, that no insuperable impediments stand in the way of the Conceptual Structure and Grammar theory of kin terminology. In that case, what are some directions the theory might take in the future?

Several commentators (**Behme, Bloch, and Levinson**) claim that there is little evidence for the psychological mechanisms proposed in the target article. But whatever truth there is in this charge stems not so much from any weakness of the theory as from the woefully underdeveloped state of the study of kinship and cognition. The information we have on kinship terminologies across cultures is currently some of our best evidence in this area, and a lot more could be done with it. However, the typological evidence needs to be supplemented with other linguistic evidence, from morphology, pragmatics (**Bloch, Hogeweg et al.**), and language history (**Jordan & Dunn**), and from semantic fields beyond kinship (**Bernardo**). And the methods of cognitive science, including developmental studies, need to be brought to bear.

The research reported by **Liu et al.** is an excellent example of what can be done. The authors correctly identify the major constraints active in Chinese kin terminology according to the present theory, and find significant effects in the expected direction for most of these (except for the relative age constraint) on the processing of kin terms. This is an important preliminary indication that work on kin terminology has identified real psychological processes. (For additional results along the same lines, comparing the processing of kinship formulas by English and Tongan speakers, see **Bernardo & Read 2010**.) It may turn out that **Levinson's** remark, “It is quite unwarranted (despite the normal claims of OT) to think that any one native speaker has this kind of meta-knowledge in his or her head,” is too skeptical.

Finally, it is possible that the future will demonstrate not just the psychological reality of some version of the machinery proposed here, but its broader value to the human sciences. In the study of grammar, for example, kin terminology may be of interest as involving an elementary variety of recursion more tractable than that found in syntax (**Read 2008**). And in the study of social cognition and social structure, the interplay of universals and variation in the rules dividing kin into marriageable and

non-marriageable may offer new insights into the combinatorial structure of moral systems. If the CS&G theory can develop as a progressive research program, kinship may emerge as a model system for the study of important issues in cognition and social organization.

## NOTES

1. In the target article (including Figs. 2 and 3) and the reply, DISTINGUISH MATRIKIN counts a man as a member of his mother's and sister's matrikin, and DISTINGUISH PATRIKIN counts a woman as a member of her father's and brother's patrikin. Suppose we revise this. Let DISTINGUISH MATRIKIN count a woman, her sisters, and her parents as members of one matrikin, and her brothers and their wives as members of an adjacent matrikin. And let DISTINGUISH PATRIKIN count a man, his brothers, and his parents as members of one patrikin, and his sisters and their husbands as members of an adjacent patrikin. This revision builds a parallel/cross-sibling distinction into both constraints. It also lumps wives and husbands together as parallel (members of the same matrikin and patrikin), but these can be separated by DISTINGUISH AFFINES as needed. There may be some advantages to this. Together with a new markedness constraint, MINIMIZE CROSS-SIBLINGS, the revised constraints can now handle parallel versus cross-sibling terms (e.g., Woman's Sister versus Man's Sister). See Jones (2010) for details; either of the revised constraints here is equivalent to DBIF there.

2. DISTINGUISH MATRIKIN bars mergers of cross cousins with parents' children. Here we spell this out on a case-by-case basis (with standard abbreviations including Z for Sister): Mother's Brother's Child (MBC) → Father's Child (FC) is barred because MB and F are in adjacent matriline; MBC → MC is barred because MBC and MC are in adjacent matriline; FZC → MC is barred because FZ and M are in adjacent matriline; FZC → FC is barred because FZC and FC are in adjacent matriline.

3. How this works: Mother's Sister's Child (MZC) is not indexed as falling either inside Ego's patriline or in an adjacent one. So DISTINGUISH PATRIKIN allows this kin type to merge either with FBC (Ego's patriline) or with MBC and FZC (adjacent patriline). The decision falls to a lower ranking constraint. Here we assume that DISTINGUISH SEX assigns more constraint violations to the double sex change in MZC → FBC, thus pushing MZC to merge with non-patrilineal cousins instead. However, if the ranking were changed by inserting DISTINGUISH MATRIKIN above DISTINGUISH SEX, the decision would go the other way, resulting in a merger of MZC and FBC, and a distinction between siblings, parallel cousins, and cross cousins, as seen in other (Sudanic) terminologies.

4. The rules are:

1. Replace a doubly embedded parent's sibling (\_\_\_Parent's Sibling's\_\_\_) with a doubly embedded parent of the appropriate sex.

2. Replace a singly embedded parent's sibling (Parent's Sibling's\_\_\_) with a singly embedded parent of the appropriate sex only if this is consistent with DISTINGUISH MATRIKIN, and

3. Replace a parent's child with a sibling of the appropriate sex.

The result, applied to Kay's formula, and using standard abbreviations including S for Son and Z for Sister, is FMFMBDSSC → FMFFDSSC → FMEZSSC → FMMSSC → FMBSC → FFSC → FBC → FC → Sibling, where underline and **bold** show what will be and has been rewritten. The role of Optimality Theory here is to put constraints on possible replacement rules – in this case producing a markedness effect where unilineal distinctions are neutralized in processing more distant cousin terms.

5. Some more details; put one of the following constraints: DISTINGUISH MATRIKIN, DISTINGUISH PATRIKIN, or, if you

insist, DISTINGUISH PARALLEL/CROSS, in one of the places marked by a number in the following ranking:

(1) » MINIMIZE \_\_\_ PARENTS' SIBLINGS' \_\_\_ » DISTINGUISH AFFINES » (2) » MINIMIZE PARENTS' SIBLINGS' \_\_\_ » (3) » MINIMIZE PARENT'S SIBLINGS » (4).

The corresponding kin terminologies are:

(1) Dravidian. Four replacement rules,

(a) MZ → M,

(b) FB → F,

(c) \_\_\_MB\_\_\_ → \_\_\_EF\_\_\_,

(d) \_\_\_FZ\_\_\_ → \_\_\_EM\_\_\_,

where E is Spouse. Also, nothing bars the standard replacements Parent's Child → Sibling and Parent's Spouse → Parent. The result, applied to Kay's formula, is FMFMBDSSC → FMFFDSSC → FMEZSSC → FMMZSSC → FMMSSC → FMBSC → FEFSC → FEBC → MBC = 'cross cousin.' Moving DISTINGUISH AFFINES further down in the ranking can result in a stronger version of Dravidian terminology, with rules like MB → EF and FZ → EM, and 'cross cousin' further reduced to 'spouse' or 'spouse's sibling.'

(2) Iroquois. See replacement rules in the previous note, and discussion of Seneca in target article.

(3) Cheyenne. Cousins equated with siblings, bifurcate merging aunts and uncles.

(4) Generational. Cousins equated with siblings, aunts and uncles equated with parents.

We assume generational distinctions rank high and distance distinctions low. On this account, Dravidian and Iroquois cousin terms fall along a markedness gradient with respect to unilineal or parallel/cross distinctions, addressing the concerns of **Kronfeld** and **McConvell** about where Seneca extended cousins fit into the larger picture.

## References

[The letters "a" and "r" before author's initials stand for target article and response references, respectively.]

- Ackerman, C. (1976) Omaha and "Omaha." *American Ethnologist* 3(4):555–72. [PMi]
- Aissen, J. (1999) Markedness and subject choice in optimality theory. *Natural Language and Linguistic Theory* 17:673–711. [aDJ]
- Allen, N. J. (1998) The prehistory of Dravidian-type terminologies. In: *Transformations of kinship*, ed. M. Godelier, T. R. Trautmann & F. E. Tjón Sie Fat, pp. 314–31. Smithsonian Institution Press. [CS]
- Alvard, M. (2003) Kinship, lineage identity, and an evolutionary perspective on the structure of cooperative big game hunting groups in Indonesia. *Human Nature* 14:129–63. [DG, rDJ]
- Alvard, M. & Nolin, D. A. (2002) Rousseau's whale hunt? Coordination among big game hunters. *Current Anthropology* 43(4):533–59. [DG]
- Anderson, J. M. (1992) *Linguistic representation: Structural analogy and stratification*. Mouton de Gruyter. [AN]
- Anttila, A. & Young-Mee, Y. C. (1998) Variation and change in optimality theory. *Lingua* 104:31–56. [PMc]
- Arbib, M., Liebal, K. & Pika, S. (2008) Primate vocalization, gesture, and the evolution of human language. *Current Anthropology* 49:1053–63. [CB]
- Archangeli, D. & Langendoen, D. T., ed. (1997) *Optimality theory: An overview*. Blackwell. [aDJ]
- Archangeli, D. & Pulleyblank, D. (1994) *Grounded Phonology*. MIT Press. [AN]
- Behme, C. & Deacon, H. (2008) Language learning in infancy: Does the empirical evidence support a domain specific language acquisition device? *Philosophical Psychology* 21(5):641–71. [CB]
- Bennardo, G. (2009) *Language, space, and social relationships: A foundational cultural model in Polynesia*. Cambridge University Press. [GB, SML]
- Bennardo, G. & Read, D. W. (2007) Cognition, algebra, and culture in the Tongan kinship terminology. *Journal of Cognition and Culture* 7(2):49–88. [GB, DWR]
- Bennardo, G. & Read, D. (2010) Salience of verticality and horizontality in American and Tongan kinship terminologies. In: *Kinship, language, and prehistory: Per Hage and the renaissance in kinship studies*, ed. D. Jones & B. Milicic, pp. 173–91. University of Utah. [rDJ]

- Benson, N. J. & Anglin, J. M. (1987) The child's knowledge of English kin terms. *First Language* 7(19):41–66. [FMJ]
- Bergman, T., Beehner, J., Cheney, D. L. & Seyfarth, R. M. (2003) Hierarchical classification by rank and kinship in baboons. *Science* 302:1234–36. [RMS]
- Bermúdez-Otero, R. & Börjars K. (2006) Markedness in phonology and syntax: The problem of grounding. *Lingua* 116:710–56. [aDJ]
- Bierwisch, M. (1996) How much space gets into language? In: *Language and space*, ed. P. Bloom, M. A. Peterson, L. Nadel & M. F. Garrett, pp. 31–76. MIT Press. [aDJ]
- Biró, T. (2006) *Finding the right words: Implementing optimality theory with simulated annealing*. PhD thesis. GroDiL 62. Groningen. Available online at: <http://www.biroth.hu/publications/dissertation/dissertation.pdf> and <http://dissertations.ub.rug.nl/faculties/arts/2006/t.s.biro/>. [TB]
- Biró, T. (2009) Elephants and optimality again: SA-OT accounts for pronoun resolution in child language. In: *Computational linguistics in the Netherlands 2009*. LOT Occasional Series 14, ed. B. Plank, E. Tjong Kim Sang & T. Van de Cruys, pp. 9–24. Landelijke Onderzoekschool Taalwetenschap. [TB]
- Biró, T. (in press) Optimal religion. Optimality theory accounts for ritual dynamics. In: *Changing minds. Religion and cognition through the ages*, ed. I. Czachesz & T. Biró. Peeters Publishers. [TB]
- Bloom, P. (2000) *How children learn the meanings of words*. MIT Press. [aDJ]
- Blutner, R., Hoop, H. D. & Hendriks, P. (2006) *Optimal communication*. Center for the Study of Language and Information. [aDJ]
- Botha, R. (1999) On Chomsky's "fable" of instantaneous language evolution. *Language and Communication* 19:243–57. [CB]
- Brentari, D. (1998) *A prosodic model of sign language phonology*. MIT Press. [rDJ]
- Breuker, C. J., Debat, V. & Klingenberg, C. P. (2006) Functional evo-devo. *Trends in Ecology & Evolution* 21(9):488–92. [FMJ]
- Buchler, I. & Selby, H. A. (1968) *Kinship and social organization: An introduction to theory and method*. Macmillan. [aDJ]
- Burling, R. (1964) Cognition and componential analysis: God's truth or hocus-pocus? *American Anthropologist* 66(1):20–28. [AW]
- Calabrese, A. (2005) Markedness and economy in a derivational model of phonology. Mouton de Gruyter. [AN]
- Carsten, J. (1997) *The heat of the hearth: The process of kinship in a Malay fishing community*. Clarendon Press; Oxford University Press. [aDJ], [SML]
- Chagnon, N. A. (2000) Manipulating kinship rules: A form of male Yanomamö reproductive competition. In: *Adaptation and human behavior: An anthropological perspective*, ed. L. Cronk, N. Chagnon & W. Irons, pp. 115–31. Aldine de Gruyter. [DG]
- Chapais, B. (2008) *Primeval kinship: How pair-bonding gave birth to human society*. Harvard University Press. [PMI]
- Chen, T. S. & Shryock, J. K. (1932) Chinese relationship terms. *American Anthropologist* 34:623–64. [CL]
- Cheney, D. L. & Seyfarth, R. M. (2007) *Baboon metaphysics: The evolution of a social mind*. University of Chicago Press. [rDJ], [RMS]
- Chomsky, N. (1965) *Aspects of the theory of syntax*. MIT Press. [SM]
- Chomsky, N. & Halle, M. (1968) *The sound pattern of English*. Harper & Row. [SM]
- Christiansen, M. & Chater, N. (2008) Language as shaped by the brain. *Behavioral and Brain Sciences* 31:489–558. [CB]
- Coult, A. (1966) A simplified method for the transformational analysis of kin terms. *American Anthropologist* 68:1476–83. [rDJ]
- Cronk, L. (2007) The influence of cultural framing on play in the trust game: A Maasai example. *Evolution and Human Behavior* 28:352–58. [DG]
- Cronk, L. & Gerkey, D. (2007) Kinship and descent. In: *The Oxford handbook of evolutionary psychology*, ed. R. Dunbar & L. Barrett, pp. 463–78. Oxford University Press. [DG]
- Cronk, L. & Wasielewski, H. (2008) An unfamiliar social norm rapidly produces framing effects in an economic game. *Journal of Evolutionary Psychology* 6(4):283–308. [DG]
- Dahl, Ö. & Koptjevskaja-Tamm, M. (2001) Kinship in grammar. In: *Dimensions of possession*, ed. I. Baron, M. Herslund & F. Sørensen, pp. 201–25. John Benjamins. [aDJ]
- D'Andrade, R. G. (1971) Procedures for predicting kinship terminology from features of social organization. In: *Explorations in mathematical anthropology*, ed. P. Kay, pp. 60–75. MIT Press. [aDJ]
- D'Andrade, R. (1995) *The development of cognitive anthropology*. Cambridge University Press. [AW]
- Deacon, T. (2007) The evolution of language systems in the human brain. *Evolution of Nervous Systems* 4:529–47. [CB]
- Diesendruck, G. & Markson L. (2001) Children's avoidance of lexical overlap: A pragmatic account. *Developmental Psychology* 37:630–44. [aDJ]
- Dowe, D. L. (2008) Foreword re C. S. Wallace. *Computer Journal* 51(5):523–60. [SM]
- Dresher, E. (2009) *The contrastive hierarchy in phonology*. Cambridge University Press. [AN]
- Edelman, S. & Waterfall, H. (2007) Behavioral and computational aspects of language and its acquisition. *Physics of Life Reviews* 4:253–77. [CB]
- Efferson, C., Lalive, R. & Fehr, E. (2008) The coevolution of cultural groups and in-group favoritism. *Science* 321:1844–49. [DG]
- El Guindi, F. (2006) *Shared knowledge, embodied structure, mediated process: The case of the Zapotec of Oaxaca*. Paper presented at the Cognitive Science 2006, 28th Annual Conference of Cognitive Science Society, Vancouver, British Columbia, Canada. [FEG]
- El Guindi, F. (2008) *By noon prayer: The rhythm of Islam*. Berg Publishers. [FEG]
- El Guindi, F. (2009–2010) *UREP 06-012-5-003-milk kinship: The Khaliji Case*. Qatar Foundation. [FEG]
- Elman, J., Bates, E., Johnson, M., Karmiloff-Smith, A., Parisi, D. & Plunkett, K. (1996) *Rethinking innateness: A connectionist perspective on development*. MIT Press. [CB]
- Evans, N. (1999) Kinship verbs. In: *Approaches to the typology of word classes*, ed. P. M. Vogel & B. Comrie. Mouton de Gruyter. [aDJ]
- Evans, N. & Levinson, S. (2009) The myth of language universals: Language diversity and its importance for cognitive science. *Behavioral and Brain Sciences* 32:429–92. [CB, RH]
- Fischer, M. D. & Read, D. (2005) Kinship Algebra Expert System: A computer program and documentation for formal modelling of kinship terminologies and the simulation of populations that under these models. Retrieved 24 June, 2010, from <http://Kaes.anthrosciences.net>. [SML]
- Flemming, E. (1995) *Auditory representations in phonology*. Doctoral dissertation, UCLA, Los Angeles. [AN]
- Fogelson, R. (2001) Schneider confronts componential analyses. In: *The cultural analysis of kinship: The legacy of David M. Schneider*, ed. R. Feinberg & M. Ottenheimer, pp. 33–45. University of Illinois Press. [AW]
- Fong, V. (2005) Unmarked already: Aspectual expressions in two varieties of English. In: *Perspectives on aspect*, ed. H. J. Verkuyl, H. De Swart & A. van Hout, pp. 251–67. Springer. [LH]
- Fortunato, L. & Mace, R. (2009) Testing functional hypotheses about cross-cultural variation: A maximum-likelihood comparative analysis of Indo-European marriage practices. In: *Pattern and process in cultural evolution*, ed. S. J. Shennan, pp. 235–49. University of California Press. [FMJ]
- Fox, R. (1967) *Kinship and marriage: An anthropological perspective*. Penguin. [aDJ], [PMI]
- Fox, R. (1979) Kinship categories as natural categories. In: *Evolutionary biology and human social behavior: An anthropological perspective*, ed. N. A. Chagnon & W. Irons, pp. 132–44. Duxbury Press. [DG]
- Frank, S. A. (1998) *Foundations of social evolution*. Princeton University Press. [aDJ]
- Geertz, C. (1976) "From the native's point of view": On the nature of anthropological understanding. In: *Meaning in anthropology*, ed. K. Basso & H. A. Selby, pp. 221–37. University of New Mexico. [AW]
- Goddard, C., ed. (2008) *Cross-linguistic semantics*. John Benjamins. [AW]
- Goddard, C. (2010) Semantic molecules and semantic complexity (with special reference to "environmental" molecules) *Review of Cognitive Linguistics* 8(1):123–55. [AW]
- Goddard, C. & Wierzbicka, A., ed. (2002) *Meaning and universal grammar: Theory and empirical findings*. John Benjamins. [AW]
- Goddard, C. & Wierzbicka, A. (forthcoming) Men, women and children: The semantics of basic social categories. [AW]
- Godelier, M., Trautmann, T. R. & Tjon Sie Fat, F. E., ed. (1998) Introduction. In: *Transformations of kinship*, pp. 1–26. Smithsonian. [rDJ], [SCL]
- Goodenough, W. (1965) Yankee kinship terminology: A problem in componential analysis. *American Anthropologist* 67(5):259–87. [aDJ], [SML]
- Goodenough, W. (1967) Componential analysis. *Science* 67:1203–209. [aDJ], [AN]
- Gordon, M. (2007) Typology in optimality theory. *Language and Linguistics Compass* 1(6):750–69. [SM]
- Gould, S. (2000) *A new system for the formal analysis of kinship*. University Press of America. [arDJ], [DBK]
- Gray, R. D. & Atkinson, Q. D. (2003) Language-tree divergence times support the Anatolian theory of Indo-European origin. *Nature* 426(6965):435–39. [FMJ]
- Gray, R. D., Drummond, A. J. & Greenhill, S. J. (2009) Language phylogenies reveal expansion pulses and pauses in Pacific settlement. *Science* 323(5913):479–83. [FMJ]
- Gray, R. D., Greenhill, S. J. & Ross, R. M. (2007) The pleasures and perils of Darwinizing culture (with phylogenies) *Biological Theory* 2(4):360–75. [FMJ]
- Greenberg, J. H. (1966) *Language universals, with special reference to feature hierarchies*. Mouton. [aDJ], [AN]
- Greenberg, J. H. (1975) Research on language universals. *Annual Review of Anthropology* 4:75–94. [aDJ]
- Greenberg, J. H. (1990) Universals of kinship terminology: Their nature and the problem of their explanation. In: *On language: Selected writings of Joseph Greenberg*, ed. K. Denning & S. Kemmer, pp. 310–27. Stanford University Press. [aDJ]

- Grimshaw, J. (2005) *Words and structure*. Center for the Study of Words and Information. [aDJ]
- Hage, P. (1997) Unthinkable categories and the fundamental laws of kinship. *American Ethnologist* 24:652–67. [aDJ, CS]
- Hage, P. (2001) Marking theory and kinship analysis. *Anthropological Theory* 1:197–211. [aDJ, PMi]
- Halford, G. S., Wilson, W. H. & Phillips, S. (1998) Processing capacity defined by relational complexity: Implications for comparative, developmental, and cognitive psychology. *Behavioral and Brain Sciences* 21(6):831–64. [CL]
- Hamilton, W. D. (1964) The genetical evolution of social behaviour I and II. *Journal of Theoretical Biology* 7:1–16 and 17–52. [DG]
- Hauser, M. D., Chomsky, N. & Fitch, T. (2002) The faculty of language: What is it, who has it, and how did it evolve? *Science* 298:1569–79. [aDJ]
- Heck, F. & Müller, G. (2006) Extremely local optimization. In: *Proceedings of the Thirty-Fourth Western Conference of Linguistics, vol. 17*, ed. E. Bainbridge & B. Aghayani, pp. 170–82. Department of Linguistics, California State University, Fresno. [aDJ]
- Héritier, F. (1981) *L'Exercice de la parenté*. Le Seuil. [CS]
- Héritier, F. (1996) *Masculin/Féminin. La pensée de la différence*. Éditions Odile Jacob. [CS]
- Héritier, F. (2002) *Two sisters and their mother: The anthropology of incest*. Zone Books. [rDJ]
- Hirschfeld, L. (1989) Rethinking the acquisition of kin terms. *International Journal of Behavioral Development* 12(4):541–68. [aDJ, SCL]
- Hogeweg, L. (2009) *Word in process: On the interpretation, acquisition and production of words*. Ph.D. dissertation, Radboud University Nijmegen. [LH]
- Holden, C. J. (2002) Bantu language trees reflect the spread of farming across sub-Saharan Africa: A maximum-parsimony analysis. *Proceedings of the Royal Society of London Series B-Biological Sciences* 269(1493):793–99. [FMJ]
- Holden, C. J. & Mace, R. (2003) Spread of cattle led to the loss of matrilineal descent in Africa: A coevolutionary analysis. *Proceedings of the Royal Society of London Series B-Biological Sciences* 270(1532):2425–33. [FMJ]
- Huang, S. & Jia, W. (2000) The cultural connotations and communicative functions of Chinese kinship terms. *American Communication Journal* 3(3). [http://acjournal.org/holdings/vol3/Iss3/spec1/huang\\_jia.html](http://acjournal.org/holdings/vol3/Iss3/spec1/huang_jia.html). [CL]
- Hubert, H. (1905) Etude sommaire de la representation du temps dans la religion et dans la magie. *L'Année Sociologique, IV*. [FEG]
- Hudson, R. (1996) *Sociolinguistics*, 2nd edition. Cambridge University Press. [RH]
- Hudson, R. (2007) *Language networks: The new Word Grammar*. Oxford University Press. [RH]
- Hudson, R. (2009) Word grammar. In: *The Oxford handbook of linguistic analysis*, ed. B. Heine & H. Narrog, pp. 951–83. Oxford University Press. [RH]
- Hudson, R. (2010) *An introduction to Word Grammar*. Cambridge University Press. [RH]
- Hume, D. (1740) *A treatise of human nature. Book III: Of morals*. Thomas Longman. [DG]
- Hurford, J. (2003) The neural basis of predicate-argument structure. *Behavioral and Brain Sciences* 26:261–83. [aDJ]
- Hurford, J. (2007) *The origins of meaning*. Oxford. [aDJ]
- Ibn Khaldun, A. R. (1961) *Al-Muqaddimah*. Dar Ihra' al-Turath al-'Arabi. [FEG]
- Irons, W. (1981) Why lineage exogamy? In: *Natural selection and social behavior: Recent research and new theory*, ed. R. D. Alexander & D. W. Tinkle, pp. 476–89. Chiron. [DG]
- Jackendoff, R. (1983) *Semantics and cognition*. MIT Press. [aDJ]
- Jackendoff, R. (1991) Parts and boundaries. *Cognition* 41:9–45. [aDJ]
- Jackendoff, R. (1997) *The architecture of the language faculty*. MIT Press. [GB]
- Jackendoff, R. (2002) *Foundations of language: Bbrain, meaning, grammar, and evolution*. Oxford University Press. [GB, arDJ]
- Jones, D. (2000) Group nepotism and human kinship. *Current Anthropology* 41:779–809. [DG, rDJ, FMJ]
- Jones, D. (2003a) The generative psychology of kinship, Part I: Cognitive universals and evolutionary psychology. *Evolution and Human Behavior* 24:303–19. [aDJ, FMJ]
- Jones, D. (2003b) The generative psychology of kinship: Part II. Generating variation from universal building blocks with optimality theory. *Evolution and Human Behavior* 24:320–50. [arDJ, FMJ, SM, PMi]
- Jones, D. (2004) The universal psychology of kinship: Evidence from language. *Trends in Cognitive Sciences* 8(5):211–15. [TB, arDJ, FMJ, AW]
- Jones, D. (2010) Grammars of kinship and color: Cognitive universals and optimal communication. In: *Kinship, language, and prehistory: Per Hage and the renaissance in kinship studies*, ed. D. Jones & B. Milicic, pp. 196–211. University of Utah. [arDJ]
- Jordan, F. M. (in press) A phylogenetic analysis of the evolution of Austronesian sibling terminologies. *Human Biology*. [FMJ]
- Jordan, F. M. (forthcoming) Comparative phylogenetic methods and the study of pattern and process in kinship. In: *Kinship systems: Change and reconstruction*, ed. P. McConwell & I. Keen. [FMJ]
- Jordan, F. M., Gray, R. D., Greenhill, S. J. & Mace, R. (2009) Matrilineal residence is ancestral in Austronesian societies. *Proceedings of the Royal Society B: Biological Sciences* 276(1664):1957–64. [FMJ]
- Kapsalis, E. (2008) Matrilineal kinship and primate behavior. In: *Kinship and behavior in primates*, ed. B. Chapais & C. M. Berman, pp. 153–76. Oxford University Press. [PMi]
- Kay, P. (1975) The generative analysis of kinship semantics: A reanalysis of the Seneca data. *Foundations of Language* 13:201–14. [arDJ, PK]
- Kay, P. & Maffi, L. (1999) Color appearance and the emergence and evolution of basic color lexicons. *American Anthropologist* 101:743–60. [aDJ]
- Kay, P. & Regier, T. (2003) Resolving the question of color naming universals. *Proceedings of the National Academy of Sciences of the United States of America* 100(15):9085–89. [FMJ]
- Keesing, R. M. (1975) *Kin groups and social structure*. Holt, Rinehart and Winston. [aDJ]
- Kitchen, A., Ehret, C., Assefa, S. & Mulligan, C. J. (2009) Bayesian phylogenetic analysis of Semitic languages identifies an Early Bronze Age origin of Semitic in the Near East. *Proceedings of the Royal Society B: Biological Sciences* 276(1668):2703–10. [FMJ]
- Knight, C. (2008) Language co-evolved with the rule of law. *Mind and Society: Cognitive Studies in Economics and Social Sciences* 7(1):109–28. [CK]
- Knight, C. (2009) Language, ochre and the rule of law. In: *The cradle of language*, ed. R. Botha & C. Knight, pp. 281–303. Oxford University Press. [CK]
- Kroeber, A. L. (1909) Classificatory systems of relationship. *Journal of The Royal Anthropological Institute* 39:77–84. [aDJ]
- Kroeber, A. L. (1933) Process in the Chinese kinship system. *American Anthropologist* 35:151–57. [CL]
- Kronenfeld, D. B. (1996) *Plastic glasses and church fathers: Semantic extension from the ethnoscience tradition*. Oxford University Press. [aDJ]
- Kronenfeld, D. B. (2001) Introduction: The uses of formal analysis re cognitive and social issues. *Anthropological Theory* 1(2):147–72. [AW]
- Kronenfeld, D. B. (2006) Issues in the classification of kinship terminologies: Toward a new typology. *Anthropos* 101:203–19. [aDJ]
- Kronenfeld, D. B. (2009) *Fanti kinship and the analysis of kinship terminologies*. University of Illinois Press. [aDJ, PMc]
- Kuper, A. (2009) *Incest and influence*. Harvard University Press. [SCL]
- Lakoff, G. (1987) *Women, fire, and dangerous things: What categories reveal about the mind*. The University of Chicago Press. [GB]
- Lakoff, G. (1988) Cognitive semantics. In: *Meaning and mental representations*, ed. U. Eco, M. Santambrogio & P. Violi, pp. 119–54. Indiana University Press. [GB]
- Langergraber, K., Mitani, J. & Vigilant, L. (2009) Kinship and social bonds in female chimpanzees (*Pan troglodytes*). *American Journal of Primatology* 71:840–51. [RMS]
- Leaf, M. (1971) The Punjabi kinship terminology as a semantic system. *American Anthropologist* 73:545–54. [MJL]
- Leaf, M. J. (1979) *Man, mind, and science: A history of anthropology*. Columbia University Press. [SML]
- Leaf, M. J. (2005) The message is the medium: Language, culture, and informatics. *Cybernetics and Systems: An International Journal* 36(8):903–17. [SML]
- Leaf, M. J. (2006) Experimental-formal analysis of kinship. *Ethnology* 45(4):305–30. [aDJ, MJL, DWR, AW]
- Leaf, M. (2007) Empirical formalism. *Structure and Dynamics: eJournal of Anthropological and Related Sciences*: 2(1). <http://repositories.cdlib.org/imbs/socdyn/sdeas/vol2/iss1/art2>. [MJL]
- Leaf, M. (2009) *Human organizations and social theory: Pragmatism, pluralism, and adaptation*. University of Illinois Press. [MJL]
- Leaf, M. & Read, D. (2010) *Human social organization and the computational mind: Ethnology as a formal science*. Unpublished manuscript. [DWR]
- Legendre, G., Grimshaw, J. & Vikner, S., ed. (2001) *Optimality-theoretic syntax*. MIT Press. [aDJ]
- Legendre, G., Sorace, A. & Smolensky, P. (2006) The optimality theory – harmonic grammar connection. In: *The harmonic mind: From neural computation to optimality-theoretic grammar, vol. 2: Linguistic and philosophical implications*, ed. P. Smolensky & G. Legendre, pp. 339–402. MIT Press. [arDJ]
- Lehman, F. K. (F. K. L. Chit Hlaing) (1993) The relationship between genealogical and terminological structure in kinship terminologies. *Journal of Quantitative Anthropology* 4:95–122. [aDJ]
- Lehman, F. K. (F. K. L. Chit Hlaing) (2001) Aspects of a formalist theory of kinship: The functional basis of genealogical roots and some extensions in generalized alliance theory. *Anthropological Theory* 1:212–38. [aDJ]
- Lehman, F. K. & Bernardo, G. (2003) A computational approach to the cognition of space and its linguistic expression. *Mathematical Anthropology and Cultural Theory* 1(2):1–83. [GB]



- Levinson, S. C. (1977) *Social deixis in a Tamil village*. PhD thesis, University of California, University Microfilms, Berkeley. [SCL]
- Levinson, S. C. (2003a) Language and mind: Let's get the issues straight! In: *Language in mind: Advances in the study of language and cognition*, ed. D. Gentner & S. Goldin-Meadow, pp. 25–46. MIT Press. [SCL]
- Levinson, S. C. (2003b) *Space in language and cognition*. Cambridge University Press. [GB]
- Levinson, S. C. (2006a) Matrilineal clans and kin terms on Rossel Island. *Anthropological Linguistics* 48(1):1–43. [aD], SCL, DWR]
- Levinson, S. C. (2006b) On the human “interaction engine.” In: *Roots of human sociality: Culture, cognition and interaction*, ed. N. J. Enfield & S. C. Levinson, pp. 39–69. Berg. [aD]
- Levinson, S. C. & Wilkins, D. P. (2006) Patterns in the data: Towards a semantic typology of spatial descriptions. In: *Grammars of space: Explorations in cognitive diversity*, ed. S. C. Levinson & D. P. Wilkins, pp. 512–52. Cambridge University Press. [aD]
- Lévi-Strauss, C. (1963) *Structural anthropology*. Basic Books. [aD]
- Lévi-Strauss, C. (1969) *The elementary structures of kinship*. Beacon. [aD], CK]
- Lewis, D. K. (1969) *Convention: A philosophical study*. Harvard University Press. [DG]
- Lieberman, D., Tooby, J. & Cosmides, L. (2007) The architecture of human kin detection. *Nature* 445:727–31. [DG]
- Lindblom, B. (1986) Phonetic universals in vowel systems. In: *Experimental phonology*, ed. J. J. Ohala & J. J. Jaeger, pp. 13–44. Academic Press. [AN]
- Liu, C., Ge, Y., Schiller, L., Mai, X., Igoa, J. M. & Luo, Y. (submitted) Kinship representation differs across cultures: A comparison between Chinese and Spanish speakers. [CL]
- Loewenstein, J. & Gentner, D. (2005) Relational language and the development of relational mapping. *Cognitive Psychology* 50:315–53. [SCL]
- Lounsbury, F. (1964a) The structural analysis of kinship semantics. In: *Proceedings of the Ninth International Congress of Linguistics*, ed. H. G. Hunt, pp. 1073–93. Mouton. [aD], DBK, PK, CS]
- Lounsbury, F. (1964b) The formal analysis of Crow- and Omaha-type kinship terminologies. In: *Explorations in cultural anthropology: Essays in honor of George Peter Murdock*, ed. W. H. Goodenough, pp. 351–93. McGraw-Hill. [aD], DBK, PMi]
- Lounsbury, F. (1965) Another view of Trobriand kinship categories. In: *Formal semantic analysis*, ed. E. A. Hammel, pp. 142–86. American Anthropological Association. [rD]
- Lounsbury, F. (1969) A formal analysis of the Crow- and Omaha-type kinship terminologies. In: *Cognitive Anthropology*, ed. S. Tyler, pp. 212–53. Holt, Rinehart, Winston. [SCL]
- Lounsbury, F. G. (1964/1969) The structural analysis of kinship semantics. *Proceedings of the Ninth International Congress of Linguists*. Reprinted in: *Cognitive anthropology: Readings*, ed. S. A. Tyler, pp. 193–212. Holt, Rinehart and Winston. [PMc]
- Lowie, R. H. (1928) A note on relationship terminologies. *American Anthropologist* 30(2):263–67. [PMi]
- Lucy, J. A. (1997) The linguistics of “colour.” In: *Colour categories in thought and language*, ed. C. L. Hardin & L. Maffi, pp. 320–46. Cambridge University Press. [AW]
- Mace, R., Holden, C. J. & Shennan, S. ed., (2005) *The evolution of cultural diversity: A phylogenetic approach*. Left Coast Press & Berg. [FMJ]
- MacWhinney, B. (2005) Language evolution and human development. In: *Origins of the social mind: Evolutionary psychology and child development*, ed. D. Bjorklund & A. Pellegrini, pp. 383–410. Guilford. [CB]
- Majid, A., Nicholas J. Enfield & Miriam van Staden ed., (2006) *Parts of the body: Cross-linguistic categorisation (vol. 28, 2/3: special issue)* Elsevier. [FMJ]
- Mandler, J. M. (2004) *The foundations of mind: Origins of conceptual thought*. Oxford University Press. [GB]
- Marshall, L. (1976) *The !Kung of Nyae Nyae*. Harvard University Press. [DWR]
- McCarthy, J. J. (2001) *A thematic survey of optimality theory*. Cambridge University Press. [aD], SM]
- McCarthy, J. J. (2007a) *Hidden generalizations: Phonological opacity in optimality theory*. Equinox. [aD]
- McCarthy, J. J. (2007b) What is optimality theory? *Language and Linguistics Compass* 1(4):260–91. [FMJ]
- McConvell, P. (forthcoming) Omaha skewing in Australia: Overlays, dynamism and change. In: *Crossing cousins, marrying aunts, transforming kin: Beyond the Crow-Omaha Paradox*, ed. P. Whiteley & T. Trautman. University of Arizona Press. [PMc]
- McKinnon, S. (2005) On kinship and marriage: A critique of the genetic and gender calculus of evolutionary psychology. In: *Complexities: Beyond nature and nurture*, ed. S. McKinnon & S. Silverman, pp. 106–31. University of Chicago Press. [DG]
- Mikhail, J. (2007) Universal moral grammar: Theory, evidence and the future. *Trends in Cognitive Sciences* 11:143–52. [rD]
- Mitani, J. (2006) Reciprocal exchange in chimpanzees and other primates. In: *Cooperation in primates: Mechanisms and evolution*, ed. P. Kappeler & C. van Schaik, pp. 101–13. Springer-Verlag. [RMS]
- Monaghan, P. & Christiansen, M. (2008) Integration of multiple probabilistic cues in syntax acquisition. In: *Corpora in language acquisition research*, ed. H. Behrens, pp. 139–63. John Benjamins. [CB]
- Morgan, L. H. (1954/1851) *League of the Ho-de-no-sau-nee, or Iroquois (2 volumes)* Human Relations Area Files. [aD]
- Morgan, L. H. (1997/1871) *Systems of consanguinity and affinity of the human family*. University of Nebraska Press. [aD], CS]
- Morgan, L. H. (1877) *Ancient society or researches into the lines of human progress from savagery through barbarism to civilization*. Charles H. Kerr and Co. [MJL]
- Müller, G. (2003) *Local versus global optimization in syntax: A case study*. www.uni-leipzig.de/~muellerg/mu36.pdf. [aD]
- Muller, M. & Mitani, J. C. (2005) Conflict and cooperation in wild chimpanzees. In: *Advances in the study of behavior*, ed. P. J. B. Slater, J. Rosenblatt, C. T. Snowdon, T. Roper & M. Naguib, pp. 275–331. Elsevier. [RMS]
- Murdock, G. P. (1949) *Social structure*. The Free Press. [rD]
- Murdock, G. P. (1970) Kin term patterns and their distribution. *Ethnology* 9(2):165–208. [aD], SM]
- Needham, R. (1958) A structural analysis of Purum society. *American Anthropologist* 60:75–101. [aD]
- Nerlove, S. & Romney, A. K. (1967) Sibling terminology and cross-sex behavior. *American Anthropologist* 69:179–87. [aD]
- Nevins, A. (2010) *Locality in vowel harmony*. MIT Press. [AN]
- Nishida, T. (1983) Alpha status and agonistic alliance in wild chimpanzees (*Pan troglodytes schweinfurthii*). *Primates* 24:318–36. [RMS]
- Nolin, D. A. (2009) Social and genetic kinship in Lamalera food-sharing networks. Presentation to the 108th annual meeting of the American Anthropological Association, December 5, 2009, Philadelphia, PA. [DG]
- Nolin, D. A. (2010) Food-sharing networks in Lamalera, Indonesia: Reciprocity, kinship, and distance. *Human Nature* 21(3):243–68. [DG]
- Noyer, R. (1997) *Features, positions and affixes in autonomous morphological structure*. Garland Publishing. [AN]
- NSM Homepage: www.une.edu.au/bcss/linguistics/nsm/Bibliographical details. [AW]
- Nuyts, J. (2007) Cognitive linguistics and functional linguistics. In: *The Oxford handbook of cognitive linguistics*, ed. D. Geeraerts & H. Cuyckens, pp. 543–65. Oxford University Press. [RH]
- Palmer, R. A. (1934) *The North American Indians: An account of the American Indians north of Mexico, compiled from the original sources*. Smithsonian. [aD]
- Parkin, R. (1997) *Kinship: An introduction to basic concepts*. Blackwell. [aD]
- Parkin, R. (2009) What Shapiro and McKinnon are all about, and why kinship still needs anthropologists. *Social Anthropology/Antropologie Sociale* 17(2):158–70. [DWR]
- Penn, D. C., Holyoak, K. J. & Povinelli, D. J. (2008) Darwin's mistake: Explaining the discontinuity between human and nonhuman minds. *Behavioral and Brain Sciences* 31:109–78. [SCL, RMS]
- Pinker, S. (1989) *Learnability and cognition: The acquisition of argument structure*. MIT Press. [aD]
- Pinker, S. (2007) *The stuff of thought: Language as a window into human nature*. Viking. [aD]
- Prince, A. (2007) *Let the decimal system do it for you: A very simple utility function for OT*. Rutgers Optimality Archive #943–1207. roa.rutgers.edu. [aD]
- Prince, A. & Smolensky, P. (1997) Optimality: From neural networks to universal grammar. *Science* 275:1604–10. [DWR]
- Prince, A. & Smolensky, P. (2004) *Optimality theory: Constraint interaction in generative grammar*. Blackwell. Technical Report CU-CS-696-93, Department of Computer Science, University of Colorado at Boulder and Technical Report TR-2, Rutgers Center for Cognitive Science, Rutgers University, New Brunswick, NJ (1993). [LH]
- Prince, A. & Smolensky, P. (2004/1993) *Optimality theory: Constraint interaction in generative grammar*. Blackwell. [aD]
- Ragnarsdóttir, H. (1997) The acquisition of kinship concepts. In: *Language and thought in development*, ed. P. Broeder & J. Murre, pp. 73–94. Gunter Narr Verlag. [FMJ]
- Read, D. (1984) An algebraic account of the American kinship terminology. *Current Anthropology* 25:417–49. [aD], MJL]
- Read, D. (2001a) Formal analysis of kinship terminologies and its relationship to what constitutes kinship. *Anthropological Theory* 1(2):239–67. [aD], DBK, SML, CS]
- Read, D. (2001b) What is kinship? In: *The cultural analysis of kinship: The legacy of David Schneider and its implications for anthropological relativism*, ed. R. Feinberg & M. Ottenheimer, pp. 78–117. University of Illinois Press. [aD], MJL, DWR]
- Read, D. (2006) Kinship Algebra Expert System (KAES): A software implementation of a cultural theory. *Social Science Computer Review* 24(1):43–67. [MJL, SML]

- Read, D. (2007) Kinship theory: A paradigm shift. *Ethnology* 46:329–64. [MJL, DWR]
- Read, D. (2008) Working memory: A cognitive limit to non-human primate recursive thinking prior to hominid evolution. *Evolutionary Psychology* 6:676–724. [rDJ]
- Read, D. (2010) The logic and structure of kinship terminologies: Implications for theory and historical reconstructions. In: *Per Hage and the renaissance in kinship studies*, ed. D. Jones & B. Milicic, pp. 152–72. University of Utah Press. [DWR]
- Read, D. (submitted) Reconstructing the proto-Polynesian terminology: Kinship terminologies as evolving logical structures. In: *Kinship systems: Change and reconstruction*, ed. P. McConvell & I. Keen. University of Utah Press. [DWR]
- Read, D. & Behrens, C. (1990) KAES: An expert system for the algebraic analysis of kinship terminologies. *Journal of Quantitative Anthropology* 2:353–93. [MJL]
- Redington, M., Chater, N. & Finch, S. (1998) Distributional information: A powerful cue for acquiring syntactic categories. *Cognitive Science* 22:425–69. [CB]
- Romney, A. K. (1965) Kalmuk Mongol and the classification of lineal kinship terminologies. In: *Formal semantic analysis*, ed. E. A. Hammel, pp. 127–41. American Anthropological Association. [DBK]
- Romney, A. K. & D'Andrade, R. (1964) Cognitive aspects of English kinship. *American Anthropologist* 67:146–70. [aDJ, DBK]
- Romney, A. K. & D'Andrade, R. G. (1969) Cognitive aspects of English kin terms. In: *Cognitive anthropology*, ed. S. Tyler, pp. 369–96. Holt, Rinehart, Winston. [SCL]
- Rosch, E. (1978) Principles of categorization. In: *Cognition and categorization*, ed. E. Rosch & B. Lloyd, pp. 28–48. Erlbaum. [GB]
- Sagae, K., MacWhinney, B. & Lavie, A. (2004) Automatic parsing of parent–child interactions. *Behavior Research Methods, Instruments, and Computers* 36:113–26. [CB]
- Sahlins, M. (1976) *The use and abuse of biology: An anthropological critique of sociobiology*. The University of Michigan Press. [DG]
- Salazar, C. (2009) Are genes good to think with? In: *European kinship in the age of biotechnology*, ed. J. Edwards & C. Salazar, pp. 179–96. Berghahn Books. [CS]
- Scheffler, H. (1971) Dravidian-Iroquois: The Melanesian evidence. In *Anthropology in Oceania*, ed. L. R. Hiatt & E. Jayawardena, pp. 231–54. Angus and Robertson. [PMC]
- Scheffler, H. W. (1968) *Australian kin classification*. Cambridge University Press. [aDJ]
- Scheffler, H. W. & Lounsbury, F. G. (1971) *A study in structural semantics: The Siriono kinship system*. Prentice-Hall. [aDJ]
- Schino, G. (2001) Grooming, competition and social rank among female primates: A meta-analysis. *Animal Behaviour* 62:265–71. [RMS]
- Schino, G., Tiddi, B. & Polizzi di Sorrentino, E. (2006) Simultaneous classification by rank and kinship in Japanese macaques. *Animal Behaviour* 71:1069–74. [RMS]
- Schneider, D. (1984) *A critique of the study of kinship*. University of Michigan Press. [aDJ]
- Seyfarth, R. & Cheney, D. (2008) Primate social knowledge and the origins of language. *Mind and Society* 7:129–42. [aDJ]
- Seyfarth, R. M. & Cheney, D. L. (2010) Production, usage, and comprehension in animal vocalizations. *Brain & Language* 115:92–100. [RMS]
- Seyfarth, R. M., Cheney, D. L. & Bergman, T. J. (2005) Primate social cognition and the origins of language. *Trends in Cognitive Science* 9:264–66. [RMS]
- Shapiro, W. (2008) What human kinship is primarily about: Toward a critique of the new kinship studies. *Social Anthropology* 16:137–53. [aDJ, AW]
- Shore, B. (1996) *Culture in mind: Cognition, culture and the problem of meaning*. Oxford University Press. [AW]
- Silk, J. B., Altmann, J. & Alberts, S. C. (2006) Social relationships among adult female baboons (*Papio cynocephalus*). II: Variation in the quality and stability of social bonds. *Behavioral Ecology and Sociobiology* 61:197–204. [RMS]
- Silk, J. B., Beehner, J. C., Bergman, T., Crockett, C., Engh, A., Moscovice, L., Wittig, R., Seyfarth, R. M. & Cheney, D. L. (2010) Female chacma baboons form strong, equitable, and enduring social bonds. *Behavioral Ecology & Sociobiology* 64:1733–47. [RMS]
- Smolensky, P. & Legendre, G. (2006) Harmony optimization and the computational architecture of the mind/brain. In: *The harmonic mind: From neural computation to optimality-theoretic grammar, vol. 1: Cognitive architecture*, ed. P. Smolensky, & G. Legendre, pp. 3–61. MIT Press. [aDJ]
- Smolensky, P. & Legendre, G. (ed.) (2006) *The harmonic mind: From neural computation to optimality-theoretic grammar*. MIT Press. [TB]
- Solan, Z., Horn, D., Ruppin, E. & Edelman, S. (2005) Unsupervised learning of natural languages. *Proceedings of the National Academy of Science* 102:11629–34. [CB]
- Sousa, P. (2003) The fall of kinship: Towards an epidemiological explanation. *Journal of Cognition and Culture* 3(4):265–303. [aDJ, AW]
- Sperber, D. (1996) *Explaining culture: A naturalistic approach*. Wiley-Blackwell. [rDJ]
- Sperber, D. & Hirschfeld, L. (2004) The cognitive foundations of cultural stability and diversity. *Trends in Cognitive Sciences* 8:40–46. [rDJ]
- Sperber, D. & Wilson, D. (1995/1986) *Relevance: Communication and cognition*. Blackwell. [aDJ]
- Stone, L. (2000) *Kinship and gender: An introduction*. Westview. [aDJ]
- Strier, K. B. (2004) Patrilineal kinship and primate behavior. In: *Kinship and behavior in primates*, ed. B. Chapais & C. M. Berman, pp. 177–99. Oxford University Press. [PMi]
- Studdert-Kennedy, M. (1998) The particulate origins of language generativity. In: *Approaches to the evolution of language*, ed. J. Hurford, M. Studdert-Kennedy & C. Knight, pp. 202–21. Cambridge University Press. [CB]
- Sugden, R. (2004) *The economics of rights, co-operation, and welfare*. Second edition. Palgrave Macmillan. [DG]
- Talmy, L. (2000a) The relation of grammar to cognition. In: *Toward a cognitive semantics, vol. I*, ed. L. Talmy, pp. 21–96. Cambridge University Press. [aDJ]
- Talmy, L. (2000b) How language structures space. In: *Toward a cognitive semantics, vol. I*, ed. L. Talmy, pp. 177–254. Cambridge University Press. [aDJ]
- Tesar, B. & Smolensky, P. (2000) *Learnability in optimality theory*. MIT Press. [aDJ]
- Tomasello, M. (2003) *Constructing a language: A usage-based theory of language acquisition*. Harvard University Press. [CB]
- Tomasello, M. (2006) Acquiring linguistic constructions. In: *Handbook of child psychology*, ed. D. Kuhn & R. Siegler, pp. 255–98. Wiley. [CB]
- Tomasello, M. (2008) *Origins of human communication*. MIT Press. [CB]
- Tomasello, M., Carpenter, M., Call, J., Behne, T. & Moll, H. (2005) Understanding and sharing intentions: The origins of cultural cognition. *Behavioral and Brain Sciences* 28:675–735. [aDJ]
- Trautmann, T. R. (1987) *Lewis Henry Morgan and the invention of kinship*. University of California. [aDJ]
- Trautmann, T. R. & Barnes, R. H. (1998) “Dravidian,” “Iroquois,” and “Crow-Omaha” in North American perspective. In: *Transformations of kinship*, ed. M. Godelier, T. R. Trautmann & F. E. Tjon Sie Fat, pp. 27–58. Smithsonian Institution Press. [PMi]
- Van den Berghe, P. L. (1979) *Human family systems: An evolutionary view*. Elsevier. [DG]
- Wallace, A. F. C. & Atkins, J. (1960) The meaning of kinship terms. *American Anthropologist* 62:57–80. [aDJ]
- Wallace, A. F. C. & Atkins, J. (1969) The meaning of kinship terms. In: *Cognitive anthropology*, ed. S. Tyler, pp. 345–69. Holt, Rinehart and Winston. [AW]
- Wallace, C. S. (2005) *Statistical and inductive inference by minimum message length*. Springer Verlag. [SM]
- Watts, D. (1998) Coalitionary mate-guarding by wild chimpanzees at Ngogo, Kibale National Park, Uganda. *Behavioral Ecology & Sociobiology* 44:43–55. [RMS]
- White, D. R. (1997) Structural endogamy and the Graphe de Parenté. *Mathématiques, Informatique, et Sciences Humaines* 137:107–25. [PMi]
- Whiting, J. W. M., Burton, M. L., Romney, A. K., Moore, C. C. & White, D. R. (1988) A reanalysis of Murdock’s model for social structure based on optimal scaling. *Behavior Science Research* 22:23–40. [rDJ]
- Wierzbicka, A. (1992) *Semantics, culture, and cognition: Universal human concepts in culture-specific configurations*. Oxford University Press. [AW]
- Wierzbicka, A. (1996) *Semantics: Primes and universals*. Oxford University Press. [aDJ, AW]
- Wierzbicka, A. (2006) *English: Meaning and culture*. Oxford University Press. [AW]
- Wierzbicka, A. (2010) *Experience, evidence, and sense: The hidden cultural legacy of English*. Oxford University Press. [AW]
- Wierzbicka, A. (forthcoming) *Seven universals of kinship: Overcoming the Eurocentrism of kinship semantics through seven universal semantic molecules*. [AW]
- Wikan, U. (1978) The Omani xanith – A third gender role? *Man* 13(3) 473–75. [FEG]
- Wittig, R. & Boesch, C. (2003) The choice of post-conflict interactions in wild chimpanzees (*Pan troglodytes*). *Behaviour* 140:1527–59. [RMS]
- Wittig, R.M. (2010) Function and cognitive underpinnings of post-conflict affiliation in wild chimpanzees. In: *The mind of the chimpanzee: Ecological and experimental perspectives*, ed. E. Lonsdorf & P. Ross, pp. 208–19. University of Chicago Press. [RMS]
- Woolford, E. (1984) Universals and role options in kinship terminology: A synthesis of three formal approaches. *American Ethnologist* 11:771–90. [aDJ]
- Zeevat, H. (2002) Explaining presupposition triggers. In: *Information sharing*, ed. K. van Deemter & R. Kibble, pp. 61–87. CSLI Publications. [LH]
- Zwarts, J. (2004) Competition between word meanings: The polysemy of (A)Round. In: *Proceedings of SuB8*, ed. C. Meier & M. Weisgerber, pp. 349–60. University of Konstanz Linguistics Working Papers. [LH]
- Zwarts, J. (2008) Priorities in the production of prepositions. In: *The syntax and semantics of spatial P* (linguistic aktuell/linguistics today 120), ed. A. Asbury, J. Dotlačil, B. Gehrke & R. Nouwen, pp. 85–102. John Benjamins. [LH]