

Hydrobiology of hypersaline Sambhar salt Lake a Ramsar site, Rajasthan, India

Anupama P. Pathak* & Makarand N. Cherekar

School of Life Sciences (DST-FIST & UGC-SAP Sponsored),
Swami Ramanand Teerth Marathwada University, Nanded-431606, India

*[E-mail: anupama.micro@rediffmail.com]

Received 17 April 2013; revised 15 July 2013

Hydrobiology of Sambhar Salt Lake a Ramsar site, Rajasthan was studied with respect to their chemical composition of brine and extremely haloalkaliphilic. Chemical compositions of brine samples were analyzed. Brine had pH value of 11 and a total salt content 30% (w/v). The sodium chloride and sodium bicarbonate were principal salts of brine. Metals like Fe, Mn, Zn, Cu, As, Cr, Pb, and Cd were detected in significant amount. Total 64 morphologically distinct isolates were recovered from brine samples out of that five were confirmed as red extremely haloalkaliphilic archaeobacteria and identified by using 16S rRNA sequencing method. All five isolates were required high salt (10-30%) and alkaline pH (9-10) for their optimum growth and pigmentation. 16S rRNA sequencing revealed that selected isolates were members of *Natronococcus* genus.

[**Keywords:** Archaeobacteria, Haloalkaliphiles, Metals, *Natronococcus* sp., Sambhar Salt Lake, Ramsar site]

Introduction

The Sambhar Lake, one of the largest inland saline depression in western desert of India, is the largest and single salt source situated in Rajasthan state. It is saline alkaline lake located in Thar Desert of Rajasthan India (26° 52' - 27° 02' N, 74° 53' - 75° 13' E) (Fig.1)^{1,2,3}. It is an elliptical and shallow lake, with the maximum length of 22.5 km. The width of the lake ranges from 3.2 km to 11.2 km. The total catchments area of the lake is 7560 km², most of which lies to the north and northeast. The lake occupies an area of about approximately 225 Sq. Km and average depth of water is about 1 m whereas the maximum depth is about 3m^{4,7}. The principal source of water to the lake basin is atmospheric precipitation and inputs from seasonal streams mainly Roopangarh and Mendha rivers during the monsoon season (July to September). Sambhar has been declared as Ramsar site in 1990 for receiving large number of migratory birds like flamingos, pelicans every year, also this wetland serve as a wintering area for flamingos and other migratory birds from Northern Asia^{4,7}. Extreme saline and alkaline environment of this soda lake encouraged us to explore the hydrobiology with extreme haloalkaliphilic bacteria.

The main objective of this work to analysis the

chemical composition of Sambhar salt lake brine and characterization of haloalkaliphilic bacteria isolated from this peculiar aquatic system. We believe that the present investigation will help to enhance our knowledge about few polyextremophilic and uncommon bacteria.

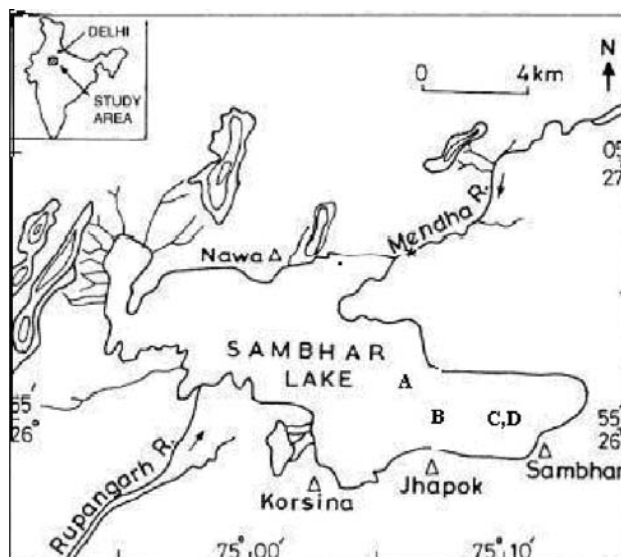

Fig. 1—Sampling locations (A, B, C and D) from Sambhar Salt lake (Adopted from Sinha et al. 2000)

Materials and Methods

Surface (SU) and Sediment (SD) Brine and water samples were collected from four different sampling stations located in main lake and kyars towards Sambhar Lake city. Samples were collected in summer in presterilized bottles. Samples collected from each station were average of ten samples spanning the whole sampling point (Fig 1).

The parameters like Temperature, pH were measured at the time of sampling by using Digital Thermometer and Digital pen pH meter respectively. Samples were transported to laboratory in cold box. The samples were filtered and stored in refrigerator during investigation⁸.

Various physicochemical parameters were determined for both the samples individually^{9,10}. TS, TDS, TSS were analyzed according to procedures described in APHA. The salinity was measured by using Refractometer (Erma, Tokyo). The dissolved oxygen content (DO) was determined by azide modification method, Biological oxygen demand (BOD) by 5 days incubation methods. Chemical oxygen demand (COD) was performed by potassium dichromate oxidation method. Chloride was determined by argentometric and sulphate by gravimetric methods. Sodium and potassium were measured directly using the flame photometer (Model Elico CL 361). Carbonate and bicarbonates were measured titrimetrically. Calcium and magnesium were determined by EDTA titrimetric method etc. Metal ions like Fe, Mn, Zn, As, Cr, Pb, Cu, and Cd were directly analyzed by atomic absorption spectrophotometer (Model S2 Thermo- USA)⁹

The 5ml brine samples were inoculated into the four different broth media such as Alkaliphilic media at pH- 10.0[A], Marine agar pH- 10.5 [MA], Nutrient broth at pH- 10.5 [ANA] with 30 % sodium chloride and Tindall's medium [T]¹¹⁻¹⁴. Inoculated media were incubated for 8 days in shaking incubator at 30°C temperature and 100 rpm speed. After enrichment samples were inoculated on respective agar media plates and plates were incubated at 30°C for 10-30 days. Medium supporting highest diversity and growth rate was selected for further investigation. All selected organisms were inoculated on the agar plates having various salt concentrations (5-30%) and effect of salt concentration on growth was determined. Effect of pH on growth of selected isolates was determined by varying pH of cultivation media in the range of 8-11 with an increment of 1¹³.

Out of 64 isolates five extreme haloalkaliphilic organisms were further characterized. Gram staining was performed by modified Dussalt method and size of isolate was measured¹⁵. Carotenoid pigments were extracted in acetone: methanol (1:1 v/v) as a solvent¹⁶. Absorption spectra were taken in a UV double beam spectrophotometer (Systronics 2201) in the wavelength range 300 - 700 nm.

16S rRNA analysis was performed by extracting DNA of isolates. For DNA extraction isolates were suspended in an extraction buffer (10 mM Tris HCL, pH 8.0; 1 mM EDTA, pH 8.0). Proteinase K solution was added to a final concentration of 100 ug/ml and incubated at 55°C for 2 h with continuous shaking. 0.5 M NaCl was added and incubated at 72°C for 30 min. DNA was extracted by phenol-chloroform extraction. DNA was washed with 70% ethanol and dissolved in Tris-EDTA buffer (pH 8.0). Extracted DNA was analyzed by electrophoresis on a 1% agarose gel and visualized by ethidium bromide staining¹⁷.

The amplification of 16S rRNA fragments were performed by using an (PCR) thermocycler, (Eppendorf) with 530F (5' GTGCCAGCAGCCGCGG 3') and 1392R (5' ACGGGCGGTGTGTAC 3') primer pair. PCR reaction mixture contained 1.5 mM MgCl₂, 200 uM dNTP mixture and 0.3 μM of each primer and 1 U of Taq DNA polymerase with a reaction mixture supplied by the manufacturer in a total volume of 100 μl. Reaction mixture was first denatured at 94°C for 3 min, followed denaturation at 94°C for 30 s, annealing at 52°C for 30 s and extension at 72°C for 1 min. Amplification was completed by a final extension step at 72°C for 7 min reaction was carried out for 30 cycles. PCR products were run on a 1% agarose gel. PCR products were purified by the PEG/NaCl method¹⁸ and directly sequenced using Applied Biosystem model 3730 DNA analyzer (Foster, California, USA). The 16S rRNA sequences were initially analyzed using BLAST program (www.ncbi.nlm.nih.gov/blast/blast.cgi). Multiple sequence alignments of approximately 800 base pair sequences were performed using CLUSTALW program version 2.1¹⁹. Phylogenetic tree was constructed using the neighbour joining method^{20,21}. Tree files were generated by PHYLIP and viewed by TREE VIEW program. Bootstrap analysis (1000 replications) was also carried out. The 16S rRNA sequences from GenBank used in the phylogenetic

analysis are shown in (Fig 2). The 16S rRNA sequences determined in this study are deposited in the GenBank database under accession numbers, JQ328187-JQ328189, KC434455 and KC434457.

Results and Discussion

The colour of brine sample was pale brown at the time of collection. Temperature of surface brine recorded during sample collection was 36°C, and aerial temperature was 43°C, considerable difference in aerial and water temperature was observed. Influence of high salt concentration could be the possible reason for reduced water temperature. Typical rotten egg like smell was experienced in the lake atmosphere. The pH recorded for brine water sample was around 11. Conductivity of lake brine was recorded as 752400 us/cm. High Total Solids and Total dissolved Solids were recorded as 587 g/l and 488.7 g/l respectively.

Table 1 —Abiotic characters of Sambhar Lake Brine sample

Sr. No.	Geological characteristics	
1	Surface area (km ²)	225
2	Mean depth (m) at wet season	3(1-3)
3	pH of Brine	11
4	Temperature °C	36
5	EC (umhos/cm)	752400
6	TS (g/l)	587
7	TDS (g/l)	488.7
<i>Cation concentration</i>		
8	Na ⁺ (g/l)	118.1
9	Ca ²⁺ (g/l)	0.002
10	K ⁺ (g/l)	1.96
11	Mg ²⁺ (g/l)	0.018
12	Fe (g/l)	0.076
13	Mn (g/l)	0.0052
<i>Anion concentration</i>		
14	CO ₃ ⁻ (g/l)	33.5
15	HCO ₃ ⁻ (g/l)	41.5
16	Cl ⁻ (g/l)	147.12
17	NO ₃ ⁻ (g/l)	1.07
18	SO ₄ ²⁻ (g/l)	42.1
19	PO ₄ ³⁻ (g/l)	0.51

Salinity was recorded by refractometer. It was highest for undiluted sample. Low rainfall and high temperature are the principal reasons for uncommon highest salinity of brine water. Some anionic and cationic concentrations of brine were recorded, among all dominating cations and anions were sodium (118

g/l) and chloride (147g/l) and the divalent cations Ca²⁺ (0.002g/l) and Mg²⁺ (0.018g/l). Carbonates (33.5 g/l) and sulphate (42.0g/l) anions also recorded in considerable amount (Table 1). Also high metal concentrations were recorded in the brine sample. The Trace amount of chromium (0.03mg/l) and arsenic (0.02mg/l) were recorded. The concentration of cobalt (9.1mg/l) was recorded higher as compared to other metal ions. Also lead (0.4mg/l), Zinc (0.62mg/l) cadmium (1.48mg/l), copper (2.1mg/l) were present in considerable amount in brine sample. Heavy metal ion concentration of Sambhar lake was compared with Great Salt lake and other saline lakes. The comparative analysis showed that Cobalt, Copper, Lead and Cadmium metal concentrations were far more than these lake data of metal ions²²⁻²⁴. Out of four broth media used alkaliphilic and Marine media have supported highest growth during enrichment. Agar media of same type have supported highest diversity and faster growth of haloalkaliphiles and therefore they were used in further investigation. Small colonies were appeared after incubation of 10 days, further incubation of 30 days have yielded large colonies. Colonies were round, entire, mucoid, opaque and pigmented with pink, orange and red colour. Presence of archaea was initially confirmed based on pigmentation pattern. Total 64 colonies were selected based on their distinguishing morphological features. Out of sixty four morphologically distinct isolates five rapidly growing extreme haloalkaliphiles were selected for further study and designated as SLA2, SLA3, SLA60, SLA61 and SLA62. Selected colonies were further inoculated and pure cultures were obtained^{11,13}.

Among five isolates SLA62 was Gram negative rod and remaining all were Gram positive cocci. These all organisms grew at pH ranging from 8-11 and NaCl concentrations from 15 to 32%. SLA60 showed maximum growth at pH 10 with 30% salt concentration, it also showed considerable growth at high temperature (45°C). The isolates SLA3, SLA61 and SLA62 were efficient producers of protease enzyme²⁵. Among five isolate SLA2 showed effective production of amylase and protease enzyme (Table 2).

Acetone: methanol (1:1 v/v) cell extract showing the absorption spectra at wavelengths of 370, and 490 nm, which is characteristics of the C₅₀ isoprenoid pigments. These spectra correspond to those of bacterioruberin, which is a characteristic feature of extremely halophilic archaea^{16,26}.

Table 2—Morphological and physiological analysis based identification of Sambhar salt Lake isolates

Sr. No.	Strain Number	SLA 60	SLA 2	SLA 3	SLA 61	SLA 62
1	Accession Number	JQ328187	JQ328188	JQ328189	KC434455	KC434457
2	Cell Morphology	Cocci	Cocci	Cocci	Cocci	rod
3	Gram Nature	+	+	+	+	-
4	Colony pigmentation	Orange red	Orange red	Orange	Pink	Red
5	Number of Isolates	4	2	2	3	2
6	Optimum NaCl (% w/v)	30	15	20	25	20
7	Salt range (% w/v)	20-32	10-20	15-25	20-30	15-25
8	Optimum pH	10	9	9	10	10
9	pH range	8.0-11	8.0-11	8.0-11	8.0-11	8.0-11
10	Nitrate reduction	+	+	+	+	+
11	Catalase activity	+	+	+	+	+
	Hydolysis of					
12	Starch	-	+	-	+	-
13	Gelatin	-	-	-	-	+
14	Casein	-	+	+	+	+

Table 3—Closest relatives of bacterial isolates from 16S rDNA library

Isolate	Water sample	Medium	Nearest neighbour	% similarity	Accession No.
SLA 60	SU	A	<i>Natraronococcus</i> sp.	99	JQ328187
SLA 61	SU	A	<i>Natronococcus xinjiangens</i>	97	KC434455
SLA 62	SD	MA	<i>Natronorubrm thiooxidans</i>	99	KC434457
SLA 2	SU	A	<i>Natraronococcus occultus</i>	97	JQ328188
SLA 3	SD	MA	<i>Natraronococcus</i> sp.	97	JQ328189

SD sediment water samples, SU surface water samples

Approximately 800 base pairs of 16S rRNA fragments were amplified from 5' terminus. Phylogenetic analysis of these sequences revealed that all selected clones fell into major domain of archaea. These all five isolates were belonged to phylum Euryarchaeota²⁷⁻²⁹.

Out of five isolate SLA3 and SLA60 showed 97-99% similarity with *Natronococcus* species and deposited in gene bank with JQ328189 and JQ328187 accession numbers respectively. The isolate SLA2 showed 97% identity with *Natronococcus occultus* and deposited in gene bank with JQ328188 accession number. Isolate SLA61 and SLA62 deposited in gene

bank with KC434455 and KC434455 accession numbers, showed 97-99% identity with *Natronococcus xinjiangens* and *Natronorubrm thiooxidans* respectively (Table 3). SLA2, SLA3 and SLA60 were earlier reported from lake Magadi, Kenya^{12,21}. All five isolates (SLA2, SLA3, SLA60, SLA61 and SLA62) are deposited in PG research laboratory number 5, School of Life Sciences, S.R.T.M. University, Nanded and accessible to all.

The total microbial counts as well as overall diversity were found poor. Mostly Red and pink colored colonies were dominating at high pH and NaCl concentrations.

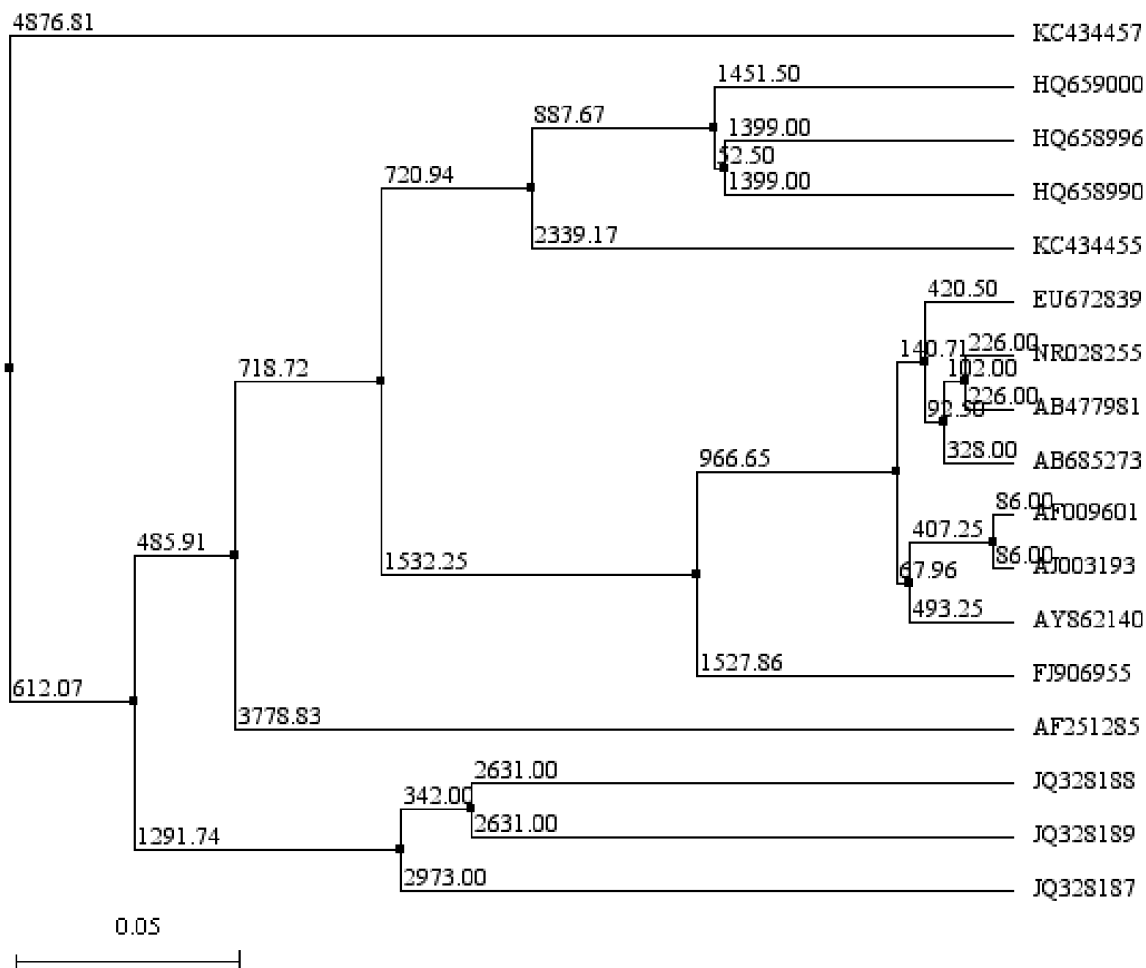

Fig. 2—Phylogenetic tree showing the relationship among 16S rRNA gene sequences from Sambhar Salt lake obtained in this study and related genera. This tree was constructed using the neighbour-joining method.

Conclusion

Sambhar lake brine samples were analyzed thoroughly. Overall hydrobiological analysis showed that the samples are halo alkaline in nature. The considerable amount of heavy metals like iron, zinc, cadmium and cobalt were also recorded. Microbiota of Sambhar lake brine showed poorest diversity. Presences of uncommon polyextremophiles like *Natronococcus sp.* have supposed the unique features of this ecosystem.

Acknowledgment

Authors are grateful to Hon. Vice Chancellor Dr. S. B. Nimse of Swami Ramanand Teerth Marathwada, University for providing infrastructure facility.

References

1. Biswas R.K., Chattopadhyay G.S. and Sinha S., Some observations on the salinity problems of the inland lakes of Rajasthan. Proc. Workshop on the problem of Deserts in India, Geological Survey of India, Jaipur. (1975): 68-79.
2. Yadav D.N., Sarin M.M., Ra-Po-Pb isotope systemics in waters of Sambhar Salt Lake, Rajasthan (India): geochemical characterization and particulate reactivity. *J. Environmental Radioactivity* 100 (2009): 17-22.
3. Yadav D.N., Sarin M.M., krishnaswami S., Hydrogeochemistry of Sambhar salt Lake, Rajasthan: Implication to recycling of salt and annual salt budget. *J. Geological society of India* 69 (2007): 139-152.
4. Shukal D and Rahaman A.A., Sambhar Lake a Wetland – An Assessment. Proc. Of the 1st International conference on the Ecological Importance of Solar Saltworks (CEISSA 06) Santorini Island, Greece. (2006)
5. Sinha R. and Raymahashan B.C., Evaporite mineralogy and

- geochemical evolution of the Sambhar Salt Lake, Rajasthan, India. *Sedimentary Geology*. 166 (2004): 59-71.
6. Sinha R. and Raymahashan B.C., Salinity model Inferred from Two Shallow cores at Sambhar salt lake, Rajasthan. *Geological society of India*. 56 (2000): 213-217.
 7. Upasani V.N., Microbiological studies on Sambhar lake (Salt of Earth). Rajasthan, India. Proc of Taal 2007: The 12th World Lake Conference (2008): 448-450.
 8. Bhadja P. and Kundu R., Status of the seawater quality at few industrially important coasts of Gujarat (India) off Arabian Sea, *Indian J Geomarine Sci*, 41 (2012): 954-61.
 9. Greenberg A., Clesceri L., Eaton A., *Standard methods for the examination of water and wastewater*, (American Public Health Association, New York), 1992, pp. 4-127.
 10. Trivedi R.K. and Goel P.K., *Chemical and Biological methods for water pollution studies* (Environment pollution V. C. College of Sci. Karad.) 1986
 11. Deshmukh K.B., Pathak A.P. and Karuppayil M.S., Bacterial Diversity of Lonar Soda Lake of India, *Indian J Microbio*. 51(1) (2011): 107-111.
 12. Tindall B.J, Ross H.N.M., Grant W.D., *Natronobacterium* gen. nov. and *Natronococcus* gen. nov., two new genera of haloalkaliphilic archaeobacteria. *Syst Appl Microbiol* 5(1984): 41-57.
 13. Upasani V.N., Sambhar Salt Lake: Chemical composition of the brines and studies on haloalkaliphilic archaeobacteria, *Archies of Microbiology*. 154 (1990): 589-593.
 14. Cherekar M.N., Pathak A.P., Chemical assessment of Sambhar Soda lake, a Ramsar site in India, *J. Water Chem. Technol* (2014) "in press"
 15. Dussault H.P., An improved technique for staining red halophilic bacteria, *Journal of Bacteriology*, 70 (1995): 484-485.
 16. Gochmauer, M. B., Kushwaha, S. C., Kates, M. & Kushner, D., Nutritional control of pigment and isoprenoid compound formation in extremely halophilic bacteria. *Arch Microbiol*. 84 (1972): 339-349.
 17. Yates C., Gilling M.R., Davison A.D., Altavilla N. and Veal D.A., PCR amplification of crude microbial DNA extracted from soil, *Lett Appl Microbiol.*, 25 (1997): 303-307.
 18. Ausubel F.M., Brent R., Kingston R.E., Moore D.D., Seidman J.G., Smith J.A., and Struhl K., *The polymerase chain reaction*. In: *Short protocols in molecular biology*, 5th Edn. Vol II (Wiley, New York), 2002.
 19. Thompson J.D., Higgins D.G., and Gibson T.J., CLUSTAL W: improving sensitivity of progressive multiple sequence alignments through sequence weighing, position-specific gap penalties and weight matrix choice, *Nucleic Acids Res.*, 22 (1994): 4673.
 20. Saitou N., Nei M., The neighbour joining method a new method for reconstructing phylogenetic trees. *Mol Biol Evol*. 4 (1987): 406-425.
 21. Duckworth A.W., Grant W.D., Jones B.E. and Van Steenberg R., Phylogenetic diversity of Soda Lake Alkaliphiles, *FEMS Microbiol Ecol.*, 19 (1996): 181-189
 22. Moore F., Forghani G. and Qishlaqi A., Assessment of heavy metal contamination in water and surface sediments of the Maharlu saline lake, sw Iran. *Iranian Journal of Science & Technology*, Transaction A, 33 (2009).
 23. Taher A.G. and Soliman A.A., Heavy metal concentrations in superficial sediments from Wadi El Natrum saline lakes. Egypt. *International Journal of Salt Lake Research*, 8 (1999): 75-92.
 24. Taylor P.L, Hutchinson L.A. and Muir M.R., *Great Salt Lake, A Scientific and Economic Overview*. (In: Artistic Printing. Gwinn, J.W.(Ed.), Utah, USA.), 1980, PP. 175-195.
 25. Claudia A.S., Rosana E. De Castro, Karina H. S. and Jorge J. S., Detection and preliminary characterizatoin of extracellular proteolytic activities of the haloalkaliphilic archaean *Natronococcus occultus*. *Archives of Microbiol*. 168 (1997): 532-535
 26. Grant,W. D., Kamekura,M., McGenity, T. J. & Ventosa, A., Class III. *Halobacteria* class. nov. In *Bergey's Manual of Systematic Bacteriology*, 2nd edn, vol. 1, pp. 294-301. Edited by D. R. Boone & R. W. Castenholz. New York, Berlin & Heidelberg: Springer-Verlag. 2001.
 27. Grant S., Grany W.D., Jones B.E., Kato C., Li L., Novel archeal phylotypes from an East African alkaline saltern. *Extremophiles*. 3 (1999): 139-145
 28. Oren A., Diversity of halophilic microorganisms: Environments, phylogeny, physiology, and applications. *Journal of Industrial Microbiology & Biotechnology* 28 (2002): 56-63
 29. Ress H.C., Grant W.D., Jones B.E., Diversity of Kenyan soda lake alkaliphiles assessed by molecular methods *Extremophiles*. 8 (2004): 63-71.