

Hydrogen Production Using Sea Water Electrolysis

H.K. Abdel-Aal*, K.M. Zohdy and M. Abdel Kareem

Higher Technological Institute, Tenth of Ramadan City, Egypt

Abstract: Electrolysis is one of the acknowledged means of generating chemical products from their native state. This is true for hydrogen production from water. The use of saline water (sea water in particular) as a feedstock for producing hydrogen by electrolysis is examined in this paper. Little consideration is given however, to the availability and the quality of the raw material used in the production of hydrogen; that is water. Under normal conditions of operation, the electrolysis cell behaves to produce H_2/Cl_2 rather than H_2/O_2 .

Experimental results are presented for the electrolysis of a wide range of saline water (0.5-7.0% TDS) and interpretations are given for two main cell-operating-characteristics. These are: rate of hydrogen production and chlorine evaluation.

Keywords: Seawater electrolysis, hydrogen, chlorine.

INTRODUCTION: WATER A FEEDSTOCK FOR HYDROGEN PRODUCTION

Solar energy provides electricity *via* photovoltaic cells. Sunlight reaching the land surface of our planet can produce the equivalence of 1,600 times the total energy consumption of the world; the amount of solar energy derived from the sun's radiation on just one square kilometer is about 4,000 megawatts, enough to light a small town [1, 2]. To produce hydrogen from seawater as a target product, an electrolysis production procedure can take three main routes:

- Electrolysis to give hydrogen, oxygen and alkalis;
- Electrolysis to give hydrogen, oxygen, chlorine and alkalis;
- Electrolysis to give hydrogen and sodium hypochlorite ($NaClO$).

Scientists, in studying hydrogen energy systems [3], have considered practically all facets of investigations starting from transitions to hydrogen, storage, distribution and ending with its conversation and utilization.

Little consideration is given however, to the availability and the quality of the raw material used in the production of hydrogen; that is water. It is true that water is predominating in our globe as manifested by the fact that about 75% of its surface is covered with water. Unfortunately, most of this water is saline water and has to be desalted prior to hydrogen production.

Water resources available for mankind are distributed between the atmosphere (water vapor), the hydrosphere (water of oceans and rivers), and the lithosphere (water in land aquifers and underground water). About 99% of the sum of the total water available including oceans, rivers, lakes, underground,...etc., is either salty water or locked up in ice in polar regions. The remaining fraction (1%) contributes the

fresh water needed for human life. But still, part of this fraction is underground water. This is illustrated in Fig. (1) [4].

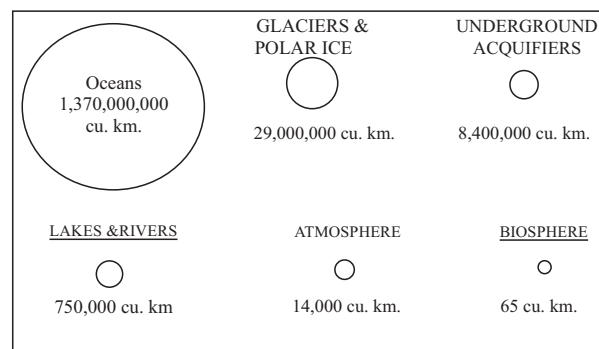

Fig. (1). Global water resources (Source: Reference [4]).

When we consider water as the raw material for hydrogen production, it would be an obvious advantage to utilize these abundant saline water resources for electrolysis, rather than using fresh water.

STATE OF THE ART

Alkaline water electrolysis is the technology used in present practice for large-scale electrolytic hydrogen production. Low efficiency, low current density and a lack of proper scale-up practice are the primary drawbacks of the present technology. Significant improvements have been made, making it possible to reach improved cell efficiencies and higher current densities. Many advanced concepts relating to various aspects of electrolytic hydrogen production are reported in the literature.

Alkaline water electrolysis uses fresh water with low salt content, and hence additional treatment and desalination systems add to the cost of hydrogen produced. Fig. (2) shows two established technologies of electrolysis, alkaline water electrolysis and brine electrolysis.

In the former, hydrogen is the main product, while in the later, caustic soda and chlorine are the primary products and

*Address correspondence to this author at the Higher Technological Institute, c/o 18 Jedah Street, Doki, Cairo, Egypt; Tel: 20 237499028; Cell: 20 015151806; Fax: + 20 15 364732; E-mail: habdelaal@link.net

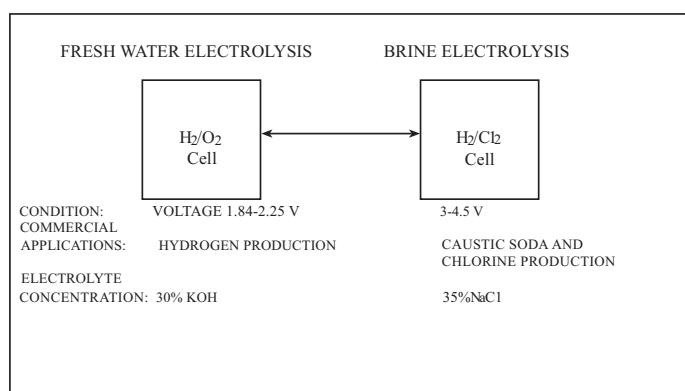

Fig. (2). Established technology of electrolysis.

hydrogen is a by-product. The cell for fresh water electrolysis is known as the H_2/O_2 cell, while for saturated brine electrolysis, it is described as the H_2/Cl_2 cell for caustic soda production. Hydrogen/oxygen is produced in the ratio of 2:1 in the former cell, while hydrogen/chlorine is produced in the molar ratio of 1:1 in the latter, as shown in the Fig. (3).

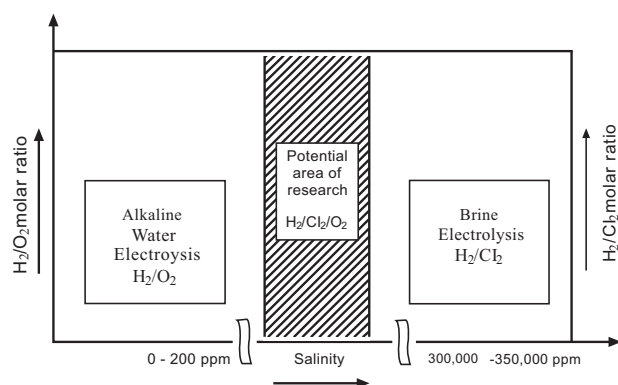

Fig. (3). Established technology of electrolysis vs. salinity.

As far as using saline water as a feedstock for producing hydrogen, it would be an obvious advantage if this water could be electrolyzed in a cell that behaves as a H_2/O_2 one. Under normal conditions of sea water electrolysis, however, mass transfer limitations and reaction kinetics combine to make the cell products H_2/Cl_2 .

A comparison among the well established electrolysis processes of alkaline water and brine vs. sea water electrolysis is compiled in Table 1. The only commercial application for saline water electrolysis has been reported for the cases of reducing fouling in process cooling water, and for treating and sterilizing water used for secondary recovery in oil fields. In these cases, the anodic product (chlorine) was of immediate interest to provide what is known as the "on-site hypochlorite" application.

THEORITICAL BACKGROUND

In the electrolysis of sea water as a source of hydrogen, two options exist for the performance of the electrolysis process [5]. The first option is to subject the water to total desalination to remove all dissolved salts and produce essentially distilled water. This distilled water can then be subjected to electrolysis, alkaline- electrolyte and electrolysis is cells.

The disadvantages of this approach are additional capital cost of water treatment and desalination system, and the environmental problems arising from the need to dispose the residual salts removed during desalination. The advantages are the ability to use developed technology for the direct electrolysis of fresh water.

The second option is to design an electrolyze system capable of utilizing sea water for direct electrolysis. It is probable that these systems would operate at a low power density and electrolyze only a small portion of the water in contact with electrodes. The disadvantages are many; new technology must be developed to solve the probable corrosion and contamination problems and the evolution of undesirable electrochemical products such as chlorine. The advantages are possible lower capital cost and natural elimination of the waste brine which is only slightly enriched with salts. It may also be possible to recover economically significant quantities of the metals present in sea water, in particular magnesium in a form of magnesium hydroxide.

It is towards this objective that the current research is directed to consider saline water in the range of 0.5-7% TDS (total dissolved solids) to be electrolyzed for hydrogen production. Abundant indigenous reserves are represented by underground water, sea water and rejects from water desalination MSF plants.

The two main factors contributing to the evolution of chlorine gas as the main anodic product rather than oxygen are reported to be as follows:

- (1) First, in un-buffered solution cause the solutions such as sea water, both oxygen and chlorine evolution which generates H^+ as follows:

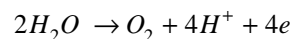

Any chlorine generated at the anode undergoes immediate hydrolysis which also generates H^+ as follows:

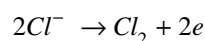
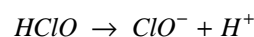

As the anode becomes more acidic, the thermodynamic voltage for oxygen evolution becomes more anodic, a trend

Table 1. Alkaline and Saline Water Electrolysis at a Glance

Technology	Conventional Alkaline Electrolysis	Brine Electrolysis	Sea Water Electrolysis
Development sage	Commercial large scale units	Commercial large scale units	Small laboratory scale
Cell voltage (V)	1.84-2.25	3.0-4.5	>2.1
Decomposition voltage(V)	1.47	2.31	2.1
Current density (mA cm ⁻²)	130-250	---	25-130
Temperature (°C)	70-90	60-70	23-25
Cathode	Nickel, steel, stainless steel	Ti coated with Pt	Pt
Anode	Ni	---	Pt
Cell type	H ₂ /O ₂	H ₂ /Cl ₂	H ₂ /(Cl ₂ /O ₂)
Electrolyte	25-35% KOH	NaCl	Sea water + drops of HCl
Salinity level	200-400 ppm	35%	3.4%
Chlorine current efficiency	---	95-97%	75-82%
Main product(s)	H ₂	Cl ₂ ,NaOH	H ₂
By-product(s)	O ₂	H ₂	Cl ₂ , NaOCl
Major advantages	Proven technology simple	Proven technology	Low cost
Disadvantages	Low efficiency Low current density Low production cost Corrosive electrolyte	Low efficiency	Within laboratory scale

favoring chlorine evolution which is independent of pH. As power is first applied to an anode, the theoretical voltage for oxygen evolution will therefore become more anodic according to equation (1):

$$E_{O_2} = 1.23 + \frac{RT}{F} \log(a_{H^+}) + \frac{RT}{4F} \log P_{O_2} \quad (1)$$

The steady-state pH of the solution adjacent to the anode, and hence the voltage at which the anode operates during continuous electrolysis, is dependent primarily on conditions of flow rate and current density.

- (2) The second factor which then inhibits the evolution of oxygen is its well-known high over potential at practical current densities. Bennett [6] showed experimentally that the effective anode pH – under practical conditions of electrolysis - is about pH 1-2, and even when the effective anode pH becomes very low, oxygen evolution is thermodynamically preferred to chlorine evolution because the equilibrium potential of oxygen evolution is lower than those of chlorine (as shown in Fig. 4), by about 200 mV.

This analysis is incomplete, however since thermodynamic voltages are valid only at zero current flow. The difficulty of evolving oxygen relative to chlorine is illustrated by a comparison of their exchange current densities which is an indicator of the ability of an electrode to catalyze a given electrochemical reaction. The ratio of exchange current densities for chlorine and oxygen evolution on most anode materials is very high in the range of:

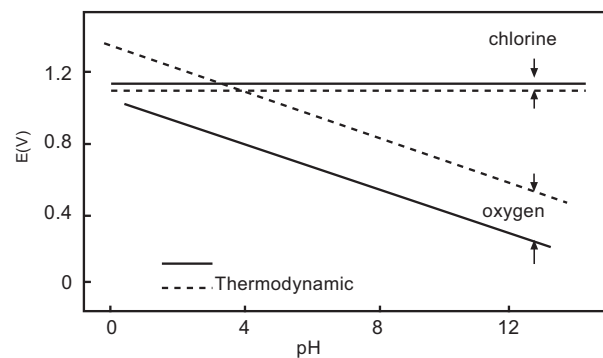

Fig. (4). Potential – pH diagram (Source: Ref. [5]).

$$\frac{i_{oCl_2}}{i_{oO_2}} = 1 \times 10^3 \text{ to } 1 \times 10^7 \quad (2)$$

which is a measure of the ease of evolving chlorine relative to oxygen.

The voltage range for the decomposition of a H₂-Cl₂ cell is between 1.8-2.2 V depending on current density. The H₂-Cl₂ cell begins to function at a higher applied potential difference than the H₂-O₂ cell. The evolution of Cl₂ will replace O₂ evolution between 1.8 and 2.2 V [7]. However, the transport of ions to the electrode is limited, whereas there is no corresponding problem with the availability of water. Hence, there will be a potential sufficiently high at which there will be no increase in evolution rate of Cl₂, whereas that of O₂ will increase with potential. A precise calculation of the

transport control of chlorine ions will depend (as with the pH at the interface) upon a knowledge of the transport conditions, e.g., natural and forced convection. Therefore, electrolysis of sea water at low current density $< 1 \text{ mA cm}^{-2}$, will result in exclusive evolution of oxygen, while operation far in excess of the limiting current for chloride oxidation will favor oxygen evolution. The limiting current in practical cells ranges from 100 to 1000 mA cm^{-2} , however, an operation at several thousand. mA cm^{-2} would be necessary to achieve high coulombic oxygen efficiency. This is also considered impractical since i.r. heating and power consumption would become unreasonably high at such current densities.

PRESENTATION AND ANALYSIS OF EXPERIMENTAL RESULTS

The experimental research findings presented next are based on the work by the author and co-workers on saline water electrolysis [8,9]. They are highlighted with emphasis on the following particular areas:

i. Hydrogen Production

In these experiments, electrolyses of both synthetic sea water and Arabian Gulf water were carried out using a simple Hoffman electrolysis apparatus. Details of the experimental arrangement are given in reference [10]. Simulated composition of sea water was chosen to cover the range all the way from brackish (say 4,000 ppm) to MSF desalination rejects (say 60,000 ppm). Electrolysis took place under the conditions of: 6-20 V, 25-126 mA/cm^2 and up to 1000 coulombs of electricity.

For the solutions investigated, it was found that the hydrogen production rate was dependent upon the applied current density alone. As can be seen from Fig. (5), the quantity of hydrogen produced on a platinum electrode of area 1.5835 cm^2 is 85 ml h^{-1} for 120 mA cm^{-2} current density. An efficiency of 99% is obtained for this electrolysis process.

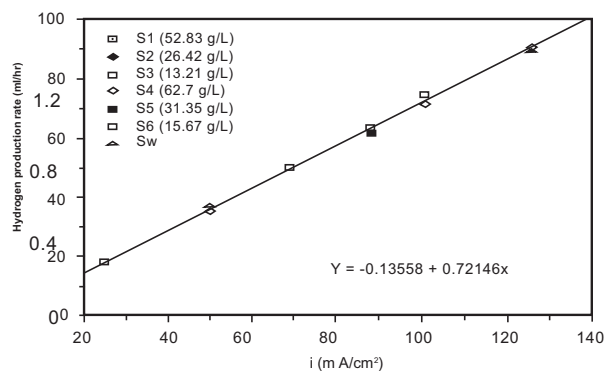

Fig. (5). Hydrogen production rate vs. current density for all solutions studied in this research.

The same conclusion is reached from Fig. (6), which is a plot of the hydrogen production rate vs. the TDS at different current densities.

On the other hand, Fig. (7) shows the relationship between hydrogen production rate and TDS for different voltages applied. Over the range of voltages used in these experiments (6-20V), the hydrogen production increases with the increase in TDS. This is attributed to the increase in conductivity of the salt, as shown in Fig. (8).

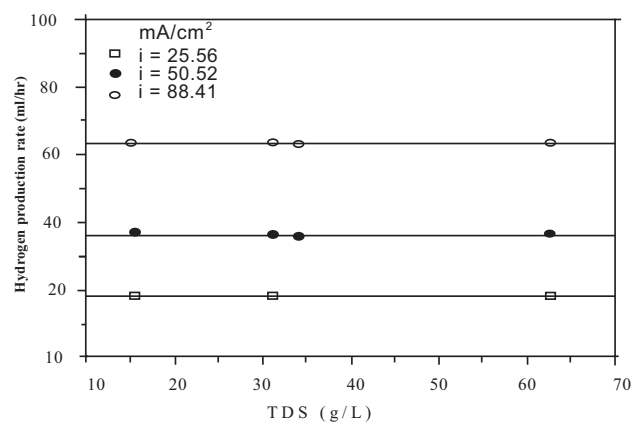

Fig. (6). Hydrogen production rate vs. TDS for synthetic sea water at different current densities.

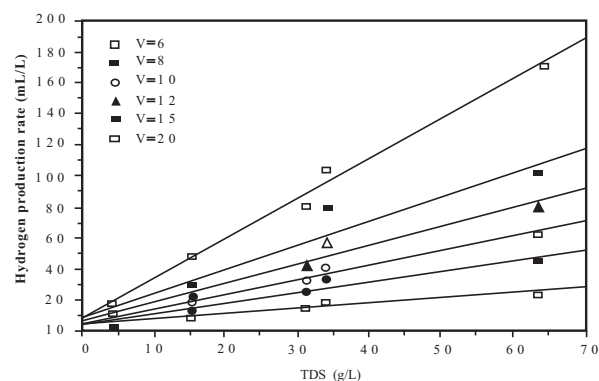

Fig. (7). Hydrogen production rate vs. TDS for sea waters at different voltages.

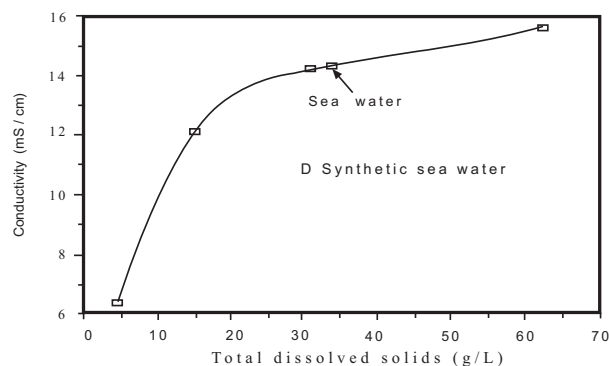

Fig. (8). Conductivity of synthetic and natural sea waters.

Similarly, the rate of hydrogen production increases ohmically (follows Ohm's law) with the increase in voltage for natural and synthetic seawater. However, the rate of increase at low values of voltage, say 6-8 V, is rather slow, since the production rate is dependent on the current density. At higher voltages (10 V and above), the initial conductivity is no longer affecting the current density and the solution behaves like a resistance, with lower resistance at high TDS; hence, the increase in salinity level gives a proportional increase in the hydrogen productivity.

Using such values of the current density in this investigation led to the evolution of chlorine, both in the gas and liq-

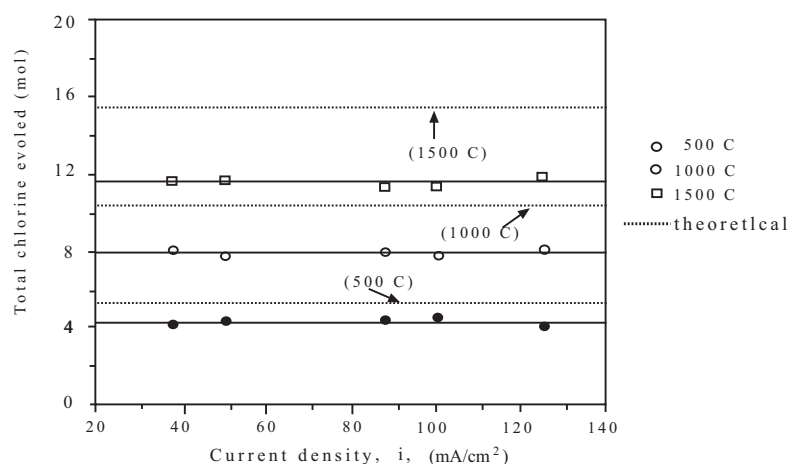
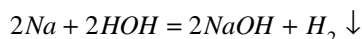

Fig. (9). Total chlorine evolved vs. current density for sea water for different coulombs.

uid phase [10]. Cells with almost chlorine-free anode gas are theoretically possible to operate, but at a low current density (less than 1 mA cm⁻²), a value too low to be of practical significance.

ii. Chlorine Evolution and Determination

As explained before, chlorine is a major anode gas product in the electrolysis of saline water containing chlorides [11, 12]. It evolves as a result of the reactions:



In reporting the evolution of chlorine during the electrolysis of saline water, distinction is made between chlorine evolved in the gas phase, in the liquid phase and total chlorine.

1. Total Chlorine Evolved

The total chlorine evolved, due to the passage of 1000 c of electricity is determined by adding the chlorine in the gas phase to the "available chlorine" in the liquid phase. The term "available chlorine" includes all free chlorine, hypochlorite and chlorite. The determination of either chlorine in the gas phase or available chlorine was achieved by the use of ascorbic acid.

a. Effect of Current Density on Total Chlorine

The effects of quantity of electricity as well as current density on chlorine evolved during sea water electrolysis are shown in Fig. (9).

It shows that the amount of chlorine evolved is proportional to the quantity of electricity applied and independent of current density for the range of current density and electricity quantity used in this experiment. Dotted lines represent the theoretical amounts of chlorine evolved as if the current passed was used totally for the production of chlorine (i.e. assuming a H₂-Cl₂ cell). The difference between the theoretical and the experimental curves corresponds to the oxygen evolved. Fig. (10) shows that chlorine evolution is independent of current density and that total chlorine Cl_T, in

mmol, is related to the quantity of electricity Q in coulombs by the relation:

$$Cl_T = 0.51913 + 7.37913 \times 10^{-3} Q$$

for the range (26.3-37.89) mA cm⁻²,

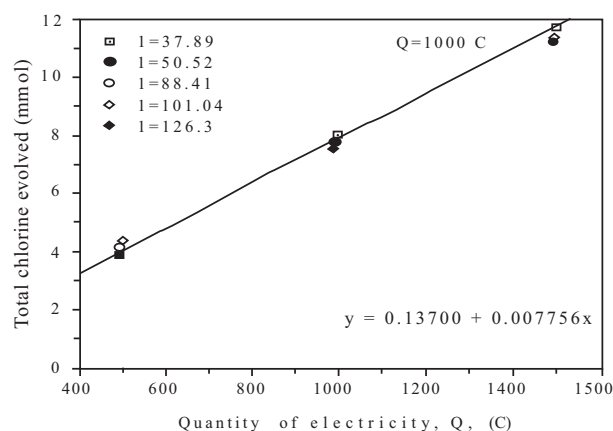

Fig. (10). Total chlorine evolved vs. quantity of electricity for sea water at different densities.

b. Effect of Voltage on Total Chlorine

Four different concentrations of synthetic sea water (NaCl + MgCl₂) in addition to natural sea water (Cl = 743.52 mmol⁻¹) are presented by their chloride concentration in Fig. (11).

The total amounts of chlorine produced at different voltages (6-15 V) are shown in the figure. In all cases, a quantity of electricity of 1000 C was passed. The total amount of chlorine Cl_T and chloride concentration C (in mmol⁻¹) are related by the equation:

$$Cl_T = 3.0918 + 3.8090 \log C .$$

At low chloride levels (< 600 mmol⁻¹), the amount of total chlorine evolved is low in the range 6-15 V, but it increases with the increase in the chloride content of the solution. This is explained as follows: at low chloride levels, the increase in chloride concentration results in a direct increase in solution conductivity as shown earlier (conductivity = 1.4235 + 8.3304 log TDS). This results in an increased cur-

rent density for operation at the same voltage. At high chloride concentrations ($> 600 \text{ mmol l}^{-1}$), the effect on conductivity is insignificant and the total chlorine evolved, is more or less the same, independent of the chloride concentrations, except for the case of 15 V which shows an increase as compared with other voltages applied.

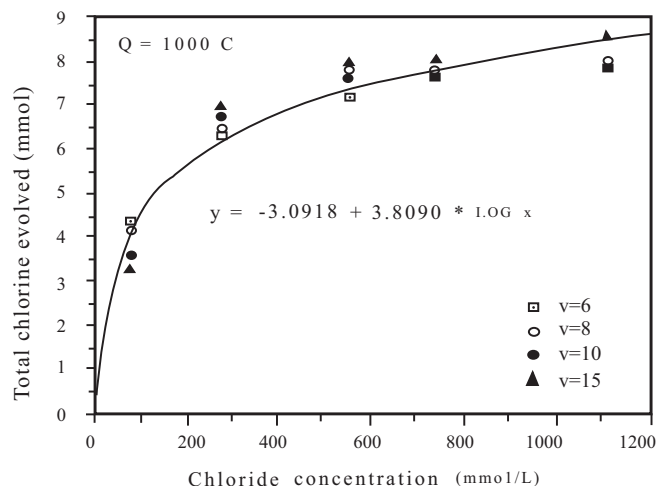

Fig. (11). Total chlorine evolved vs. chloride concentration for synthetic and natural sea waters.

2. Chlorine Efficiency

The quantity of electricity passed (either 500, 1000 or 1500 C) was monitored by measuring the current and time knowing that:

$$Q = A \int_0^t i t dt$$

where Q is the quantity of electricity passed (over a period of time, t) in coulombs, i is the current passing through the cell in A cm^{-2} , and A is the electrode surface area in cm^2 .

The current efficiency is then given by:

$$E_c = \frac{V_R (C_f - C_i) nF}{A \int_0^t i t dt}$$

where V_R is the volume of the reactor and C_i and C_f are the initial and final concentrations of chlorine in the cell. The value of $V_R (C_f - C_i) nF$ for chlorine if total chlorine evolved as free chlorine, chlorite and hypochlorite was easily determined by iodometric titrations using ascorbic acid.

3. Chlorine in the GAS PHASE

Fig. (12) shows results for natural sea water electrolysis. Chlorine is evolved in the gas phase at different current densities and for different quantities of electricity, namely 500, 1000 and 1500 C.

For 500 C, the anode product gas is almost chlorine-free, regardless of the current density ($38\text{-}126 \text{ mA cm}^{-2}$). This is mainly due to the absorption of chlorine evolved in the liquid phase. At intermediate values of electricity passed (1000 C), the behavior is almost the same; about 0.25 mmol of chlorine was produced in the cell. This is attributed to the enrichment

of the anolyte with chlorine evolved, especially in a poor mixing cell. At higher quantities of electricity, the performance of the cell changes to be current-density-dependent, with the following main features: At low current densities ($< 60 \text{ mA cm}^{-2}$), the chlorine evolved at 1500 C is 1.25 mmol, which is approximately 5 times that of 1000 C (a factor of 1.5 is expected if it is proportional to the quantity of electricity). This is mainly due to the fact that the anolyte is approaching saturation, if not saturated, with chlorine.

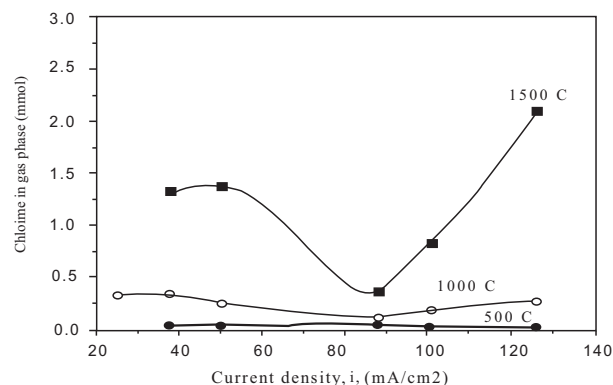

Fig. (12). Chlorine in gas phase vs. current density for sea water for different coulombs of electricity.

4. Hydrogen to Chlorine Ratio

For the electrolysis of saline water under investigation, and for a given operating condition, the ratio of hydrogen (produced at the cathode) to chlorine (evolved at the anode) is presented by Fig. (13).

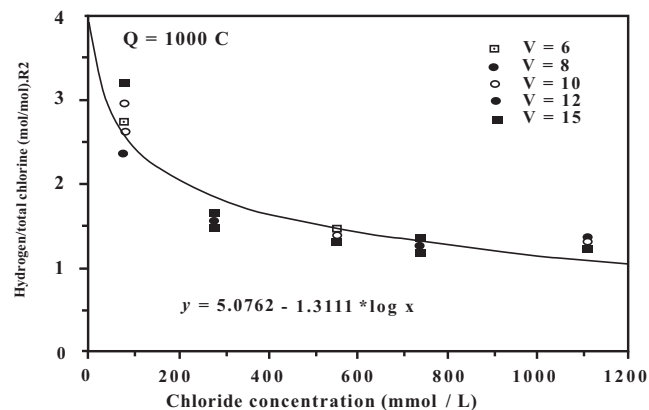

Fig. (13). Hydrogen to total chlorine vs. chloride concentration for synthetic and natural sea water at different voltages.

It shows the effect of changing the chloride concentration in sea water on the ratio of hydrogen to total chlorine, for 1000 C. At concentrations less than 600 mmol l^{-1} , there is a sharp decrease with increase in the chloride level, while at concentrations greater than 600 mmol l^{-1} , the effect is insignificant since these concentrations are high enough to avail of Cl^- ions at the anode.

CONCLUSIONS

- Hydrogen could be produced from abundant sources of sea water along with solar energy, for countries where fresh water is scarce.

- Ecological requirements, more specifically the absence of sufficient chlorine evolution in sea water electrolysis (SWE), make it a must to change the H_2/Cl_2 cell to a H_2/O_2 instead.
- In the electrolysis of chloride solutions with concentrations in the range of 4.48-62.70 gm/lit, a number of parameters are investigated including: salinity, voltage, current density, and quantity of electricity. The only major cathodic reaction is hydrogen evolution.
- Transport control of chlorides in saline solutions, hence Cl evolution, is a function of the current density. Electrolysis of sea water at low current density (less than 1 mA/cm^2) favors oxygen evolution. Accordingly, increasing the current density much greater will increase Cl_2 evolution until a value is reached at which limitation in mass transport of chlorides occur. The current density at this stage is called limiting C.D., corresponding to a value of $100\text{-}1000 \text{ mA/cm}^2$. Once this value is exceeded, Cl_2 evolution is suppressed, while O_2 is favored.
- Chlorine produced by electrolysis dissolves in solution. Once the liquid phase approaches saturation, chlorine will appear in the gas phase. Thus, both the C.D. and quantity of electricity used will influence the evolution of Cl_2 in the gas phase. Cells with almost Cl_2 -free anode gas for sea water electrolysis are possible depending on the quantity of electricity consumed as well as the cell design to ensure thorough mixing, hence more absorption of the gas in the liquid phase
- Under normal conditions of sea water electrolysis, the cell behaves as a H_2/Cl_2 rather than H_2/O_2 one. This is attributed to high over potential of O_2 at practical current densities. The most promising way for the electrolysis of sea water in a H_2/O_2 cell is the use of oxygen-selective electrodes. Oxygen reaction depends rather upon the electrode material than the chlorine reaction does and at low overpotential with different electrode materials (a porous deposit coating contain-

ing about 100 mg/m^2 manganese or MnO_2 was reported by Bennett). Thus, in the interval of a pH between 0-3, Cl_2 evolution reaction potential is lower than O_2 .

- Chlorine evolution at the anode replaces oxygen even for chloride concentrations lower than those of sea water. This shows how mass transfer and kinetics combine to make chlorine evolution the dominant anodic reaction product.

REFERENCES

- [1] Abdel-Aal, H. K.; Bassyouni, M.; Abdel, H.; Shereen, M.; Abdelkream, M. *Resources of Fossil and Non-Fossil Hydrogen in the Middle East Can Make Fuel Cells an Attractive Choice for Transportation: A Survey Study*, Paper to be presented at the WHEC, May 2010.
- [2] Gabriela E. Badea.; Caraban, A.; Cret, P.; Corbuto, I. *Water Electrolysis*, University of Oradea, Fascicle of Management and Technological Engineering, vol. VI (XVI), 2007.
- [3] de Levie, R. The electrolysis of water. *J. Electroanal. Chem.*, 2009, 476(1), 92-93.
- [4] Abdel-Aal, H. K. Water: Feedstock for Hydrogen Production. *Proceedings of the 6th WHEC*, Vienna, Austria, 1986, pp. 30-36.
- [5] Abdel-Aal, H. K.; Hussein, I. A. Electrolysis of Saline Water under Simulated Conditions of P.V. Solar Cell. *Proceeding of 9th WHEC*, Paris, 1992, pp. 439-442.
- [6] Bennett, J. E. Electrodes for generation of hydrogen and oxygen from sea water. *Int. J. Hydrogen Energy*, 1980, 4, 401-408.
- [7] Bockris, J. O.M. *Energy: The Solar Hydrogen Alternative*. Australia and New Zealand Book Co., Sydney, 1975.
- [8] Abdel-Aal, H. K.; Hussein, I. A. Parametric study for saline water electrolysis - part i: hydrogen production. *Int. J. Hydrogen Energy*, 1993, 18(6), 485-489.
- [9] Abdel-Aal, H. K.; Sultan, S. M.; Hussein, I. A. Parametric study for saline water electrolysis-part ii: chlorine evolution, selectivity and determination. *Int. J. Hydrogen Energy*, 1993, 18(7), pp. 545-551.
- [10] Hussein, I. A. M. S. Thesis. *Saline Water Electrolysis*, KFUPM, Dhahran, 1992.
- [11] Zenta Kato. Energy-Saving Seawater Electrolysis for Hydrogen Production, *Presentation: Oral at E-MRS, Symposium D*. Fall Meeting, 2007.
- [12] Kanan, M. W. *In situ* formation of an oxygen-evolving catalyst in neutral water containing phosphate and CO_3^{2-} . *Science*, 2008, 321, 1072.

Received: March 09, 2010

Revised: April 01, 2010

Accepted: April 09, 2010

© Abdel-Aal *et al.*; Licensee Bentham Open.

This is an open access article licensed under the terms of the Creative Commons Attribution Non-Commercial License (<http://creativecommons.org/licenses/by-nc/3.0/>) which permits unrestricted, non-commercial use, distribution and reproduction in any medium, provided the work is properly cited.