

Hypomagnesemia in Patients with Type 2 Diabetes

Phuong-Chi T. Pham,* Phuong-Mai T. Pham,[†] Son V. Pham,[‡] Jeffrey M. Miller,[§] and Phuong-Thu T. Pham^{||}

*Nephrology and [§]Hematology/Oncology Division, Department of Medicine, Olive View-UCLA Medical Center, Sylmar, California; [†]Department of Medicine, Maine Medical Center, Lewiston, Maine; [‡]Cardiology Division, Sacramento Veterans Administration Medical Center, Sacramento, California; ^{||}Kidney and Pancreas Transplantation, David Geffen School of Medicine at UCLA, Los Angeles, California

Hypomagnesemia has been reported to occur at an increased frequency among patients with type 2 diabetes compared with their counterparts without diabetes. Despite numerous reports linking hypomagnesemia to chronic diabetic complications, attention to this issue is poor among clinicians. This article reviews the literature on the metabolism of magnesium, incidence of hypomagnesemia in patients with type 2 diabetes, implicated contributing factors, and associated complications. Hypomagnesemia occurs at an incidence of 13.5 to 47.7% among patients with type 2 diabetes. Poor dietary intake, autonomic dysfunction, altered insulin metabolism, glomerular hyperfiltration, osmotic diuresis, recurrent metabolic acidosis, hypophosphatemia, and hypokalemia may be contributory. Hypomagnesemia has been linked to poor glycemic control, coronary artery diseases, hypertension, diabetic retinopathy, nephropathy, neuropathy, and foot ulcerations. The increased incidence of hypomagnesemia among patients with type 2 diabetes presumably is multifactorial. Because current data suggest adverse outcomes in association with hypomagnesemia, it is prudent to monitor magnesium routinely in this patient population and treat the condition whenever possible.

Clin J Am Soc Nephrol 2: 366–373, 2007. doi: 10.2215/CJN.02960906

Type 2 diabetes accounts for approximately 90 to 95% of all diagnosed cases of diabetes (1). In addition to hyperosmolar coma and ketoacidosis, patients with type 2 diabetes may have cardiovascular disease, nephropathy, retinopathy, and polyneuropathy. With its associated complications, diabetes was reported to be the sixth leading cause of death listed on US death certificates in 2000 (1). The treatment of the patients with diabetes requires a multidisciplinary approach whereby every potential complicating factor must be monitored closely and treated. In particular, although hypomagnesemia has been reported to occur with increased frequency among patients with type 2 diabetes, it is frequently overlooked and undertreated.

Magnesium and Cell Physiology

Magnesium is the fourth most abundant cation in the human body and the second most abundant intracellular cation. It may exist as a protein-bound, complexed, or free cation. It serves as a co-factor for all enzymatic reactions that require ATP and as a key component in various reactions that require kinases. It is also an essential enzyme activator for neuromuscular excitability and cell permeability, a regulator of ion channels and mitochondrial function, a critical element in cellular proliferation

and apoptosis, and an important factor in both cellular and humoral immune reactions (reviewed in references [2–6]).

Diagnosis of Hypomagnesemia

Traditionally, hypomagnesemia refers to a low serum magnesium (Mg) concentration because this measurement has long been readily available. Clinically, hypomagnesemia may be defined as a serum Mg concentration ≤ 1.6 mg/dl or >2 SD below the mean of the general population (7,8). However, because Mg is mostly an intracellular cation, it has been questioned whether one can use measurements of serum Mg concentrations to study the impact of Mg on various physiologic conditions. Some investigators, instead, have used measurements of intracellular Mg concentrations. Clinically, it has been suggested that in a patient with suspected Mg deficiency, a low serum Mg concentration is sufficient to confirm the diagnosis. If the serum Mg level is normal in the same patient, then other more sensitive tests should be performed (reviewed in references [5,9]). Although controversies still exist as to how hypomagnesemia is best gauged, our current understanding on the clinical impact of hypomagnesemia in human is influenced by studies that have relied predominantly on the measurements of serum Mg concentrations.

Incidence of Hypomagnesemia among Patients with Type 2 Diabetes

Hypomagnesemia, defined by low serum Mg concentrations, has been reported to occur in 13.5 to 47.7% of nonhospitalized patients with type 2 diabetes compared with 2.5 to 15% among

Published online ahead of print. Publication date available at www.cjasn.org.

Address correspondence to: Dr. Phuong-Chi T. Pham, Olive View-UCLA Medical Center, 14445 Olive View Drive, Department of Medicine, 2B-182, Nephrology Division, Sylmar, CA 91342. Phone: 818-364-1555, ext. 6557; Fax: 818-364-4573; E-mail: pctp@ucla.edu

their counterparts without diabetes (7,8,10–13). The wide range in the reported incidence of hypomagnesemia most likely reflects the difference in the definition of hypomagnesemia, techniques in Mg measurements, and the heterogeneity of the selected patient cohort. In terms of gender difference, it is interesting to note that independent studies have reported a higher incidence of hypomagnesemia in women compared with men, at a 2-to-1 ratio (7,14). In addition, men with diabetes may have higher ionized levels of Mg (15).

Hypomagnesemia and Diabetes: Cause and Effect

Not only has hypomagnesemia been associated with type 2 diabetes, but also numerous studies have reported an inverse relationship between glycemic control and serum Mg levels (7,10,16–19). Although many authors have suggested that diabetes *per se* may induce hypomagnesemia, others have reported that higher Mg intake may confer a lower risk for type 2 diabetes (20–23). It is interesting that the induction of Mg deficiency has been shown to reduce insulin sensitivity in individuals without diabetes, whereas Mg supplementation during a 4-wk period has been shown to improve glucose handling in elderly individuals without diabetes (18,24). In patients with type 2 diabetes, oral Mg supplementation during a 16-wk period was suggested to improve insulin sensitivity and metabolic control (25). The mechanisms whereby hypomagnesemia may induce or worsen existing diabetes are not well understood. Nonetheless, it has been suggested that hypomagnesemia may induce altered cellular glucose transport, reduced pancreatic insulin secretion, defective postreceptor insulin signaling, and/or altered insulin–insulin receptor interactions (26–29). Not all studies, however, observed a correlation between glycemic control and serum Mg levels or improvement of diabetic control with Mg replacement (11,30–32). The conflicting data may reflect different study designs and populations studied.

Hypomagnesemia and Adverse Clinical Associations in Type 2 Diabetes

Hypomagnesemia at the Cellular Level

There is considerable evidence to suggest that hypomagnesemia may adversely affect various aspects of cellular physiology. Available data suggest that low Mg levels may promote endothelial cell dysfunction and thrombogenesis *via* increased platelet aggregation and vascular calcifications (33). Low Mg levels also may lead to the induction of proinflammatory and profibrogenic response (34–36), reduction of protective enzymes against oxidative stress (37), induction or augmentation of vasoconstriction and hypertension (38–40), and stimulation of aldosterone (41,42), among others. Moreover, because Mg is crucial in DNA synthesis and repair (43), it is possible that Mg deficiency may interfere with normal cell growth and regulation of apoptosis.

Hypomagnesemia in the Clinical Setting

Clinically, there are significant data linking hypomagnesemia to various diabetic micro- and macrovascular complications.

Cardiovascular. In a study that involved 19 normotensive individuals without diabetes, 17 hypertensive individuals without diabetes, and 6 hypertensive individuals with diabetes, Resnick *et al.* (44) documented the lowest mean intracellular Mg concentration among the last group. Similarly, based on data from the Atherosclerosis Risk in Communities (ARIC) Study, a multicenter, prospective cohort study that lasted 4 to 7 yr and involved 13,922 middle-aged adults who were free of coronary heart disease at baseline, an inverse association between serum Mg and the risk for coronary heart disease was observed among men with diabetes (45).

Diabetic Retinopathy. The link between hypomagnesemia and diabetic retinopathy was reported in two cross-sectional studies that involved both “insulin-dependent” patients and patients with type 2 diabetes. Not only did patients with diabetes have lower serum Mg levels compared with their counterparts without diabetes, but also the serum Mg levels among the cohort with diabetes had an inverse correlation with the degree of retinopathy (46,47). A similar link, however, was not observed when Mg was measured within mononuclear cells. In a study that involved 128 patients with type 2 diabetes and poor glycemic control (glycosylated hemoglobin >8.0%), intramononuclear Mg concentrations were not observed to be lower among those with diabetic retinopathy but rather among those with neuropathy and coronary disease (11).

Foot Ulcerations. Given the link between hypomagnesemia and risk factors for the development of diabetic foot ulcers (*e.g.*, polyneuropathy, platelet dysfunction), Rodriguez-Moran and Guerrero-Romero (48) suggested that hypomagnesemia may be associated with an increased risk of diabetic foot ulcers. Indeed, they observed a higher incidence of hypomagnesemia among their patients with diabetic foot ulcers compared with those without the condition (93.9% of the 33 patients with diabetic foot ulcers compared with 73.1% of the 66 patients without diabetic foot ulcers; $P = 0.02$).

Nephropathy. In a comparative study that involved 30 patients who had type 2 diabetes without microalbuminuria, 30 with microalbuminuria, and 30 with overt proteinuria, Corsonello *et al.* (49) observed a significant decrease in serum ionized Mg in both the microalbuminuria and overt proteinuria groups compared with the nonmicroalbuminuric group. Accordingly, in a recent retrospective study, an association between low serum Mg levels and a significantly faster rate of renal function deterioration in patients with type 2 diabetes was reported (7).

Others. Finally, there also are data to suggest the association between hypomagnesemia and other diabetic complications, including dyslipidemia and neurologic abnormalities (6). Because hypomagnesemia has been linked to various micro- and macrovascular complications, a better understanding of Mg metabolism and efforts to minimize hypomagnesemia in the routine management of diabetes are warranted.

Normal Mg Metabolism

Gastrointestinal Metabolism

On an average American diet, 250 to 350 mg of Mg is consumed daily. Twenty-five to 60% of dietary Mg is absorbed in the gastrointestinal tract. Gastrointestinal absorption occurs predominantly in the small intestines *via* paracellular simple diffusion at high intraluminal concentrations and active transcellular uptake *via* Mg-specific transporters at low concentrations (reviewed in reference [50]). Active intestinal Mg absorption is presumed to involve transient receptor potential channel melastatin 6 (TRPM6), which is expressed along the brush border membrane of the small intestine (51). Mutations of TRPM6 have been reported to be associated with hypomagnesemia with secondary hypocalcemia (52,53).

Renal Metabolism

Glomerular Filtration. Approximately 70 to 80% of plasma Mg is ultrafilterable in the ionic form (70 to 80%) and complexed with anions such as phosphate, citrate, and oxalate (20 to 30%) (54,55). The ultrafilterability of Mg depends on glomerular filtration, volume status, various metabolic states that would enhance the selection for ionized Mg (*e.g.*, acidemia, reduced serum content of negatively charged species), and the integrity of the glomerular basement membrane.

Proximal Tubules. Once Mg is filtered through the glomerulus, 15 to 25% is reabsorbed in the proximal tubules (Figure 1). Reabsorption at the proximal tubule is mainly passive and proportional to sodium and water reabsorption, although at a lower rate (55).

Loop of Henle. Approximately 65 to 75% of the Mg filtered load is reabsorbed *via* the paracellular pathway in the thick ascending limb of the loop of Henle (TAH) (55) (Figure 1). Paracellular Mg reabsorption at this nephron segment has been suggested to be facilitated by claudin 6, also known as paracel-

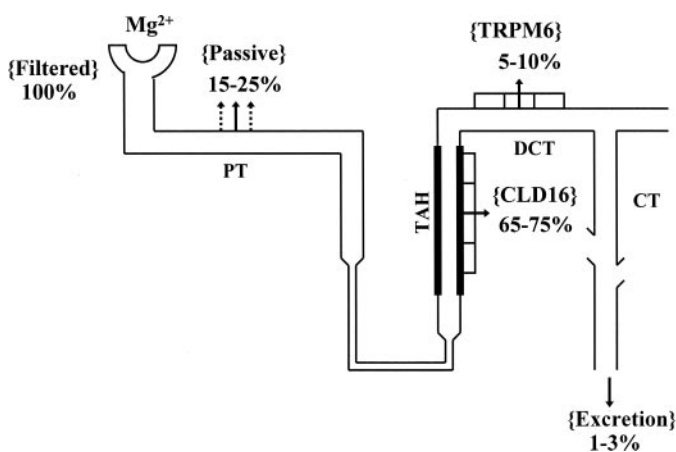

Figure 1. Renal magnesium (Mg) handling. After glomerular filtration, ionized magnesium is reabsorbed passively in parallel to sodium reabsorption at the proximal tubules (PT); paracellularly *via* claudin 6 (CLD16; paracellin 1) at the thick ascending limb of the loop of Henle (TAH); and transcellularly *via* transient receptor potential channel melastatin (TRPM6) at the distal convoluted tubule (DCT). CT, collecting tubules.

lin 1. Paracellin 1 is a tight junction protein whose mutation is associated with severe hypomagnesemia with hypercalciuria and nephrolithiasis (56,57). Parathyroid hormone, calcitonin, glucagon, and antidiuretic hormone have been suggested to enhance Mg transport in the TAL *via* the second messenger cAMP (55). Insulin also has been implicated to play a role at this nephron segment by increasing the favorable transepithelial potential difference for Mg reabsorption (58).

Distal Convuluted Tubules. The distal convoluted tubule (DCT) reabsorbs approximately 5 to 10% of the filtered Mg *via* an active and regulated transcellular pathway (Figure 1). Although this is a low percentage of the filtered Mg load, it represents 70 to 80% of Mg that is delivered from the TAL. In addition, because a negligible amount of Mg is reabsorbed distal to this segment, Mg reabsorption at the DCT is of great importance because it determines the final urinary Mg concentration (50).

Recently, Mg reabsorption at the DCT was shown to occur *via* the transient receptor potential channel melastatin TRPM6 (Figure 2) (52,53,59,60). It has been postulated that upon entry into the cells, Mg binds to divalent-binding proteins such as parvalbumin or calbindin-D28K for transport across the cell to the basolateral membrane, where Mg is taken into the interstitium by a basolateral $\text{Na}^{2+}/\text{Mg}^{2+}$ exchanger and/or ATP-dependent Mg pump (51,61–63).

It is interesting that the regulation of magnesium reabsorption at the DCT was studied extensively before the actual identification of TRPM6 (Figure 2) (62). Peptide hormones such as parathyroid hormone (PTH), calcitonin, glucagon, and vasopressin all have been implicated. The mediating mechanisms are unknown but seem to involve, in part, stimulation of cAMP release and activation of protein kinase A, phospholipase C, and protein kinase C. Insulin also has been suggested to enhance intracellular Mg uptake, presumably *via* tyrosine kinase. Moreover, insulin may stimulate the production of cAMP and

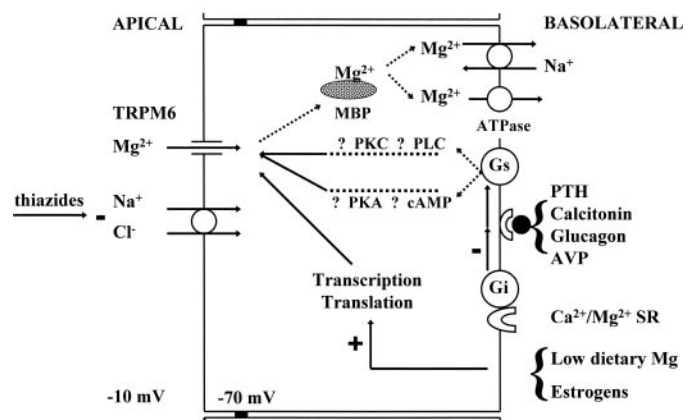

Figure 2. Regulation of Mg handling at the DCT. AVP, arginine vasopressin; $\text{Ca}^{2+}/\text{Mg}^{2+}$ SR, $\text{Ca}^{2+}/\text{Mg}^{2+}$ sensing receptor; G_i , inhibitory G protein; G_s , stimulatory G protein; MBP, Mg^{2+} -binding protein; PKA, protein kinase A; PKC, protein kinase C; PLC, phospholipase C; PTH, parathyroid hormone. Adapted from reference (62), with permission.

potentiate Mg uptake *via* other cAMP-dependent hormones, including PTH (62). In addition, the $\text{Ca}^{2+}/\text{Mg}^{2+}$ sensing receptor on the basolateral side may modulate hormone-stimulated Mg transport through G-protein coupling (62). Finally, low dietary Mg intake and estrogens have been shown to upregulate renal TRPM6 expression and reduce urinary Mg excretion (64).

Possible Causes of Hypomagnesemia in Type 2 Diabetes

Hypomagnesemia in the patient with diabetes may result from poor oral intake, poor gastrointestinal absorption, and enhanced renal Mg excretion (Table 1).

Gastrointestinal Causes

Diabetic autonomic neuropathies that may reduce oral intake and gastrointestinal absorption include esophageal dysfunction, gastroparesis, and diarrhea (65). Whether gastrointestinal Mg absorption *via* TRPM6 is reduced in the patient with diabetes is not known.

Renal Causes

Enhanced Filtered Load. In the patient with diabetes, the ultrafilterable Mg load may be enhanced by glomerular hyperfiltration, recurrent excessive volume repletion after hyperglycemia-induced osmotic diuresis, recurrent metabolic acidosis associated with diabetic ketoacidosis, and hypoalbuminemia (50). The last two conditions may increase the serum ionized Mg fraction and, hence, ultrafilterable Mg load and subsequent

Table 1. Possible causes of hypomagnesemia in patients with type 2 diabetes

Decreased intake
poor oral intake
esophageal dysfunction
diabetic gastroparesis
Enhanced gastrointestinal loss
diarrhea as a result of autonomic dysfunction
Enhanced renal magnesium loss
enhanced filtered load
glomerular hyperfiltration
osmotic diuresis (glucosuria)
volume expansion as a result of excessive volume replacement
metabolic acidosis (diabetic ketoacidosis)
hypoalbuminemia
microalbuminuria and overt proteinuria
reduced renal reabsorption
endocrinologic dysfunction: insulin deficiency or resistance
metabolic acidosis (diabetic ketoacidosis)
electrolyte abnormalities: phosphate and potassium depletion
diuretics
others

urinary loss. In addition, it is conceivable that significant microalbuminuria and overt proteinuria among patients with diabetic nephropathy may contribute to renal Mg wasting as a result of protein-bound magnesium loss.

Enhanced Tubular Flow. Overly aggressive volume re-expansion and glomerular hyperfiltration also may induce renal Mg wasting at the proximal tubule and TAL, independent of the filtered load. Because Mg reabsorption parallels sodium reabsorption in the proximal tubules, volume expansion can decrease both sodium and Mg reabsorption at this level. Similarly, a high tubular flow through the TAL may reduce Mg reabsorption at this segment (50).

Reduced Tubular Reabsorption. Because insulin has been implicated in enhancing Mg reabsorption at the TAL, insulin deficiency or resistance in the diabetic state can promote Mg wasting at this nephron segment (58). The expression of paracellin 1 in TAL, however, has not been shown to be increased in diabetic rats (66).

In the same diabetic rat model, Lee *et al.* (66) revealed that TRPM6 expression in the DCT is not reduced but rather enhanced. This is thought to be a compensatory mechanism for the increased Mg load that is delivered to the DCT or blunted activity of the TRPM6 channel in the diabetic state. Accordingly, despite the increase in TRPM6 expression, overall renal Mg wasting is observed.

Metabolic Disturbances

Various metabolic disturbances that are associated with diabetes also have been suggested to promote urinary Mg excretion (67–69).

Hypokalemia. At the TAL segment, hypokalemia may reduce $\text{Na}^+-\text{K}^+-2\text{Cl}^-$ co-transport activity, the associated potassium extrusion through the potassium channel ROMK, and resultant diminution of the favorable transmembrane voltage that is required for paracellular Mg reabsorption. In addition, there is evidence to suggest that cellular potassium depletion may diminish Mg reabsorption at the DCT by yet unclear mechanisms (67).

Hypophosphatemia. Both micropuncture studies in phosphate-depleted dogs and *in vitro* studies involving phosphate-depleted mouse DCT cells have demonstrated reduced Mg uptake (68,69). Phosphate-induced reduction in cellular uptake of Mg is believed to be a posttranslational effect because the alteration in Mg uptake could be observed within 30 min of phosphate depletion.

Metabolic Acidosis. In addition to its role in increasing serum ionized Mg concentration and, hence, ultrafilterable Mg load for renal excretion, metabolic acidosis has been suggested to enhance protonation of the Mg channel in the DCT and subsequent inhibition of cellular Mg uptake (70). More recently, Nijenhuis *et al.* showed (71) reduced expression of TRPM6 with induced chronic metabolic acidosis in mice.

Insulin Deficiency and/or Resistance. As previously discussed, insulin deficiency or resistance may exacerbate renal Mg wasting because insulin has been shown to have antimagnesiuric effects in both the TAL and the DCT (55,62).

Use of Diuretics

The common use of diuretics among patients with diabetes also may contribute to magnesiuria. The degree of magnesiuria is traditionally thought to be lower for thiazides compared with loop diuretics (72–74). This difference has been explained by the site of action of the two types of diuretics because a smaller amount of intraluminal Mg is available for wasting at the DCT compared with that at the loop of Henle. In addition, inhibition of the Na⁺-Cl⁻ co-transporter by thiazides has been suggested to induce hyperpolarization of the DCT plasma membrane and, hence, a more favorable transmembrane electrical gradient for Mg reabsorption (67,75).

Despite these theoretical advantages of thiazides over loop diuretics, severe hypomagnesemia is observed more frequently with Gitelman's compared with Bartter's syndrome, two syndromes that have traditionally been equated to the administration of thiazides and furosemide, respectively. Recently, in support of this observation, reduced TRPM6 expression and enhanced magnesiuria were shown in mice given chronic thiazide therapy (76). Given these observations and the lack of good direct comparative data between the two classes of diuretics, it must be assumed that significant magnesiuria may occur with either.

Others

Finally, the more common use of antibiotics and antifungals such as aminoglycosides and amphotericin in patients with diabetes may also contribute to renal Mg wasting (77).

Management of Hypomagnesemia in Type 2 Diabetes

Because the literature suggests adverse outcomes in association with hypomagnesemia in patients with type 2 diabetes, measures to minimize this abnormality are warranted (Table 2).

Optimization of Gastrointestinal Absorption

Dietary Mg intake may be optimized with the help of a nutritionist. Poor dietary intake as a result of gastrointestinal autonomic dysfunction must be controlled. Lifestyle modification such as eating multiple small meals at a time instead of two or three large meals a day; tight glucose control; and the use of prokinetic medications such as metoclopramide, domperidone, or erythromycin to improve gastric motility are indicated in patients with diabetic gastroparesis associated with erratic blood sugar control (65). In intractable cases, pyloric botulinum toxin injection, enteric feeding, and gastric pacing may be explored (78–80). For those with severe and intermittent diarrhea alternating with constipation, a trial of soluble fiber, gluten and lactose restriction, and regular efforts to move the bowels are recommended. Other measures including cholestyramine, clonidine, somatostatin analog, supplemental pancreatic enzyme, and antibiotics such as metronidazole have been suggested (65).

Table 2. Suggested management of hypomagnesemia in patients with type 2 diabetes

Increase Mg intake
dietary consult
high Mg-containing food types
soy products, legumes, and seeds such as almonds and cashews, whole grains, and fruits and vegetables such as spinach, okra, Swiss chard, dried apricots, and avocados
Control of diabetic gastroparesis
eat multiple small meals instead of two to three large meals per day
tight glucose control
use of prokinetic medications to enhance gastric motility
others: pyloric botulinum toxin injection, enteric feeding, gastric pacing
Oral Mg supplementation
see Table 3
Decrease gastrointestinal loss (diarrhea)
trial of soluble fiber
regular effort to move bowels
trials of gluten-free diet, lactose restriction
others: cholestyramine, clonidine, somatostatin analog, supplemental pancreatic enzyme, and antibiotics such as metronidazole
Decrease renal Mg loss
decrease filtered load
use angiotensin-converting enzyme and/or angiotensin receptor blockers
tight glyceemic control
avoid excessive volume replacement during periods of hyperglycemia
Increase renal reabsorption
tight glyceemic control; measures to decrease insulin resistance (exercise)
replacement of phosphate and potassium as needed
replacement of diuretic-induced magnesiuria (based on a 24-h urine collection)

Table 3. Common Mg salts used as oral supplements in the United States

Mg Salt	Elemental Mg (mg)	Comments
Chloride	64	Slow-Mag, ^a Purdue ^b : contains calcium
Citrate	100	Active Calcium, ^a Usana ^b : contains calcium, vitamins D ₃ and K
Gluconate	27/tablet 54/5 ml	Magonate, ^a Fleming ^b : contains calcium and phosphorus
Oxide	241 362	MagOx400, ^a Blaine ^b : no added products Beelith, ^a Beach ^b : contains pyridoxine

^aBrand name.^bManufacturer/pharmaceutical company.

Minimization of Renal Mg Wasting

Tight glycemic control is recommended to minimize recurring renal Mg wasting in association with osmotic diuresis and metabolic acidosis. Excessive volume replacement after hyperglycemia-induced osmotic diuresis should be avoided. Associated hypophosphatemia and hypokalemia must be corrected. When indicated, a 24-h urinary Mg measurement may be considered to assess diuretic-induced renal Mg wasting and replacement. Finally, control of glomerular hyperfiltration with angiotensin-converting enzyme inhibitors or angiotensin receptor blockers or both may offer additional benefits in reducing renal Mg wasting. When hypomagnesemia persists despite all measures, oral Mg supplementation is indicated (Table 3).

Target Serum Mg Levels

Although no study has ever documented an optimal serum Mg concentration in patients with diabetes, we speculate that a level between 2.0 and 2.5 mg/dl may be favorable. Our suggestion is based on our previous findings that patients who had serum Mg levels within this range had the least degree of renal function deterioration and best glycemic control (7). Although the correction of low serum Mg levels has never been proved to be protective against chronic diabetic complications, intervention is justified because hypomagnesemia has been linked to many adverse clinical outcomes but, to our knowledge, *never* physiologic benefits. In addition, Mg supplementation is inexpensive and, with the exception of diarrhea, a relatively benign medication. Nonetheless, close observation must be given to those with renal insufficiency.

Conclusions

Hypomagnesemia, defined herein as having low serum magnesium concentrations, is common among patients with type 2 diabetes. Contributory mechanisms most likely are multifactorial. Because available data suggest that adverse outcomes are associated with hypomagnesemia, it is prudent that routine surveillance for hypomagnesemia be done and the condition be treated whenever possible.

Disclosures

None.

References

- American Diabetes Association: National Diabetes Fact Sheet, Alexandria, VA, ADA, 2002. Available at: <http://www.diabetes.org/diabetes-statistics>. Accessed February 21, 2005
- Sanders GT, Huijgen HJ, Sanders R: Magnesium in disease: A review with special emphasis on the serum ionized magnesium. *Clin Chem Lab Med* 37: 1011–1033, 1999
- Saris NEL, Mervaala E, Karppanen H, Khawaja JA, Lewenstam A: Magnesium: An update on physiological, clinical and analytical aspects. *Clin Chem Acta* 294: 1–26, 2000
- Elamin A, Tuvemo T: Magnesium and insulin-dependent diabetes mellitus. *Diabetes Res Clin Pract* 10: 203–209, 1990
- White JR, Campbell RK: Magnesium and diabetes: A review. *Ann Pharmacother* 27: 775–780, 1993
- Sales CR, de Fatima Campos Pedrosa L: Magnesium and diabetes mellitus: Their relation. *Clin Nutr* 25: 554–562, 2006
- Pham PC, Pham PM, Pham PA, Pham SV, Pham HV, Miller JM, Yanagawa N, Pham PT: Lower serum magnesium levels are associated with more rapid decline of renal function in patients with diabetes mellitus type 2. *Clin Nephrol* 63: 429–436, 2005 [published erratum appears in *Clin Nephrol* 64: 248, 2005]
- McNair P, Christensen MS, Christiansen C, Madsbad S, Transbol I: Renal hypomagnesaemia in human diabetes mellitus: Its relation to glucose homeostasis. *Eur J Clin Invest* 12: 81–85, 1982
- Tosiello L: Hypomagnesemia and diabetes mellitus. *Arch Intern Med* 156: 1143–1148, 1996
- Mather H, Nisbet JA, Burton GH, Poston GJ, Bland JM, Bailey PA, Pilkington TR: Hypomagnesemia in diabetes. *Clin Chim Acta* 95: 235–242, 1979
- De Lordes Lima M, Cruz T, Pousada JC, Rodrigues LE, Barbosa K, Cangucu V: The effect of magnesium supplementation in increasing doses on the control of type 2 diabetes. *Diabetes Care* 21: 682–686, 1998
- Walti MK, Zimmermann MB, Spinass GA, Hurrell RF: Low plasma magnesium in type 2 diabetes. *Swiss Med Wkly* 133: 289–292, 2003
- Ma J, Folsom AR, Melnick SL, Eckfeldt JH, Sharrett AR, Nabulsi AA, Hutchinson RG, Metcalf PA: Associations of serum and dietary magnesium with cardiovascular disease, hypertension, diabetes, insulin, and carotid arterial wall thickness: The ARIC study. Atherosclerosis Risk in Communities Study. *J Clin Epidemiol* 48: 927–940, 1995

14. Sheehan JP: Magnesium deficiency and diabetes mellitus. *Magnes Trace Element* 10: 215–219, 1991–1992
15. Mikhail N, Ehsanipoor K: Ionized serum magnesium in type 2 diabetes mellitus: Its correlation with serum magnesium and hemoglobin A1C levels. *South Med J* 92: 1162–1166, 1999
16. Sjogren AS, Floren CH, Nilsson A: Magnesium deficiency in IDDM related to level of glycosylated hemoglobin. *Diabetes* 35: 459–463, 1986
17. Pon KK, Ho PWM: Subclinical hyponatremia, hyperkalemia and hypomagnesemia in patients with poorly controlled diabetes mellitus. *Diabetes Res Clin Pract* 7: 163–167, 1989
18. Paolisso G, Sgambato S, Gambardella A, Pizza G, Tesaro P, Varricchio M, D'Onofrio F: Daily magnesium supplements improve glucose handling in elderly subjects. *Am J Clin Nutr* 55: 1161–1167, 1992
19. Resnick L, Altura BT, Gupta RK, Laragh JH, Alderman MH, Altura BM: Intracellular and extracellular magnesium depletion in type 2 (non-insulin-independent) diabetes mellitus. *Diabetologia* 36: 767–770, 1993
20. Kao WH, Folsom AR, Nieto J, Mo JP, Watson RL, Brancati FL: Serum and dietary magnesium and the risk for type 2 diabetes mellitus. The Atherosclerosis Risk in Communities study. *Arch Intern Med* 159: 2151–2159, 1999
21. Lopez-Ridaura R, Willett WC, Rimm EB, Liu S, Stampfer MJ, Manson JE, Hu FB: Magnesium intake and risk of type 2 diabetes in men and women. *Diabetes Care* 27: 134–140, 2004
22. Song Y, Manson JE, Buring JE, Liu S: Dietary magnesium intake in relation to plasma insulin levels and risk of type 2 diabetes in women. *Diabetes Care* 27: 59–65, 2004
23. van Dam RM, Hu FB, Rosenberg L, Krishnan S, Palmer JR: Dietary calcium and magnesium, major food sources, and risk of type 2 diabetes in US black women. *Diabetes Care* 29: 2238–2243, 2006
24. Nadler J, Buchanan T, Natarajan R, Antoipillai I, Bergman R, Rude R: Magnesium deficiency produces insulin resistance and increased thromboxane synthesis. *Hypertension* 21: 1024–1029, 1993
25. Rodriguez-Moran M, Guerrero-Romero F: Oral magnesium supplementation improves insulin sensitivity and metabolic control in type 2 diabetic subjects. *Diabetes Care* 26: 1147–1152, 2003
26. Dzurik R, Stetikova K, Spustova V, Fetkowska N: The role of magnesium deficiency in insulin resistance: An in vitro study. *J Hypertens* 9[Suppl 6]: S312–S313, 1991
27. Grafton G, Baxter MA: The role of magnesium in diabetes mellitus. *J Diabetes Complications* 6: 143–149, 1992
28. Durlach J, Altura B, Altura BM: Highlights and summary of the 10th annual French Colloquium on Magnesium. *Magnesium* 2: 330–336, 1983
29. Tonyai S, Motto C, Rayssiguier Y, Heaton FW: Erythrocyte membrane in magnesium deficiency [Abstract]. *Am J Nutr* 4: 399, 1985
30. Garber AJ: Magnesium utilization survey in selected patients with diabetes. *Clin Ther* 18: 285–294, 1996
31. Schnack C, Bauer I, Pregant P, Hopmeier P, Schernthaner G: Hypomagnesemia in type 2 diabetes mellitus is not corrected by improvement of long term control. *Diabetologia* 35: 77–79, 1992
32. Eibl NL, Koppe HP, Nowak HR, Schnack CJ, Hopmeier PG, Schernthaner G: Hypomagnesemia in type 2 diabetes: Effect of a 3-month replacement therapy. *Diabetes Care* 18: 188–192, 1995
33. Rayssiguier Y: Role of magnesium and potassium in the pathogenesis of arteriosclerosis. *Magnesium* 3: 226–238, 1984
34. Shivakumar K: Pro-fibrogenic effects of magnesium deficiency in the cardiovascular system. *Magnes Res* 15: 307–315, 2002
35. Kurantsin-Mills J, Cassidy MM, Stafford RE, Weglicki WB: Marked alterations in circulating inflammatory cells during cardiomyopathy development in a magnesium-deficient rat model. *Br J Nutr* 78: 845–855, 1997
36. Maier JAM, Malpuech-Brugere C, Zimowska W, Raysiguier Y, Mazur A: Low magnesium promotes endothelial cell dysfunction: Implications for atherosclerosis, inflammation and thrombosis. *Biochim Biophys Acta* 1689: 13–21, 2004
37. Zhou Q, Olinescu RM, Kummerow FA: Influence of low magnesium concentrations in the medium on the antioxidant system in cultured human arterial endothelial cells. *Magnes Res* 12: 19–29, 1999
38. Chakraborti S, Chakraborti T, Mandal M, Mandal A, Das S, Ghosh S: Protective role of magnesium in cardiovascular diseases: A review. *Mol Cell Biochem* 238: 163–179, 2002
39. Altura BM, Altura BT, Gehrewold A, Ising H, Gunther T: Magnesium deficiency and hypertension: Correlation between magnesium-deficient diets and microcirculatory changes in situ. *Science* 223: 1315, 1984
40. Rude R, Manoogian C, Ehrlich L, De Russo PD, Ryzen E, Nadler J: Mechanisms of blood pressure regulation by magnesium in man. *Magnesium* 8: 266, 1989
41. Fakunding JL, Chow R, Catt KJ: The role of calcium in the stimulation of aldosterone production by adrenocorticotropin, angiotensin II, and potassium in isolated glomerulosa cells. *Endocrinology* 105: 327–333, 1979
42. Ichihara A, Suzuki H, Saruta T: Effects of magnesium on the renin-angiotensin-aldosterone system in human subjects. *J Lab Clin Med* 122: 432–440, 1993
43. Hartwig A: Role of magnesium in genomic stability. *Mutat Res* 475: 113–121, 2001
44. Resnick LM, Gupta RK, Gruenspan H, Laragh JH: Intracellular free magnesium in hypertension: Relation to peripheral insulin resistance. *J Hypertens* 6[Suppl 4]: s199–s201, 1988
45. Liao F, Folsom AR, Brancati FL: Is low magnesium concentration a risk factor for coronary heart disease? The Atherosclerosis Risk in Communities (ARIC) Study. *Am Heart J* 136: 480–490, 1998
46. McNair P, Christiansen C, Modibad S, Binder C: Hypomagnesemia, a risk factor in diabetic retinopathy. *Diabetes* 27: 1075–1077, 1978
47. Hatwal A, Gujral AS, Bhatia RPS, Agrawal JK, Bajpai HS: Association of hypomagnesemia with diabetic retinopathy. *Acta Ophthalmol* 67: 714–716, 1989
48. Rodriguez-Moran M, Guerrero-Romero F: Low serum magnesium levels and foot ulcers in subjects with type 2 diabetes. *Arch Med Res* 32: 300–303, 2001
49. Corsonello A, Lentile R, Buemi M, Cucinotta D, Mauro VN, Macaione S, Corica F: Serum ionized magnesium levels in type 2 diabetic patients with microalbuminuria or clinical proteinuria. *Am J Nephrol* 20: 187–192, 2000

50. Quamme GA: Renal handling of magnesium. In: *Massry and Glasscock's Textbook of Nephrology*, 4th Ed., edited by Massry SH, Glasscock RJ, Baltimore, Lippincott Williams & Wilkins, 2001, pp 344–350
51. Voets T, Nilius B, Hoefs S, van der Kemp AW, Droogmans G, Bindels RJ, Hoenderop JG: TRPM6 forms the Mg²⁺ influx channel involved in intestinal and renal Mg²⁺ absorption. *J Biol Chem* 279: 19–25, 2004
52. Schlingmann KP, Weber S, Peters M, Niemann Nejsum L, Vitzthum H, Klingel K, Kratz M, Haddad E, Ristoff E, Dinour D, Syrrou M, Nielsen S, Sassen M, Waldegger S, Seyberth HW, Konrad M: Hypomagnesemia with secondary hypocalcemia is caused by mutations in TRPM6, a new member of the TRPM gene family. *Nat Genet* 31: 166–170, 2002
53. Walder RY, Landau D, Meyer P, Shalev H, Tsolia M, Borochowitz Z, Boettger MB, Beck GE, Englehardt RK, Carmi R, Sheffield VC: Mutation of TRPM6 causes familial hypomagnesemia with secondary hypocalcemia. *Nat Genet* 31: 171–174, 2002
54. Quamme GA, Dirks JH: The physiology of renal magnesium handling. *Ren Physiol* 9: 257, 1986
55. Quamme GA: Control of magnesium transport in the thick ascending limb. *Am J Physiol* 256: F197–F210, 1989
56. Simon DB, Lu Y, Choate KA, Velazquez H, Al-Sabban E, Praga M, Casari G, Bettinelli A, Colussi G, Rodriguez-Soriano J, McCredie D, Milford D, Sanjad S, Lifton RP: Paracellin-1, a renal tight junction protein required for paracellular Mg²⁺ resorption. *Science* 285: 103–106, 1999
57. Weber S, Hoffmann K, Jeck N, Saar K, Boeswald M, Kuwertz-Broeking E, Meij II, Knoers NV, Cochat P, Sulakova T, Bonzel KE, Soergel M, Manz F, Schaerer K, Seyberth HW, Reis A, Konrad M: Familial hypomagnesaemia with hypercalciuria and nephrocalcinosis maps to chromosome 3q27 and is associated with mutations in the PCLN-1 gene. *Eur J Hum Genet* 8: 414–422, 2000
58. Mandon B, Siga E, Chabardes D, Firsov D, Roinel N, De Rouffignac C: Insulin stimulates Na⁺, Cl⁻, Ca²⁺ and Mg²⁺ transports in TAL of mouse nephron: Cross-potential with AVP. *Am J Physiol* 265: F361–F369, 1993
59. Nadler MJ, Hermosura MC, Inabe K, Perraud AL, Zhu Q, Stokes AJ, Kurosaki T, Kinet JP, Penner R, Scharenberg AM, Fleig A: LTRPC7 is a Mg²⁺-ATP-regulated divalent cation channel required for cell viability. *Nature* 411: 590–595, 2001
60. Monteilh-Zoller MK, Hermosura MC, Nadler MJ, Scharenberg AM, Penner R, Fleig A: TRPM7 provides an ion channel mechanism for cellular entry of trace metal ions. *J Gen Physiol* 121: 49–60, 2003
61. Quamme GA: Renal magnesium handling: New insights into old problems. *Kidney Int* 52: 1180–1195, 1997
62. Dai LJ, Ritchie G, Kerstan D, Kang HS, Cole DEC, Quamme GA: Magnesium transport in the renal distal convoluted tubule. *Physiol Rev* 81: 51–81, 2001
63. Quamme GA, Dai LJ: Presence of a novel influx pathway for Mg²⁺ in MDCK cells. *Am J Physiol* 259: C521–C525, 1990
64. Groenesteghe WM, Hoenderop JG, van den Heuvel L, Knoers N, Bindels RJ: The epithelial Mg²⁺ channel transient receptor potential melastatin 6 is regulated by dietary Mg²⁺ content and estrogens. *J Am Soc Nephrol* 17: 1035–1043, 2006
65. Boulton AJ, Vinik AI, Arezzo JC, Bril V, Feldman EL, Freeman R, Malik RA, Maser RE, Sosenko JM, Ziegler D: American Diabetes Association. Diabetic neuropathies: A statement by the American Diabetes Association. *Diabetes Care* 28: 956–962, 2005
66. Lee C-T, Lien Y-HH, Lai L-W, Chen J-B, Lin C-R, Chen H-C: Increased renal calcium and magnesium transporter abundance in streptozotocin-induced diabetes mellitus. *Kidney Int* 69: 1786–1791, 2006
67. Dai LJ, Friedman PA, Quamme GA: Cellular mechanisms of chlorothiazide and potassium depletion on Mg²⁺ uptake in mouse distal convoluted tubule cells. *Kidney Int* 51: 1008–1017, 1997
68. Dai LJ, Friedman PA, Quamme GA: Phosphate depletion diminishes Mg²⁺ uptake in mouse distal convoluted tubule cells. *Kidney Int* 51: 1710–1718, 1997
69. Wong NLM, Quamme GA, O'Callaghan TJ, Sutton RAL, Dirks JH: Renal and tubular transport in phosphate depletion: A micropuncture study. *Can J Physiol Pharmacol* 58: 1063–1071, 1980
70. Dai LJ, Friedman PA, Quamme GA: Acid-base changes alter Mg²⁺ uptake in mouse distal convoluted tubule cells. *Am J Physiol Renal Physiol* 272: F759–F766, 1997
71. Nijenhuis T, Renkema KY, Hoenderop JG, Bindels RJ: Acid-base status determines the renal expression of Ca²⁺ and Mg²⁺ transport proteins. *J Am Soc Nephrol* 17: 617–626, 2006
72. Duarte CG: Effects of chlorothiazide and amipramizide (MK 870) on the renal excretion of calcium, phosphate and magnesium. *Metabolism* 17: 420–429, 1968
73. Eknoyan G, Suki WN, Martinez-Maldonado M: Effect of diuretics on urinary excretion of phosphate, calcium, and magnesium in thyroparathyroidectomized dogs. *J Lab Clin Med* 76: 257–266, 1970
74. Hodler J, Roulin F, Haldimann B: Short-term effect of thiazides on magnesium and calcium metabolism and secondarily on that of phosphorus, uric acid, oxalate and cyclic AMP [in French]. *Nephrologie* 4: 60–63, 1983
75. Dai LJ, Raymond L, Friedman PA, Quamme GA: Mechanisms of amiloride stimulation of Mg²⁺ uptake in immortalized mouse distal convoluted tubule cells. *Am J Physiol Renal Physiol* 272: F249–F256, 1997
76. Nijenhuis T, Vallon V, van der Kemp AW, Loffing J, Hoenderop JG, Bindels RJ: Enhanced passive Ca²⁺ reabsorption and reduced Mg²⁺ channel abundance explains thiazide-induced hypocalciuria and hypomagnesemia. *J Clin Invest* 115: 1651–1658, 2005
77. Tong GM, Rude RK: Magnesium deficiency in critical illness. *J Intensive Care Med* 20: 3–17, 2005
78. O'Donovan D, Feinle-Bisset C, Jones K, Horowitz M: Idiopathic and diabetic gastroparesis. *Curr Treat Options Gastroenterol* 6: 299–309, 2003
79. Smith DS, Ferris CD: Current concepts in diabetic gastroparesis. *Drugs* 63: 1339–1358, 2003
80. Bromer MQ, Friedenberf F, Miller LS, Fisher RS, Swartz K, Parkman HP: Endoscopic pyloric injection of botulinum toxin A for the treatment of refractory gastroparesis. *Gastrointest Endosc* 61: 833–839, 2005