

# Hypoxia-Inducible Factor-1 (HIF-1) Up-Regulates Adrenomedullin Expression in Human Tumor Cell Lines during Oxygen Deprivation: A Possible Promotion Mechanism of Carcinogenesis

Mercedes Garayoa, Alfredo Martínez, Sunmin Lee, Rubén Pío,  
Won G. An, Len Neckers, Jane Trepel, Luis M. Montuenga,  
Heather Ryan, Randall Johnson, Max Gassmann, and  
Frank Cuttitta

Department of Cell and Cancer Biology (M.G., A.M., S.L., R.P.,  
W.G.A., L.N., J.T., F.C.)  
National Cancer Institute  
National Institutes of Health  
Bethesda, Maryland 20892

Department of Histology and Pathology (L.M.M.)  
University of Navarra  
31080 Pamplona, Spain

Department of Biology (H.R., R.J.)  
University of California San Diego  
La Jolla, California 92093

Institute of Physiology (M.G.)  
University of Zürich-Irchel  
CH-8057, Switzerland

Little is known about the molecular mechanisms that control adrenomedullin (AM) production in human cancers. We demonstrate here that the expression of AM mRNA in a variety of human tumor cell lines is highly induced in a time-dependent manner by reduced oxygen tension (1% O<sub>2</sub>) or exposure to hypoxia mimetics such as desferrioxamine mesylate (DFX) or CoCl<sub>2</sub>. This AM expression seems to be under hypoxia-inducible factor-1 (HIF-1) transcriptional regulation, since HIF-1 $\alpha$  and HIF-1 $\beta$  knockout mouse cell lines had an ablated or greatly reduced hypoxia AM mRNA induction. Similarly, inhibition or enhancement of HIF-1 activity in human tumor cells showed an analogous modulation of AM mRNA. Under hypoxic conditions, immunohistochemical analysis of tumor cell lines revealed elevated levels of AM and HIF-1 $\alpha$  as compared with normoxia, and we also found an increase of immunoreactive AM in the conditioned medium of tumor cells analyzed by RIA. AM mRNA

stabilization was shown to be partially responsible for the hypoxic up-regulated expression of AM. In addition, we have identified several putative hypoxia response elements (HREs) in the human AM gene, and reporter studies with selected HREs were capable of enhancing luciferase expression after exposure to DFX. Furthermore, transient co-expression of HIF-1 $\alpha$  resulted in an augmented transactivation of the reporter gene after DFX treatment. Given that most solid human tumors have focal hypoxic areas and that AM functions as a mitogen, angiogenic factor, and apoptosis-survival factor, our findings implicate the HIF-1/AM link as a possible promotion mechanism of carcinogenesis. (*Molecular Endocrinology* 14:848–862, 2000)

## INTRODUCTION

Adrenomedullin (AM) is a recently discovered hypotensive peptide isolated from a human pheochromocytoma (1). The cDNAs for human, rat, mouse, pig, and cow AM have been cloned and the genomic organi-

zation profile for human and mouse identified (2, 3). This peptide has been shown to mediate a multifunctional response in cell culture and animal systems that includes regulation of cardiovascular tone, bronchodilation, modulation of central brain function, natriuretic and diuretic action, antimicrobial activity, inhibition of hormone release, growth regulation, apoptosis survival, and induction of angiogenesis (see review in Refs. 4–6).

Several prior reports have demonstrated AM and its corresponding receptor (AM-R) to be ubiquitously expressed during embryogenesis and carcinogenesis. Early in both mouse and rat fetal development AM/AM-R are first detected in the heart, and then they appear progressively in other anatomical sites during organogenesis (7, 8). Maternal decidual cells and embryonic cells (fetal cytotrophoblast giant cells) of the ectoplacental cone, a site that mimics the invasion process of carcinogenesis, also show abundant expression of AM/AM-R (8, 9). After its initial identification in a human pheochromocytoma, further studies have demonstrated increased AM expression in tumor tissue of ganglioneuroblastoma, neuroblastoma, and adrenocortical carcinomas (10, 11). In addition, AM plasma levels are elevated in patients with gastrointestinal or lung cancer (12). Our group has shown that AM and AM-R are expressed in human tumor cell lines of the lung, breast, colon, ovary, prostate, brain, cartilage, and blood (13). In several of these lines, AM functioned as an autocrine proliferation factor whose effect could be inhibited by a neutralizing monoclonal antibody (MoAb-G6) causing growth cessation *in vitro* (13). Recently, it has been shown that hypoxic conditions or exposure to  $\text{CoCl}_2$  (a transition metal that mimics hypoxia) induces an increase in AM mRNA expression and protein production in a human colorectal carcinoma cell line, DLD-1 (14).

Focal areas of low oxygen tension ( $\leq 2.0\% \text{ O}_2$ ) are inherent to the biological processes of embryogenesis, wound repair, and carcinogenesis (15–17). A state of diminished free oxygen availability results when regional growth demands exceed the oxygen supply of the capillary bed (15). Under such conditions, an oxygen-sensing mechanism activates a transcription factor known as hypoxia-inducible factor-1 (HIF-1), which in turn up-regulates a series of genes that support the cell to compensate for the potentially lethal microenvironment (18). HIF-1 is a heterodimer composed of HIF-1 $\alpha$  and HIF-1 $\beta$ /ARNT (aryl hydrocarbon receptor nuclear translocator) subunits, both representing members of the PAS (Per, ARNT, Sim) basic-helix-loop-helix family (18). Transcription/translation products of HIF-1 $\alpha$  and HIF-1 $\beta$  are constitutively expressed; however, the HIF-1 $\alpha$  protein contains an oxygen-dependent degradation domain that is rapidly cleaved by the ubiquitin-proteasome pathway under normoxic conditions, thus enabling the modulation of HIF-1 activity in an oxygen-dependent manner (19). Genes transactivated by HIF-1 include aldolase A, enolase 1, erythropoietin (Epo), glucose transporter 1,

heme oxygenase 1, inducible nitric oxide synthase, lactate dehydrogenase A, phosphofructokinase L, phosphoglycerate kinase 1, transferrin (Tf), vascular endothelial growth factor (VEGF), and endothelin-1 (ET-1) (18, 20). Low oxygen tension is known to play a critical role in embryonic development, causes the emergence of drug/radiation-resistant tumor cells, enhances mutagenesis of neoplastic lesions, and elevates metastatic potential of the tumor (15, 21–24).

The way AM gene expression is regulated in human tumors is not yet known, but a decrease in oxygen tension could be a major cause for the induction of this molecule. In our present study we actually demonstrate the ability of hypoxia and hypoxia mimetics to up-regulate the AM message and protein expression in a variety of human tumor cell lines. We also made use of both molecular and biochemical characterization approaches to support that this induction is mediated by transactivation of the AM promoter by HIF-1 transcription factor as well as posttranscriptional mRNA stabilization.

## RESULTS

### AM mRNA Induction in Human Tumor Cell Lines under Hypoxic Treatments

Northern analysis for AM mRNA expression in a variety of human tumor cell lines (cancers of the lung, breast, colon, ovary, prostate, bone, and blood) demonstrated a consistent increase in message induced by exposure to 1%  $\text{O}_2$ , desferrioxamine (DFX), or  $\text{CoCl}_2$ . All 17 cell lines evaluated in this manner showed inducible AM expression, and Fig. 1 illustrates a representative example of the observed responses to our test conditions (6 h exposure to 100  $\mu\text{M}$   $\text{CoCl}_2$ , 6 h exposure to 260  $\mu\text{M}$  DFX or 12 h exposure to 1%  $\text{O}_2$ ). Interestingly, although there is variability of expression in the basal AM mRNA levels between cell lines [the two pulmonary cancer cell lines NCI-H1264 (adenocarcinoma) and NCI-H157 (squamous cell carcinoma) being the opposing extremes], all tumor cell lines show increases in AM message expression on exposure to our hypoxic test conditions, with calculated test/basal ratios ranging from 1.3- to 25-fold.

We have used MCF7 (breast adenocarcinoma) as our standard human cancer cell line for all time course studies with exposures to  $\text{CoCl}_2$ , DFX, or 1%  $\text{O}_2$ . Figure 2, A–C, demonstrates the induction of AM message at different time increments over a 24–48 h exposure series. Note that although  $\text{CoCl}_2$  exposure causes AM mRNA levels to reach a maximum at 8 h, both DFX and 1%  $\text{O}_2$  induced an AM message zenith at 12 h, indicating a potential mechanistic difference between test reagents. Induced maximum levels of AM message are maintained with all the hypoxia treatments tested at 24 h of exposure, and even elevated levels are still observed at 48 h of exposure to 1%  $\text{O}_2$ .

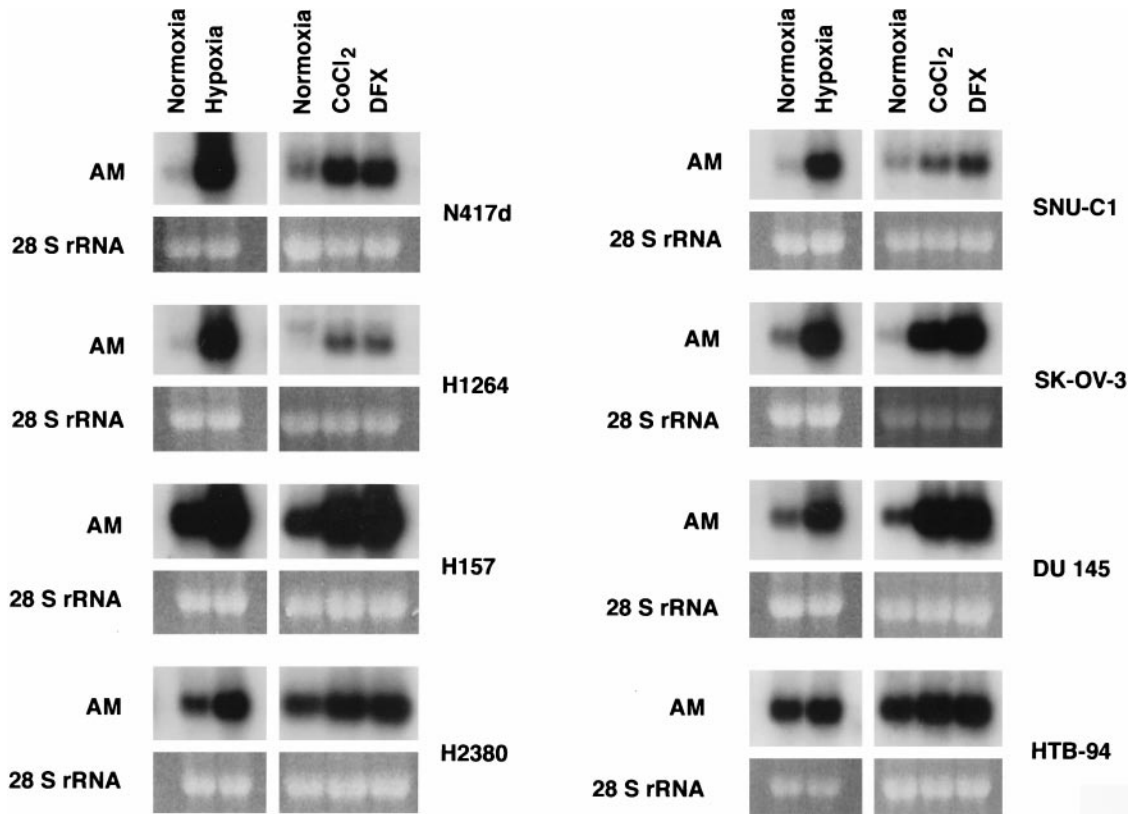

**Fig. 1.** Up-Regulation of AM mRNA in Several Human Tumor Cell Lines under Hypoxic Treatments

Northern blot analysis for AM of cells exposed either to hypoxia mimetics (100  $\mu$ M CoCl<sub>2</sub>, 260  $\mu$ M DFX) for 6 h, or to a hypoxic atmosphere (1% O<sub>2</sub>, 5% CO<sub>2</sub>, 94% N<sub>2</sub>) for 12 h, as compared with untreated cells. Cell lines shown here were selected from a total of 17 cell lines tested and also chosen as representatives of the main human tumor types: carcinomas of the lung (N417d, H1264, H157), breast (H2380), colon (SNUC-1), ovary (K-OV-3), prostate (DU 145), or chondrosarcoma (HTB-94). Fifteen micrograms of total RNA were loaded per lane, and ethidium bromide staining of 28 S rRNA was used to check for equal loading and RNA integrity.

Of the three treatments, exposure to 1% O<sub>2</sub> is the one that shows a steeper induction of AM mRNA over time, and also more dramatic increases between the basal and the maximum induction are observed (>25-fold increase between maximum induction and baseline levels).

We have also performed a parallel analysis for HIF-1 $\alpha$  mRNA in MCF7 cells throughout the hypoxic studies. HIF-1 $\alpha$  transcript levels remained constant or showed a slight decline over time in the CoCl<sub>2</sub> and 1% O<sub>2</sub> time course studies (Fig. 2, A and C). This observation is in accordance with other reports indicating that HIF-1 $\alpha$  is mainly regulated not at the transcriptional level but by protein stabilization in hypoxia, whereas the protein is rapidly degraded by the ubiquitin-proteasome pathway during normoxic conditions (19, 25).

#### Under Hypoxic Conditions, AM Is Also Induced at the Protein Level

To address whether the induction of AM mRNA was accompanied by an increase in the production of AM

protein, the presence and cellular localization of AM and HIF-1 $\alpha$  in tumor cell lines at normoxic or hypoxic conditions were studied using double immunofluorescence followed by confocal microscopy. A typical image is shown in Fig. 3, in which prostate carcinoma DU 145 cells are immunostained for both AM (*green* fluorescence) and HIF-1 $\alpha$  (*red* fluorescence). At normoxic conditions (Fig. 3, A and B), both AM and HIF-1 $\alpha$  are moderately expressed in the cytoplasm and nucleus of the cells. After 12 h exposure to 260  $\mu$ M DFX, the cells showed a marked increase of AM staining in the cytoplasm and nucleus (Fig. 3C); in agreement with our previous results (26) HIF-1 $\alpha$  immunoreactivity is primarily elevated in the nucleus of the cells (Fig. 3D). Similar patterns of staining were obtained with H157, MCF7, and SNUC-1 cell lines (data not shown).

Since we and other investigators have reported a rapid secretion of the bioactive processed AM peptide by human tumor cells and endothelial cells (13, 27), we also examined the presence of AM in the conditioned medium of MCF7 under hypoxic conditions. As is shown in Fig. 4, a significant increase in immunoreactive AM (IR-AM) was observed for MCF7 cells treated

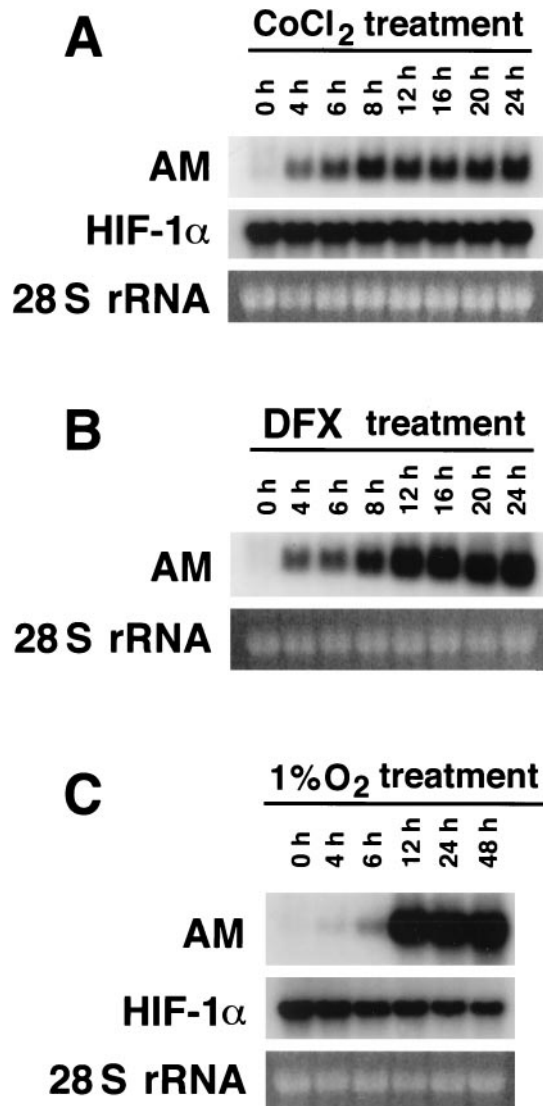

**Fig. 2.** Time Course Analysis of AM Expression

Northern blot analysis of MCF7 cells cultured under 100  $\mu\text{M}$   $\text{CoCl}_2$  (A), 260  $\mu\text{M}$  DFX (B), or 1%  $\text{O}_2$  (C) for the indicated times. Fifteen micrograms of total RNA were loaded per lane and hybridized subsequently with human AM and human HIF-1 $\alpha$  cDNA probes. Equal loading was monitored by ethidium bromide staining of 28 S rRNA for each blot.

with 1%  $\text{O}_2$  at various times as compared with the cells maintained in normoxic conditions. Increasing values of accumulated IR-AM in the conditioned media of this cell line were also observed for the  $\text{CoCl}_2$  or DFX treatments (data not shown).

#### The Hypoxic Induction of AM mRNA Is Dependent on HIF-1

To determine whether the hypoxic up-regulation of AM mRNA was driven by HIF-1, we used cell lines derived from HIF-1 $\alpha$  or HIF-1 $\beta$  knockout mice to evaluate AM induction capabilities as compared with those of their

wild-type counterparts under hypoxic treatments. Figure 5A illustrates an experiment designed to compare AM mRNA levels in these cell lines when subjected to 6 h treatment of  $\text{CoCl}_2$  or DFX. It is shown that HIF-1 $\alpha$  null (-/-) mouse fibroblast cells failed to induce AM mRNA expression in these conditions, while the wild-type HIF-1 $\alpha$  (+/+) fibroblasts showed an inducible response. Similarly, normal HIF-1 $\beta$  (+/+) mouse embryonic stem (ES) cells demonstrated an inducible response, whereas HIF-1 $\beta$  null (-/-) ES cells showed a 32% and a 60% reduced induction when compared with the wild-type control, depending on the test reagent examined.

In addition, when HIF-1 $\alpha$  +/+ and HIF-1 $\alpha$  -/- cell lines were exposed to a hypoxia (1%  $\text{O}_2$ ) time course study (Fig. 5B), the hypoxic induction of AM mRNA was not detectable on the cells with the null mutation, although it was present in the wild-type cells. We also analyzed the levels of HIF-1 $\alpha$  message expression in this experiment. Note that HIF-1 $\alpha$  mRNA remained constant through the hypoxia treatment; however, HIF-1 $\alpha$  transcripts in HIF-1 $\alpha$  -/- cells present a higher molecular size than in the corresponding wild-type cells, since the null mutation was obtained by replacement of the helix-loop-helix domain of HIF-1 $\alpha$  with a neomycin resistance cassette (28).

Furthermore, artificial manipulation of HIF-1 activity with appropriate biochemical reagents was also used to elucidate the role of this transcription factor in AM message regulation under hypoxia. In this sense, the nitric oxide donor sodium nitroprusside (SNP) as well as genistein (a tyrosine kinase inhibitor), are known to inhibit HIF-1 activity by blocking the synthesis of HIF-1 subunits and/or interfering with HIF-1 DNA binding activity in hypoxia (29, 30). MCF7 cells were cultured for 12 h in normoxic or hypoxic conditions, with or without the appropriate biochemical reagents, and AM mRNA expression was analyzed comparing the treated vs. the nontreated cells (control). As is shown in Fig. 6, addition of 100  $\mu\text{M}$  SNP completely inhibited the induced expression of AM mRNA after 12 h of hypoxia (1%  $\text{O}_2$ ) treatment, while genistein at 100  $\mu\text{M}$  was a less potent suppressor of the AM mRNA induction mediated by low oxygen tension. Thus, the inhibited activity of HIF-1 with SNP and genistein is correlated with a suppressive effect on the AM mRNA hypoxic induction. Conversely, it has been reported that the CO scavenger hemoglobin (Hb) enhances HIF-1 activity by increasing HIF-1 DNA binding (31). Treatment of MCF7 cells with 50  $\mu\text{M}$  Hb was shown to further increase AM mRNA expression under hypoxic conditions by approximately 1.7-fold (Fig. 6).

#### Stabilization of AM Transcripts under Hypoxia

Hypoxia-induced up-regulation of gene expression can be mediated both by *de novo* synthesis of mRNA and by stabilization of the normally labile mRNAs under hypoxic conditions. To test whether the latter possibility was involved in the induced response of AM to



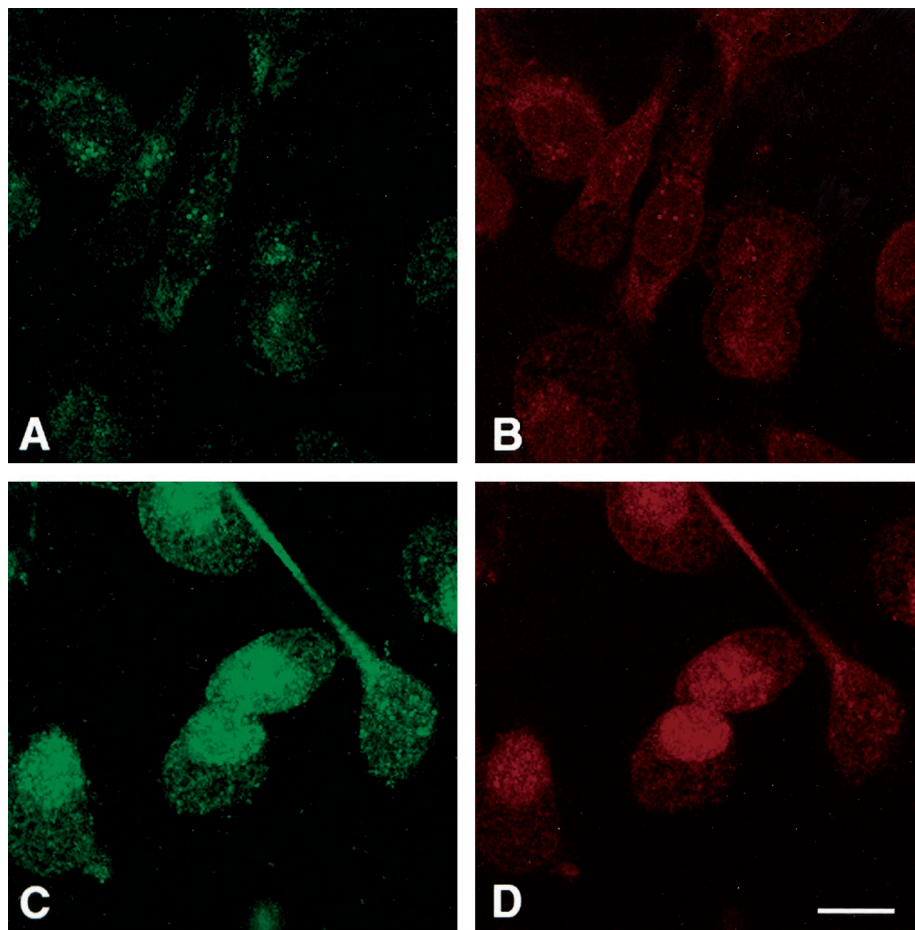

**Fig. 3.** Double Immunostaining for AM and HIF-1 $\alpha$  on DU 145 Cells Analyzed by Confocal Microscopy

Cells were grown on glass slides, left under normoxic conditions (A and B), or treated with 260  $\mu$ M DFX for 12 h (C and D), and then immunostained for AM and HIF-1 $\alpha$ . Equal microscope settings and exposures were maintained on images from normoxic/DFX-treated cells, to compare expression under both conditions. Both AM (A and C) and HIF-1 $\alpha$  (B and D) become markedly overexpressed after 12 h of DFX treatment. Bar = 5  $\mu$ m.

hypoxia, we examined the half-life of AM transcripts under normoxic and hypoxic conditions in the presence of actinomycin D, a compound known to inhibit RNA synthesis. MCF7 cells were maintained under hypoxic (1% O<sub>2</sub>) conditions for 12 h to sufficiently induce the expression of AM transcripts, and AM mRNA level at this point was considered the standard to which the rest of the samples were compared. After the initial hypoxic induction, actinomycin D was added at 4  $\mu$ g/ml, and the cells were further maintained at normoxic or hypoxic (1%O<sub>2</sub>) conditions from 1 to 4 h. As shown in Fig. 7, AM mRNA clearly decayed more rapidly under normoxic than under hypoxic conditions, thus indicating a stabilization process in hypoxia.

Densitometry analysis of the degradation of AM mRNA under normoxia and hypoxia in this experiment was performed, and the pooled data resulted in a calculated half-life of the AM mRNA of 1.7 h under normoxia and of 2.5 h under hypoxia. Our data thus indicate that the hypoxia-induced expression of AM

transcripts is at least partially dependent upon stabilization of AM mRNA.

#### Identification of Putative Hypoxia-Response Element (HRE) Sites in the Human AM Gene

Since it is known that HIF-1 mediated gene transactivation involves its binding to distinct nucleic acid motifs, namely HREs, we used GCG computer software from Genetics Computer Group (Madison, WI) to analyze the human and mouse AM genes (GenBank accession nos. D43639 and D78349, respectively) for appropriate HRE sequences. In this analysis we followed the HRE consensus motif proposed by Wenger and Gassmann (18, 32): (T,G,C) (A,G) CGTG (C,G,A) (G,T,C) (G,T,C) (C,T,G), which has been constructed from the nucleotide sequence of HIF-1 binding sites of 13 oxygen-dependent genes, and allowed for no more than a single base mismatch outside the CGTG core sequence. We have analyzed not only the 5'-promoter region but also the 3'-flanking region, introns/exons,

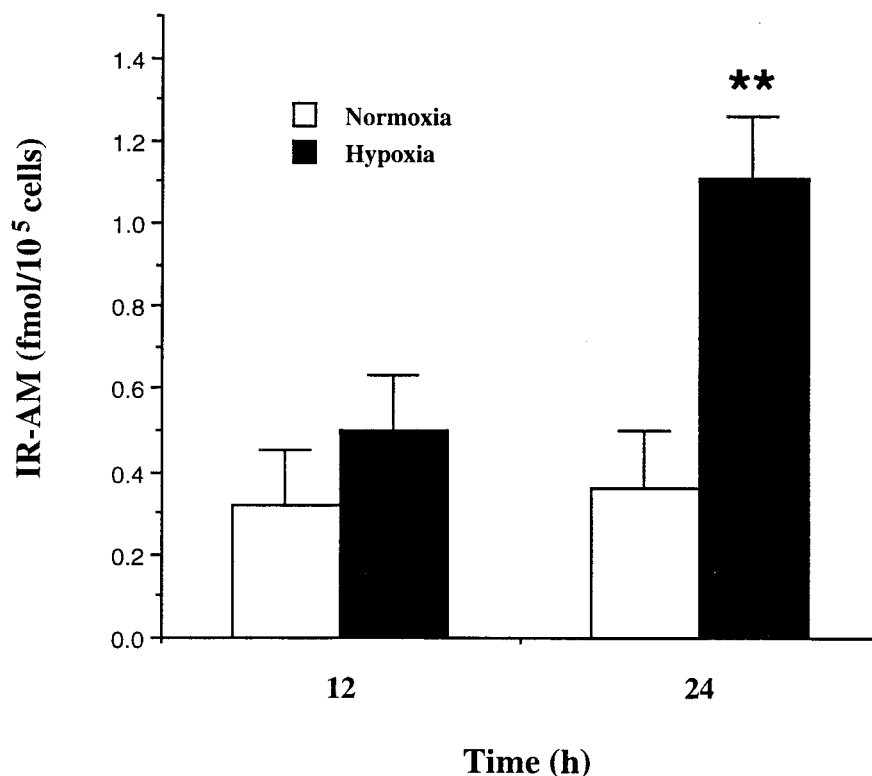

**Fig. 4.** RIA of IR-AM in the Conditioned Media of MCF7 Cells Cultured under Normoxia or 1% O<sub>2</sub> Atmosphere

After 12 h treatment, levels of AM detected in the conditioned medium of cells in both conditions are similar; however, at 24 h, values of accumulated IR-AM in cultured media of 1% O<sub>2</sub> treated cells were significantly higher than those from normoxic cells (\*\*,  $P = 0.004$ ). Values are the mean  $\pm$  SEM.

and looked for consensus motifs in both sense and antisense strands, since these genomic areas have been previously shown to have functional HRE sites in other HIF-1-inducible genes (18, 20, 33). With these premises, eight putative HRE sites at the 5'- and six sites at the 3'-untranslated flanking sequences of the human AM gene were found, together with putative HRE sequences in the first intron and in exon 3 and exon 4 (see Fig. 8). Similar analysis of the mouse AM gene identified three putative HRE sites in the antisense strand of the 5'-promoter region (positions: -1143, [AACTCACGgA]; -98, [CAAGCACGcT]; and -62, [tGACCACGCC]), and another three on the sense orientation: one in intron 1 (position 533, [CGCGTGCTGa]), one in intron 2 (position 727, [GcCGTGCTTT]), and finally one at exon 4 (position: 1960, [GACGTGAaTG]).

#### Luciferase Reporter Assays for the Human AM Promoter Region under Hypoxia

To determine whether these HRE sites were actually involved in the regulation of AM mRNA expression, luciferase reporter studies were performed for different regions of the 5'-flanking region of the human AM gene. MCF7 cells were transiently transfected with the empty parental plasmid (pGL2basic) or with con-

structs comprising one, two, four, or eight putative HREs of the AM promoter (see Fig. 9A). A cotransfected  $\beta$ -galactosidase expression vector served as internal control for transfection efficiency and extract preparation. After the transfection, cells were left under normoxic conditions or exposed to 260  $\mu$ M DFX for 24 h, and luciferase activity was determined. No significant increase for the luciferase activity in the DFX-treated cells/normoxic cells was obtained when transfections were performed with constructs containing the one or two putative HREs closest to the TATA box (Fig. 9A). However, when cells were transfected with constructs containing four or eight putative HREs sites at the 5'-end of the TATA box, a significant ( $P < 0.01$ ) 1.5- and 1.7-fold increase in luciferase activity was observed when comparing DFX-treated vs. normoxic cells.

To test whether we could potentiate the increase in luciferase activity for the DFX treated/normoxic cells, we performed transient expression experiments using the HIF-1 $\alpha$  expression vector pCMV $\beta$ -HA-HIF-1 $\alpha$  (34). This expression vector was cotransfected into MCF7 cells together with the empty parental vector or plasmid constructs containing four or eight HREs from the AM promoter (pGL2basic, pGL2b-4, or pGL2b-8), and the normalization  $\beta$ -galactosidase plasmid. A repre-

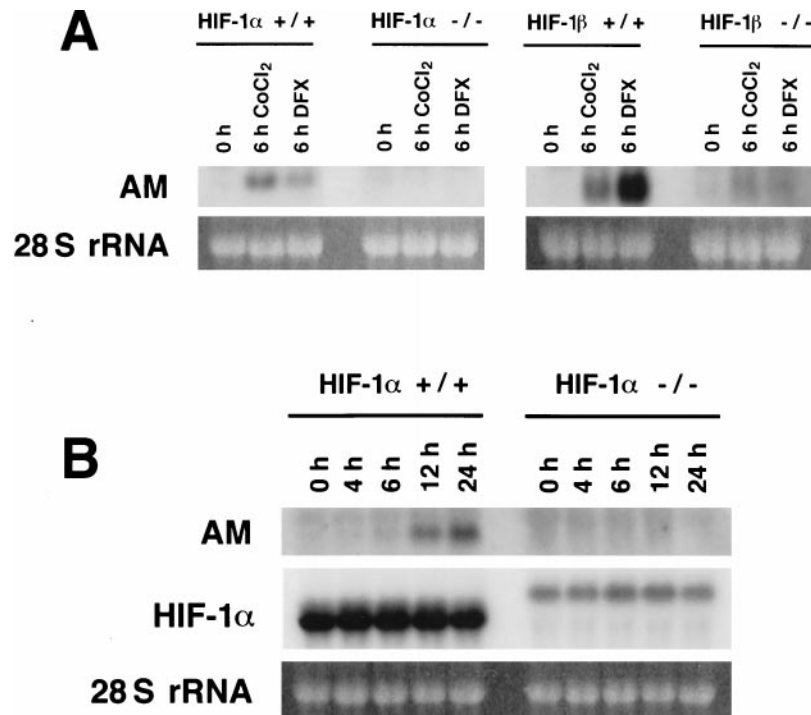

**Fig. 5.** Northern Blot Analysis on HIF-1 $\alpha$  and HIF-1 $\beta$  Knockout Mouse Cell Lines  
Fifteen micrograms of total RNA were loaded per lane, and equal loading and integrity of RNA were monitored by ethidium bromide staining of 28 S rRNA. A, AM mRNA induction is suppressed in fibroblast HIF-1 $\alpha$   $-/-$  cells or reduced in ES HIF-1 $\beta$   $-/-$  cells treated with CoCl<sub>2</sub> or DFX for 6 h as compared with their wild-type counterparts. B, Hypoxia (1% O<sub>2</sub>) time course study on HIF-1 $\alpha$  wild-type (+/+) and HIF-1 $\alpha$  null cells (-/-) probed for mouse AM and HIF-1 $\alpha$ . Note that HIF-1 $\alpha$  null cells fail to induce AM mRNA expression.

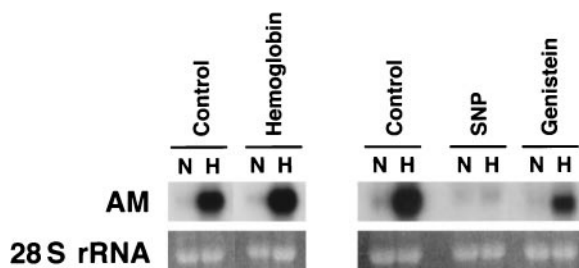

**Fig. 6.** Expression of AM mRNA in MCF7 Cells Treated with Reagents That Modulate HIF-1 Activity

Northern blot analysis was performed on MCF7 cells cultured for 12 h in a normoxic or hypoxic (1% O<sub>2</sub>) fashion with or without 50  $\mu$ M Hb, 100  $\mu$ M SNP, or 100  $\mu$ M genistein. The hypoxic induction of AM transcripts in hypoxia was further augmented with Hb (a reagent that enhances HIF-1 activity), whereas SNP and genistein (known to inhibit HIF-1 activity) had a suppressive effect on that induction.

sentative experiment is shown in Fig. 9B, in which the transient overexpression of HIF-1 $\alpha$  augmented the luciferase reporter activity after DFX treatment up to 2.9-fold when four HREs were present, and up to 4.8-fold with eight HREs as compared with the values of transfected cells in normoxic conditions; no significant increase was observed when the HIF-1 $\alpha$  expression vector was cotransfected with the pGL2basic empty vector.

## DISCUSSION

Oxygen availability is known to play a key role in the growth-regulatory process underlying carcinogenesis (15). Seminal work by Semenza and collaborators (35, 36) demonstrated the general involvement of HIF-1 in the transcriptional response to hypoxia. Since then, several established growth modulation factors, including Epo, VEGF, Tf, ET-1, and insulin-like growth factor binding protein 1 (IGFBP-1), have been shown to be under HIF-1 transcriptional control (18, 20, 33). Based on previous reports showing that AM functions as an autocrine growth factor for certain human tumor cell lines (13), we began a comprehensive study to determine whether hypoxia could influence the expression of AM via HIF-1 in human tumor cell lines as an *in vitro* approach for similar conditions occurring in solid human cancers.

Our initial analysis by Northern blot in a variety of human tumor cell lines clearly demonstrates that hypoxia increases mRNA levels in these cells as compared with the untreated controls. Interestingly, there is a considerable variation in the basal levels of AM mRNA observed in normoxic conditions. High levels of basal AM mRNA may arise from the constitutive expression of HIF-1 $\alpha$  protein in certain cells, a condition that has been previously reported for primary cultures of human pulmonary arterial smooth muscle cells (37).

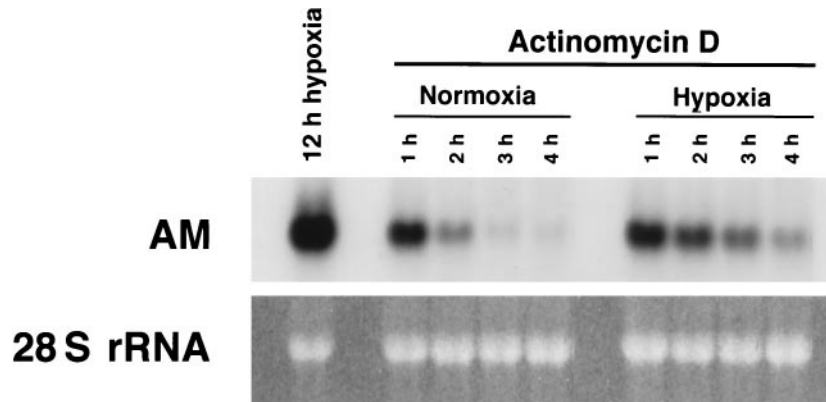

**Fig. 7.** Stabilization of AM Transcripts under Hypoxia

MCF7 cells were treated with 1% O<sub>2</sub> for 12 h to induce the expression of AM mRNA. After addition of actinomycin D at 4 μg/ml, cells were further maintained in normoxic or hypoxic conditions for the indicated times. Fifteen micrograms of total RNA were then loaded in each lane for Northern blot analysis of AM transcripts. AM mRNA levels at each point were compared with levels observed at 12 h hypoxia (previous to the addition of actinomycin D), and the half-life for AM transcripts under normoxic and hypoxic conditions was estimated.

In the time course experiments using MCF7 cells subjected to an hypoxic environment, we also demonstrate that the AM mRNA induction is paralleled by a somewhat delayed increased secretion of AM peptide from the cells to the conditioned media. Given our prior finding that endogenous AM functions as an autocrine growth factor for MCF7 (13), the demonstration that hypoxia augments bioactive AM production and secretion in these cells suggests that a similar scenario may take place in tissue neoplasms. The production and secretion of AM at the hypoxic areas present in tumors (15) could establish an autocrine/paracrine-mediated proliferation event leading to tumor growth. In addition, since AM has angiogenic and vasodilator capabilities (1, 6), the secreted AM could induce neovascularization and facilitate nutritional supplementation to the tumor cells. Finally, AM also has been shown to protect cells from apoptosis (5), and this feature could selectively rescue tumor cells from programmed cell death and might even predispose tumors to a more malignant phenotype (15).

The data obtained with the HIF-1α and HIF-1β knockout mouse cell lines, together with those from the HIF-1 biochemical modulation studies performed on MCF7 cells, provide consistent evidence supporting the major involvement of HIF-1 in the transcriptional activation of AM by hypoxia and suggest that AM could be considered a new member of the growing family of HIF-1-targeted genes. The absence of inducible AM mRNA expression in HIF-1α null mouse fibroblast cell line under hypoxia seems to highlight the critical importance of the HIF-1α subunit in the transactivation of AM mRNA. Recent studies with HIF-1α knockout mice have shown this genetic deletion to be an embryonic lethal event in the later stages of fetal development (28, 38). In addition, tumors derived from mouse ES cells with HIF-1α null genotype have retarded growth, reduced VEGF expression, and less angiogenesis than their wild-type counterparts (28).

Given that AM is also highly expressed during embryogenesis (8), it would be interesting to evaluate whether there are modifications in the AM distribution patterns in early HIF-1α null embryos. HIF-2α, a hypoxia-inducible transcription factor sharing homology with HIF-1α, has recently been shown to be essential in embryonic vascularization and catecholamine production (39); we cannot exclude a possible role of HIF-2α in AM transactivation in endothelial and catecholamines-producing cells of embryos as well as catecholamines-producing tumors. In contrast to HIF-1α knockout cell lines, ES HIF-1β null cells under hypoxia showed a diminished AM mRNA induction as compared with their wild-type counterparts, which may reflect the ability of other basic helix-loop-helix family members (e.g. ARNT 2 and ARNT 3) to compensate for the loss of HIF-1β in the formation of a functional heterodimer with HIF-1α, albeit at lower efficiency (40, 41).

Prior studies have demonstrated the ability of reduced oxygen tension to mediate elevations in AM message/protein expression in several animal and cell systems. In this sense, hypoxia was shown to induce AM gene expression and secretion in cultured human umbilical vein endothelial cells (42); focal ischemic regions of the rat brain show high AM mRNA expression (43), and patients with chronic obstructive pulmonary disease involving tissue hypoxia have elevated AM plasma levels (44). Nakayama and colleagues (14) have demonstrated that hypoxia can elevate AM mRNA and protein expression in a single human colorectal carcinoma cell line, DLD-1; however, these investigators did not identify any HRE motifs in the 5'-upstream flanking region of the human AM gene and suggested the possible involvement of AP-1 in the hypoxia elevation they observed. Given that the AM promoter has several AP-1 binding motifs and that hypoxia can elevate *c-fos*, which in turn can activate AP-1 expression (45, 46), their supposition had a log-



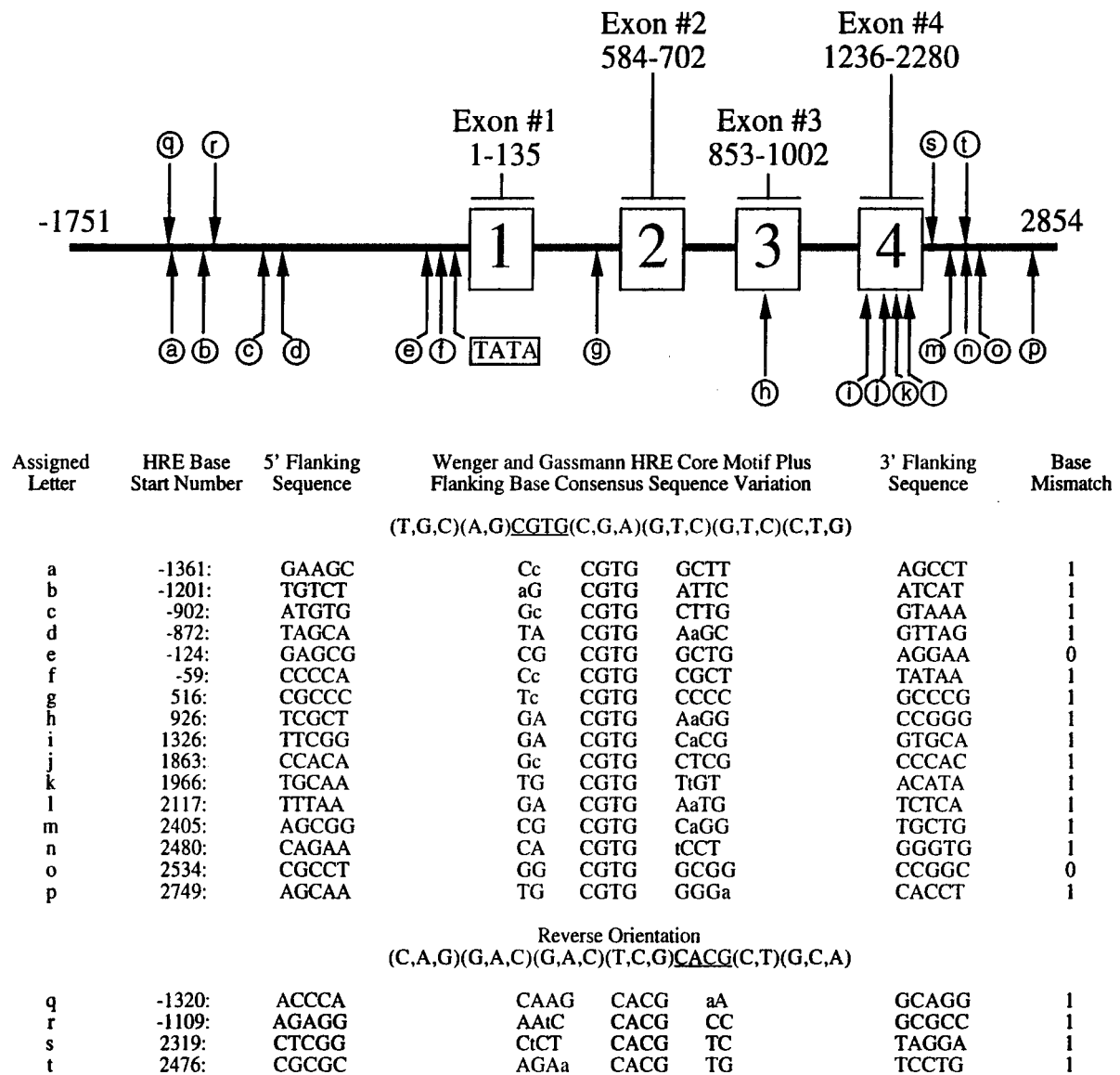

**Fig. 8.** Schematic Drawing of Potential HRE Motifs in the Human AM Gene

Genomic structure was taken from GenBank accession no. D43639. Identification of putative HIF-1 binding sites is derived from the HRE consensus sequence model of Wenger and Gassmann (18, 32), which represents the deca base region (T,G,C)(A,G)CGTG(C,G,A)(G,T,C)(G,T,C)(C,T,G), and allowing for only one base mismatch outside the CGTG core structure. HRE sites in the schematic drawing are indicated by lowercase letters within circles. GCG analysis was performed in both sense and antisense orientation, and nucleotide positioning of HRE sites was based on the AM transcriptional start site as +1. Accompanying chart identifies numerical positioning of HRE, single mismatched base, and 5'- and 3'-flanking sequences.

ical basis and may in fact work in concert with our observed HIF-1-driven AM expression. Recently, it was also reported that the hypoxic expression of AM in rodent cardiomyocytes is under HIF-1 control (47); although Cormier-Regard and colleagues clearly demonstrate the induction of AM mRNA under hypoxia, no experimental data confirming a similar relationship for AM peptide were shown.

In our luciferase reporter studies, MCF7 cells were transfected with reporter plasmid constructs containing one, two, four, or eight of the putative HRE con-

sensus sequences that we identified in the human AM promoter. Only when four or eight potential HREs were present, a statistically significant fold increase in luciferase expression was observed on exposure to DFX over that of untreated controls. Although the luciferase induction observed in our test conditions is modest, it is within the range observed for the mouse AM gene (47) and human Tf (48). For the human VEGF gene, it has been reported that the increase in transcription rate cannot account for all the observed increase in the steady-state VEGF mRNA levels induced by hypoxia

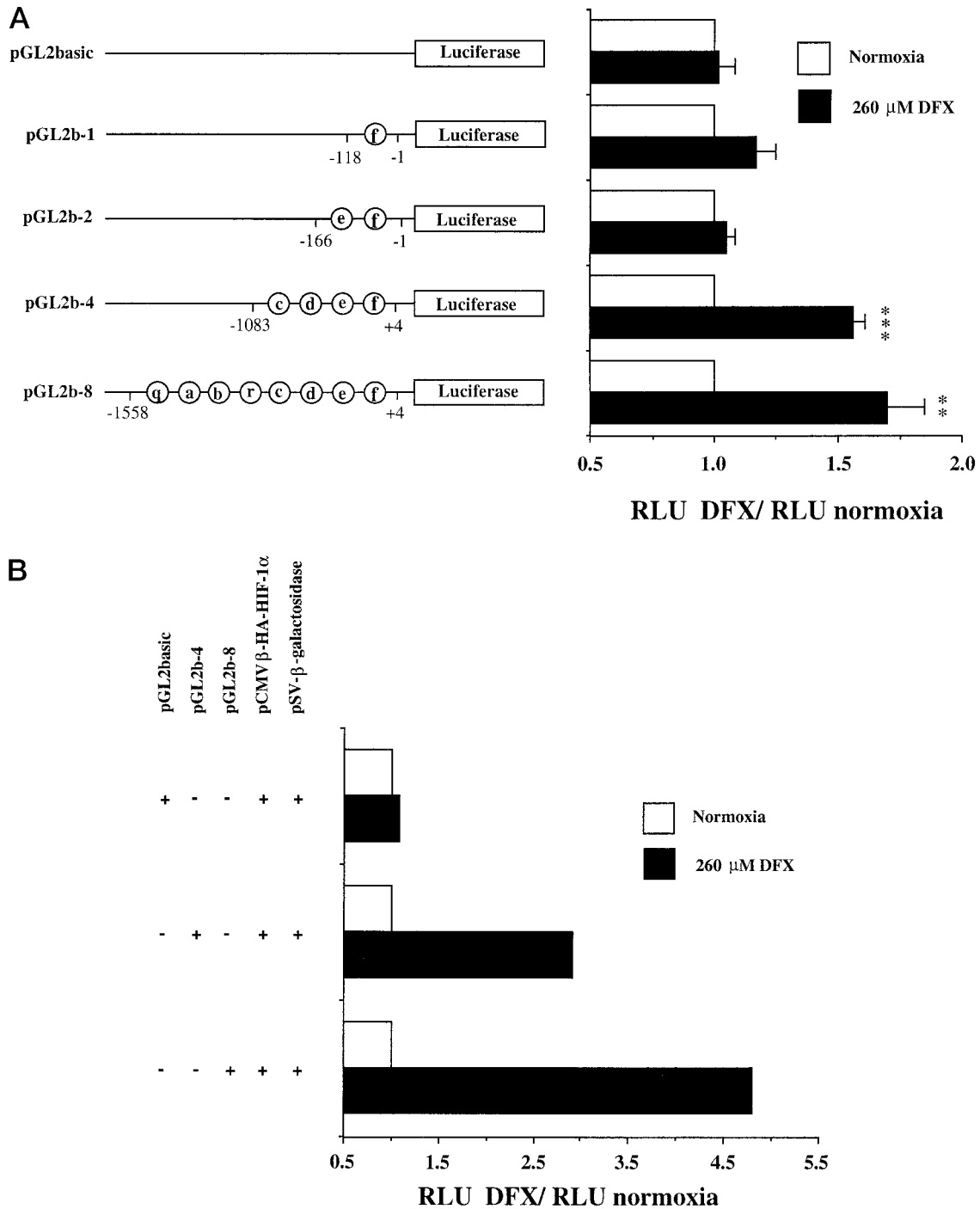

**Fig. 9.** Evaluation of HRE Activity by Luciferase Reporter Assay

A, Hypoxia responsiveness of the human AM 5'-flanking region. Schematic diagrams of the luciferase plasmids used in this study, containing one, two, four, or eight putative HREs are shown on the left. The HRE sites are named in the same way as in Fig. 8, and numbering refers to the region of the AM promoter inserted into the parental pGL2basic vector relative to the AM transcription start site as +1. MCF7 cells were transiently transfected with one of the mentioned luciferase plasmids and a pSV-β-galactosidase control vector. After normoxic or 260 μM DFX exposure for 24 h, luciferase activity was determined by normalization to the corresponding β-galactosidase values. For each construct tested, fold increase of luciferase activities with 260 μM DFX vs. luciferase values in normoxia (arbitrarily defined as 1) are represented. Means ± SEM of three to five independent experiments are shown; \*\*, P < 0.01, \*\*\*, P < 0.001. B, Transient expression of HIF-1α potentiates the enhanced luciferase activity after exposure to DFX. MCF7 cells were transiently cotransfected with the HIF-1α expression vector (pCMVβ-HA-HIF-1α) and the plasmid constructs shown at the left of the figure. After normoxic or 24 h DFX (260 μM) treatment, the luciferase activity was determined, corrected for transfection efficiency according to the β-galactosidase activity, and in each case normalized to the luciferase value in normoxic conditions arbitrarily defined as 1.

(49), and important posttranscriptional regulation events mediated by mRNA stabilization do, in fact, take place (50). A similar situation could also be depicted for the human AM gene, since not only transcriptional activation but also, as we have shown, RNA stabilization events contribute to the AM mRNA up-regulation under hypoxic conditions. We cannot exclude, however, the possibility of major functional HRE sites at the 3'-flanking region of the human AM gene, a location that has been shown for HREs in the human and mouse Epo gene (51, 52). Furthermore, when MCF7 cells were cotransfected with a HIF-1 $\alpha$  expression vector and plasmid constructs containing four or eight HREs of the 5'-flanking region of the human AM gene, the increase in luciferase activity was remarkably potentiated as compared with the increase obtained with the pGL2-4 or pGL2-8 plasmids alone. This stimulated luciferase reporter activity with the transient overexpression of HIF-1 $\alpha$  has also been reported for the human Tf, VEGF, and Epo genes (48, 53). These data further support that the transcriptional activation of AM in hypoxic conditions is driven by HIF-1 and not through other transcriptional factors activated by hypoxia; additionally, they give stronger evidence that at least some of the selected potential HRE sites in the 5'-flanking region of the human AM gene are functional in the up-regulation of AM transcription under hypoxia.

Based on our actinomycin D studies, we clearly demonstrate AM mRNA stabilization mediated by hypoxic conditions. Recent studies on RNA degradation mechanisms have identified hypoxia-inducible proteins that bind to adenylate-uridylylate (AU)-rich elements of the 3'-untranslated region (3'-UTR) of short half-life RNA (*i.e.* VEGF, c-Myc, c-fos) and suppress ribonuclease degradation (54, 55). One such stabilizing RNA-binding protein, HuR, has been shown to interact with AUUUA or AUUUUA base sequences in the 3'-UTR of the VEGF mRNA and to extend its half-life under hypoxic conditions (55). Interestingly, the 3'-UTR of both human and mouse AM mRNA have AUUUA and AUUUUA sequences that could possibly augment message survival during reduced oxygen tension through a similar HuR or HuR-like interaction. In addition, tumor cell lines that have a mutated von Hippel-Lindau (VHL) tumor suppressor gene contain constitutively stabilized VEGF mRNA and also have constitutively expressed stabilizing RNA-binding proteins (54). Considering these reports and the recent discovery by Ratcliffe and co-workers that the VHL gene product controls the degradation of HIF-1 $\alpha$  protein (25), it will be interesting to determine the status of the VHL suppressor gene in those human tumor cell lines that have an elevated basal expression of AM message under normoxic conditions (*i.e.* H157), to determine whether this feature relates to an increased half-life of AM mRNA mediated by constitutive expression of stabilizing RNA-binding proteins.

In conclusion, we have shown evidence in favor of hypoxia as an inducer of AM mRNA and protein ex-

pression in human tumor cell lines. The data obtained from HIF-1 knockout mouse cell lines, biochemical modulation of HIF-1 activity, and transfection experiments give solid proof for the involvement of HIF-1 in the up-regulation of AM mRNA under hypoxic conditions. In addition to HIF-1 transcriptional activation, increased hypoxic mRNA stability also accounts for AM induction based on our actinomycin D assays. Our collective data, taken together with previous reports that most solid human tumors have common hypoxic regions (15) and that AM can function as a mitogen/angiogenic factor/apoptotic survival factor (5, 6, 13), implicate HIF-1/AM as members of a potential promotion mechanism of carcinogenesis and identify a possible biological target for intervention strategies against malignant disease.

## MATERIALS AND METHODS

### Cell Lines, Hypoxia Treatments, and Reagents

Cell lines used in this study were selected to represent an array of the most widely distributed human cancer types. In particular, we used representatives of carcinomas (CA) or carcinoids of the lung [N417d (small cell CA), H1264 (adenocarcinoma), H157 (squamous cell CA), H720 (carcinoid)], breast (H2380, MCF7, SK-BR-3, ZR-75), colon (H630, H716, SNUC-1), ovary (OVCAR-3, SK-OV-3), prostate (DU 145, PC-3-M), chondrosarcoma (HTB-94) or promyelocytic leukemia (HL-60). All cell lines were obtained from the National Cancer Institute-Navy Medical Oncology Branch or purchased through the American Type Culture Collection (ATCC, Manassas, VA). All tumor cell lines were cultured in RPMI 1640 or DMEM media supplemented with 10% heat inactivated FBS, 2 mM L-glutamine, 10 mM HEPES buffer, 100 U/ml penicillin, and 100  $\mu$ g/ml streptomycin (all tissue culture reagents purchased from Life Technologies, Inc., Gaithersburg, MD). The development, characterization, and maintenance of embryonic stem cell lines from HIF-1 $\beta$  knockout mice have been previously described (56). The HIF-1 $\alpha$  (-/-) fibroblast cell line was generated from HIF-1 $\alpha$  null mice (28) via SV-40 transformation of embryonic fibroblast cells; HIF-1 $\alpha$  (-/-), and (+/+) fibroblast cell lines were maintained with the same media as specified for the human tumor cell lines.

Cells were cultured at 37 C in 20% O<sub>2</sub>, 5% CO<sub>2</sub>, 75% N<sub>2</sub> for normoxic conditions, and new media were added 12 h before the beginning of each hypoxia experiment. The hypoxia induction was achieved either by hypoxia mimetics: 100  $\mu$ M CoCl<sub>2</sub>, 260  $\mu$ M DFX mesylate (both from Sigma, St. Louis, MO), or by culturing cells in a hypoxia chamber at 37 C with 1% O<sub>2</sub>, 5% CO<sub>2</sub>, 94% N<sub>2</sub> atmosphere. The hypoxia chamber was fabricated from a Labconco seamless fiberglass vacuum desiccator (Fisher Scientific, Pittsburgh, PA) fitted with two stainless steel angle ball valves having serrated hose connectors (Washington Valve & Fitting Co., Frederick, MD), which allowed for chamber equilibration to hypoxic environment via venting with gas mixture (Roberts Oxygen Co., Gaithersburg, MD). The chamber was tested for leaks under positive pressure using a bubble-forming agent (SNOOP, Nupro Co., Willoughby, OH) and was shown to hold a 3 psi charge for 48 h.

In the HIF-1 modulating studies, different agents were added to the culture media, and then the cells were incubated under normoxic conditions or in the hypoxia chamber for 12 h at 37 C. SNP (a NO donor), and genistein (a tyrosine kinase inhibitor), were used at 100  $\mu$ M to inhibit HIF-1 activity (29, 30). Hemoglobin (Hb), which acts as a CO scavenger, was

used at a final concentration of 50  $\mu\text{M}$  to up-regulate HIF-1 activity (31); Hb was prepared by treatment with excess reducing agent sodium dithionite (57). All reagents were purchased from Sigma.

For the AM mRNA stabilization studies, cells were initially exposed to 12 h hypoxia, after which actinomycin D was added at a final concentration of 4  $\mu\text{g}/\text{ml}$  (Sigma); cells were subsequently maintained from 1 h to 4 h under normoxic or hypoxic conditions.

### Northern Blot Analysis

Immediately after treatment for the indicated times, cells were washed once in PBS, and total RNA was extracted using the guanidine isothiocyanate and cesium chloride method (58). Fifteen micrograms of RNA were loaded per lane, run in 1% agarose gels containing 2.2 M formaldehyde, blotted by capillarity onto nitrocellulose membranes (Schleicher & Schuell, Inc., Keene, NH), and baked for 2 h at 80 C. Equal loading and integrity of RNA were monitored by ethidium bromide staining of the 28 S subunit of rRNA.

The human AM cDNA probe used in this study was generated as an RT-PCR product (831 bp) obtained using oligonucleotide primers: 5'-TACCTGGGTTTCGCTCGCCTTCCTA-3' (sense, bp 184–207) and 5'-CTCCGGGGTCTCAGCATTTCATTT-3' (antisense, bp 991–1014). The human HIF-1 $\alpha$  cDNA probe was also produced by RT-PCR (1308-bp product) using oligonucleotide primers: 5'-CGGCGCGAACGA-CAAGAAAAGAT-3' (sense, bp 43–66) and 5'-TCGTTGGGTGAGGGGAGCATTACA-3' (antisense, bp 1327–1350). Numbering of the nucleotide base positioning was taken from the GenBank profile accession no. D14874 (human AM mRNA) and U22431 (human HIF-1 $\alpha$  mRNA). All RT-PCR products were sequenced to validate base integrity of the probes. The mouse AM cDNA 550-bp probe was a gift from Dr. Sonia Jakowlew (59).

Probes were labeled with [ $\alpha$ -<sup>32</sup>P]dCTP (3000 Ci/mmol; NEN Life Science Products, Boston, MA) by random priming, and unincorporated nucleotides were removed by Probe-Quant G-50 Micro Columns (Amersham Pharmacia Biotech, Piscataway, NJ). Hybridization was carried out overnight at 42 C in a hybridization buffer containing 40% formamide (58). After stringency washes, blots were exposed to XAR film (Eastman Kodak Co., Rochester, NY) at –80 C for varying times. Densitometry of the autoradiograms was performed using a Chemilmager 4000 (Alpha Innotech Corp., San Leandro, CA). The half-life of the endogenous AM mRNA was calculated using Prism 3.0 software.

### Confocal Immunofluorescence for AM and HIF-1 $\alpha$

Cells were grown on glass slides, treated with 260  $\mu\text{M}$  DFX for 12 h, and fixed in Bouin's fluid (Sigma) for 10 min at room temperature. Slides were blocked with normal goat serum (1:30 in PBS) for 30 min and then incubated overnight at 4 C in a mixture of both antibodies: mgc3 antihuman HIF-1 $\alpha$  monoclonal antibody (60) at 1:500 dilution and rabbit antihuman AM 22–52 antibody (13) at 1:1,000 dilution. The second layer consisted on a mixture of Rhodamine-antimouse and Bodipy-antirabbit IgGs (Molecular Probes, Inc., Eugene, OR) at a final concentration of 1:200 each. The cells were observed with a Carl Zeiss Laser Scanning Microscope 510, equipped with four lasers. Images from cells subjected to DFX treatment and normoxic controls were taken with exactly the same microscope settings and exposures, to compare expression of AM and HIF-1 $\alpha$  in both conditions.

### RIA of Immunoreactive AM

Concentrations of AM in culture media of MCF7 cells under hypoxia or mimetics treatment were measured by double

antibody RIA. Samples of culture media (1 ml) were mixed with an equal volume of 0.1% alkali-treated casein in PBS, pH 7.4, and applied to reverse-phase Sep-Pak C-18 cartridges (Waters Corp., Milford, MA). The proteins were eluted with 3 ml of 80% isopropanol containing 0.125 N HCl and lyophilized. Extracts were reconstituted in 0.4 ml of RIA buffer (10 mM phosphate, 50 mM EDTA, 135 mM NaCl, 5 mM NaHCO<sub>3</sub>, 0.05% Triton X-100, 0.1% Tween-20, 0.1% alkali-treated casein, 20 mg/l phenol red, pH 7.4), and spun to remove any solid matter. After a 24-h preincubation of 0.1 ml of sample with 0.1 ml of antihuman AM antibody (Phoenix Pharmaceuticals, Inc., Mountain View, CA) at 4 C, 0.1 ml of <sup>125</sup>I-labeled AM (Phoenix Pharmaceuticals, Inc.) was added (10,000 cpm) and the mixture was incubated at 4 C overnight. Bound tracer was separated by polyethylenglycol-facilitated precipitation with goat antirabbit IgG and normal rabbit serum. After centrifugation, the supernatant was discarded, and the radioactivity in the pellets was determined in a  $\gamma$ -counter. Data were statistically evaluated by a two-tailed Student's *t* test using Prism 3.0 software. Differences were regarded as significant at a value of *P* < 0.05.

### Reporter Plasmid Constructs

A PCR product of 118 bp (–118, –1) containing the putative HRE site closest to the transcription start site in the 5'-flanking region of the AM gene (named HRE f in Fig. 8) was generated using human genomic DNA as template and the following oligonucleotide primers: sense, 5'-GCTGAGGAAA-GAAAGGGAAG-3' and antisense, 5'-TGTCACCAAGAAAC-CACTGA-3'. Similarly, primers: sense, 5'-AGCCCCAAAG-GAAGCAATGC-3' and antisense, 5'-TGTCACCAAGAAACC-ACTGA-3' were used to generate a PCR product of 166 bp (–166, –1) comprising the two potential HREs closest to the transcription start site of the AM promoter (HREs named e and f in Fig. 8). Each of the resulting 118-bp and 166-bp DNA fragments were ligated into the pCR2.1 vector (Invitrogen, Carlsbad, CA) to generate pCR2.1–118 and pCR2.1–166. These plasmids were then digested with *Hind*III and *Xho*I, and the resulting DNA fragments were cloned into the same sites of a promoterless luciferase reporter pGL2basic (Promega Corp., Madison, WI) to generate pGL2b-1 and pGL2b-2, respectively.

The entire 5'-flanking region of the human AM gene was amplified by standard PCR from human genomic DNA using primers: sense, 5'-GAATTCAGGTCCGCTCAGGTGACTCCT-TCC-3' and antisense, 5'-GAGCTCGCTAGCCAGTGTAC-CAAGAAACC-3' (the antisense primer introduced a *Sac*I site [underlined] and an *Nhe*I site [**bolded**]). The resulting 1755 bp (–1751, +4) product was ligated into the pCR2.1 vector to generate pCR2.1–1755. An *Nhe*I/*Nhe*I fragment from pCR2.1–1755 was subcloned into the same site of pGL2basic generating pGL2b-4 (which carries 4 putative HREs from the 5'-end of the AM promoter, namely c, d, e, and f in Fig. 8). In the same way, a *Sac*I/*Sac*I fragment from pCR2.1–1755 was also subcloned into the *Sac*I site of pGL2basic, generating pGL2b-8, which encompasses the 8 putative HREs in the 5'-flanking region of the AM gene (HREs a, b, c, d, e, f, q, and r in Fig. 8). The fidelity of all PCR-derived sequences was verified by sequence analysis. All positions are referred relative to the transcription start site of the AM gene (+1; see Fig. 8).

The HIF-1 $\alpha$  expression vector (pCMV $\beta$ -HA-HIF-1 $\alpha$ ) (34) was generously provided by Dr. D. Livingstone (Dana Farber Cancer Institute).

### Transient Transfections and Luciferase Reporter Assay

Approximately 20 h before transfection 1.5  $\times$  10<sup>5</sup> MCF7 cells were seeded onto 60-mm plates. Each dish was then transfected for 4 h in the presence of lipofectAMINE and Optimum medium I (Life Technologies, Inc.) with 1  $\mu\text{g}$  of pSV- $\beta$ -galac-



tosidase control vector (Promega Corp.) and 3  $\mu\text{g}$  of one of the following plasmids: pGL2basic, pGL2b-1, pGL2b-2, pGL2b-4, or pGL2b-8. For the HIF-1 $\alpha$  transient overexpression assays, 5  $\mu\text{g}$  of the pCMV $\beta$ -HA-HIF-1 $\alpha$  vector were cotransfected with an equal amount of one of the following plasmids: pGL2basic, pGL2b-4, or pGL2b-8, together with 1  $\mu\text{g}$  of pSV- $\beta$ -Galactosidase control vector (quantities referred per dish). All transfections were carried out in duplicate with aliquots of transfection mixture from a single pool. After transfection, cells were incubated in RPMI 1640 medium supplemented with 10% FBS and were either treated with DFX at 260  $\mu\text{M}$  for 24 h or left under normoxic conditions for the same time. Cells were then collected in EBC lysis buffer with protease inhibitors (40 mM Tris, pH 8.0, 120 mM NaCl, 0.5% NP-40, 1 mM AEBSF, 10  $\mu\text{g}/\text{ml}$  aprotinin, 1 mM NaVO<sub>4</sub>, 10  $\mu\text{g}/\text{ml}$  leupeptin), and luciferase and  $\beta$ -galactosidase activities were determined according to the manufacturer's instructions using a TopCount NXT Packard luminometer and a Bio-Rad Laboratories, Inc. 3550 Microplate Reader. Luciferase readings were normalized by the  $\beta$ -galactosidase values to correct for differences in transfection efficiency and extract preparation. For each construct transfectants, data were expressed as fold increase of the luciferase value obtained with the DFX treatment as compared with the luciferase value obtained in normoxic conditions, which was arbitrarily defined as 1. Data were statistically evaluated by a two-tailed one-sample Student's *t* test using Prism 3.0 software. Differences were regarded as significant at a value of  $P < 0.05$ .

### Acknowledgments

We thank Dr. J. A. Calera (Georgetown University Medical Center) for his help in the construction of plasmids as well as for useful comments on the manuscript. We are indebted to Dr. G. Camenish for his gift of mgc3 HIF-1 $\alpha$  antibody, and to Dr. R. H. Wenger for critical reading of the manuscript (Institute of Physiology, University of Zürich-Irchel). We gratefully acknowledge Dr. Y. Ward (Department of Cell and Cancer Biology, National Cancer Institute) for her expertise in confocal microscopy. Authors are also thankful to Drs. E. Maltepe and C. Simon (Howard Hughes Medical Institute, University of Chicago) for the HIF-1 $\beta$  knockout mouse cell line, and to Dr. D. Livingstone (Dana Farber Cancer Institute) for the pCMV $\beta$ -HA-HIF-1 $\alpha$  vector.

Received November 23, 1999. Revision received February 1, 2000. Accepted March 1, 2000.

Address requests for reprints to: Dr. Mercedes Garayoa, Cell and Cancer Biology Department, National Cancer Institute, National Institutes of Health, Building 10/12N226, 9000 Rockville Pike, Bethesda, Maryland 20892-1906. E-mail: garayoam@bprb.nci.nih.gov.

M. Garayoa was supported by a postdoctoral fellowship from the Dirección General de Enseñanza Superior, Ministerio de Educación y Cultura, Spain (PF96 0029138440). R. Pio was recipient of a fellowship from the Instituto de Salud Carlos III, Ministerio de Sanidad y Consumo, Spain (Grant 98/9172). This work was also supported in part by the Swiss National Science Foundation (3100-56743.99).

### REFERENCES

1. Kitamura K, Kangawa K, Kawamoto M, Ichiki Y, Nakamura S, Matsuo H, Eto T 1993 Adrenomedullin: a novel hypotensive peptide isolated from human pheochromocytoma. *Biochem Biophys Res Commun* 192:553-560

2. Barker S, Wood E, Clark AJ, Corder R 1998 Cloning of bovine preproadrenomedullin and inhibition of its basal expression in vascular endothelial cells by staurosporine. *Life Sci* 62:1407-1415
3. Kitamura K, Kangawa K, Matsuo H, Eto T 1998 Structure and function of adrenomedullin and PAMP. In: Martínez A, Cuttitta F (eds) *Adrenomedullin*. IOS Press/Ohmsha Ltd., Amsterdam, Tokyo, pp 27-39
4. Cuttitta F, Miller MJ, Montuenga LM, Garayoa M, Elsasser T, Walsh T, Unsworth E, Martínez A 1998 Adrenomedullin: *terra incognita*. In: Martínez A, Cuttitta F (eds) *Adrenomedullin*. IOS Press/Ohmsha Ltd., Amsterdam, Tokyo, pp 1-26
5. Kato H, Shichiri M, Marumo F, Hirata Y 1997 Adrenomedullin as an autocrine/paracrine apoptosis survival factor for rat endothelial cells. *Endocrinology* 138:2615-2620
6. Zhao Y, Hague S, Manek S, Zhang L, Bicknell R, Rees MC 1998 PCR display identifies tamoxifen induction of the novel angiogenic factor adrenomedullin by a non estrogenic mechanism in the human endometrium. *Oncogene* 16:409-415
7. Martínez A, Cuttitta F, Teitelman G 1998 Expression pattern for adrenomedullin during pancreatic development in the rat reveals a common precursor with other endocrine cell types. *Cell Tissue Res* 293:95-100
8. Montuenga LM, Martínez A, Miller MJ, Unsworth EJ, Cuttitta F 1997 Expression of adrenomedullin and its receptor during embryogenesis suggests autocrine or paracrine modes of action. *Endocrinology* 138:440-451
9. Morrish DW, Linetsky E, Bhardwaj D, Li H, Dakour J, Marsh RG, Paterson MC, Godbout R 1996 Identification by subtractive hybridization of a spectrum of novel and unexpected genes associated with *in vitro* differentiation of human cytotrophoblast cells. *Placenta* 17:431-441
10. Liu J, Kahri AI, Heikkilä P, Voutilainen R 1997 Adrenomedullin gene expression and its different regulation in human adrenocortical and medullary tumors. *J Endocrinol* 155:483-490
11. Satoh F, Takahashi K, Murakami O, Totsune K, Sone M, Ohneda M, Abe K, Miura Y, Hayashi Y, Sasano H, Ouri T 1995 Adrenomedullin in human brain, adrenal glands and tumor tissues of pheochromocytoma, ganglioneuroblastoma and neuroblastoma. *J Clin Endocrinol Metab* 80:1750-1752
12. Ehlenz K, Koch B, Preuss P, Simon B, Koop I, Lang RE 1997 High levels of circulating adrenomedullin in severe illness: correlation with C-reactive protein and evidence against the adrenal medulla as site of origin. *Exp Clin Endocrinol Diabetes* 105:156-162
13. Miller MJ, Martínez A, Unsworth EJ, Thiele CJ, Moody TW, Elsasser T, Cuttitta F 1996 Adrenomedullin expression in human tumor cell lines. Its potential role as an autocrine growth factor. *J Biol Chem* 271:23345-23351
14. Nakayama M, Takahashi K, Murakami O, Shirato K, Shibahara S 1998 Induction of adrenomedullin by hypoxia and cobalt chloride in human colorectal carcinoma cells. *Biochem Biophys Res Commun* 243:514-517
15. Brown JM, Giaccia AJ 1998 The unique physiology of solid tumors: opportunities (and problems) for cancer therapy. *Cancer Res* 58:1408-1416
16. Genbacev O, Zhou Y, Ludlow JW, Fisher SJ 1997 Regulation of human placental development by oxygen tension. *Science* 277:1669-1672
17. LaVan FB, Hunt TK 1990 Oxygen and wound healing. *Clin Plast Surg* 17:463-472
18. Wenger RH, Gassmann M 1997 Oxygen(es) and the hypoxia-inducible factor-1. *Biol Chem* 378:609-616
19. Huang LE, Gu J, Schau M, Bunn HF 1998 Regulation of hypoxia-inducible factor 1 $\alpha$  is mediated by an O<sub>2</sub>-dependent degradation domain via the ubiquitin-proteasome pathway. *Proc Natl Acad Sci USA* 95:7987-7992

20. Hu J, Discher DJ, Bishopric NH, Webster KA 1998 Hypoxia regulates expression of the endothelin-1 gene through a proximal hypoxia-inducible factor-1 binding site on the antisense strand. *Biochem Biophys Res Commun* 245:894–899
21. Dachs GU, Chaplin DJ 1998 Microenvironmental control of gene expression: implications for tumor angiogenesis, progression, and metastasis. *Semin Radiat Oncol* 8:208–216
22. Gassmann M, Fandrey J, Bichet S, Wartenberg M, Marti HH, Bauer C, Wenger RH, Acker H 1996 Oxygen supply and oxygen-dependent gene expression in differentiating embryonic stem cells. *Proc Natl Acad Sci USA* 93:2867–2872
23. Hasan NM, Adams GE, Joiner MC, Marshall JF, Hart IR 1998 Hypoxia facilitates tumour cell detachment by reducing expression of surface adhesion molecules and adhesion to extracellular matrices without loss of cell viability. *Br J Cancer* 77:1799–1805
24. Yuan J, Glazer PM 1998 Mutagenesis induced by the tumor microenvironment. *Mutat Res* 400:439–446
25. Maxwell PH, Wiesener MS, Chang GW, Clifford SC, Vaux EC, Cockman ME, Wykoff CC, Pugh CW, Maher ER, Ratcliffe PJ 1999 The tumour suppressor protein VHL targets hypoxia-inducible factors for oxygen-dependent proteolysis. *Nature* 399:271–275
26. Chilov D, Camenisch G, Kvietikova I, Ziegler U, Gassmann M, Wenger RH 1999 Induction and nuclear translocation of hypoxia-inducible factor-1 (HIF-1): heterodimerization with ARNT is not necessary for nuclear accumulation of HIF-1 $\alpha$ . *J Cell Sci* 112:1203–1212
27. Isumi Y, Shoji H, Sugo S, Tochimoto T, Yoshioka M, Kangawa K, Matsuo H, Minamino N 1998 Regulation of adrenomedullin production in rat endothelial cells. *Endocrinology* 139:838–846
28. Ryan HE, Lo J, Johnson RS 1998 HIF-1 $\alpha$  is required for solid tumor formation and embryonic vascularization. *EMBO J* 17:3005–3015
29. Sogawa K, Numayama-Tsuruta K, Ema M, Abe M, Abe H, Fujii-Kuriyama Y 1998 Inhibition of hypoxia-inducible factor 1 activity by nitric oxide donors in hypoxia. *Proc Natl Acad Sci USA* 95:7368–7373
30. Wang GL, Jiang BH, Semenza GL 1995 Effect of protein kinase and phosphatase inhibitors on expression of hypoxia-inducible factor 1. *Biochem Biophys Res Commun* 216:669–675
31. Liu Y, Christou H, Morita T, Laughner E, Semenza GL, Kourembanas S 1998 Carbon monoxide and nitric oxide suppress the hypoxic induction of vascular endothelial growth factor gene via the 5' enhancer. *J Biol Chem* 273:15257–15262
32. Wenger RH, Gassmann M 1999 HIF-1 and the molecular response to hypoxia in mammals. In: Storey KB (ed) *Environmental Stress and Gene Regulation*. BIOS Scientific Publishers Ltd., Oxford, UK, pp 25–45
33. Tazuke SI, Mazure NM, Sugawara J, Carland G, Faessen GH, Suen LF, Irwin JC, Powell DR, Giaccia AJ, Giudice LC 1998 Hypoxia stimulates insulin-like growth factor binding protein 1 (IGFBP-1) gene expression in HepG2 cells: a possible model for IGFBP-1 expression in fetal hypoxia. *Proc Natl Acad Sci USA* 95:10188–10193
34. Eckner R, Ewen ME, Newsome D, Gerdes M, DeCaprio JA, Lawrence JB, Livingston DM 1994 Molecular cloning and functional analysis of the adenovirus E1A-associated 300-kD protein (p300) reveals a protein with properties of a transcriptional adaptor. *Genes Dev* 8:869–884
35. Semenza GL, Roth PH, Fang HM, Wang GL 1994 Transcriptional regulation of genes encoding glycolytic enzymes by hypoxia-inducible factor 1. *J Biol Chem* 269:23757–23763
36. Wang GL, Semenza GL 1993 Characterization of hypoxia-inducible factor 1 and regulation of DNA binding activity by hypoxia. *J Biol Chem* 268:21513–21518
37. Yu AY, Frid MG, Shimoda LA, Wiener CM, Stenmark K, Semenza GL 1998 Temporal, spatial, and oxygen-regulated expression of hypoxia-inducible factor-1 in the lung. *Am J Physiol* 275:L818–826
38. Iyer NV, Kotch LE, Agani F, Leung SW, Laughner E, Wenger RH, Gassmann M, Gearhart JD, Lawler AM, Yu AY, Semenza GL 1998 Cellular and developmental control of O<sub>2</sub> homeostasis by hypoxia-inducible factor 1 $\alpha$ . *Genes Dev* 12:149–162
39. Tian H, Hammer RE, Matsumoto AM, Russell DW, McKnight SL 1998 The hypoxia-responsive transcription factor EPAS1 is essential for catecholamine homeostasis and protection against heart failure during embryonic development. *Genes Dev* 12:3320–3324
40. Hirose K, Morita M, Ema M, Mimura J, Hamada H, Fujii H, Saijo Y, Gotoh O, Sogawa K, Fujii-Kuriyama Y 1996 cDNA cloning and tissue-specific expression of a novel basic helix-loop-helix/PAS factor (Arnt2) with close sequence similarity to the aryl hydrocarbon receptor nuclear translocator (Arnt). *Mol Cell Biol* 16:1706–1713
41. Takahata S, Sogawa K, Kobayashi A, Ema M, Mimura J, Ozaki N, Fujii-Kuriyama Y 1998 Transcriptionally active heterodimer formation of an Arnt-like PAS protein, Arnt3, with HIF-1 $\alpha$ , HLF, and clock. *Biochem Biophys Res Commun* 248:789–794
42. Ogita T, Hashimoto E, Nakaoka T, Okabe F, Kira Y, Matsuoka R, Fujita T 1997 Hypoxia induces adrenomedullin gene expression and secretin in cultured human umbilical vein endothelial cells. *Circulation* 96:962
43. Wang X, Yue TL, Barone FC, White RF, Clark RK, Willette RN, Sulpizio AC, Aiyar NV, Ruffolo Jr RR, Feuerstein GZ 1995 Discovery of adrenomedullin in rat ischemic cortex and evidence for its role in exacerbating focal brain ischemic damage. *Proc Natl Acad Sci USA* 92:11480–11484
44. Cheung B, Leung R 1997 Elevated plasma levels of human adrenomedullin in cardiovascular, respiratory, hepatic and renal disorders. *Clin Sci (Colch)* 92:59–62
45. Ishimitsu T, Kojima M, Kangawa K, Hino J, Matsuoka H, Kitamura K, Eto T, Matsuo H 1994 Genomic structure of human adrenomedullin gene. *Biochem Biophys Res Commun* 203:631–639
46. Mishra RR, Adhikary G, Simonson MS, Cherniack NS, Prabhakar NR 1998 Role of c-fos in hypoxia-induced AP-1 cis-element activity and tyrosine hydroxylase gene expression. *Brain Res Mol Brain Res* 59:74–83
47. Cormier-Regard S, Nguyen SV, Claycomb WC 1998 Adrenomedullin gene expression is developmentally regulated and induced by hypoxia in rat ventricular cardiac myocytes. *J Biol Chem* 273:17787–17792
48. Rolfs A, Kvietikova I, Gassmann M, Wenger RH 1997 Oxygen-regulated transferrin expression is mediated by hypoxia-inducible factor-1. *J Biol Chem* 272:20055–20062
49. Levy AP, Levy NS, Wegner S, Goldberg MA 1995 Transcriptional regulation of the rat vascular endothelial growth factor gene by hypoxia. *J Biol Chem* 270:13333–13340
50. Dibbans JA, Miller DL, Damert A, Risau W, Vadas MA, Gooddall GJ 1999 Hypoxic regulation of vascular endothelial growth factor mRNA stability requires the cooperation of multiple RNA elements. *Mol Biol Cell* 10:907–919
51. Beck I, Ramirez S, Weinmann R, Caro J 1991 Enhancer element at the 3'-flanking region controls transcriptional response to hypoxia in the human erythropoietin gene. *J Biol Chem* 266:15563–15566
52. Pugh CW, Tan CC, Jones RW, Ratcliffe PJ 1991 Functional analysis of an oxygen-regulated transcriptional enhancer lying 3' to the mouse erythropoietin gene. *Proc Natl Acad Sci USA* 88:10553–10557
53. Blagosklonny MV, An WG, Romanova LY, Trepel J, Fojo T, Neckers L 1998 p53 inhibits hypoxia-inducible factor-stimulated transcription. *J Biol Chem* 273:11995–11998
54. Levy AP, Levy NS, Goldberg MA 1996 Hypoxia-inducible protein binding to vascular endothelial growth factor

- mRNA and its modulation by the von Hippel-Lindau protein. *J Biol Chem* 271:25492–25497
55. Levy NS, Chung S, Furneaux H, Levy AP 1998 Hypoxic stabilization of vascular endothelial growth factor mRNA by the RNA-binding protein HuR. *J Biol Chem* 273:6417–6423
56. Maltepe E, Schmidt JV, Baunoch D, Bradfield CA, Simon MC 1997 Abnormal angiogenesis and responses to glucose and oxygen deprivation in mice lacking the protein ARNT. *Nature* 386:403–407
57. Martin W, Villani GM, Jothianandan D, Furchgott RF 1985 Selective blockade of endothelium-dependent and glyceryl trinitrate-induced relaxation by hemoglobin and by methylene blue in the rabbit aorta. *J Pharmacol Exp Ther* 232:708–716
58. Davis LG, Kuehl WM, Battey JM 1994 *Basic Methods in Molecular Biology*, ed. 2. Appleton & Lange, Norwalk, CT
59. Montuenga LM, Mariano JM, Prentice MA, Cuttitta F, Jakowlew SB 1998 Coordinate expression of transforming growth factor- $\beta$ 1 and adrenomedullin in rodent embryogenesis. *Endocrinology* 139:3946–3957
60. Camenisch G, Tini M, Chilov D, Kvietikova I, Srinivas V, Caro J, Spielmann P, Wenger RH, Gassmann M 1999 General applicability of chicken egg yolk antibodies: the performance of IgY immunoglobulins raised against the hypoxia-inducible factor 1 $\alpha$ . *FASEB J* 13:81–88

