



Published online: 3-27-2012

“I Know This is Supposed to be More Like the Real World, But . . .”: Student Perceptions of a PBL Implementation in an Undergraduate Materials Science Course

Holly R. Henry

Andrew A. Tawfik

David H. Jonassen

Robert A. Winholtz

Sanjeev Khanna

IJPBL is Published in Open Access Format through the Generous Support of the [Teaching Academy at Purdue University](#), the [School of Education at Indiana University](#), and the [Jeannine Rainbolt College of Education at the University of Oklahoma](#).

Recommended Citation

Henry, H. R. , Tawfik, A. A. , Jonassen, D. H. , Winholtz, R. A. , & Khanna, S. (2012). “I Know This is Supposed to be More Like the Real World, But . . .”: Student Perceptions of a PBL Implementation in an Undergraduate Materials Science Course. *Interdisciplinary Journal of Problem-Based Learning*, 6(1). Available at: <https://doi.org/10.7771/1541-5015.1312>

This document has been made available through Purdue e-Pubs, a service of the Purdue University Libraries. Please contact epubs@purdue.edu for additional information.

This is an Open Access journal. This means that it uses a funding model that does not charge readers or their institutions for access. Readers may freely read, download, copy, distribute, print, search, or link to the full texts of articles. This journal is covered under the [CC BY-NC-ND license](#).

“I Know This is Supposed to be More Like the Real World, But . . .”: Student Perceptions of a PBL Implementation in an Undergraduate Materials Science Course

*Holly R. Henry, Andrew A. Tawfik, David H. Jonassen, Robert A. Winholtz,
and Sanjeev Khanna*

Abstract

This qualitative case study examines the initial implementation of a problem-based version of an undergraduate course in materials science for the purpose of identifying areas of improvement to the curriculum prior to a planned second implementation. The course was designed around problems that students work in small teams to solve under the guidance of facilitators, with early sequence problems designed to foster the problem-solving skills required to succeed in the course. This report describes students' impressions of and experiences in the course as they worked to solve the final problem at the end of the semester and compares those impressions, where applicable, to impressions gathered after they had completed the first problem near the beginning of the semester. Using grounded theory techniques to analyze the data, six central themes emerged from the implementation: course structure, facilitation roles, student roles, group processes, co-construction, and resources. Implications for practice and potential instructional design solutions that may aid in future implementations are discussed.

Keywords: PBL, engineering, undergraduate, PBL design

Introduction

Engineers, in practice, are paid to solve problems (Jonassen, Strobel, & Lee, 2006). However, the well-structured, constrained problems that engineering students solve in the classroom fail to prepare them for the complexity of ill-structured workplace problems (Henry, Jonassen, Winholtz, & Khanna, 2010). Problem-based learning (PBL) focused on authentic engineering problems may improve students' readiness to meet the demands of their future workplaces.

The following report examines the initial implementation of a problem-based version of engineering materials, an undergraduate course in materials science for mechanical engineering majors, for the purpose of identifying areas of improvement to the curriculum prior to a planned second implementation. The new course design is organized around problems, rather than topics, that students work in small teams to solve under the guidance of facilitators rather than classroom lecturers (Barrows & Tamblyn, 1980). The following qualitative case study describes students' impressions of the course as they worked to solve the final problem at the end of the semester and compares those impressions, where applicable, to impressions gathered after they had completed the first problem near the beginning of the semester (Henry, Jonassen, Winholtz, & Khanna, 2011).

PBL Implementations in Engineering Disciplines

A number of studies reporting engineering implementations of PBL have identified challenges that were experienced by the engineering student. For example, Nasr and Ramadan (2008) noted that, "The majority of students [in a thermodynamics course] are formulae-driven" (p. 22), meaning that students' tendency is to see mathematical equations as ends rather than means. They urged that "Effective methods need to be employed to discourage students from reaching out for quick equations to plug and chug in" (2008, p. 22). Similarly, Johnson (1999) reported that students in a PBL version of a hydraulic engineering course sought "homework problems to improve their understanding of fundamental calculations and help them prepare for exams" (p. 10), even though the students also complained about the added workload of PBL.

Researchers who conducted a large study of PBL courses comparing computer engineering students with those in other disciplines (Dahlgren, 2000, 2003; Dahlgren & Dahlgren, 2002) observed some differences in the engineers' perceptions of group work and their use of course objectives in their study strategies. Engineering students were more likely than those in other disciplines to see the potential for collaborative knowledge-building within their PBL teams, but they were also more confident in their ability to solve the assigned problems (Dahlgren, 2003; Dahlgren & Dahlgren, 2002). The engineering students used course objectives for self-checking their progress in the course

and for exam preparation after completing problem units, but not as guidance for solving the problems (Dahlgren, 2000).

Mitchell and Smith (2008) noted that engineering students in a third year PBL course in communications systems spent more time than instructors anticipated trying “to find new information to find a particular solution to a problem, as if it were just one discrete task, and much less in contemplating how what they were being asked built on previous knowledge and experience” (p. 136). They also found that the students’ written reports showed a tendency toward “replicating rather than applying theory” (p. 138); in other words, approaching the problems in an academic fashion rather than as practitioners. Students also complained that the grading policy did not accurately reflect what they had spent the most time on and that group grades did not account for individual contributions. As in the Dahlgren studies previously mentioned, however, the students in Mitchell and Smith’s study found teamwork to be valuable to them.

In order to succeed in a PBL setting, learners must acquire skills in the problem-solving process as well as the content of the course or unit in which the problem is situated. First-time PBL students often struggle with how to identify and learn what they need to know to solve problems without the familiar context of instructor lectures introducing those problems (Vardi & Ciccarelli, 2008). When solving ill-structured problems, the lack of familiar didactic instructional methods may overwhelm learners accustomed to such framing to direct them toward a “correct” path to success in the course or unit. For these reasons, we implemented significant scaffolding of the problem-solving processes for learners (described later in the paper).

Students must also adjust to the level of self-directed learning required of them in PBL courses as the study habits they bring from their traditional learning environments can be less effective in PBL settings (Hmelo-Silver, 2004). Even students who are successful and confident in traditional classrooms lack self-efficacy for their roles as problem-based learners (Mitchell, Smith, & Kenyon, 2005).

While working in groups is not unique to PBL, the challenges of mastering group dynamics are often a cause of concern for students in PBL implementations (Chiriac, 2008; Dolmans & Schmidt, 2006; Ochoa & Robinson, 2005). Participants cited disorganization in their group’s process, superficiality in their group’s study of the problem, and too-dominant group members as the top three hindrances to learning in one study of group dynamics in PBL (Hendry, Ryan, & Harris, 2003).

Research Questions

In order to address how effectively our PBL design met the needs of undergraduate mechanical engineering majors, we sought to answer the overall question: what changes are needed in order to improve student experiences as they transition to a PBL curriculum?

We wanted to explore student perceptions of their PBL experiences. These queries led to the following research questions:

1. What aspects of the PBL design affected student perceptions of their performance and learning by the end of the semester in this implementation?
2. How does this understanding of PBL processes inform future design?

Methodology

This descriptive case study employed grounded theory techniques (Glaser & Strauss, 1967) to analyze student perceptions about their experiences in the first PBL version of engineering materials. Since the researchers were directly involved in the design and, in some cases the delivery, of this first-time implementation, a qualitative case study approach was selected in order to explore the nature of students' experiences with the initial design of the course without limiting their expression of their perceptions to aspects of that design deemed important by the designers.

Participants

The participants in this study included 54 junior mechanical engineering majors enrolled in the spring semester of engineering materials at a large, Midwestern U.S. University. The population was largely homogenous with only two female students, two non-white students, and one student whose age fell outside of the 19-21 year old range. Students were informed that they were permitted to decline to allow their data to be used in the research and to drop the course and take it in the lecture-based format in the next semester. All students signed provided consent forms to indicate that they understood and agreed to participate in the study.

Instructional Methods

The model for the design was adapted from that used in the College of Medicine at the same University. In that program, the basic sciences curriculum, including anatomy, physiology, biochemistry, etc. has been replaced with 60 problems, each requiring a week to complete. On the first day of class, students are presented with a diagnostic problem focused on the presentation of a patient, including physical examination and patient history.

1. Students in groups of 5-8 encounter and reason through the problem. They attempt to define and bound the problem and set learning goals by identifying what they know already, what hypotheses or conjectures they can think of, what they need to learn in order to better understand the dimensions of the problem, and what learning activities are required and who will perform them.

2. During self-directed study, individual students complete their learning assignments. They collect and study resources and prepare reports to the group.
3. Students share their learning with the group and revisit the problem, generating additional hypotheses and rejecting others based on their learning.
4. At the end of the learning period (usually one week), students summarize and integrate their learning (Khanna, 2008).

Several adaptations were made from this model. Most notably, it was not possible to restructure the entire curriculum for the mechanical engineering program. In most courses in the program, professors lecture to students about the nature of the discipline and then require students to apply what they have learned to solve a problem. In this study, only the engineering materials course was redesigned to present the problem first so that students would learn the disciplinary content as they solved the problem. Because their other courses would not provide additional practice in this type of problem-solving, and because the undergraduate students would necessarily have less academic experience than the graduate students in the medical school, the implementation was planned around eight problems to allow the students two weeks to work on each. The eight problems were comprised of two types typically encountered by materials scientists: decision-making, in which students select the best material(s) to meet a specified industrial application along with any applicable materials processing methods that will alter the material in ways that meet the industrial application criteria; and troubleshooting, in which students identify a material failure mode and determine what material properties caused the failure. Problems were organized in a simple-to-complex sequence from a subject matter perspective so that students would have time to learn how to solve problems and work in teams before tackling the most challenging materials concepts (Khanna, 2008). Problems were written in story format to make them more accessible to undergraduate students (D. H. Jonassen, 2011).

Two course instructors served as facilitators for all ten student teams. The instructors had extensive prior experience teaching the course in a traditional lecture format and had previously implemented discrete problem-based assignments in courses they had taught, but had no prior experience teaching a PBL course. Instructors received PBL curriculum design assistance prior to and facilitation guidance during the implementation from the lead researcher on the project who had extensive experience in PBL implementation and research.

Students were randomly assigned to ten teams. The student teams worked through seven modules, each consisting of a single engineering problem along with supporting resources related to that problem, during the semester. For each module, teams were required to solve the given problem and collaboratively produce written reports explaining their solutions. Five problems focused on material selection and two on troubleshooting

failures. All problems included scenario narratives containing specifications that constrained material selection or detailed the materials used and the nature of the failure. Each module contained a guide that listed important subject matter concepts addressed in the problem and relevant textbook chapters covering those concepts. A variety of supplemental reading material was also provided for most problems. The first module was fully worked out as a model for students completing the remainder of the modules. It provided sample questions and answers that were relevant to the completion of the module. In this way, it demonstrated to students how to seek out the relevant conceptual material from the text, when in the process they should turn to formulae and which questions those formulae would and would not answer, and how to apply the concepts and theories from their texts to a problem.

To scaffold the problem-solving process during the first four modules, each team was required to complete a planning worksheet for each problem noting key information, learning issues, and task assignment (Appendix A). The planning sheet was designed to promote discussions within the teams in order to reflect on and articulate various aspects embedded within the problem and to plan out their work toward a solution. Students were provided basic instruction for completing the worksheet during the introductory lecture on the first day of class and directed to make it available to facilitators during each subsequent class period. Facilitators used the worksheet during the early problems to help gauge team performance and guide students toward more appropriate solution paths when they got off track. While this level of scaffolding is not normal in curriculum-wide PBL programs, it is necessary for undergraduate, PBL novices.

Several forms of additional scaffolding were provided for the first module (see Appendix B). The problem scenario modeled a mechanical engineering design team identifying the issues in the problem, sharing research tasks among their members, and collaboratively incorporating the results into a written report. The guide to the first module included flowcharts for solving both selection and troubleshooting problems and a series of questions designed to guide students through researching the first problem. The guide also presented detailed requirements for the written report and a grading rubric. After initial assessment, teams were permitted to revise and resubmit their first module reports based upon feedback received.

The group-selected leaders from all of the student teams were interviewed as they awaited their revised problem module scores by a graduate student member of the research team who had also served as an in-class observer during their work on the first problem. Analysis of the interview transcripts revealed that students were confused by the PBL structure of the course and expressed a preference for the lecture format with which they were more familiar. Students also demonstrated misconceptions about the feedback they had received, interpreting critique of their writing and report structure as more important than critique of their problem-solving methods and proposed solutions.

Two of the groups also exhibited dysfunctional group dynamics that interfered with their ability to work together to complete the problem module (Henry et al., 2011).

In response to these findings, a planned lecture was presented when the revised reports were returned to address common report shortcomings, correct misconceptions, respond to student questions, and provide a presentation about effective teamwork. Instructors attempted to more clearly emphasize critique of course content knowledge over that of writing errors in their feedback on subsequent reports; and to monitor group dynamics among student teams. Based on student needs that arose during subsequent problem modules, the instructors also implemented four additional ad hoc (unplanned) lectures, including review sessions prior to the midterm and final exams and two addressing concepts that the instructors believed students were not grasping.

Data Collection

The research team was led by a tenured faculty member in the College of Education with extensive experience in PBL research and implementation. The team included two tenured faculty members in the College of Engineering who had designed the original lecture-based format of the engineering materials course and served as the subject matter experts for the PBL design, facilitators for the PBL implementation of the course, and primary observers and evaluators of student performance in the course. Two graduate students from the College of Education served as research assistants over the course of the project, one of whom assisted with the design of the initial implementation and served as an outside observer for the first and seventh problem modules; and another who joined after the initial implementation to assist in data analysis for this report and assist with the design of the second implementation.

Researchers observed participants during their in-class meetings but not outside of class. One graduate assistant researcher collected field notes during the in-class observations and during the weekly research team meetings.

The lead researcher and the graduate student observer performed semi-structured interviews (see Appendix C) with a sample of students during their work on the final problem module (see Appendix D) in the course. Two interview subjects were selected from each team by assigning numbers to the students on the team who had not previously been interviewed and using the RANDOM function in Microsoft Excel to select from among them. One of the 16 selectees was not present in class on the day of the interview, resulting in a final sample of 15 interviews. One student's interview was discarded as it was largely unintelligible on the recordings and the interviewer's notes did not provide particular insights that were not already represented in the data. The semi-structured protocol was constructed to elucidate favorable attitudes, challenges, and opportunities for improvement. The protocol was used as a guide rather than a script in order to allow for the expression of participant perceptions not anticipated by the researchers.

Data Analysis

The purpose of the analytical techniques applied was to provide a grounded approach to establish a model (Corbin & Strauss, 2008; Glaser & Strauss, 1967; Strauss, 1987) of students' experiences of the PBL course that could be used to inform design improvements in future implementations. Participant interviews were recorded and transcribed. Interview transcripts were first analyzed by identifying units for analysis that expressed unique thoughts or ideas and having two coders independently apply open coding to each idea unit (Strauss, 1987). The open coding approach was selected to allow for the potential to find emergent themes not previously suggested by the literature. After organizing the data according to the initial set of codes from that process, coders compared the memos from their open coding to identify patterns and categories among the initial set of open codes. These patterns and categories were used to collaboratively create axial codes (Corbin & Strauss, 2008; Strauss, 1987). Axial codes were further refined into a working data dictionary by having the individual coders attempt to apply them to a random sampling of the interviews, create additional memos about how well the codes did or did not fit the interviews, and come together to negotiate the refinements. Once the coders agreed that the axial codes fit the sample interviews sufficiently, the final version of the data dictionary (see Appendix E) was used by both coders independently to apply the axial codes to all interviews. The coders then met to compare how each had applied the codes. Prior to further negotiation, both coders had agreed on the coding for 79.8% of the idea units. Following negotiation on discrepancies, the final inter-rater agreement between the two coders was 98%.

Results from the coded interviews were validated using peer debriefing and triangulation (Creswell, 2007). Findings from the interviews were discussed with the entire research team and triangulated with the observations of three researchers who observed the entire class sessions while students worked on the first and last problem modules. Observation notes from the first module had previously been analyzed using a similar open coding technique to that described above (Henry et al., 2011), as were the observation notes from the seventh problem module, though the analysis for all observation notes had been performed by a single coder. These observation notes were used for triangulation of the themes that had emerged from the coded interviews where applicable as the observation themes focused on facilitation, group dynamics, and, to a lesser degree, the use of course materials but did not expose student role or co-construction themes. Results were also compared with the results of the analysis of the earlier set of interviews in areas where common themes had persisted, however the primary purpose of this comparison was not triangulation, but rather to identify areas where student perceptions had changed.

Since the axial codes did not suggest themes unrelated to prior research in PBL implementations, several of the themes were also validated by linking them to a priori

codes suggested by the characteristics of PBL (Barrows, 1996); namely, student-centered and self-directed learning were expressed in our student role code; problem-based course organization in our course structure code; teachers as facilitators in our facilitator role code, and group-based learning in both our group dynamics and co-construction codes. Our Resources code was not represented in the Barrows characteristics as the responses there were specifically elicited in the semi-structured interview protocol to inform whether redesign of course materials might be needed. Since this was an analysis of student perceptions rather than an evaluation of student performance, we did not have sufficient data for the Barrows characteristic of problems as a vehicle for skill development to emerge.

Results

The following description of results is organized according to the axial codes described above. Relevant quotes from the interviews were extracted that both coders agreed were best indicative of the themes they are used to illustrate.

Course Structure: Lectures vs. Problems

Most students did not see a relationship between the problems and the exam content, complaining that “it wasn’t like [the exams] related back to the module[s] a whole lot” or that they “didn’t feel like what [they] did in class had anything to do with the test.” That is, PBL violated their performance and strategy scripts for being successful in undergraduate courses. Other students cited their uncertainty about exam content as a need for traditional lectures. The desire for lectures was pervasive throughout the interviews. As was the case in the earlier study (Henry et al., 2011), students still felt inadequately prepared at the end of the semester to tackle the problems without lectures, as typified by P15’s comments:

Just to give us an overview, instead of just having read the book and find out equations and definitions that we didn’t even know. Like, if they gave us just a short lecture, I think that might have been more useful. Just having a professor explain it to us than just reading it and interpreting it yourself. And it doesn’t need to be a long lecture. Just maybe a couple of examples of how it’s used and then let us apply it to the modules. I think that would be even more useful.

P15’s statement above, for example, suggests that trying to inject only a few lectures is not enough to satisfy the need that students perceive for them. Students in other traditional engineering classes receive lectures and then an assignment, but in the PBL course, when lectures were given, they were after students had already begun working on the problems,

suggesting that students perceived the lectures came at the wrong time in the process. P8 understood that the design was intended to omit lectures, but still felt that they were needed prior to the problems:

I think the problem, the problem-based learning, it can be good, but I think we need some lectures and we need to have some background as to what we're doing before we do the problem... I don't think it's a bad idea completely. But as far as seeing it in another course, I think there needs to be some background given before the problems are given... I think we absolutely need some kind of lecture before the problems are given.

P11's comments highlight that, not only did the lectures coming after the students expected them cause frustration, but that they also learned that if they waited for lectures, they would often be accommodated and get the problem module due dates extended:

The first week we just didn't understand fracture mechanics because we didn't have the lecture and it wasn't explained well in the book. It was due Thursday and it comes to class on Tuesday and no one had any work on the project done and then that Tuesday is when he comes in and it was like, "Oh, I'll give you some information and some equations," which we really needed to know. And so I was like, "You tell us two days before it's due, and this is the basis of how we design it." And so we all got really upset and pushed it back to next Tuesday, which thankfully he did.

Facilitation Roles

After completing the first problem, students did not highlight concerns about the instructors' role change from lecturer to facilitator (Henry et al., 2011). By the end of the semester, when we might have expected students to have acculturated to role changes, they actually seemed more inclined to question the role of the facilitator. For example, P2 complained:

They gave us just basically a sheet that said, "Find a new, better material; optimize the spring," and all this stuff. And we'd ask and be like, "Well, do you have any advice about where we should go?" Because we'd never done anything like this before. And they said, "Oh, you should be able to find something online or on their database."

Other participants likewise expressed this sense that the facilitators were not providing sufficient guidance. Some, like P2, were looking for more direction about how to tackle problems, with quotes such as, "what are we supposed to do from here?" and "we were

turned loose with minimal instruction.” Despite explicit directions, requirements statements, performance rubrics, feedback, and examples of good projects, other students wanted more specific answers to questions. P11, for example, expressed frustration with the way one of the facilitators used student questions to guide them to find information on their own:

It was frustrating ... because ... when we would ask him questions, [facilitator’s name omitted] only answers in questions... “We’re asking a question and I want an answer because obviously I don’t understand it.” So that’s frustrating.

Some students, such as P8, were seeking additional clarity about the instructors’ expectations rather than the answers to specific content questions:

Interpreting exactly what they want on the problem modules, because they were often vague and there wasn’t a whole lot of direction to them. There was a form on how to write the papers, but as far as what supposed to be in the paper, that wasn’t clearly defined at any point.

Concerns about grading and feedback were raised in the initial set of interviews when students were waiting for final grades on their first problem reports. At that time, students were more confident about grades because they failed to fully appreciate errors highlighted in the feedback (Henry et al., 2011). The instructors admitted that the grading and feedback required by requiring problem solving was far more demanding than that required for traditional exams. At the end of the semester, however, students were no longer confused by the content of feedback; instead, lingering uncertainty about grades was attributed to delays in getting feedback on their problem reports, as P10 exemplifies:

I think we did the first two or three modules without knowing our score on the ones before that, so we didn’t know if we were doing it right or if we were doing it wrong. So that affected the first couple of modules’ scores... We were just kind of angry about that. We didn’t know if we were doing it wrong.

Student Roles

While students experienced some discomfort with the instructor’s change of role from lecturer to facilitator in both interview sessions, the greater “culture shock” for them was the shift in their own role from instructor-directed learners to self-directed learners (Hmelo-Silver, 2004; Mitchell et al., 2005), though they did not comment on it until

the late-semester interviews. Some comments, such as P2's complaint that, "We weren't taught," reflect the passivity of the role that students expect to assume in the traditional classroom. In PBL, as P4 noticed, "Everything was solely up to you, like you were the only person that really determined whether or not you were going to understand a concept." P13 perceived the workload as overwhelming due to the lack of specific reading assignments combined with the volume of material available:

The reading materials supplied was basically the entire book, the entire Internet, thousands of supplemental pages. There was almost no way to cover it all, and studying for the test was like a shot in the dark, taking out the correct needle in the haystack of material.

These quotes correspond with those regarding the facilitator role, suggesting that students wanted the facilitator to explicitly demarcate which concepts were important for each module. In contrast, P15's group, among others, gained proficiency in learning "where to look and what was more important." Perhaps because of this improvement, P15 considered the process to be valuable: "It was good because I felt like it was useful to be able to learn on your own and I felt like I got a lot out of the reading."

Group Processes

For the first problem, students were required to adopt roles of leader and scribe within groups. Participants were instructed to rotate these duties in subsequent problems, but interviews revealed that students often ignored this suggestion. Participants noted they "kind of just went to [their] own thing" as they "found their own niche". It is possible that students may have opted to maintain the same, and thus known, roles throughout the semester to avoid perceived additional workload associated with learning additional facets of the problem-solving process.

For each module, groups were required to solve the problem and submit a report that documented justification for their selected solution, the path they took to arrive at the solution, and a "science section" that detailed underlying concepts and properties of particular materials that were relevant to the problem. P6 typified the approach most groups took toward the report:

Group discussions in class were basically how to split up the workload evenly between the group—who's going to tackle which part of the problem. Then we would go home, workout our sections. We'd meet back the day before it was due, put everything together, finalize it and turn it in.

Co-Construction

Collaborative knowledge-building is central to any PBL implementation as students take ownership of the learning process (Barrows, 1996). However, interviews revealed that students did not intentionally collaborate to teach one another about the material they were researching. Rather, co-construction emerged only on occasion and more as an incidental outcome of the collaborative work. Some participants, such as P4, suggested they did not learn from other peers because they perceived themselves on an equal knowledge level: "I really didn't talk to many other people about our problems that we were given. But a lot of us are on the same page, like if I did talk to them, they knew just as much as I did." P5 also explicitly called into question whether much could be learned from other students when s/he said, "I don't know how a student in your level of education will help you do something," and instead implied a tendency to default to the instructor rather than learn from peers:

The thing is that we go through the problem, like, together and when we have something that we are stuck with, we call the teacher and he will try to explain it. But learning from each other, I didn't see it.

Other participants noted that learning was largely focused on the portion of the report that they agreed to write. For instance, P11 described:

When we divided up the paper, it wasn't for me to learn about what they wrote about, since I didn't write about that. That kind of hindered my ability. Like, I still struggle with fracture mechanics because I never wrote about that.

This aspect may also be symptomatic of poor planning because students may not have allocated time for sharing what they were learning from their individual research tasks. P11 noted that additional structure imposed on the collaborative work would have better supported learning:

I don't think it [group work] was structured enough to have those discussions. It would have really helped if, study-wise, we had met as a group, went over the modules and said, "This is my area. I can teach you guys about it." Because I would have really liked that. So if we did a smaller group than I might have learned more because that would have done more interaction with the other persons, or had to do more work

Participant responses show that co-construction was not just embedded within groups, but also occurred across groups. P1 suggested this form of learning across groups helped to expose groups to other viewpoints and solutions within the class:

Actually talking to other groups, asking them, you know, what they thought was actually almost the most effective learning because they have a whole different, you know, viewpoint, you know, and ways to study stuff that I would say, probably, learning with other groups was as helpful as anything to me.

P11 noted that communication with other groups was not only beneficial to learning, but also pragmatic to leverage the workload:

So like for the group-to-group we would go and then we would struggle and hit a point and then go ask them and say, "Hey, have you guys figured this out?" And we would work with them that way.

Resources

While a variety of supplemental resources were provided for each module, students often reported relying largely upon "typing stuff into Google" and "a lot of Wikipedia" when solving the problems. P4 suggested that the deciphering of resources was difficult because it was the students' first experience with the content:

All the stuff on the Internet was new to us. Like very few people have had the specifics of what the modules entailed, needed to put, you know, all those specifics on. I don't know if you know what our problems were, but fracturing and how the stuff fractures. None of us had been introduced to that until now, so whatever we read was the first time we had really seen it.

This concern was expressed by multiple participants, which suggests that students may have been unclear about where and how to start the problem-solving investigation process.

Several participants expressed a need for reinforcement that the group was on the "right path." P11 found some of the supplementary resources, which included insight on how others had solved the problem, beneficial "because it was kind of nice to see extra articles on how someone else did it." P5 requested additional models to support learning:

If the teacher could give us, like, another similar problem that the people have solved or, like, professionals have solved before so we can compare our

problem to it and so we know what to write about. I mean, in my opinion, one of the best things to do for a student is to give them, like, an example for something that you say, "Okay, this the problem that professionals faced sometime in the past and that's what they came up with. So we are expecting you, as a student, to come up with something similar to that."

Discussion and Implications

Our results corroborate previous research that suggests that learners struggle to adapt to the problem-solving process without the familiarity of instructor directed lectures (Vardi & Ciccarelli, 2008). PBL requires developing substantially new learning strategies for the students, including self-reliance and independent study skills, an effort that most of these undergraduate students seemed unable or unwilling to make. Their comments suggest that students were still uncomfortable with their role change toward self-directed learning and the instructors' role change from lecturer to facilitator. The decision to respond to student concerns and learned helplessness on particular problems by providing ad hoc lectures not only reduced students' ability to adjust to the demands of self-directed learning, but also interfered with the course schedule and the instructors' own role adjustment as the students learned to manipulate them into taking on their own more familiar roles as lecturers.

These role adjustment issues may have hindered student learning, and almost certainly affected student self-efficacy. By the end of the semester, we would have expected students to have a much clearer understanding of how to approach new problems and what level of performance was expected of them. After the first problem, students were somewhat overconfident about their ability to meet expected performance demands as they failed to apprehend the most significant aspects of the feedback that they had received (Henry et al., 2011). At the end of the semester, they expressed more uncertainty about what was expected of them and noted that they did not receive feedback from one problem module in time to improve their performance on the next. Improved timeliness of feedback might help students improve their performance by repairing misconceptions in their learning (Hattie & Timperley, 2007) in time to apply them to subsequent problem modules.

This is not to suggest that students perceived their PBL experiences as completely negative. Despite their almost universal perception that more lectures would help them learn better, many participants also reported enjoying problem-solving activities more than lectures. There was even some indication that the students, who were admittedly used to "solving equations," and "doing calculations" were beginning to appreciate formulae as tools. P15 expresses this recognition:

In a different class I would learn how to calculate things, but this class I would know how to select a material for a certain purpose and not so much calculate about the material.

Recalling Nasr and Ramadan's (2008) concern that engineering students tend to be "formulae-driven," such growth in the ability to focus on how equations will be used suggests that the problems incorporated in this design were well-contextualized and of sufficient complexity to reduce students' "reaching out for quick equations to plug and chug in" (p. 22).

In our earlier study (Henry et al., 2011), two of the student groups reported troubling levels of group dysfunction after completing the first problem. Rather than changing group composition (with one exception in which a group became too small after one member dropped the course), facilitators were advised to watch for and provide guidance on problems with group dynamics. Since students spent a considerable amount of time over the course of the semester working together and working out their differences, the authors are unable to determine whether facilitator actions in particular had a significant impact on group dynamics. However, by the end of the semester, the reported issues from the two groups highlighted in the earlier report were no longer demonstrated in the second round of interviews.

Knowledge co-construction among peers should support collaborative elements such as building on contribution, argumentation, and peer questioning (Chi, 2009). However, the participants' responses suggest that, while elements of co-construction were found within the groups, it was infrequent and not systematic. As cited in previous research (Hendry et al., 2003; Nasr & Ramadan, 2008), the results reveal that most groups did little organization and planning of their work. Instead, they simply "split the work up." This characterization often accompanied complaints of increased workload demands associated with PBL, suggesting that, if students had a better understanding of how to employ class time and group scheduling, it might have made the workload seem more manageable.

Another reason that students may have had difficulty organizing their group work was the perceived lack of a planning tool or shared space. Participants noted they used various means to manage the work, but often had difficulty with the chosen medium. As P5 expressed, "Someone would write something and send it out in emails, but then you don't know if that person ever got it and opened it." Similarly, when asked how the group devised strategies for completing tasks, P9 responded, "We would just mass mail it out to everybody and then somebody would end up doing it. It was just kind of weird how it worked out," suggesting that report creation was more fortuitous than a result of systematic group problem-solving.

Student responses implied that the extra scaffolding provided in the first problem module was not enough to help to establish deliverable requirements and set expectations of the problem-solving activities the groups are required to perform. As a result, additional models may alleviate some of the self-directed learning confusion and apprehension (Coll, 2006) that tend to occur within initial introductions to PBL and to provide opportunity for summative reflection, as P5 requested, "I'd be glad if we could have some other examples like real examples in the class so we can, like, tie up the material that we are studying right now with real examples." Such models of problem-solving may thus also fortify concepts from the problems after the problem-solving process.

Recommendations and Directions for Future Research

The purpose of this study was to consolidate recommendations for the next implementation of the PBL curriculum in Engineering Materials based upon our results. While a case study cannot be considered broadly generalizable, these recommendations may represent areas for future design-based research by other design practitioners experiencing similar issues in their implementations. The recommendations are organized according to the major themes that emerged from our analysis.

Course Structure

Among students, there was a complete disconnect between the problems they solved and the examinations they completed. The examinations were traditional, so students used different strategies to solve the problems than they did to the study for the examinations. In subsequent implementations, the examinations will be eliminated, and quizzes focusing on conceptual issues related to the problem just completed will be used to assess student understanding along with the project reports.

Changing the style of assessment alone may reduce demand for lectures. However, based upon both student responses demonstrating a desire for more content-based lectures and instructor feedback that some topics are very difficult to grasp, we have recommended repository of "lecturettes," defined as short (5-10 minute), single-topic recorded lectures available to students on demand that focus on the conceptual issues involved in each problem. This would allow lectures to function in the same way that the textbook and other resources do in the current design: as performance tools to support problem-solving that learners could choose to access if and when they feel the need for such support in keeping with the principle of self-directed learning.

We also recommend adding whole-class debriefing discussions after each problem to provide an opportunity for students to get answers to outstanding questions and to check their understanding of the course content raised in the problem while allowing instructors to guide discussion in such a way as to clear up any common student miscon-

ceptions related to the problem. Such a session could alleviate complaints about lack of timely feedback, help students better prepare for exams, promote student reflection, and strengthen analogical transfer of the structural characteristics of the completed problem to future problems.

Group Processes

Groups expressed some difficulty in organization, planning, and scheduling of their work. This could be alleviated by setting milestones and interim deliverables, particularly to serve as scaffolding on early problems. However, such techniques would add to the grading load and might reduce student autonomy in directing their own learning. Facilitators could place more emphasis on mentoring students on these skills. Additional tools, such as group calendaring or project management software, could also assist students to plan and coordinate their problem-solving activities.

Co-Construction

In general, students did not demonstrate significant learning from one another. Many of the interview participants constrained themselves to the parts of the reports that they had written. Further, once they had established them, group members rarely switched roles. While scheduling or project management tools may help student teams create time for co-construction activities, additional support is needed to promote collaborative knowledge-building. In the next implementation of the course, we have implemented collaborative Wikis, where students collaboratively address conceptual questions as well as procedural issues related to the problem and completion of the report. A wiki can serve as such support by allowing artifact sharing, collaborative document construction, and discussion in a centralized repository (Larsson & Alterman, 2009). In the revised implementation, students do their initial collaboration on project reports in a wiki to expose their in-process construction to facilitators who can use it to guide students' progress. Such a space may also help eliminate some of the difficulties of managing the project and allow students to better focus efforts on problem-solving.

Problems used in the course should allow multiple acceptable solutions. The availability of multiple valid solutions promotes argumentation among students, which is a key mechanism for co-construction. Additionally, the facilitators could invite student teams to present competing solutions at post-mortem sessions to promote cross-group co-construction. Because student roles in PBL change significantly, it is essential to provide extensive scaffolding to undergraduate students for whom this is a novel method of studying.

Analogous Problems

Several participants expressed a desire for examples of how other experts might have solved similar problems. A case library, including not only written reports, but interviews of practitioners from industry and academia, could provide examples of how other have solved similar problems (Hernandez-Serrano & Jonassen, 2003; Jonassen & Hernandez-Serrano, 2002; Kolodner, Owensby, & Guzdial, 2004). We plan to construct a case library of problems that have been solved in the field to allow students to compare and contrast alternative problem-solving methods. It is important that these cases be indexed so that recommendations of specific problems can be made to students to assist them in understand in the issues in each problem that they solve.

Summary

PBL places significant demands on student learning, especially when it is a new instructional methodology for them. The most successful PBL programs are those that are used across the entire curriculum, so that students develop and apply those strategies throughout their learning experiences. In most university curricula in the U.S., that would require a level of change that is improbable. There exist universities (Aarlborg in Denmark and Olin College in the U.S.) where curricular PBL programs have been implemented. However, for engineering faculties that want to experiment with PBL in individual courses for the first time, it is imperative that they provide higher levels of structure and scaffolding than may be operative in many PBL programs.

Acknowledgments

This material is based upon work supported by the National Science Foundation under Grant No. DUE-0836914. Any opinions, findings, and conclusions or recommendations expressed in this material are those of the author(s) and do not necessarily reflect the views of the National Science Foundation.

References

- Barrows, H. S. (1996). Problem-based learning in medicine and beyond: A brief overview. *New Directions for Teaching and Learning*, 1996(68), 3-12. doi:10.1002/tl.37219966804
- Barrows, H. S., & Tamblyn, R. M. (1980). *Problem-based learning: An approach to medical education*. New York: Springer.
- Budinski, K. G., & Budinski, M. K. (2002). *Engineering materials: Properties and selection* (7th ed.). Upper Saddle River, NJ: Prentice Hall.

- Chi, M. T. H. (2009). Active-constructive-interactive: A conceptual framework for differentiating learning activities. *Topics in Cognitive Science, 1*(1), 73-105. doi:10.1111/j.1756-8765.2008.01005.x
- Chiriac, E. H. (2008). A scheme for understanding group processes in problem-based learning. *Higher Education, 55*(5), 505-518. doi:10.1002/tl.37219966804
- Coll, R. K. (2006). The role of models, mental models and analogies in chemistry teaching. In J. Aubusson, A. G. Harrison & S. M. Ritchie (Eds.), *Metaphor and Analogy in Science Education* (Vol. 30). Berlin/Heidelberg: Springer-Verlag. doi:10.1002/tl.37219966804
- Corbin, J., & Strauss, A. (2008). *Basics of qualitative research* (3rd ed.). Thousand Oaks, CA: Sage Publications.
- Creswell, J. W. (2007). *Qualitative inquiry and research design: Choosing among five approaches* (2nd ed.). Thousand Oaks, CA: Sage Publications.
- Dahlgren, M. A. (2000). Portraits of PBL: Course objectives and students' study strategies in computer engineering, psychology and physiotherapy. *Instructional Science, 28*(4), 309-329. doi:10.1002/tl.37219966804
- Dahlgren, M. A. (2003). PBL through the looking-glass: Comparing applications in computer engineering, psychology and physiotherapy. *The International Journal of Engineering Education, 19*(5), 672-681.
- Dahlgren, M. A., & Dahlgren, L. O. (2002). Portraits of PBL: Students' experiences of the characteristics of problem-based learning in physiotherapy, computer engineering and psychology. *Instructional Science, 30*(2), 111-127. doi:10.1023/A:1014819418051
- Dolmans, D. H., & Schmidt, H. G. (2006). What do we know about cognitive and motivational effects of small group tutorials in problem-based learning? *Advances in Health Sciences Education, 11*(4), 321-336. doi:http://dx.doi.org/10.1007/s10459-006-9012-8
- Glaser, B., & Strauss, A. (1967). *The discovery of grounded theory: Strategies for qualitative research*. Hawthorne, NY: Aldine de Gruyter.
- Hattie, J., & Timperley, H. (2007). The power of feedback. *Review of Educational Research, 77*(1), 81-112. doi:10.3102/003465430298487
- Hendry, G. D., Ryan, G., & Harris, J. (2003). Group problems in problem-based learning. *Medical Teacher, 25*(6), 609-616. doi:10.1080/0142159031000137427
- Henry, H., Jonassen, D. H., Winholtz, R. A., & Khanna, S. (2010, November 12-18). *Challenges of introducing problem-based learning in a materials science course in the undergraduate engineering curriculum*. Paper presented at the ASME 2010 International Mechanical Engineering Congress & Exposition, Vancouver, Canada.
- Henry, H., Jonassen, D. H., Winholtz, R. A., & Khanna, S. (2011, April 9). "We kind of got pushed off into the deep end": PBL in undergraduate engineering. Paper presented at the annual meeting of the American Educational Research Association, New Orleans, LA.
- Hernandez-Serrano, J., & Jonassen, D. H. (2003). The effects of case libraries on problem solving. *Journal of Computer Assisted Learning, 19*(1), 103-114. doi:10.1046/j.0266-4909.2002.00010.x
- Hmelo-Silver, C. (2004). Problem-based learning: What and how do students learn? *Educational Psychology Review, 16*(3), 235-266. doi:10.1046/j.0266-4909.2002.00010.x

- Johnson, P. A. (1999). Problem-based, cooperative learning in the engineering classroom. *Journal of Professional Issues in Engineering Education and Practice*, 125(1), 8. doi:10.1061/(ASCE)1052-3928(1999)125:1(8)
- Jonassen, D. H. (2011). *Learning to solve problems: A handbook for designing problem-solving learning environments*. New York: Routledge.
- Jonassen, D. H., & Hernandez-Serrano, J. (2002). Case-based reasoning and instructional design: Using stories to support problem solving. *Educational Technology Research and Development*, 50(2), 65-77. doi:10.1007/BF02504994
- Jonassen, D. H., Strobel, J., & Lee, C. B. (2006). Everyday problem solving in engineering: Lessons for engineering educators. *Journal of Engineering Education*, 95(2), 139-151.
- Khanna, S. (2008). *Effectiveness of problem-based learning in a materials science course in the engineering curriculum*. NSF Grant Proposal. University of Missouri. Columbia, MO.
- Kolodner, J. L., Owensby, J. N., & Guzdial, M. (2004). Case-based learning aids. In D. H. Jonassen (Ed.), *Handbook of research on educational communications and technology* (Second ed., pp. 829-861). Mahwah, NJ: Lawrence Erlbaum Associates, Inc.
- Larusson, J. A., & Alterman, R. (2009). Wikis to support the "collaborative" part of collaborative learning. *International Journal of Computer-Supported Collaborative Learning*, 4(4), 371-402. doi:10.1007/s11412-009-9076-6
- Mitchell, J. E., & Smith, J. (2008). Case study of the introduction of problem-based learning in electronic engineering. *International Journal of Electrical Engineering Education*, 45(2), 131-273.
- Mitchell, J. E., Smith, J., & Kenyon, A. J. (2005). "It's not for lazy students like me. . ." *International Journal of Electrical Engineering Education*, 42(1), 41-51.
- Nasr, K. J., & Ramadan, B. H. (2008). Impact assessment of problem-based learning in an engineering science course. *Journal of STEM Education: Innovations & Research*, 9(3/4), 16-24.
- Ochoa, T. A., & Robinson, J. M. (2005). Revisiting group consensus: Collaborative learning dynamics during a problem-based learning activity in education. *Teacher Education and Special Education*, 28(1), 10-20. doi:10.1177/088840640502800102
- Strauss, A. L. (1987). *Qualitative analysis for social scientists*. Cambridge: Cambridge University Press. doi:10.1017/CBO9780511557842
- Vardi, I., & Ciccarelli, M. (2008). Overcoming problems in problem-based learning: A trial of strategies in an undergraduate unit. *Innovations in Education and Teaching International*, 45(4), 345-354. doi:http://dx.doi.org/10.1080/14703290802377190

Holly R. Henry is an instructional designer at the University of Missouri System and a doctoral candidate in the School of Information Sciences and Learning Technologies at the University of Missouri. Henry earned her MA in Instructional Technology and Media from Teachers College Columbia University and has previously worked as a faculty trainer at New York University and as a technical trainer and information technology professional at Hewlett-Packard and Procter and Gamble. Her research interests include problem solving, fostering argumentation, student engagement in distance and online education programs, and training novices to develop expertise. Correspondence concerning this article should be addressed to Holly R. Henry, 310 Clark Hall, Columbia, MO 65211; E-mail: henryh@umsystem.edu.

Dr. Andrew A. Tawfik is an assistant professor of Instructional Design and Technology at Concordia University Chicago where he serves as an instructor of educational technology. He earned his PhD in Learning Technologies from the University of Missouri. Tawfik's research interests include problem-based learning, case-based reasoning, case library instructional design, and computer-supported collaborative learning.

Dr. David H. Jonassen is Curators' Professor at the University of Missouri where he teaches in the areas of Learning Technologies and Educational Psychology. Since earning his doctorate in educational media and experimental educational psychology from Temple University, Jonassen has taught at the University of Missouri, Pennsylvania State University, University of Colorado, the University of Twente in the Netherlands, University of North Carolina at Greensboro, and Syracuse University. He has published thirty-five books and hundreds of articles, papers, and reports on text design, task analysis, instructional design, computer-based learning, hypermedia, constructivism, cognitive tools, and problem solving. His current research focuses on the cognitive processes engaged by problem solving and models and methods for supporting those processes during learning, culminating in a book, *Learning to Solve Problems: A Handbook for Designing Problem-Solving Learning Environments*.

Dr. R. A. Winholtz is an associate professor of Mechanical and Aerospace Engineering at the University of Missouri. He earned his PhD in Materials Science and Engineering at Northwestern University and has been at the University of Missouri since then. He has twenty-four refereed journal publications and three book chapters. He has been a Visiting Scientist at Argonne National Lab, a National Research Council Fellow at the Air Force Office of Scientific Research, a Visiting Scholar at Dalian Maritime University, and a Visiting Professor at Thai Nguyen University of Technology. Current research interests include neutron imaging of oscillating heat pipes.

Dr. Sanjeev K. Khanna is a La Pierre Professor in the Mechanical and Aerospace Engineering Department and Assistant Director of the Missouri Industrial Assessment Center at the University of Missouri. His teaching and research interests are in materials science, materials characterization, manufacturing and design, energy efficiency, and developing new pedagogical approaches in the engineering curriculum. Khanna received his doctorate in mechanical engineering and applied mechanics from the University of Rhode Island, and he has taught at the University of Missouri and South Dakota School of Mines and Technology. He has published articles and a textbook, *Mechanics of Materials: A Modern Integration of Mechanics and Materials in Structural Design*, which develop methods to integrate teaching of traditionally disparate subjects such as materials science, mechanics, and design and manufacturing in engineering. His current interest focuses on introducing problem-based learning in engineering design courses.

Appendix A: PBL Planning Form

Team Name: _____

Facts/What We Know	Performance/Material Properties	Learning Issues	Action Plan

What information is relevant to the material selection? How is it related to each other?

What performance characteristics and material properties are needed?

How do we determine those properties and how to represent them mathematically?

What do we have to do to figure out how to solve the problem and who is responsible for finding that out?

Appendix B: Problem Module 1

The following problem is based on an example given by Budinski and Budinski (2002).

1. The Problem to Solve

Directions: Read the Problem. Note the important information in the problem statement.

Groby Industries designs and manufactures x-ray equipment for hospitals and laboratories. Lately, management has become dissatisfied with its market share for the x-ray cassettes used by its hospital customers. Groby has recently been undercut in the market because its closest rival has found a way to produce the cassettes more cheaply. Rather than simply cutting production costs to compete on price, management prefers to improve Groby's existing x-ray cassette design. X-ray cassette

The VP of the design department at Groby has tapped senior design engineer Alex Sparks to manage the project. Alex is meeting with four other engineers in the design department to discuss how to approach the problem.

"Okay, guys," Alex begins, "the marketing department did a customer survey and found out that their biggest complaint about our x-ray cassettes is that they are too heavy. The x-ray technicians at the hospitals handle a lot of cassettes during their shifts. They said that, in addition to positioning patients, transporting the x-ray cassettes is the most physically demanding part of the job. Our VP says that the best way to increase our sales would be to make the cassettes lighter."

Jocelyn replies, "Okay, since I'm new to Groby, I just want to check my understanding here. The cassettes hold the film while the x-ray is being taken, right?"

"That's right, Jocelyn," Alex replies. "It's very important that any solution we propose will still hold the film rigidly in place during patient exposure. It also can't allow any light to get to the film."

"If the cassette is light-tight, how does the film get exposed?" Jocelyn wonders aloud.

"On the inside of each cassette, there is a scintillating material that produces light when exposed to x-rays," Alex explains. "This is how the film gets properly exposed by the x-ray machine."

Charlie, another member of the team, has worked extensively on the design of Groby's biggest selling x-ray machine, though he was not directly involved with designing the current cassettes used in it. "Let's not forget," he interjects, "the re-designed cassettes still have to work with the machine itself. They must have the same width of 500 mm and height of 400 mm or they won't fit right in the machine."

"Well, if we just want to make the cassettes lighter," suggests Zac, "couldn't we just make the face plates thinner? They're pretty dense, right?"

"The plates are currently 0.5 mm thick," replies Sunil, who was the lead designer for the current cassettes.

Charlie adds, "As long as the width and height of the cassette remains the same, there should be no problem with making them thicker or thinner within reason, at least in terms of how they will fit in the machine."

"Sure, Charlie," Sunil continues, "but we won't be able to move in a direction that requires increasing a patient's exposure to get the same exposure on the film. We also have to keep the rigidity of the current plates."

"How would a patient get a higher exposure, Sunil?" asked Charlie.

"If the new plates absorb x-rays more than the current design, the patient will have to receive a higher exposure to get the same amount of exposure on the film."

"Does that mean we can reduce the patient exposure if we select a material that absorbs less than the current design?" asked Jocelyn.

"Yes, it does," replied Sunil, "but the current design is transparent enough to x-rays that it probably won't make much difference. The lawyers would never let us move in the other direction though."

"@!#\$%^&@^ lawyers!" they all mumbled under their breath in unison.

Jocelyn asks, "What material are we using to make the plates now?"

Sunil replies, "An aluminum alloy."

"Sunil and Charlie raise some good points," Alex says. "Let's also remember that our new plate design is required to have similar or lower deflections and a reasonable amount of toughness and strength."

"So how do we get started, Alex?" Zac inquires.

"I think we need to look at different materials as well as the possibility of just making the current plates thinner," Alex replies.

"I can use our database to find alternative materials that might work," says Jocelyn, "but that's not going to tell me what impact they might have on patient exposure to x-rays."

"Since I worked on the original cassette design, I have some reference materials about x-ray dose we can use," Sunil tells Jocelyn. "Alex, I can be responsible for evaluating potential designs for dose considerations. I'll set up a spreadsheet for the calculations for different materials and when you finalize potential thicknesses, I can calculate the absorption."

"Great," says Alex. "What else?"

"I'll work on the numbers for the different materials, including the current aluminum alloy, at different thicknesses so we can compare them," Zac replies.

"I can be the quality control engineer," says Charlie, "and review the designs to make sure they will work right with the x-ray machine."

“This sounds good. I will make a project plan for our team to complete the work. Management wants a proposal for the redesign by Monday. I need you to let me know right away if you are going to have trouble meeting your deadlines for your tasks. Let’s meet the day after tomorrow and talk about what we’ve found.”

“So you’ll write the proposal, Alex?” asks Jocelyn.

“I’ll prepare the final version,” Alex responds, “but we all need to contribute to the proposal. We will need to explain our material choice, along with other design considerations such as the thickness we’ll propose, and demonstrate that our new design will result in a lighter cassette that works with the existing equipment and produces no greater exposure to patients. Everyone has a piece of that information, so we’ll need to work as a team to put it all together.”

2. How to Approach this Problem

Directions: Analyze the problem by completing each of these tasks.

1.
 - A. Determine performance problem (e.g., cassettes too heavy, cause injury)
 - B. Determine performance goal (e.g., modify cassette to be lighter, non-toxic, with same functionality)
 - C. Determine performance characteristics (e.g., lighter, stronger, faster, bending stiffness, x-ray transmission) for job
 - D. Identify solution options (e.g., substitute material with lower density, use less material)

2. For each performance characteristic, determine the material properties that affect that performance
 - a. Repeat until done:
 - i. Identify primary material properties (elastic modulus, density, x-ray attenuation) that affect/control each requirement
 - ii. Identify secondary material properties (e.g., fracture toughness, compatibility with people, poison danger) that affect/control each requirement
 - iii. Identify and map the factors that affect that property and the factors that will be affected by that property and how they are affected (see Figure 1)
 - iv. Which properties require a limiting value for the application? (e.g., fracture toughness must be at least 10 MPa√m)

- vi. Which properties should be optimized (maximized, minimized)? (e.g., minimizing the density can minimize the weight, all else being equal)
 - vii. Rank properties in terms of importance
 - viii. Determine interactions among requirements (e.g., density and elastic modulus cannot be varied independently with materials. Increasing thickness to increase stiffness increases the weight. You can find that the maximum $E^{1/3}/\rho$ minimizes weight)
 - b. Determine final ranked property list
3. Explain microstructural origin of required material properties: How are material properties achieved in the material? The paradigm illustrated in Figure 2 will help in considering the origin of the properties.
4.
 - a. Identify class of materials that should meet those properties
 - b. Select 5-10 candidate materials from a database or other sources (see Appendix A)
5. Select equation(s) and calculate changes to material performance for each alternative
6. Does material need to be processed to achieve the desired properties? (see Appendix B)
 - 6a. If yes, develop material processing necessary to meet the desired/required material properties.
7. Examine candidate materials in greater detail
8. Determine pros and cons for candidate materials
9. Develop argument in favor of final choice
10. Develop counter arguments against materials not chosen
11. Iterate between 9 and 10, change choice if necessary.

Figure 1. Face plate material properties' affect on the performance of the x-ray cassette

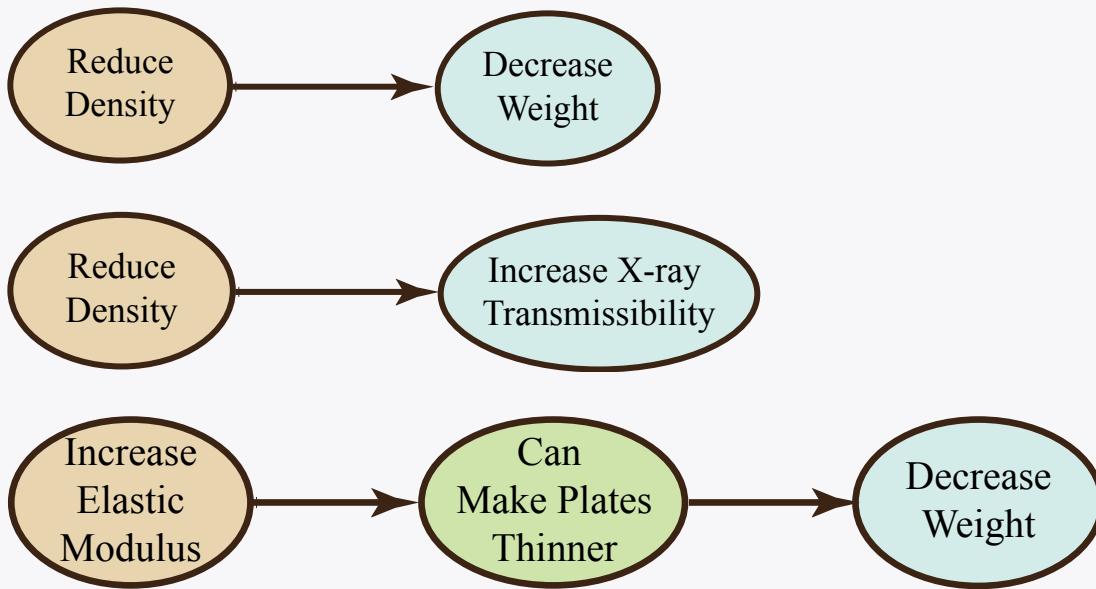
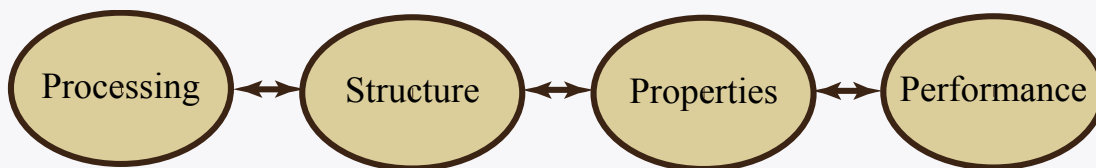

Figure 2. Paradigm for understanding the materials science behind the properties of materials which affects their performance.



3. Write a Report

Directions: Working with your team members, write a report that argues for the best material and complies with the MAE 3200 Writing Assignment Requirements.

1. State the specific performance problem inferred from the problem statement.
 - a. List all performance characteristics that are required of the x-ray cassette using appropriate descriptors and describe how each characteristic is achieved.
 - b. Describe how each of these performance characteristics may interact and the implications for material design.

- c. Rank each performance characteristic in terms of importance to the problem.
2. For each performance characteristic described in Step 1, state all primary and secondary material properties affecting that performance
 - a. For each material, describe the physical factors and their effects on the material property.
 - b. Describe any and all interactions among the material properties that you have described.
 - c. Identify appropriate equations for quantifying performance characteristics and material properties and use them to calculate material properties.
 - d. Calculate all changes to material properties from a baseline.
 3. Identify all candidate materials.
 4. Select the most appropriate material and use case evidence and calculation to argue why your selection is the best material to select.
 5. For other candidate materials, argue for why they are less effective solutions to the problem.

6. Since this is an academic course, include a science section where the materials science principles behind the materials and their properties are explained.

Your report must be written according to these Writing Assignment

Requirements:

- Your work should be fully word-processed (text, equations, tables, and figures) so it could be transmitted electronically.
- Produce a single electronic document. Do not produce separate documents for different parts of the report (e.g., figures or references).
- For the final submission, in addition to a paper copy turned in by the deadline, an electronic copy must be submitted through Blackboard.
- All aspects of your reports should be consistent with the *Mechanical Engineering Technical Communications Stylebook*.
(<http://www.missouri.edu/~mae/students/stylebook.pdf>.)
- Use 12 point New Times Roman font for all the main text.
- Include an abstract.
- Your reports should be double-spaced to facilitate commentary by the instructor.

- Use a spell checker. A spell checker cannot guarantee the correct usage of all the words but it will help you a great deal. A grammar checker can also provide useful suggestions.
- You should cite information you have obtained from books, journals, web sites, and personal communications with a reference list conforming to the Mechanical Engineering Stylebook.
- The first citation of a reference should come in numerical order (i.e., start with [1] for the first reference encountered in reading the report, [2] for the second unique one, and so forth.)
- Each assignment should be the product of your own research, study, and thoughts, expressed in your own words, except where references acknowledge the use of other sources. While discussing your assignment with others is one of the best methods to learn, your discussions should not violate these principles. Any plagiarism will be referred to the Provost's office for disciplinary action.
- Unless otherwise informed, you are writing to a technically literate audience, such as your classmates in engineering. You don't have to explain elementary science, mathematics, or engineering principles. Reports should not be aimed at an expert either. You may have to take the time to thoroughly understand your primary sources and simplify the concepts so that your classmates can understand them.
- You should look for calculations and figures that you can present to illustrate and/or support your arguments. These assignments are more open-ended than you are used to. This means they are more like the problems you will face outside academia or in it if you pursue an advanced degree.
- Resources to help you in writing reports can be found at the Campus Writing Program homepage: <http://cwp.missouri.edu/>.

4. Assessing Your Reports

For each criterion, we will assign the statement and value that best describes the quality of your report. The first submission and final submission of a report will each count for 50% of the final score for that assignment.

Determination of performance problem

- 3 All performance characteristics of problem (e.g., weight, speed, structural strength, thickness, stiffness, higher or lower temperature) identified; all characteristics relevant to problem
- 2 Most performance characteristics identified; all relevant to problem

- 1 Only a few performance characteristics identified; some not relevant to problem
- 0 No performance characteristics identified

Required performance characteristics:

- 4 All performance characteristics stated using appropriate descriptors (e.g., lighter, stronger, faster, bending stiffness, x-ray transmission)
 - 3 Most performance characteristics stated, all with appropriate descriptors
 - 2 Most performance characteristics stated, some with appropriate descriptors
Few performance descriptors stated
 - 0 No performance descriptors stated
-
- 2 Range of performance characteristics appropriate
 - 1 Range of performance characteristics inaccurate (too many or too few characteristics described)
-
- 3 Ranking of performance characteristics to be maximized or minimized by material selection are appropriate to task.
 - 2 All performance characteristics stated but improperly ranked
 - 1 Performance characteristics and ranking inappropriate

Material properties (for each performance characteristic)

- 3 All primary and secondary material properties identified for each performance characteristic
 - 2 Most primary and secondary material properties identified for each performance characteristic
 - 1 Some primary and secondary material properties identified for each performance characteristic
 - 0 No primary and secondary material properties identified for each performance characteristic
-
- 3 All physical factors and their effect on material properties stated
 - 2 Most physical factors and their effect on material properties stated
 - 1 Some physical factors and their effect on material properties stated
 - 0 No physical factors and their effect on material properties stated
-
- 2 Ranking of material properties in order of importance
 - 1 All materials properties ranked; some out of order out of order
 - 0 No ranking of material properties

Interactions among material properties on performance stated correctly

3 All interactions among material properties on performance stated correctly (e.g., increasing the thickness will increase the stiffness but may increase the weight)

2 Most interactions among material properties on performance stated correctly

1 Some interactions among material properties on performance stated correctly

0 No interactions among material properties on performance stated correctly

3 All interactions among material properties and performance correctly quantified using

appropriate equations

2 All interactions among material properties stated but equations are not all accurate

1 Some interactions among material properties and *performance* correctly quantified

using appropriate equations

0 No interactions among material properties correctly quantified using appropriate

equations

For specific material selected:

3 Correct calculation of changes from a baseline

2 Partially correct calculation of changes from a baseline

1 Inaccurate calculation of changes from a baseline

0 No calculation of changes from a baseline

2 All important advantages of material stated to justify selection

1 Some important advantages of material stated to justify selection

0 No important advantages of material stated to justify selection

3 Rebuttals to alternative materials provided listing appropriate material properties and interactions

2 Rebuttals to alternative materials provided but missing some material properties and interactions

1 Rebuttals to alternative materials provided with inappropriate justification

0 No rebuttals provided

Science Section

- 4 Relevant materials science principles identified and correctly explained
- 3 Most material science principles identified and correctly explained
- 2 Significant materials science principles omitted or inaccurately explained
- 1 Science section completely misses relevant issues in the problem
- 0 Science section omitted

Report Writing

- 4 Completely and consistently follow MAE 3200 Report Writing Requirements
- 3 Usually follows MAE 3200 Report Writing Requirements with some exceptions
- 2 Inconsistently follows MAE 3200 Report Writing Requirements
- 1 Very rarely follows MAE 3200 Report Writing Requirements

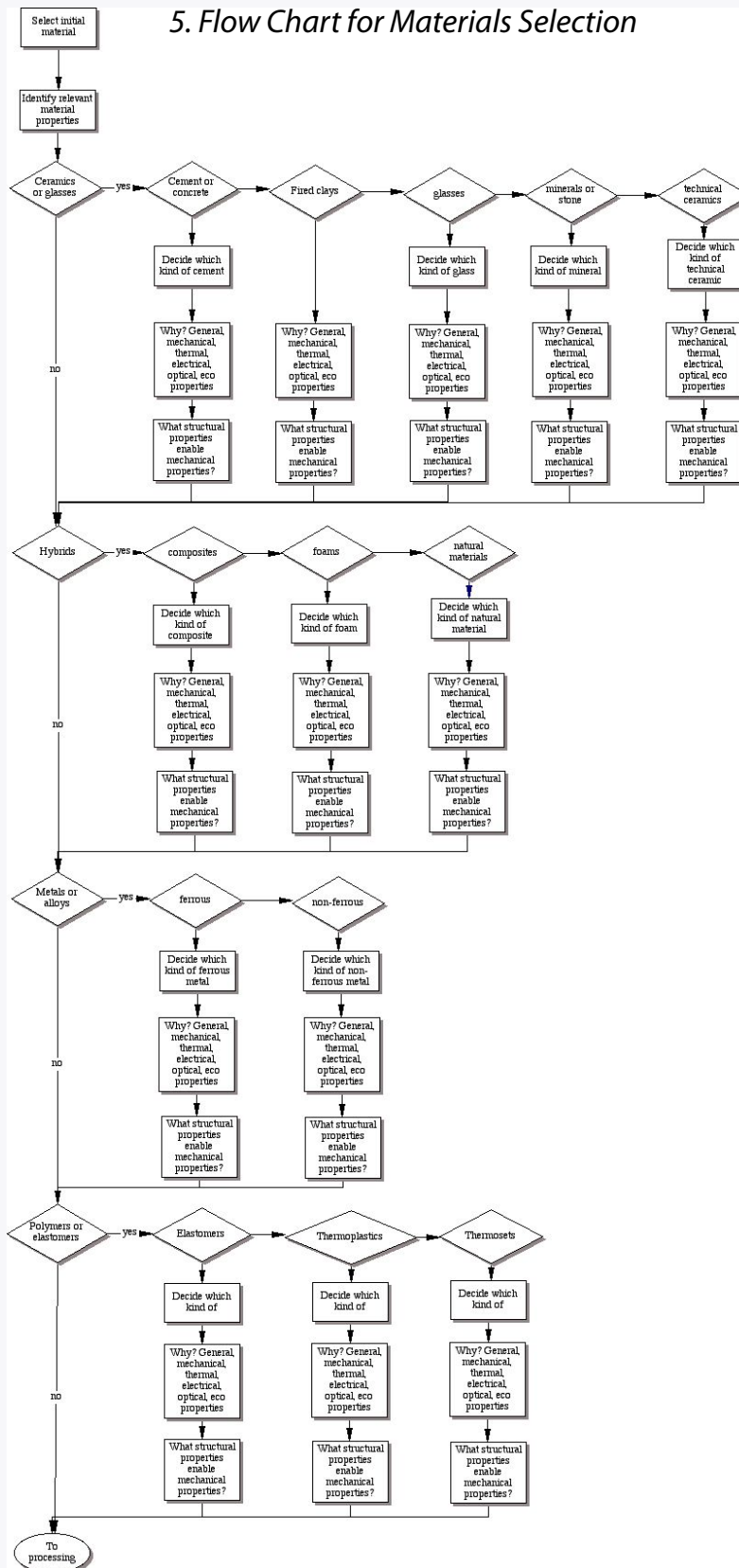

6. Flow Chart for Materials Processing

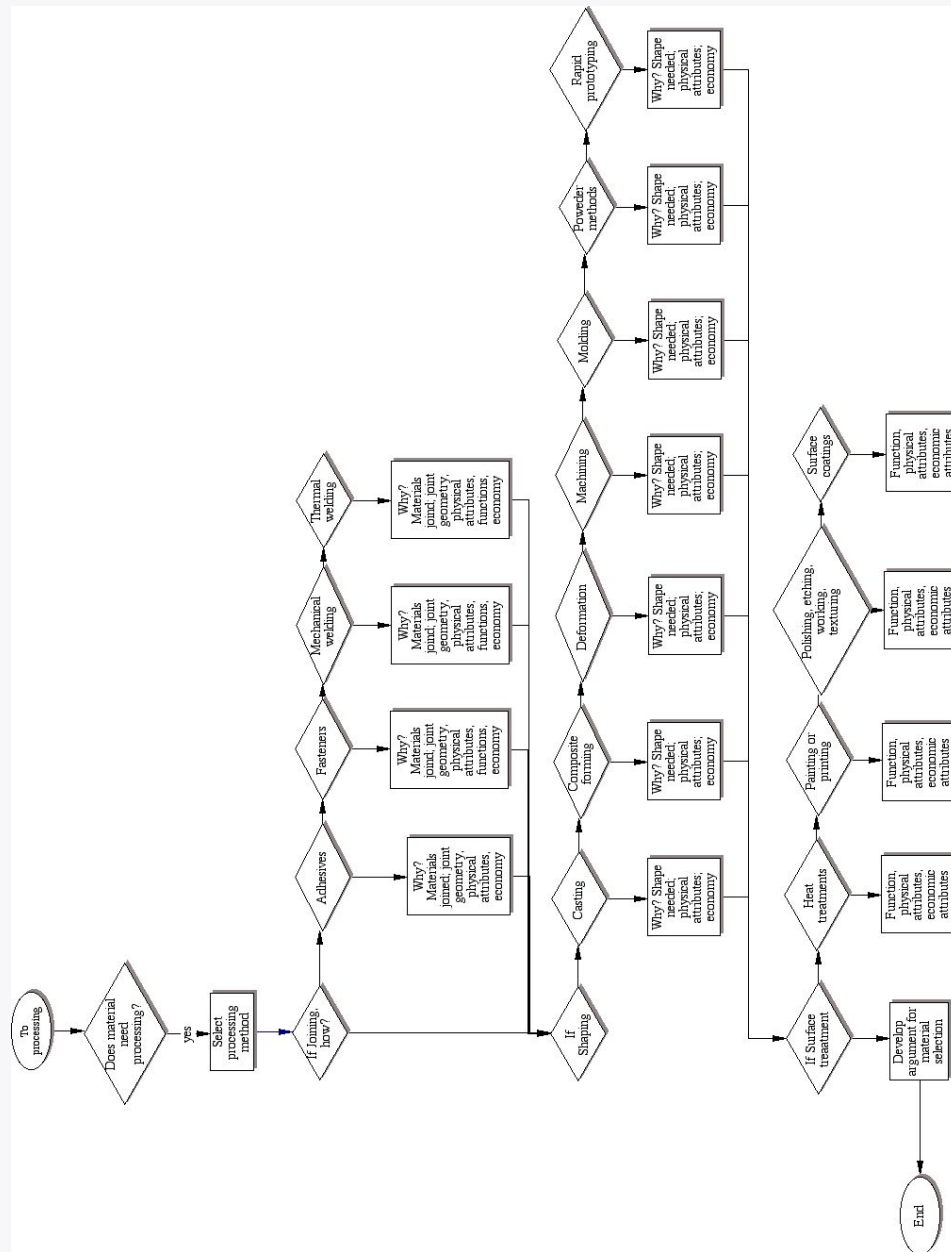

Appendix C: Semi-structured Interview Protocol

Because of the problem-based approach to this course, we know that it may have been challenging for you. We would like to ask you some questions about it so that we may improve the course for next year.

Can you tell us what the most challenging aspect of the course was? That is, what did you find most difficult? Why was it difficult?

What could the instructors have done to make it more effective (not necessarily easier)? How would that have helped?

Did you study outside of class differently for this course? If so, how? How much time did you spend studying outside of class compared to the other courses you take?

How did your group discussions go? When did you typically discuss the problem with your group members? What was typically the focus of those discussions? How much time did you typically spend discussing the problem within your group?

How much did you learn from your fellow group members? How much from other groups? How did you go about learning from what others in the class were doing?

How did you use the reading materials provided to solve the problems and/or study for the exams? How does the amount of the reading compare between this course and your other courses?

Compared with other engineering courses that you have completed, how much do you think that you learned in this course? Did you learn something different in this course?

What was the most challenging aspect of working with others in teams? Why was it challenging?

How did your team determine roles for each of the members?

Appendix D: Problem Module 7

1. The Problem to Solve

You are considering designing an automotive flywheel to take advantage of regenerative braking to store energy. You need to decide what materials to consider using for the flywheel itself. A bit of thought reveals that you want the flywheel to maximize the energy it can store for a given mass, or U/m .

Write a report selecting three or four candidate materials for such a flywheel. Use Ashby charts to select the materials and include them in your report. Your candidate materials should be from different classes of materials if possible (i.e., select the best material from different classes of materials unless the whole class of materials is obviously unsuited). Explain how you selected your candidate materials. Explain the advantages and disadvantages of the different candidates.

In a separate section compare the energy storage per unit mass (energy density) of a flywheel with other energy storage means (gasoline, batteries, etc.) and comment on the usefulness of a flywheel for energy storage in regenerative braking or other transportation usage.

2. Solution Guide

The energy stored in a flywheel is given by

$$U = \frac{1}{2} J \omega^2 \quad (1)$$

where J is the polar moment of inertia, and ω is the angular velocity. The maximum energy that can be stored for a given flywheel is determined by the centrifugal stresses that develop. The maximum principal stress in a spinning disc of uniform thickness is given by

$$\sigma_{\max} = \left(\frac{2}{3 + \nu} \right) \rho R^2 \omega^2 \quad (2)$$

Use Eq. 2 to determine the maximum angular velocity a given flywheel can be used at. Substitute this into Eq. 1 and then determine the energy density for a flat disc flywheel. You may formulate the problem for a spinning ring as well, but the material index will not be substantially different.

Appendix E: Data Dictionary of Final Axial Codes from Student Interviews with Frequency Count

Group dynamics (*applied to 123 idea units*):

- How they did the work
- Who did what (Roles)
- How groups managed the workload
- Process of putting paper together
- Challenges/success of working with a group
- Group skills

Co-Construction (*applied to 55 idea units*):

- Shared understanding of the solution
- Shared understanding of concepts
- Structural characteristics of the problem
- Peer teaching/lack thereof
- Learning across groups

Course Structure (*applied to 94 idea units*)

- Lectures (need for, schedule of, etc.)
- Perception of structure / organization?
- Coverage – Range, breadth (i.e., NOT difficulty – did I learn about the full range of materials and properties that my traditional classmates learned?)
- Scope – Depth of coverage (do I have to know more about particular concepts than I would if I had taken a traditional version of the course?)
- Pace – TIME allotted for particular activities, transition between modules, etc.
- Relationship between problems and tests
- Did the activities in the class help me succeed on the test?
- Do I know what will be on the test?

Student role (*applied to 79 idea units*):

- Self-directed learning
- What did they do to prepare for exams
- Self-efficacy
- I doubt my own understanding of the stuff that's on the test.
- Am I confident about my ability to answer what's on the test?
- Volume of reading, etc.

- Workload/demand on students (i.e., "You're asking too much of me," or "Students in the traditional course didn't have to work as hard as I did.")
- Difficulty of material covered
- How much time they spent preparing for exams
- Perception of what student's responsibility is or should be

Facilitator Role (*applied to 43 idea units*):

- Unclear guidance
- Feedback
- Uncertainty about grades/performance
- Uncertainty about direction
- Perception of what instructor's responsibility is or should be (NOT including expectation of lecture)
- Perception of what instructor IS doing
- Critique of how well the instructor is performing his role

Resources (*applied to 45 idea units*):

- When did you use the textbook, internet, etc?
- What resources were used?
- Module resources – when were they used?
- Critique of materials
- Request for additional resources

Other (*applied to 3 idea units – two were unintelligible and the third was an incomplete thought followed by a change of topic by the interviewee*):

- Anything that didn't seem to fit in one of the above categories