

**Identification of a distinct glucocorticosteroid-insensitive pulmonary macrophage phenotype in COPD**

Kirandeep K. Chana<sup>1</sup>, Peter S. Fenwick<sup>1</sup>, Andrew G. Nicholson<sup>1,2</sup>, Peter J. Barnes<sup>1</sup>, Louise E. Donnelly<sup>1</sup>

<sup>1</sup>Airway Disease, National Heart and Lung Institute, Imperial College London, Dovehouse Street, London, SW3 6LY, UK

<sup>2</sup>Department of Histopathology, Royal Brompton and Harefield NHS Foundation Trust, Sydney Street, London, SW3 6NP, UK

Corresponding author:

Professor Louise E. Donnelly

Airway Disease,

National Heart and Lung Institute,

Imperial College London,

Dovehouse Street,

London, SW3 6LY, U.K

Tel: +44 (0)20 7594 7895

Fax: +44 (0)20 7351 8126

email: [l.donnelly@imperial.ac.uk](mailto:l.donnelly@imperial.ac.uk)

**Financial support:** This study was supported by a studentship from the BBSRC, UK.

**Key messages**

- Human pulmonary macrophages from non-smokers, smokers or COPD patients do not align with the ‘M1’ and ‘M2’ macrophage markers identified by *in vitro* and *in vivo* models.
- A specific macrophage population of density 1.036-1.048g/ml is glucocorticosteroid insensitive in COPD lungs.
- Expression of cell surface markers is reduced in COPD macrophages and a HLA-DR<sup>+</sup>CD14<sup>-</sup>CD16<sup>-</sup> cell type accounts for approximately half of these cells.
- COPD macrophages exhibit a functionally distinct phenotype that may be amenable to targeted therapies.

**Capsule summary:** A distinct, glucocorticosteroid-insensitive macrophage phenotype is found in the lungs of COPD patients that cannot be classified by current macrophage phenotypic markers; Therefore, COPD macrophages may represent a disease specific phenotype.

**Key words:** MMP-9, flow cytometry, CD163, CD206

**Abbreviations:** CD – cluster of differentiation; COPD – chronic obstructive pulmonary disease; FEV<sub>1</sub> – forced expiratory volume in one second; FMO – fluorescence minus one; FVC – forced vital capacity; IFN – interferon; IL – interleukin; LPS – lipopolysaccharide; MFI – median fluorescence intensity; MMP – matrix metalloproteinase; MTT - 3-[4,5-dimethylthiazol-2-yl]-2,5-diphenyl tetrazolium bromide ; PBS – phosphate buffered saline; PE – phycoerythrin; TNF $\alpha$  – tumor necrosis factor  $\alpha$ ; 7-AAD -7-aminoactinomycin D;

**Abstract**

**Background:** In COPD, pulmonary macrophages increase in number, release increased levels of inflammatory mediators and respond poorly to glucocorticosteroids. Whether this is due to a change in macrophage phenotype or localized activation is unknown.

**Objective:** To investigate whether COPD macrophages are a distinct phenotype.

**Methods:** Macrophage populations were isolated from human lung tissue from non-smokers, smokers, and COPD patients using Percoll density gradients. Five macrophage populations were isolated on the basis of density (1.011-1.023; 1.023-1.036; 1.036-1.048; 1.048-1.061. 1.061-1.073 g/ml) and cell surface expression of CD14, CD16, CD163, CD40 and CD206 assessed by flow cytometry. Release of active matrix metalloproteinase (MMP)-9, TNF $\alpha$ , CXCL8 and IL-10 were measured by ELISA.

**Results:** The two least dense fractions were >90% apoptotic/necrotic, with remaining fractions >70% viable. Macrophages from non-smokers and smokers were CD163<sup>+</sup>, CD206<sup>+</sup>, CD14<sup>+</sup>, CD40<sup>-</sup>, whereas COPD macrophages were less defined showing significantly lower expression of all receptors. There were no differences in receptor expression associated with density. COPD macrophages of density 1.036-1.048g/ml released higher levels of active MMP-9 compared with cells from non-smokers, with no difference between remaining fractions. This COPD macrophage population was less responsive to budesonide, compared to those from non-smokers and smokers when stimulated with lipopolysaccharide (LPS). Glucocorticosteroid insensitivity was selective for pro-inflammatory cytokines as budesonide inhibition of LPS-stimulated IL-10 release was similar from all macrophages.

**Conclusions** This study identifies a specific macrophage phenotype in the lungs of COPD patients that are glucocorticosteroid-insensitive with a density of 1.036-1.048g/ml but do not correspond to the current concept of macrophage phenotypes.

## Introduction

Inflammation is a prominent feature of chronic obstructive pulmonary disease (COPD), which is primarily caused by cigarette smoking in industrialized nations but is driven by indoor pollution in the developing world<sup>1</sup>. Macrophages may play a pivotal role in driving this underlying inflammation<sup>2</sup> which subsequently leads to tissue damage, fibrosis of the small airways, chronic bronchitis and emphysema<sup>3, 4</sup>. This inflammation is insensitive to glucocorticosteroid therapy<sup>5</sup> which may, in part, be due to macrophages<sup>6, 7</sup>.

Macrophages can be 'classically-activated' following priming with interferon (IFN) $\gamma$  and stimulation with lipopolysaccharide (LPS), or 'alternatively-activated' by exposure to interleukin (IL)-4 or IL-13<sup>8, 9</sup>. These distinct macrophage 'activation' or 'polarization' states were first described almost four decades ago<sup>10, 11</sup> and may reflect different macrophage phenotypes<sup>12</sup>. These phenotypes have been assigned M1 corresponding broadly to 'classically activated' and M2 corresponding to 'alternatively activated'<sup>13</sup>. However, differences in macrophage responses have been further observed within the M2 phenotype resulting in the sub-classification of M2a, M2b and M2c that are induced by IL-4/IL-13, immune complexes/LPS and IL-10 respectively<sup>13</sup>. However, these phenotypes may not be fixed and may switch depending on the local microenvironment.

It is possible that the highly activated pulmonary macrophages in COPD patients may represent a shift in phenotype. Alveolar macrophages from cigarette smokers show increased expression of 'M2-like' related genes whereas cells from COPD patients showed a suppression of 'classically-activated' 'M1-like' related genes<sup>14</sup>. In contrast, others have shown that active smoking in COPD reduced macrophage phagocytic ability, expression of CD163 and inferred a predominance of pro-inflammatory macrophages<sup>15</sup>. In the lung, the presence of different macrophage populations has been well known and sub-populations of

macrophages have been identified on the basis of density using discontinuous Percoll gradients<sup>16-19</sup>. It has been suggested that these differences in density are related to stages of cell differentiation, maturation or activation states<sup>13, 17</sup> although whether they reflect different phenotypes is unknown. Increasingly, macrophage phenotypes are being investigated in murine models and identified using specific cell surface receptor expression<sup>20-23</sup>. However, in humans, reliable, cell surface markers of the 'classically-activated' macrophage phenotype are not well defined; nevertheless, CD40 is predominantly used<sup>23, 24</sup>, with the scavenger receptor, CD163, and the mannose receptor, CD206 for 'alternatively activated', M2 macrophages<sup>23, 25, 26</sup>. Therefore, this study compared expression of phenotypic markers and the release of inflammatory mediators from human lung tissue macrophages from non-smokers, smokers and patients with COPD isolated using density gradients in order to identify a specific COPD population that might be responsible for the glucocorticosteroid insensitivity of the inflammatory response observed in this disease.

## Methods

### Subject selection

Lung tissue surplus to diagnostic requirements was obtained from pulmonary resections at the Royal Brompton and Harefield NHS Foundation Trust. Smokers had a smoking history of at least 10 pack-years and COPD patients were stable and fulfilled the American Thoracic Society criteria<sup>27</sup>. All subjects gave written informed consent as approved by the London-Chelsea Research Ethics Committee. There were significant differences between, FEV<sub>1</sub>(L), FEV<sub>1</sub> (% predicted), and FEV<sub>1</sub>:FVC ratio, between smokers and COPD subjects compared to non-smokers, but matched for age and smoking history (Table 1).

### Isolation of lung tissue macrophages

Lung tissue macrophages were isolated as described previously using discontinuous Percoll density gradients<sup>28</sup>. Cells were collected from the interface of 10-20% (v/v), 20-30% (v/v), 30-40% (v/v), 40-50% (v/v) and 50-60% (v/v) Percoll layers corresponding to densities of 1.011-1.023; 1.023-1.036; 1.036-1.048; 1.048-1.06; 1.061-1.073 g/ml. Macrophage purity was confirmed using the Reastain Quick-Diff Kit (Genatur, London, UK) according to manufacturers' instructions, and anti-CD68 staining as previously described<sup>29</sup>. Additional detail is provided in an online data supplement.

### Measurement of viability

Lung tissue macrophages isolated from the interface of each Percoll gradient were stained with Annexin V-PE/7-AAD using the Annexin V apoptosis detection kit according to the manufacturer's instructions (Beckton Dickinson, Oxford, UK). To assess the effect of experimental conditions on cell viability the reduction of 3-[4,5-dimethylthiazol-2-yl]-2,5-diphenyl tetrazolium bromide (MTT), to formazan was measured colorimetrically. Untreated

cells were considered 100% viable. None of the treatments used in this study altered cell viability.

### **Measurement of cell surface markers**

After exclusion of dead cells, doublets, contaminating T cells and dendritic cells, HLA-DR<sup>+</sup> cells were gated and separated according to expression of CD14 and CD16, followed, in sequence by expression of CD163, CD40 and CD206. Quadrant gates were set using the appropriate fluorescence minus one (FMO) control. Additional detail on this method and an example of the gating strategy is available in an online data supplement (Fig. E1.) Data are expressed as the percentage of cells that express the protein being investigated and as relative fluorescence intensity, which was calculated by the fluorescence values (median channel) of the cells stained with antibody divided by the fluorescence values (median channel) for the respective control (MFI).

### **Measurement of active MMP-9**

Release of active MMP-9 into cell culture media was measured using a commercially available kit according to the manufacturer's instructions (R&D Systems, Abingdon, UK).

### **Measurement of CXCL8, TNF $\alpha$ and IL-10 using ELISA**

Macrophages were seeded into 96-well plates at a density of  $10^5$  cells per well and allowed to adhere overnight. Cells were pre-treated for 1h with budesonide at the concentrations indicated followed by stimulation with a sub-maximal concentration of LPS (10ng/ml) (*Salmonella enterica* serotype enteritidis) for 20h as described previously<sup>30</sup>. Cell-free supernatants were removed and CXCL8, TNF $\alpha$  and IL-10 were measured by ELISA (R&D Systems, Abingdon, UK). The lower limit of detection for these assays was 31pg/ml.



**Statistics**

Comparisons were conducted using Kruskal-Wallis tests followed by Dunn's post-correctional tests or Wilcoxon signed rank tests as appropriate with  $p < 0.05$  considered significant.  $EC_{50}$  values were analyzed using non-linear regression analysis. All analyses were performed using 'GraphPad' Prism software (GraphPad Software Inc., San Diego, USA).

## Results

Approximately 90% of cells extracted from the 10-20% ( $v/v$ ), and 20-30% ( $v/v$ ) Percoll interfaces were non-viable resulting in their exclusion from further analysis (Table 2). Cell viability increased with increasing cell density, with >70% of cells viable in the remaining cell fractions (Table 2). Cells from the three remaining viable fractions had clearly defined nuclei and cytoplasm reminiscent of macrophages, with no clear morphological differences (Fig. E2) and were confirmed to be derived from a macrophage lineage by positive staining with anti-CD68 (Fig. E3). The distribution of macrophages across the separate fractions was similar regardless of the origin of the tissue (Table E1) and the number of macrophages isolated per gram of tissue was also similar although significantly more macrophages were isolated from the 50-60% ( $v/v$ ) interface of tissue from smokers compared to non-smokers and COPD patients (Table E1.).

### Expression of cell surface markers on lung macrophages

Initially, multi-parameter flow cytometric analysis was performed on macrophage fractions isolated from lung tissue from non-smokers. Within the cells isolated from the interface of 30-40% ( $v/v$ ) Percoll, over 90% of the cells were HLA-DR<sup>+</sup> and of these >95% were positive for CD14 (Fig. 1, green and blue boxes) of which approximately 15% were also CD16<sup>+</sup> (Fig. 1, blue box). Within the CD14<sup>+</sup>CD16<sup>-</sup> population, >70% stained positively for CD163 and of these, >90% were negative for CD40 (Fig. 1, grey boxes). Approximately 6% of the HLA-DR<sup>+</sup> cells were CD14<sup>-</sup>CD16<sup>-</sup> (Fig. 1, orange box), yet subsequent analysis showed that expression of CD163, CD40 and CD206 followed the same pattern as the CD14<sup>+</sup>CD16<sup>-</sup> cells. Within CD14<sup>+</sup>CD16<sup>+</sup> macrophage population (Fig. 1, blue box), >80% of the cells were CD163<sup>+</sup>, however, regardless of CD163 expression approximately 80% were CD40<sup>-</sup>. All cells expressed CD206 regardless of other cell surface receptors present. There were no

differences in the pattern of cell surface receptor expression across the three Percoll fractions (Fig. 1 and Figs. E4 and E5).

A similar pattern of cell surface receptor expression was observed in macrophages from the same fraction isolated from the lung tissue of smokers (Fig. 2). In this case, HLA-DR<sup>+</sup> cells were >65% positive for CD14 (Fig. 2, green and blue boxes) of which approximately 10% were also CD16<sup>+</sup> (Fig. 2, blue box). Within the CD14<sup>+</sup>CD16<sup>-</sup> population approximately 60% stained positively for CD163 and of these, >70% were negative for CD40 (Fig. 2, grey boxes). Approximately 30% of the HLA-DR<sup>+</sup> cells were CD14<sup>-</sup>CD16<sup>-</sup> (Fig. 2, orange box), with approximately half CD163<sup>+</sup>CD40<sup>-</sup>CD206<sup>+</sup>. The CD14<sup>+</sup>CD16<sup>+</sup> macrophage population (Fig. 2, blue box) were >70% CD163<sup>+</sup>, however, regardless of CD163 expression approximately 60% were CD40<sup>-</sup>. All cells expressed (data not shown). Again, no difference in expression of any of the markers examined could be determined across the different macrophage fractions (Figs. E6 and E7).

Finally, a similar analysis was performed on macrophages isolated from 30-40% (v/v) Percoll interface from the tissue of patients with COPD. In this instance, only approximately 50% were positive for CD14 (Fig. 3, green and blue boxes) of which approximately 25% were also CD16<sup>+</sup> (Fig. 3, blue box). Of the CD14<sup>+</sup>CD16<sup>-</sup> population, approximately 15% were CD163<sup>+</sup> and of these, all were negative for CD40 (Fig. 3, grey box). Approximately half the macrophages were CD14<sup>-</sup>CD16<sup>-</sup> (Fig. 3 orange box) and of these most were CD163<sup>-</sup>CD40<sup>-</sup> yet stained positive for CD206. The CD14<sup>+</sup>CD16<sup>+</sup> macrophage population (Fig. 3, blue box) showed an equal distribution of cells positive and negative for CD163. However, regardless of CD163 expression all were CD40<sup>-</sup> (data not shown). All cells expressed CD206 (data not shown) and again there were no differences across the different fractions (Figs. E8 and E9).

This multi-parameter approach suggested that macrophages isolated from the lungs of patients with COPD exhibited a different pattern of marker expression compared with macrophages isolated from the lungs of non-smokers and smokers. To perform further comparisons, the percentage of HLA-DR<sup>+</sup> cells and the level of each specific marker as assessed by MFI were also analyzed.

There were no significant differences in the expression of HLA-DR expression with increasing cell density or between subject groups (data not shown). Fewer lung tissue macrophages isolated from COPD subjects were positive for CD14, CD16, CD40, and CD163 compared to any other subject group with no difference observed between cell densities (Fig. 4 A-D). However, all cells expressed CD206 (Fig. 4E). Macrophages from COPD subjects also expressed lower levels of the receptors as measured by MFI when compared to cells from non-smokers and smokers with no differences observed between cell densities (Fig. 4 F-J).

Having shown that COPD macrophages have altered expression of cell surface markers and that fractionations on the basis of density did not alter these markers, it was important to determine whether this was associated with macrophage function.

### **Measurement of inflammatory mediator release from lung tissue macrophages**

Alveolar macrophages from COPD patients are activated releasing proteases and cytokines that are resistant to glucocorticosteroid inhibition<sup>6, 31, 32</sup>, therefore the functional responses of each of the macrophage fractions from the different subject groups were examined. Macrophages extracted from lung tissue from smokers and COPD subjects released greater amounts of active MMP-9 compared to non-smokers (non-smokers:  $2.8 \pm 1.1$  ng/ml vs. smokers:  $19.6 \pm 5.2$  ng/ml and vs. COPD:  $15.2 \pm 6.5$  ng/ml MMP-9,  $p < 0.05$ ) (Fig. 5A). A similar trend was observed in the denser macrophage fractions but this was not significant (Fig. 5B-

C). These data suggested density of macrophages was associated with functional differences of the cells; therefore the effect of stimulating these cells with LPS and measurement of inflammatory cytokines was performed.

Baseline release of TNF $\alpha$ , CXCL8 and IL-10 were similar for all cell fractions and between macrophages from different subject groups (Table 3). LPS stimulated all macrophage fractions to release similar levels of cytokines with no difference between fractions or subject groups.

### **Effect of a glucocorticosteroid on LPS-stimulated cytokine release**

Next, the effect of a glucocorticosteroid, budesonide, on the release of LPS-stimulated cytokines was evaluated. Budesonide inhibited LPS-stimulated TNF- $\alpha$  release from the 30-40% ( $v/v$ ) cell fraction extracted from the lungs of non-smokers and smokers by approximately 60-80% with values of  $EC_{50}=0.5\pm 0.1nM$ ,  $n=6$  and  $2.0\pm 1.2nM$ ,  $n=11$  respectively. In contrast, macrophages from the 30-40% ( $v/v$ ) cell fraction from COPD subjects were unresponsive to budesonide (Fig. 6A). This effect of glucocorticosteroid insensitivity was less marked in cells from COPD patients isolated at the 40-50% ( $v/v$ ) interface (Fig. 6B) with no difference in responsiveness to glucocorticosteroids in the densest fraction (Fig. 6C).

A similar pattern of glucocorticosteroid responsiveness was observed when the release of CXCL8 was measured. Again, macrophages from non-smokers and smokers isolated at the 30-40% ( $v/v$ ) interface were susceptible to inhibition by budesonide ( $EC_{50}=0.6\pm 0.1nM$ ,  $n=6$  and  $1.0\pm 0.3nM$ ,  $n=11$  respectively) (Fig. 6D). This relative glucocorticosteroid insensitivity was lost within the denser macrophage fractions (Fig. 6E-F).

Finally, the effect of budesonide on LPS-stimulated IL-10 release was examined. Budesonide inhibited IL-10 release in a concentration-dependent manner from all cell fractions and in all subject groups (Fig. 6G-I). The EC<sub>50</sub> values were approximately 1nM for all cell fractions and subject groups. Maximum LPS-stimulated IL-10 inhibition by budesonide for non-smokers was approximately 80%, and 50-60% for smokers and COPD subjects across all fractions (Fig. 6G-I).

## Discussion

Macrophages play a pivotal role in the pathophysiology of COPD where alveolar macrophages increase in number, release more inflammatory mediators such as CXCL8, TNF $\alpha$  and MMP-9, and respond less well to glucocorticosteroids<sup>6, 32</sup>. This study investigated the possibility that these macrophages might represent a distinct phenotype associated with COPD and showed that within the pulmonary macrophage population, approximately a third of these cells are glucocorticosteroid insensitive, release high levels of activated MMP-9 but cannot be distinguished from other macrophages by the cell surface markers examined. However, all macrophages from the COPD lung had significantly reduced expression of many of cell surface receptors.

The present study showed that the least dense macrophage fractions (1.011-1.023g/ml; 1.023-1.036g/ml) represented a high proportion of apoptotic/dead fraction cells and were excluded from further analysis. The cell population at the 1.036-1.048g/ml interface (30-40% (v/v) cell fraction) were similar to that identified in rodents where cells with a density of 1.036g/ml cell fraction, appear enlarged and begin to show signs of degeneration<sup>33</sup> whereas the smaller, denser cells, 1.05g/ml-1.068g/ml, appeared intact and showed no signs of degeneration<sup>34</sup>. In humans with active tuberculosis, alveolar macrophages have a density of less than 1.03g/ml up to 1.04g/ml<sup>35</sup>, which broadly corresponds to the 30-40% (v/v) fraction presented here. However, whether macrophage density is a marker of age or of alveolar macrophages in general, remains unclear.

It is known that pulmonary macrophages may persist for many years within the lung, since donor macrophages can be detected 2-3 years following transplant<sup>36</sup>; however, specific identification of these long-lived, resident cells in an individual that has not undergone transplant is difficult. Rodent studies of pulmonary macrophage depletion suggest that

macrophages repopulate the lung rapidly<sup>37, 38</sup> and this turnover is increased following infection<sup>39</sup>. These data suggest that during disease processes macrophage numbers and populations may alter and therefore similar responses may also be occurring in inflammatory lung diseases such as COPD.

In order to determine whether macrophages from the lungs of COPD patients differed from those isolated from control samples, cell surface phenotypic markers were examined with specific reference to macrophages of differing density. Multi-parameter, flow cytometric methodology is a well-established technique to measure cellular characteristics but there are many challenges in designing these analyses, including highly variable expression levels of markers, variable brightness of fluorochromes, emission overlap and stability of some fluorochromes. Furthermore, one of the major hindrances of investigating macrophages using this technique is their intractable autofluorescence. Intracellular autofluorescence of alveolar macrophages is thought to be a marker of endocytosed fluorescent particles from, for example, cigarette smoke<sup>40</sup>. Furthermore, alveolar macrophage autofluorescence in smokers who cease smoking show reduced autofluorescence<sup>40</sup>. Although, not investigated specifically in this study, the autofluorescence of macrophages was similar between subject groups investigated, therefore any differences in fluorescence intensity measured is unlikely to be due to inherent differences in autofluorescence.

Analysis of macrophage cell surface receptor expression, showed >70% of macrophages from non-smokers and >50% from smokers were CD14<sup>+</sup>CD16<sup>-</sup>CD163<sup>+</sup> and CD40<sup>-</sup>, and therefore appear to display a macrophage phenotype encompassing properties of 'alternative-activation'. However, no differences were observed between cells isolated from the different Percoll interfaces, indicating that cell density could not be discriminated by these markers. Conversely, macrophages isolated from COPD patients showed a more variable receptor profile. Those that were CD14<sup>+</sup>CD16<sup>-</sup> were >80% CD163 negative, and of



these, all were CD40 negative. This differs when compared to the cells isolated from the lungs of non-smokers and smokers. Of the CD14<sup>+</sup>CD16<sup>+</sup> macrophages isolated from COPD subjects there was an equal distribution of CD163<sup>-</sup> and CD163<sup>+</sup> cells and therefore could not be characterized as 'classically' or 'alternatively' activated. These patterns were not consistent with a linear change, but more of a mix of individual alterations which were not consistent with a global shift in phenotype.

Examining receptor expression in combination showed a HLA-DR<sup>+</sup> CD14<sup>-</sup>CD16<sup>-</sup> macrophage population was present in all subject groups and cell fractions, this population was most prominent in macrophages isolated from COPD subjects and was distinct from the other macrophage populations. To the best of our knowledge, this population has been identified for the first time in this study and has not previously been reported in the literature. To verify that this population was not an artifact, further analysis was conducted to confirm the data was not being skewed due to high spectral overlap between the fluorochromes for CD14 and CD16. The fluorochromes associated with CD14 and CD16 were APC-CY7 and Pacific Blue respectively, and as such, there is no spectral overlap. However, the receptors investigated in this study do not show differences between cell fractions. This may be because differences do not exist between the receptor expression levels between cell fractions, or the differences between expression levels are too subtle to be detected by flow cytometry.

Alveolar macrophages from non-smokers express low levels of CD14 which increases during inflammation<sup>41</sup>. Therefore, it would have been expected that macrophages isolated from COPD lung, would express higher levels of CD14 compared to controls. However, this was not observed but may be due to COPD lung also containing higher levels of neutrophil elastase and other proteases, such as MMP-9<sup>42, 43</sup>, that in turn, may have removed the receptors from the cell surface. This may also explain why all the receptors investigated were

at lower levels on macrophages isolated from COPD lung compared to controls and may contribute to reduced phagocytosis reported for COPD macrophages<sup>44, 45</sup>.

Alveolar macrophages from COPD patients release more active MMP-9 than non-smokers and smokers<sup>32</sup>. The present study showed that macrophages isolated from the 30-40% ( $v/v$ ) Percoll interface from smokers and COPD released increased levels of active MMP-9 compared to non-smokers suggesting this fraction may correspond to the alveolar macrophage population<sup>32</sup>. This difference became less marked with the denser macrophage populations.

A number of studies have indicated that neither high-dose inhaled nor oral corticosteroids reduce the levels of CXCL8, or proteases in induced sputum of subjects with COPD<sup>5, 46, 47</sup>. This reduced glucocorticosteroid efficacy in COPD could be due to macrophage insensitivity<sup>6</sup> and is supported by this study where macrophages isolated from COPD subjects were functionally distinct. The least dense macrophages isolated from the 30-40% ( $v/v$ ) Percoll interface were significantly less responsive to budesonide when isolated from COPD patients compared to cells from tissue of non-smokers and smokers. This effect was lost with increasing cell density and all macrophages isolated at the 50-60% ( $v/v$ ) interface were sensitive to glucocorticosteroids. These cells may represent a less mature, newly recruited macrophage population. However, glucocorticoid insensitivity in the more mature, less dense cells was selective for LPS-stimulated CXCL8 and TNF $\alpha$  release, since budesonide inhibition of LPS-stimulated IL-10 release from these fractions was similar for macrophages from both smokers and COPD subjects. Although budesonide inhibited pro-inflammatory responses from the mature macrophage population isolated from COPD subjects, these cells were not completely glucocorticosteroid insensitive since IL-10 was inhibited by this treatment. This suggests that glucocorticosteroids may contribute to worsening lung inflammation observed in COPD since they fail to suppress pro-inflammatory cytokines but inhibit anti-

inflammatory cytokines. The differential steroid responsiveness of each of these fractions might also account for the variability in data reported by other groups<sup>48</sup>. Therefore, macrophages from COPD lung tissue may represent a phenotype encompassing properties of both ‘classically activated’ M1-like and ‘tumor associated’ ‘M2b-like’ macrophages<sup>49</sup>. Exactly why the more mature macrophages show a differential response to glucocorticosteroids may be due to their residency in a highly oxidative environment. Oxidative stress drives glucocorticosteroid insensitivity<sup>7, 31, 50</sup> and therefore, the longer macrophages are exposed to this environment, the more likely they are to develop a reduced response to steroids.

All the lung resection tissue used in this study was macroscopically not tumorous; however it was predominantly from subjects with primary lung cancer. Therefore, it is unclear whether tumor associated cytokines played a role in the macrophage phenotype observed. In addition, the lungs of COPD subjects are colonized with bacteria such as *Haemophilus influenzae* which may polarize macrophages towards a ‘classically-activated’ phenotype<sup>51</sup>. This may explain why the macrophages isolated from COPD subjects from the 30-40% (<sup>v/v</sup>) Percoll interface present properties of both ‘classically activated’ and ‘regulatory’ macrophages.

This study has identified a specific pulmonary macrophage phenotype in COPD that is glucocorticosteroid insensitive. Targeting this population directly, might allow future therapies that remove this phenotype specifically so that the host-defense role of macrophages is preserved by the remaining populations.

## **Acknowledgements**

This project was supported by the National Institute of Health Research Respiratory Disease Biomedical Research Unit at the Royal Brompton Hospital and Harefield Foundation NHS Trust and Imperial College London.

## References

1. Salvi SS, Barnes PJ. Chronic obstructive pulmonary disease in non-smokers. *Lancet* 2009; 374:733-43.
2. Barnes PJ. Macrophages as Orchestrators of COPD. *J. COPD* 2004; 1:50-70.
3. Saetta M, Turato G, Facchini FM, Corbino L, Lucchini RE, Casoni G, et al. Inflammatory cells in the bronchial glands of smokers with chronic bronchitis. *Am. J. Respir. Crit. Care Med.* 1997; 156:1633-9.
4. Hogg JC, Chu F, Utokaparch S, Woods R, Elliott WM, Buzatu L, et al. The nature of small-airway obstruction in chronic obstructive pulmonary disease. *N. Engl. J. Med.* 2004; 350:2645-53.
5. Culpitt SV, Maziak W, Loukidis S, Nightingale JA, Matthews JL, Barnes PJ. Effect of high dose inhaled steroid on cells, cytokines, and proteases in induced sputum in chronic obstructive pulmonary disease. *Am. J. Respir. Crit. Care Med.* 1999; 160:1635-9.
6. Culpitt SV, Rogers DF, Shah P, De Matos C, Russell RE, Donnelly LE, et al. Impaired inhibition by dexamethasone of cytokine release by alveolar macrophages from patients with chronic obstructive pulmonary disease. *Am. J. Respir. Crit. Care Med.* 2003; 167:24-31.
7. Ito K, Lim S, Caramori G, Chung KF, Barnes PJ, Adcock IM. Cigarette smoking reduces histone deacetylase 2 expression, enhances cytokine expression, and inhibits glucocorticoid actions in alveolar macrophages. *FASEB J.* 2001; 15:1110-2.
8. Gordon S. Alternative activation of macrophages. *Nat Rev Immunol* 2003; 3:23-35.
9. Gordon S, Taylor PR. Monocyte and macrophage heterogeneity. *Nat Rev Immunol* 2005; 5:953-64.

10. Walker WS. Functional heterogeneity of macrophages: subclasses of peritoneal macrophages with different antigen-binding activities and immune complex receptors. *Immunology* 1974; 26:1025-37.
11. Mokoena T, Gordon S. Human macrophage activation. Modulation of mannosyl, fucosyl receptor activity in vitro by lymphokines, gamma and alpha interferons, and dexamethasone. *J. Clin. Invest.* 1985; 75:624-31.
12. Mantovani A, Sozzani S, Locati M, Allavena P, Sica A. Macrophage polarization: tumor-associated macrophages as a paradigm for polarized M2 mononuclear phagocytes. *Trends in Immunology* 2002; 23:549-55.
13. Mantovani A, Sica A, Locati M. Macrophage polarization comes of age. *Immunity* 2005; 23:344-6.
14. Shaykhiev R, Krause A, Salit J, Strulovici-Barel Y, Harvey BG, O'Connor TP, et al. Smoking-dependent reprogramming of alveolar macrophage polarization: implication for pathogenesis of chronic obstructive pulmonary disease. *J. Immunol.* 2009; 183:2867-83.
15. Kunz LI, Lapperre TS, Snoeck-Stroband JB, Budulac SE, Timens W, van Wijngaarden S, et al. Smoking status and anti-inflammatory macrophages in bronchoalveolar lavage and induced sputum in COPD. *Respir Res* 2011; 12:34.
16. Holian A, Dauber JH, Diamond MS, Daniele RP. Separation of bronchoalveolar cells from the guinea pig on continuous gradients of Percoll: functional properties of fractionated lung macrophages. *J. Reticuloendothel. Soc.* 1983; 33:157-64.
17. Nakstad B, Lyberg T, Skjorten F, Boye NP. Subpopulations of human lung alveolar macrophages: ultrastructural features. *Ultrastruct. Pathol.* 1989; 13:1-13.
18. Dauber JH, Holian A, Rosemiller ME, Daniele RP. Separation of bronchoalveolar cells from the guinea pig on continuous density gradients of Percoll: morphology and

- cytochemical properties of fractionated lung macrophages. *J. Reticuloendothel. Soc.* 1983; 33:119-26.
19. Murphy MA, Herscowitz HB. Heterogeneity among alveolar macrophages in humoral and cell-mediated immune responses: separation of functional subpopulations by density gradient centrifugation on Percoll. *J. Leukoc. Biol.* 1984; 35:39-54.
  20. Taylor ML, Noble PW, White B, Wise R, Liu MC, Bochner BS. Extensive surface phenotyping of alveolar macrophages in interstitial lung disease. *Clin. Immunol.* 2000; 94:33-41.
  21. Buhling F, Ittenson A, Kaiser D, Tholert G, Hoffmann B, Reinhold D, et al. MRP8/MRP14, CD11b and HLA-DR expression of alveolar macrophages in pneumonia. *Immunol. Lett.* 2000; 71:185-90.
  22. St-Laurent J, Turmel V, Boulet LP, Bissonnette E. Alveolar macrophage subpopulations in bronchoalveolar lavage and induced sputum of asthmatic and control subjects. *J. Asthma* 2009; 46:1-8.
  23. Mantovani A, Sica A, Sozzani S, Allavena P, Vecchi A, Locati M. The chemokine system in diverse forms of macrophage activation and polarization. *Trends in Immunology* 2004; 25:677-86.
  24. Verreck FA, de Boer T, Langenberg DM, van der Zanden L, Ottenhoff TH. Phenotypic and functional profiling of human proinflammatory type-1 and anti-inflammatory type-2 macrophages in response to microbial antigens and IFN-gamma and CD40L-mediated costimulation. *J. Leukoc. Biol.* 2006; 79:285-93.
  25. Martinez FO, Gordon S, Locati M, Mantovani A. Transcriptional profiling of the human monocyte-to-macrophage differentiation and polarization: new molecules and patterns of gene expression. *J. Immunol.* 2006; 177:7303-11.

26. Van Ginderachter JA, Movahedi K, Hassanzadeh Ghassabeh G, Meerschaut S, Beschin A, Raes G, et al. Classical and alternative activation of mononuclear phagocytes: picking the best of both worlds for tumor promotion. *Immunobiology* 2006; 211:487-501.
27. ATS. Standards for the diagnosis and care of patients with chronic obstructive pulmonary disease. American Thoracic Society. *Am. J. Respir. Crit. Care Med.* 1995; 152:S77-121.
28. Finney-Hayward TK, Popa O, Bahra P, Li S, Poll CT, Gosling M, et al. Expression of TRPC6 Channels in Human Lung Macrophages. *Am. J. Respir. Cell Mol. Biol.* 2010; 43:296-304.
29. Smith SJ, Fenwick PS, Nicholson AG, Kirschenbaum F, Finney-Hayward TK, Higgins LS, et al. Inhibitory effect of p38 mitogen-activated protein kinase inhibitors on cytokine release from human macrophages. *Br. J. Pharmacol.* 2006; 149:393-404.
30. Tudhope SJ, Finney-Hayward TK, Nicholson AG, Mayer RJ, Barnette MS, Barnes PJ, et al. Different mitogen-activated protein kinase-dependent cytokine responses in cells of the monocyte lineage. *J. Pharmacol. Exp. Ther.* 2008; 324:306-12.
31. Cosio BG, Tsaprouni L, Ito K, Jazrawi E, Adcock IM, Barnes PJ. Theophylline restores histone deacetylase activity and steroid responses in COPD macrophages. *J. Exp. Med.* 2004; 200:689-95.
32. Russell RE, Culpitt SV, DeMatos C, Donnelly L, Smith M, Wiggins J, et al. Release and activity of matrix metalloproteinase-9 and tissue inhibitor of metalloproteinase-1 by alveolar macrophages from patients with chronic obstructive pulmonary disease. *Am. J. Respir. Cell Mol. Biol.* 2002; 26:602-9.



33. Oghiso Y. Morphologic and functional heterogeneity among rat alveolar macrophage fractions isolated by centrifugation on density gradients. *J. Leukoc. Biol.* 1987; 42:188-96.
34. Thompson B, Myrvik QN. Characterization and maturation of alveolar macrophages procured from BCG-induced pulmonary granulomas. *Exp. Lung Res.* 1985; 9:237-53.
35. Kuo HP, Yu CT. Alveolar macrophage subpopulations in patients with active pulmonary tuberculosis. *Chest* 1993; 104:1773-8.
36. Marques LJ, Teschler H, Guzman J, Costabel U. Smoker's Lung Transplanted to a Nonsmoker. *Am. J. Respir. Crit. Care Med.* 1997; 156:1700-2.
37. Matute-Bello G, Lee JS, Frevert CW, Liles WC, Sutlief S, Ballman K, et al. Optimal timing to repopulation of resident alveolar macrophages with donor cells following total body irradiation and bone marrow transplantation in mice. *J. Immunol. Methods* 2004; 292:25-34.
38. Hahn I, Klaus A, Maus R, Christman JW, Welte T, Maus UA. Dendritic Cell Depletion and Repopulation in the Lung after Irradiation and Bone Marrow Transplantation in Mice. *Am. J. Respir. Cell Mol. Biol.* 2011; 45:534-41.
39. Taut K, Winter C, Briles DE, Paton JC, Christman JW, Maus R, et al. Macrophage Turnover Kinetics in the Lungs of Mice Infected with *Streptococcus pneumoniae*. *Am. J. Respir. Cell Mol. Biol.* 2008; 38:105-13.
40. Skold CM, Hed J, Eklund A. Smoking cessation rapidly reduces cell recovery in bronchoalveolar lavage fluid, while alveolar macrophage fluorescence remains high. *Chest* 1992; 101:989-95.
41. Rogler G, Hausmann M, Vogl D, Aschenbrenner E, Andus T, Falk W, et al. Isolation and phenotypic characterization of colonic macrophages. *Clin. Exp. Immunol.* 1998; 112:205-15.

42. Shapiro SD. Proteinases in chronic obstructive pulmonary disease. *Biochem. Soc. Trans.* 2002; 30:98-102.
43. Culpitt SV, Rogers DF, Traves SL, Barnes PJ, Donnelly LE. Sputum matrix metalloproteases: comparison between chronic obstructive pulmonary disease and asthma. *Respir. Med.* 2005; 99:703-10.
44. Taylor AE, Finney-Hayward TK, Quint JK, Thomas CM, Tudhope SJ, Wedzicha JA, et al. Defective macrophage phagocytosis of bacteria in COPD. *Eur. Respir. J.* 2010; 35:1039-47.
45. Berenson CS, Garlipp MA, Grove LJ, Maloney J, Sethi S. Impaired phagocytosis of nontypeable *Haemophilus influenzae* by human alveolar macrophages in chronic obstructive pulmonary disease. *J. Infect. Dis.* 2006; 194:1375-84.
46. Keatings VM, Collins PD, Scott DM, Barnes PJ. Differences in interleukin-8 and tumor necrosis factor-alpha in induced sputum from patients with chronic obstructive pulmonary disease or asthma. *Am. J. Respir. Crit. Care Med.* 1996; 153:530-4.
47. Keatings VM, Jatakanon A, Worsdell YM, Barnes PJ. Effects of inhaled and oral glucocorticoids on inflammatory indices in asthma and COPD. *Am. J. Respir. Crit. Care Med.* 1997; 155:542-8.
48. Ratcliffe MJ, Dougall IG. Comparison of the anti-inflammatory effects of Cilomilast, Budesonide and a p38 Mitogen activated protein kinase inhibitor in COPD lung tissue macrophages. *BMC Pharmacology and Toxicology* 2012; 13:15.
49. Martinez FO, Sica A, Mantovani A, Locati M. Macrophage activation and polarization. *Front. Biosci.* 2008; 13:453-61.
50. Ito K, Yamamura S, Essilfie-Quaye S, Cosio B, Ito M, Barnes PJ, et al. Histone deacetylase 2-mediated deacetylation of the glucocorticoid receptor enables NF-kappaB suppression. *J. Exp. Med.* 2006; 203:7-13.

51. Sica A, Schioppa T, Mantovani A, Allavena P. Tumour-associated macrophages are a distinct M2 polarised population promoting tumour progression: potential targets of anti-cancer therapy. *Eur. J. Cancer* 2006; 42:717-27.

	<b>Non-smokers</b> <b>n=11</b>	<b>Smokers</b> <b>n=45</b>	<b>COPD</b> <b>n=20</b>
<b>Age (years)</b>	60 ± 4	70 ± 2	67 ± 2
<b>Gender M:F</b>	8:3	30: 15	11:9
<b>FEV<sub>1</sub>(L)</b>	2.9 ± 0.3	2.5 ± 0.1	1.7± 0.1* <sup>##</sup>
<b>FVC (L)</b>	3.7 ± 0.3	3.5 ± 0.1	3.1 ± 0.2
<b>FEV<sub>1</sub> (% predicted)</b>	88 ± 6	93 ± 3	68 ± 2*
<b>FVC (% predicted)</b>	100 ± 8	100 ± 5	96 ± 4
<b>FEV<sub>1</sub>:FVC</b>	0.7 ± 0.02	0.7 ± 0.01	0.5 ± 0.02* <sup>##</sup>
<b>Smoking History (Pack Years)</b>	-	39 ± 3	39 ± 7

**Table 1: Subject demographics**

Data are presented as mean ± S.E.M. \*p<0.05 vs smokers<sup>##</sup>p<0.01 vs non-smokers

<b>Percoll Gradient (v/v) (%)</b>	<b>Cell Viability (%)</b>			
	<b>Necrotic</b>	<b>Dead</b>	<b>Live</b>	<b>Apoptotic</b>
<b>10-20%</b>	3 ± 3	92 ± 3	3 ± 1	3 ± 0
<b>20-30%</b>	3 ± 2	78 ± 2	11 ± 2	3 ± 3
<b>30-40%</b>	2 ± 1	21 ± 8*	68 ± 10*	10 ± 1
<b>40-50%</b>	1 ± 1	13 ± 2*	71 ± 3*	14 ± 5
<b>50-60%</b>	1 ± 0	6 ± 2** <sup>#</sup>	86 ± 3** <sup>#</sup>	9 ± 0

**Table 2:** Proportion of apoptotic and necrotic cells in each cell fraction.

Macrophages were isolated from the different interfaces of the Percoll gradient and apoptotic and necrotic markers assessed by FACS. Data are presented as mean ± SEM, n=5. \*p<0.05 \*\*p<0.01 vs 10-20%(<sup>w/v</sup>), <sup>#</sup> p<0.05 vs 20-30%(<sup>w/v</sup>)

Percoll Gradient (v/v) (%)	Baseline (ng/ml)			LPS (10ng/ml) stimulation (ng/ml)		
	CXCL8	TNF $\alpha$	IL-10	CXCL8	TNF $\alpha$	IL-10
<b>30-40</b>	34.3 $\pm$ 6.8	1.2 $\pm$ 0.2	0.2 $\pm$ 0.0	160.7 $\pm$ 26.1*	6.2 $\pm$ 1.5 <sup>##</sup>	1.0 $\pm$ 0.3 <sup>†</sup>
<b>40-50</b>	35.5 $\pm$ 9.4	1.4 $\pm$ 0.2	0.1 $\pm$ 0.0	168.6 $\pm$ 14.5**	5.6 $\pm$ 1.5 <sup>#</sup>	1.0 $\pm$ 0.2 <sup>††</sup>
<b>50-60</b>	23.1 $\pm$ 5.5	1.4 $\pm$ 0.2	0.1 $\pm$ 0.0	131.5 $\pm$ 35.9*	5.7 $\pm$ 1.8 <sup>#</sup>	0.7 $\pm$ 0.1 <sup>†</sup>

**Table 3:** Cytokine release from fractionated human lung macrophages.

\*p<0.05 \*\*p<0.01 vs CXCL8 baseline, #p<0.05 ##p<0.01 vs TNF $\alpha$  baseline †p<0.05 ††p<0.01

vs IL-10 baseline. Data are mean  $\pm$  S.E.M, n=8

## Figure Legends

**Figure 1. Cell surface receptor expression of macrophages isolated from the 30-40% (v/v) Percoll interface from the lung tissue of non-smokers.**

Macrophages were isolated at the 30-40% (v/v) Percoll interface from the lung tissue of non-smokers and cells were incubated with APC-HLA-DR, FITC-CD40, PerCP CY5.5-CD163, PE-CD206, APC-CY7-CD14, Pacific Blue CD16 for 45 min at 4°C and analyzed by flow cytometry. The percentage of cells isolated from the Percoll interfaces of 30-40% (v/v) are presented as mean±SEM, n=3. Figure is a representative of n=3 experiments.

**Figure 2. Cell surface receptor expression of macrophages isolated from the 30-40% (v/v) Percoll interface from the lung tissue of smokers.**

Macrophages were isolated at the 30-40% (v/v) Percoll interface from the lung tissue of non-smokers and cells were incubated with APC-HLA-DR, FITC-CD40, PerCP CY5.5-CD163, PE-CD206, APC-CY7-CD14, Pacific Blue CD16 for 45 min at 4°C and analyzed by flow cytometry. The percentage of cells isolated from the Percoll interfaces of 30-40% (v/v) are presented as mean±SEM, n=3. Figure is a representative of n=3 experiments.

**Figure 3. Cell surface receptor expression of macrophages isolated from the 30-40% (v/v) Percoll interface from the lung tissue of COPD patients.**

Macrophages were isolated at the 30-40% (v/v) Percoll interface from the lung tissue of non-smokers and cells were incubated with APC-HLA-DR, FITC-CD40, PerCP CY5.5-CD163, PE-CD206, APC-CY7-CD14, Pacific Blue CD16 for 45 min at 4°C and analyzed by flow

cytometry. The percentage of cells isolated from the Percoll interfaces of 30-40% (v/v) are presented as mean $\pm$ SEM, n=3. Figure is a representative of n=3 experiments.

**Figure 4. Expression of cell surface markers on macrophages isolated from different Percoll interfaces.**

Macrophages were isolated from resected human lung tissue from non-smokers (NS: n=3), smokers (S: n=3) and COPD (n=3) at the interfaces of 30-40% (v/v) (open bars), 40-50% (v/v) (grey bars) and 50-60% (v/v) (black bars) Percoll. Cells were blocked with IgG for 15 min at room temperature, incubated with the relevant antibody for 45min at 4°C. Cells were washed and resuspended in FACS fix. Data are presented as mean  $\pm$  S.E.M, where \* represents p<0.05, \*\*p<0.01 and \*\*\*p<0.001 for differences from non-smokers and # represents p<0.05, ## p<0.01 and ### p<0.001 for differences from smokers.

**Figure 5. Release of active MMP-9 from lung tissue macrophages.**

Macrophages were isolated from the 30-40% (v/v) (panel A), 40-50% (v/v) (panel B) and 50-60% (v/v) (panel C) interfaces of the Percoll gradient and seeded into cell culture plates. MMP-9 release from all cell fractions was measured using a fluorimetric activity assay. Non-smokers (NS), n=5 (open bars), Smokers (S), n=5 (grey bars), COPD, n=3-5 (black bars). Data are presented as mean $\pm$ SEM and \* represents p<0.05.

**Figure 6. Effect of budesonide on LPS-stimulated cytokine release from lung tissue macrophages.**



Macrophages were isolated from the 30-40% ( $v/v$ ) (panels A, D and G), 40-50% ( $v/v$ ) (panels B, E and H) and 50-60% ( $v/v$ ) (panels C, F and I) interfaces of the Percoll gradient. Cells were pre-treated with budesonide at the concentrations indicated for 1h, followed by LPS stimulation (10ng/ml) for 20h and media harvested. TNF $\alpha$  panels (A-C), CXCL8 (panels D-F) and IL-10 (panels G-I) were measured by ELISA, data was then normalized to LPS stimulation (100%). Non-smokers, n=6 ( $\blacktriangle$ ), Smokers, n=11 ( $\bullet$ ), COPD, n=7 ( $\circ$ ). Data are presented as mean  $\pm$  SEM.

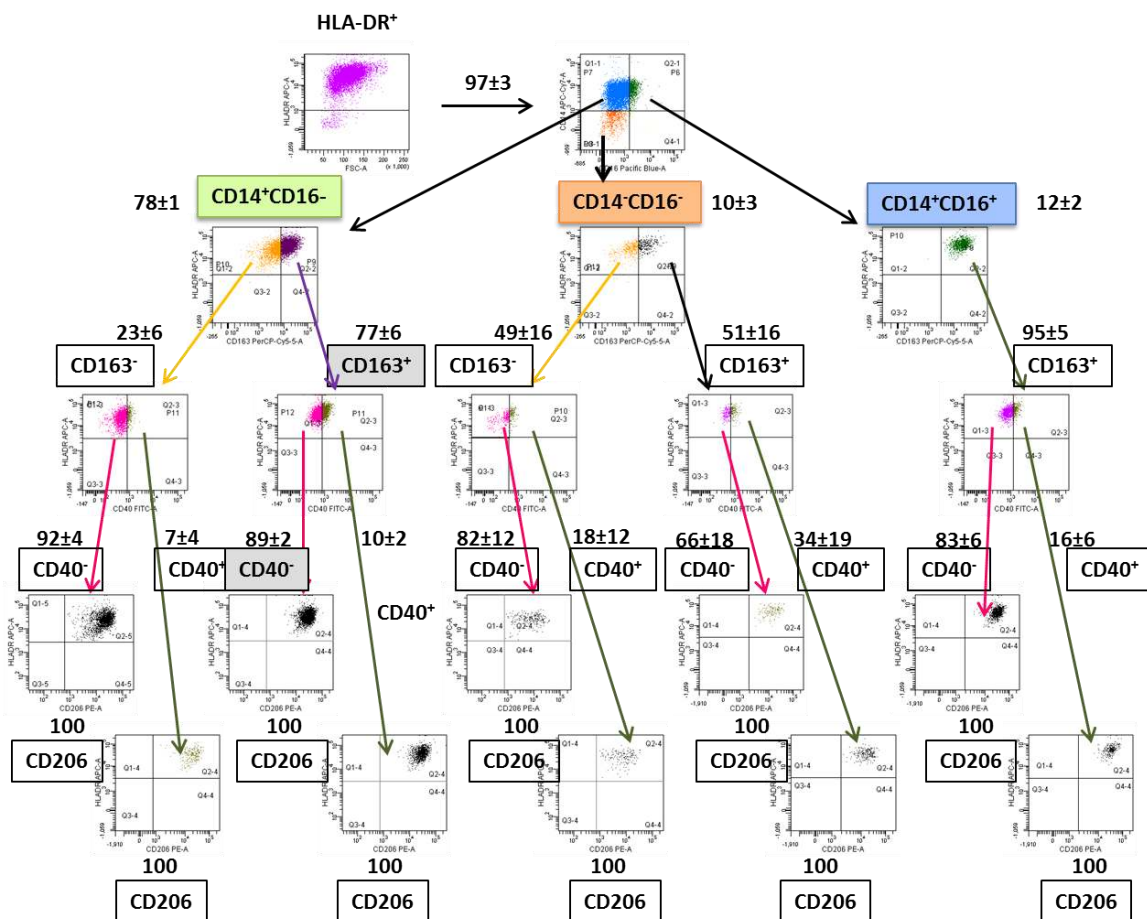

Figure 1

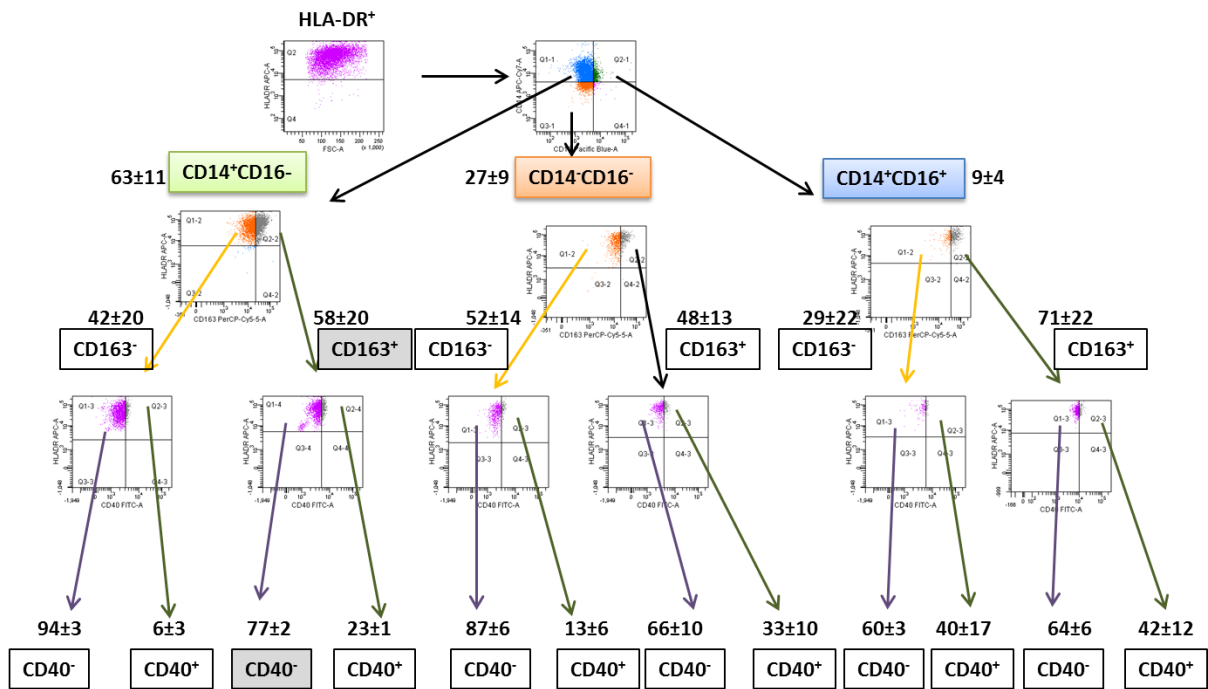

Figure 2

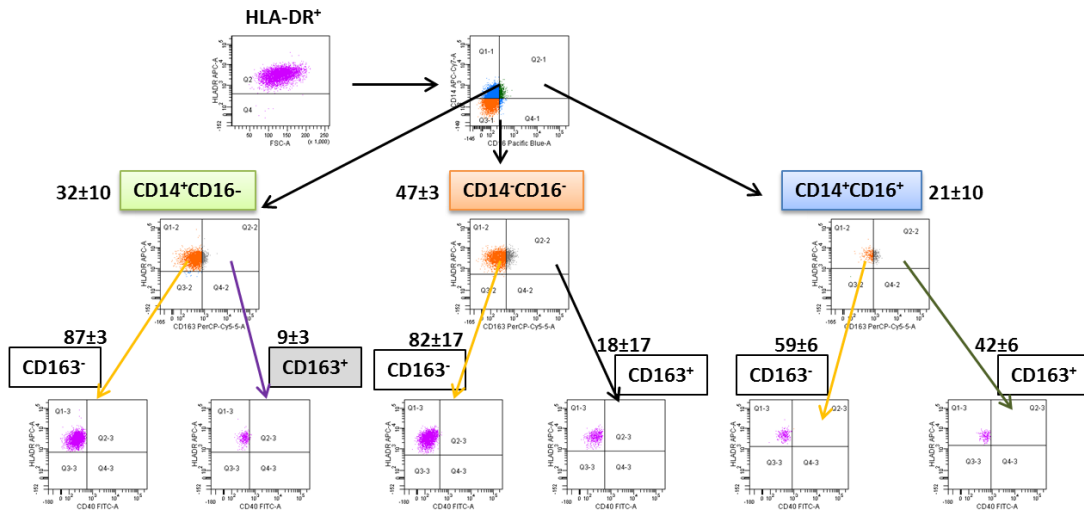

Figure 3

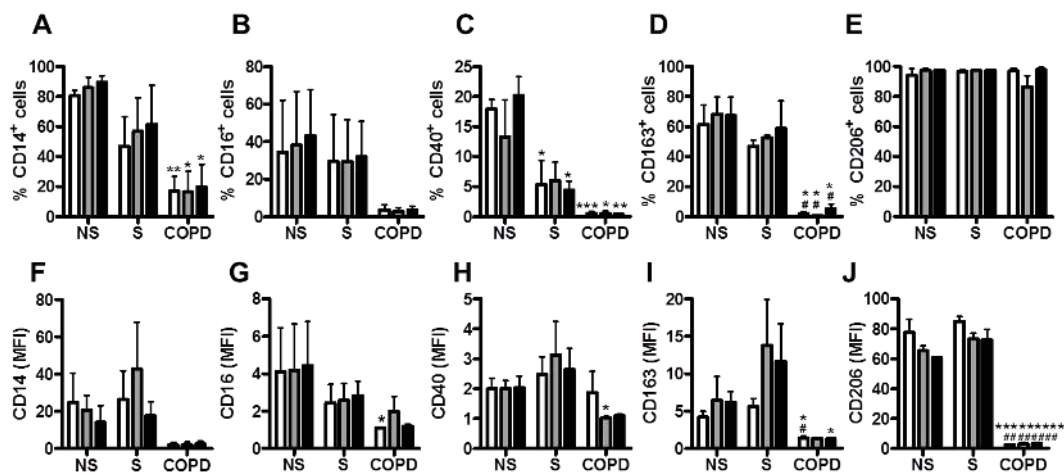

Figure 4

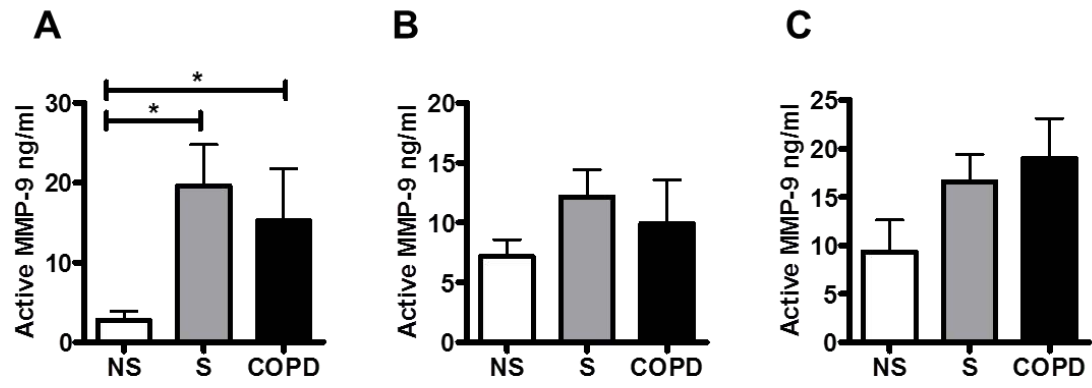

Figure 5

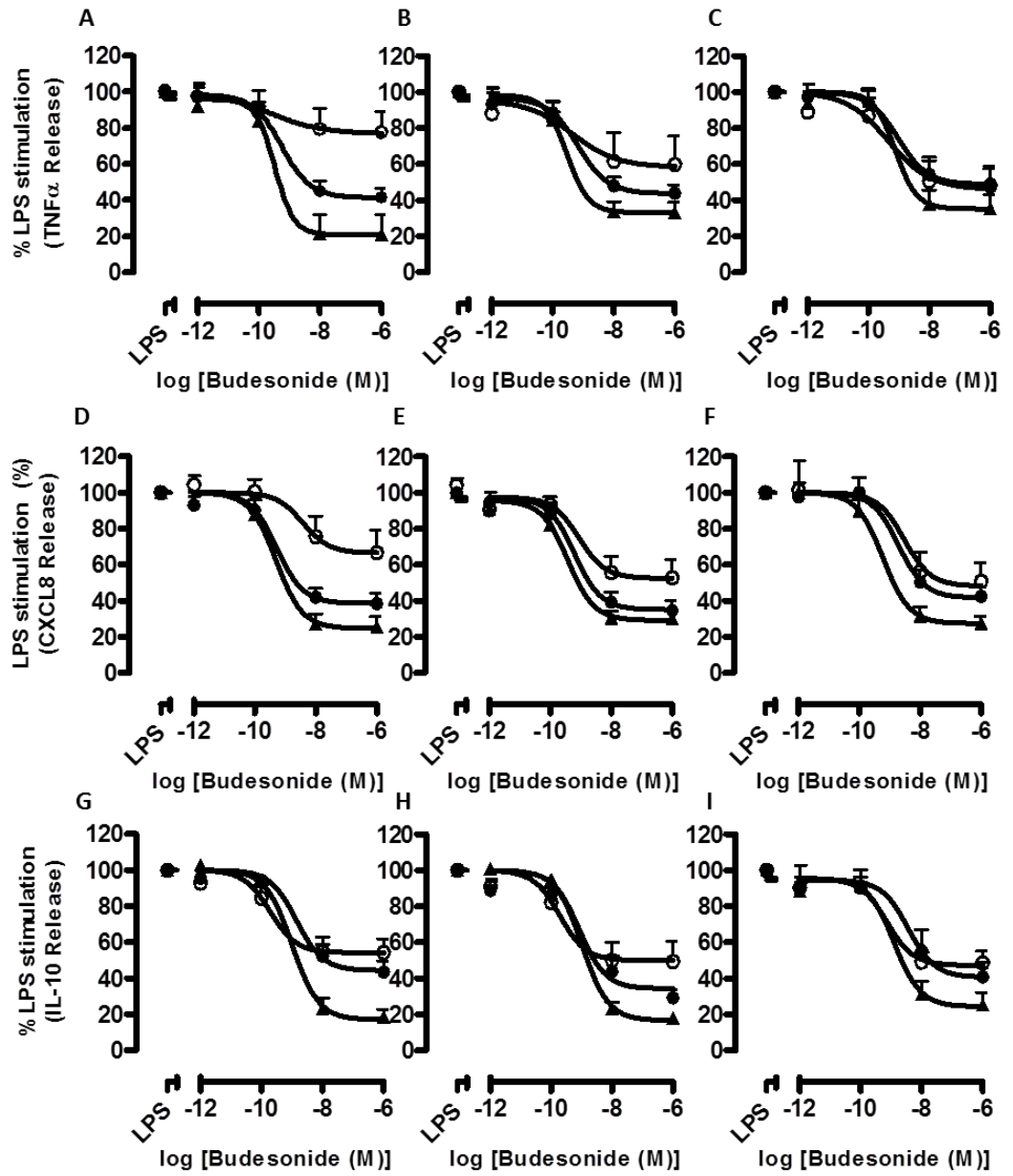

Figure 6

**Online Supplementary data**

**Identification of a distinct glucocorticosteroid-insensitive pulmonary macrophage phenotype in COPD**

Kirandeep K. Chana<sup>1</sup>, Peter S. Fenwick<sup>1</sup>, Andrew G. Nicholson<sup>2</sup>, Peter J. Barnes<sup>1</sup>, Louise E. Donnelly<sup>1</sup>

<sup>1</sup>Airway Disease, National Heart and Lung Institute, Imperial College London, Dovehouse Street, London, SW3 6LY, U.K

<sup>2</sup>Department of Histopathology, Royal Brompton Hospital, Sydney Street, London, SW3 6NP, UK



## Methods

### Isolation of lung tissue macrophages

Macrophages were isolated from lung tissue essentially as described previously<sup>1</sup>. Lung tissue was lavaged by injecting 120ml macrophage media (RPMI 1640 containing 100µg/ml (1%<sup>v/v</sup>) penicillin/streptomycin and 2mM (1%<sup>v/v</sup>) L-glutamine, 0.25µg <sup>w/v</sup> amphotericin B and 50mM EDTA). The flushed media was collected and centrifuged at 300xg for 5 min. The pellet was resuspended in 1ml complete macrophage media (RPMI 1640 containing 10% <sup>v/v</sup> fetal calf serum (FCS), 100µg/ml (1%<sup>v/v</sup>) penicillin/streptomycin, 2mM (1%<sup>v/v</sup>) L-glutamine and 0.25µg (<sup>v/v</sup>) amphotericin B), and separated on a Percoll density gradient. 100% (<sup>v/v</sup>) Percoll was derived by adding 3ml 10x Dulbecco's PBS (D-PBS) to 27ml Percoll. The gradient consisted of six separate concentrations of Percoll prepared as follows: 2ml 60% (<sup>v/v</sup>) Percoll was added to a 15ml Falcon tube. This was overlaid with 2ml 50% (<sup>v/v</sup>) Percoll, 2ml 40% (<sup>v/v</sup>) Percoll, 2ml 30% (<sup>v/v</sup>) Percoll, and 2ml 20% (<sup>v/v</sup>) Percoll. The re-suspended cell pellet was overlaid onto the prepared gradient and centrifuged at 1000xg for 25 min. Fractions at each of the Percoll interfaces were collected into individual tubes and washed with 15ml sterile PBS and 5ml complete media by centrifugation at 300xg for 5 min. The pellet was re-suspended in 10ml complete media, cells counted and seeded onto 96 well plates 10<sup>5</sup> cells/well. Adherent, macrophages were incubated at 37°C, 5% (<sup>v/v</sup>) CO<sub>2</sub> overnight before treatment.

### Flow cytometry

BD CompBead Plus Compensation Particles were used to establish the laser voltages prior to analysing the cell samples using a BD FACS Canto II analyzer. For each fluorochrome, the laser voltages were set to give the best resolution between peaks (i.e between the control, unstained bead and the stained bead). As a starting point, the control peak was set to sit above

$10^{-2}$  on the  $x$ -axis of the histogram, this gave the largest window between the control peak and stained peak. After this had been set for all fluorochromes, the FACSDiva software automatically calculated the amount of spectral overlap between all fluorochromes. If there was an overlap of  $>35\%$  between any two fluorochromes, the voltages were manually altered to reduce the spectral overlap whilst at the same time maintaining good resolution. Only after these voltages were established were the cells passed through the machine.

Cells were blocked using  $1\%(\text{v/v})$  human serum for 15 min at room temperature and centrifuged at  $300g$  for 5 min. HLA-DR-APC ( $2.5\mu\text{g/ml}$ ), CD40-FITC ( $12\mu\text{g/ml}$ ), CD163-PerCP-CY5.5 ( $10\mu\text{g/ml}$ ), CD16-PacificBlue ( $2\mu\text{g/ml}$ ), CD14-APC-CY7 ( $12\mu\text{g/ml}$ ), CD206-PE ( $2.5\mu\text{g/ml}$ ) CD3-PE-Cy7 ( $4\mu\text{g/ml}$ ) and CD1A-PE-CY7 were added in combination, and PBS was added to a final volume of  $100\mu\text{l}$ . Cells were also stained for fluorescence minus one controls (FMO). Cells were incubated for 45 min at  $4^{\circ}\text{C}$  followed by washes with PBS and centrifuged at  $300g$  for 5 min and resuspended in  $400\mu\text{l}$  FACS Fix. The hierarchy of acquisition is shown in Fig. E3 with a minimum of 5000 events acquired for each run.

## Figure Legends

### Figure E1. Gating strategy for multi-parameter flow cytometry.

Dead cells, doublets and CD3<sup>+</sup>, CD1a<sup>+</sup> cells were excluded and the remaining HLA-DR<sup>+</sup> cells were subsequently analysed for CD14 and CD16, followed by CD163, CD40 and CD206.

### Figure E2: QuickDiff staining of tissue macrophages

Nuclei stained dark blue, cytoplasm stained light blue. Cell fractions were extracted from the following Percoll interfaces, A: 30-40% (<sup>v</sup>/<sub>v</sub>), B: 40-50% (<sup>v</sup>/<sub>v</sub>), C: 50-60% (<sup>v</sup>/<sub>v</sub>). Photomicrographs are representative of six tissue samples.

### Figure E3: Expression of CD68 by tissue macrophages.

Cytospins were prepared using human lung macrophages. Cells were fixed and stained using an immunocytochemistry kit with either a CD68 antibody or an isotype control. Slides were then visualized using a light microscope. Cellular staining (haemalum) is purple/blue, CD68 is red/brown. Representative of four separate experiments.

### Figure E4. Cell surface receptor expression of macrophages isolated from the 40-50% (<sup>v</sup>/<sub>v</sub>) Percoll interface from the lung tissue of non-smokers.

Macrophages were isolated at the 40-50% (<sup>v</sup>/<sub>v</sub>) Percoll interface from the lung tissue of non-smokers and cells were blocked with IgG for 15 min at room temperature, and then incubated with APC-HLA-DR, FITC-CD40, PerCP CY5.5-CD163, PE-CD206, APC-CY7-CD14, Pacific Blue CD16 for 45 min at 4°C. Cells were washed, resuspended in FACS fix and analyzed by flow cytometry. HLA-DR<sup>+</sup> cells were selected followed by CD14<sup>+</sup>CD16<sup>-</sup>, CD14<sup>-</sup>CD16<sup>-</sup> and CD14<sup>+</sup>CD16<sup>+</sup>. Each of these CD14 and CD16 populations were then analyzed for

expression of CD163, CD40 and CD206. The percentage of cells isolated from the Percoll interfaces of 40-50% ( $v/v$ ) are presented as mean $\pm$ SEM, n=3. Figure is a representative of n=3 experiments.

**Figure E5. Cell surface receptor expression of macrophages isolated from the 50-60% ( $v/v$ ) Percoll interface from the lung tissue of non-smokers.**

Macrophages were isolated at the 50-60% ( $v/v$ ) Percoll interface from the lung tissue of non-smokers and cells were blocked with IgG for 15 min at room temperature, and then incubated with APC-HLA-DR, FITC-CD40, PerCP CY5.5-CD163, PE-CD206, APC-CY7-CD14, Pacific Blue CD16 for 45 min at 4°C. Cells were washed, resuspended in FACS fix and analyzed by flow cytometry. HLA-DR+ cells were selected followed by CD14<sup>+</sup>CD16<sup>-</sup>, CD14<sup>-</sup>CD16<sup>-</sup> and CD14<sup>+</sup>CD16<sup>+</sup>. Each of these CD14 and CD16 populations were then analyzed for expression of CD163, CD40 and CD206. The percentage of cells isolated from the Percoll interfaces of 50-60% ( $v/v$ ) are presented as mean $\pm$ SEM, n=3. Figure is a representative of n=3 experiments.

**Figure E6. Cell surface receptor expression of macrophages isolated from the 40-50% ( $v/v$ ) Percoll interface from the lung tissue of smokers.**

Macrophages were isolated at the 40-50% ( $v/v$ ) Percoll interface from the lung tissue of smokers and cells were blocked with IgG for 15 min at room temperature, and then incubated with APC-HLA-DR, FITC-CD40, PerCP CY5.5-CD163, PE-CD206, APC-CY7-CD14, Pacific Blue CD16 for 45 min at 4°C. Cells were washed, resuspended in FACS fix and analyzed by flow cytometry. HLA-DR+ cells were selected followed by CD14<sup>+</sup>CD16<sup>-</sup>, CD14<sup>-</sup>CD16<sup>-</sup> and CD14<sup>+</sup>CD16<sup>+</sup>. Each of these CD14 and CD16 populations were then analyzed for expression of CD163, CD40 and CD206. The percentage of cells isolated from the Percoll

interfaces of 40-50% ( $\nu/\nu$ ) are presented as mean $\pm$ SEM, n=3. Figure is a representative of n=3 experiments.

**Figure E7. Cell surface receptor expression of macrophages isolated from the 50-60% ( $\nu/\nu$ ) Percoll interface from the lung tissue of smokers.**

Macrophages were isolated at the 50-60% ( $\nu/\nu$ ) Percoll interface from the lung tissue of smokers and cells were blocked with IgG for 15 min at room temperature, and then incubated with APC-HLA-DR, FITC-CD40, PerCP CY5.5-CD163, PE-CD206, APC-CY7-CD14, Pacific Blue CD16 for 45 min at 4°C. Cells were washed, resuspended in FACS fix and analyzed by flow cytometry. HLA-DR<sup>+</sup> cells were selected followed by CD14<sup>+</sup>CD16<sup>-</sup>, CD14<sup>-</sup>CD16<sup>-</sup> and CD14<sup>+</sup>CD16<sup>+</sup>. Each of these CD14 and CD16 populations were then analyzed for expression of CD163, CD40 and CD206. The percentage of cells isolated from the Percoll interfaces of 50-60% ( $\nu/\nu$ ) are presented as mean $\pm$ SEM, n=3. Figure is a representative of n=3 experiments.

**Figure E8. Cell surface receptor expression of macrophages isolated from the 40-50% ( $\nu/\nu$ ) Percoll interface from the lung tissue of COPD patients.**

Macrophages were isolated at the 40-50% ( $\nu/\nu$ ) Percoll interface from the lung tissue of COPD patients and cells were blocked with IgG for 15 min at room temperature, and then incubated with APC-HLA-DR, FITC-CD40, PerCP CY5.5-CD163, PE-CD206, APC-CY7-CD14, Pacific Blue CD16 for 45 min at 4°C. Cells were washed, resuspended in FACS fix and analyzed by flow cytometry. HLA-DR<sup>+</sup> cells were selected followed by CD14<sup>+</sup>CD16<sup>-</sup>, CD14<sup>-</sup>CD16<sup>-</sup> and CD14<sup>+</sup>CD16<sup>+</sup>. Each of these CD14 and CD16 populations were then analyzed for expression of CD163, CD40 and CD206. The percentage of cells isolated from the Percoll interfaces of 40-50% ( $\nu/\nu$ ) are presented as mean $\pm$ SEM, n=3. Figure is a representative of n=3 experiments.

**Figure E9. Cell surface receptor expression of macrophages isolated from the 50-60% ( $v/v$ ) Percoll interface from the lung tissue of COPD patients.**

Macrophages were isolated at the 50-60% ( $v/v$ ) Percoll interface from the lung tissue of smokers and cells were blocked with IgG for 15 min at room temperature, and then incubated with APC-HLA-DR, FITC-CD40, PerCP CY5.5-CD163, PE-CD206, APC-CY7-CD14, Pacific Blue CD16 for 45 min at 4°C. Cells were washed, resuspended in FACS fix and analyzed by flow cytometry. HLA-DR<sup>+</sup> cells were selected followed by CD14<sup>+</sup>CD16<sup>-</sup>, CD14<sup>-</sup>CD16<sup>-</sup> and CD14<sup>+</sup>CD16<sup>+</sup>. Each of these CD14 and CD16 populations were then analyzed for expression of CD163, CD40 and CD206. The percentage of cells isolated from the Percoll interfaces of 50-60% ( $v/v$ ) are presented as mean $\pm$ SEM, n=3. Figure is a representative of n=3 experiments.

	Non-smokers (n=4)		Smokers (n=19)		COPD (n=4)	
Percoll fraction (%)	M $\theta$ x 10 <sup>6</sup> /g tissue	% total M $\theta$	M $\theta$ x 10 <sup>6</sup> /g tissue	% total M $\theta$	M $\theta$ x 10 <sup>6</sup> /g tissue	% total M $\theta$
<b>30-40</b>	1.9 $\pm$ 0.6	34.9 $\pm$ 4.0	4.7 $\pm$ 0.9	41.2 $\pm$ 3.8	3.3 $\pm$ 1.7	23.9 $\pm$ 3.7
<b>40-50</b>	2.2 $\pm$ 0.8	34.4 $\pm$ 1.7	4.0 $\pm$ 0.6	37.6 $\pm$ 1.4	1.6 $\pm$ 0.4	28.1 $\pm$ 1.6
<b>50-60</b>	0.8 $\pm$ 0.5	33.6 $\pm$ 3.0	2.5 $\pm$ 0.4*	37.2 $\pm$ 1.9	0.8 $\pm$ 0.4	29.2 $\pm$ 2.7

**Table E1. Distribution of macrophages in each fraction**

Resected lung tissue was weighed and macrophages (M $\theta$ ) were isolated from the 30-40% ( $v/v$ ), 40-50% ( $v/v$ ) and 50-60% ( $v/v$ ) interfaces of the Percoll gradient from non-smokers, smokers and COPD patients. Cells were stained using Kimura dye and counted. Data are presented as mean  $\pm$  SEM. \* $p$ <0.05 vs non-smokers and COPD patients.

#### References

1. Finney-Hayward TK, Popa O, Bahra P, Li S, Poll CT, Gosling M, et al. Expression of TRPC6 Channels in Human Lung Macrophages. *Am. J. Respir. Cell Mol. Biol.* 2010; 43:296-304.

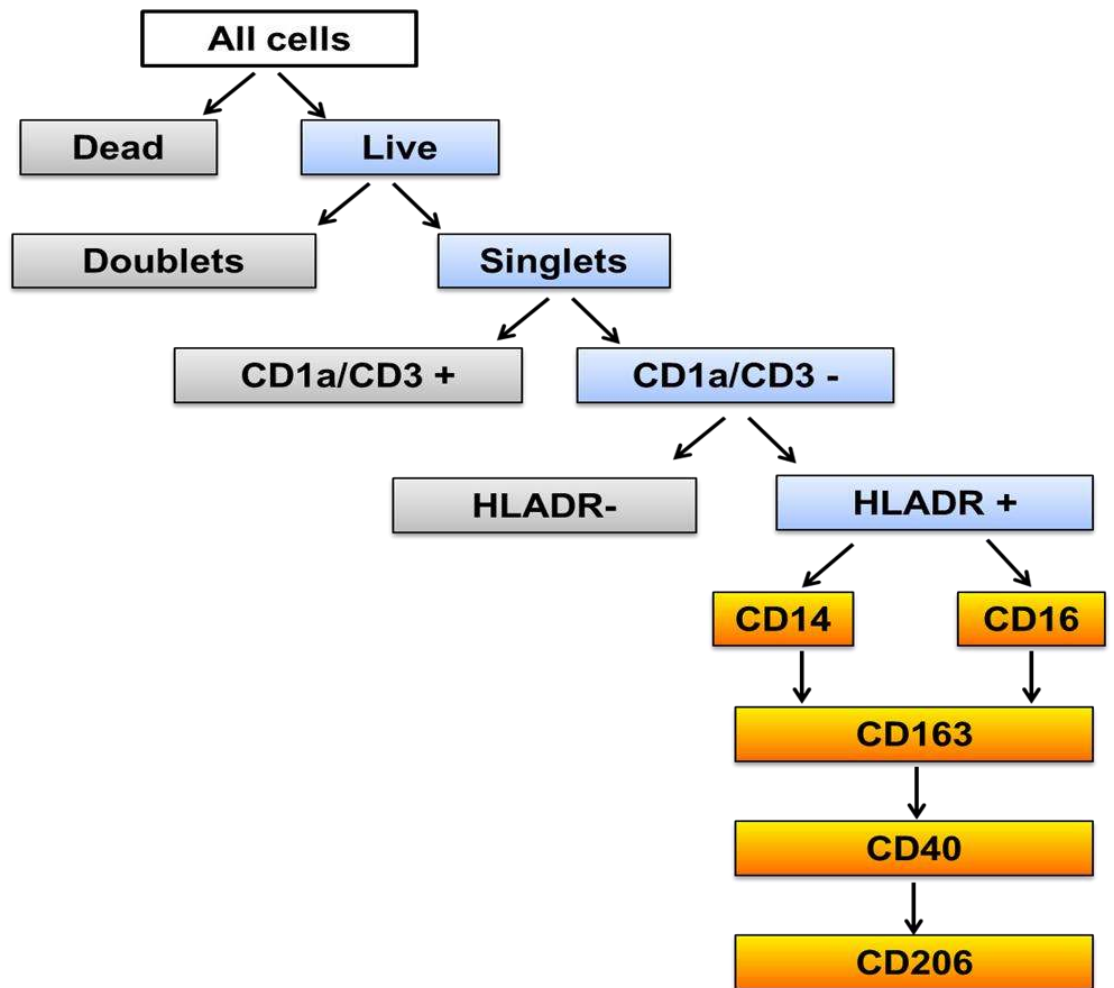

Figure E1



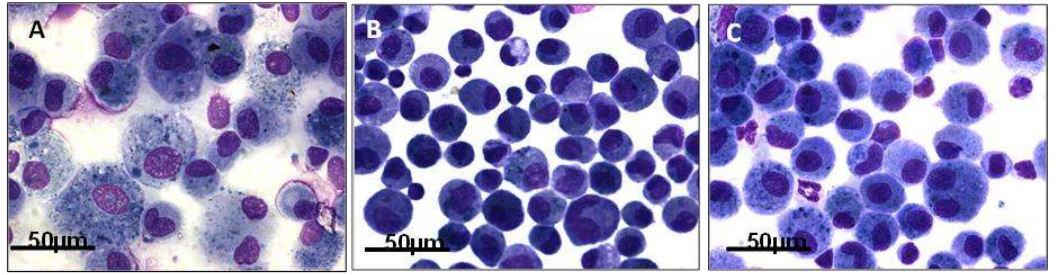

Figure E2

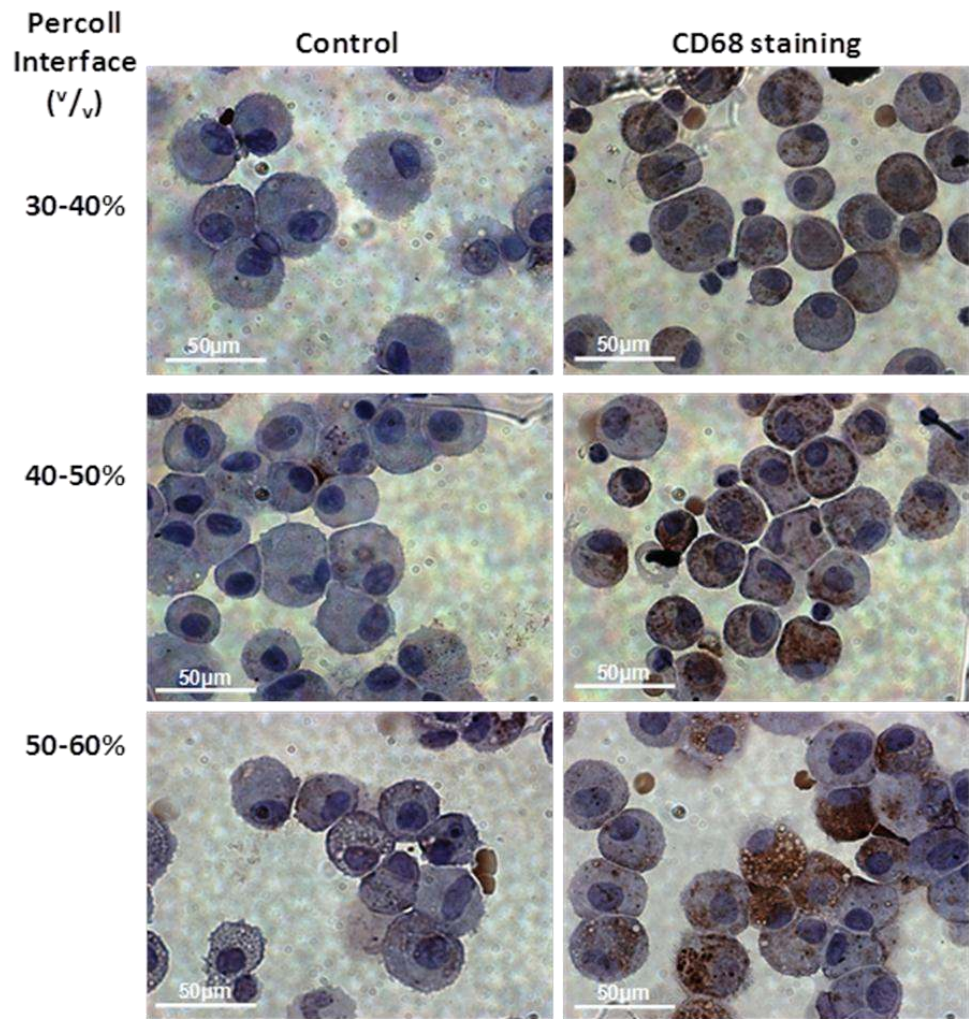

Figure E3

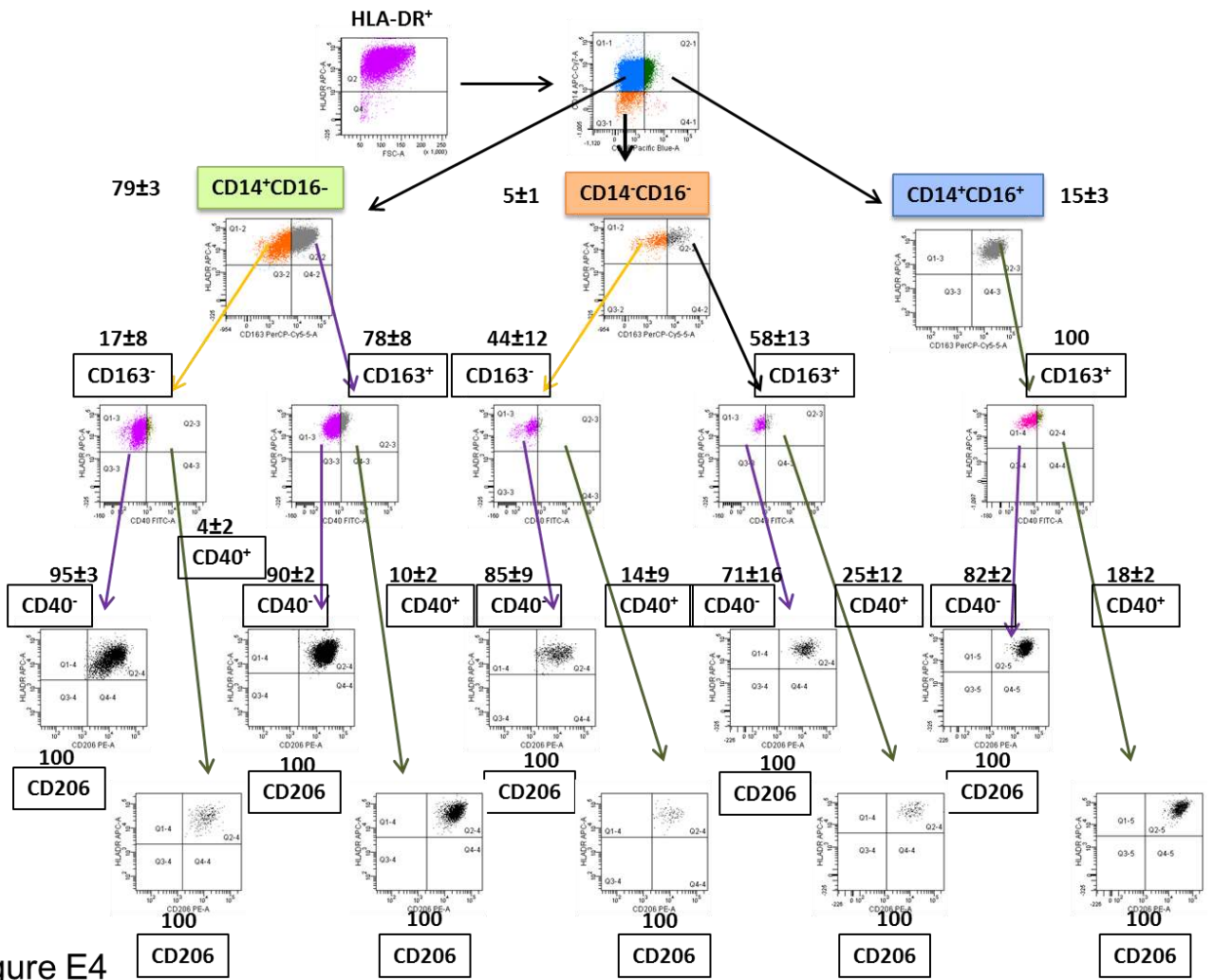

Figure E4

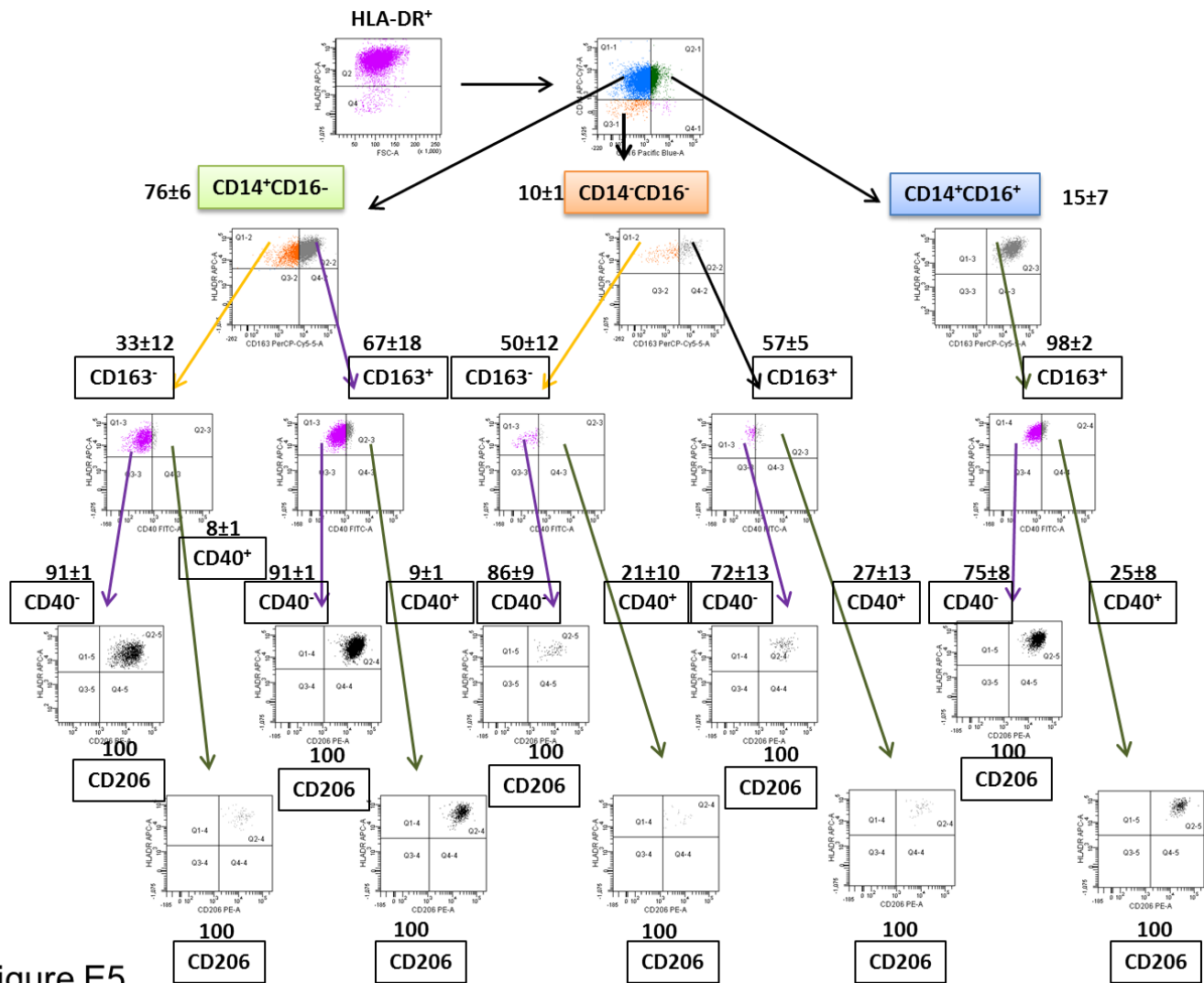

Figure E5



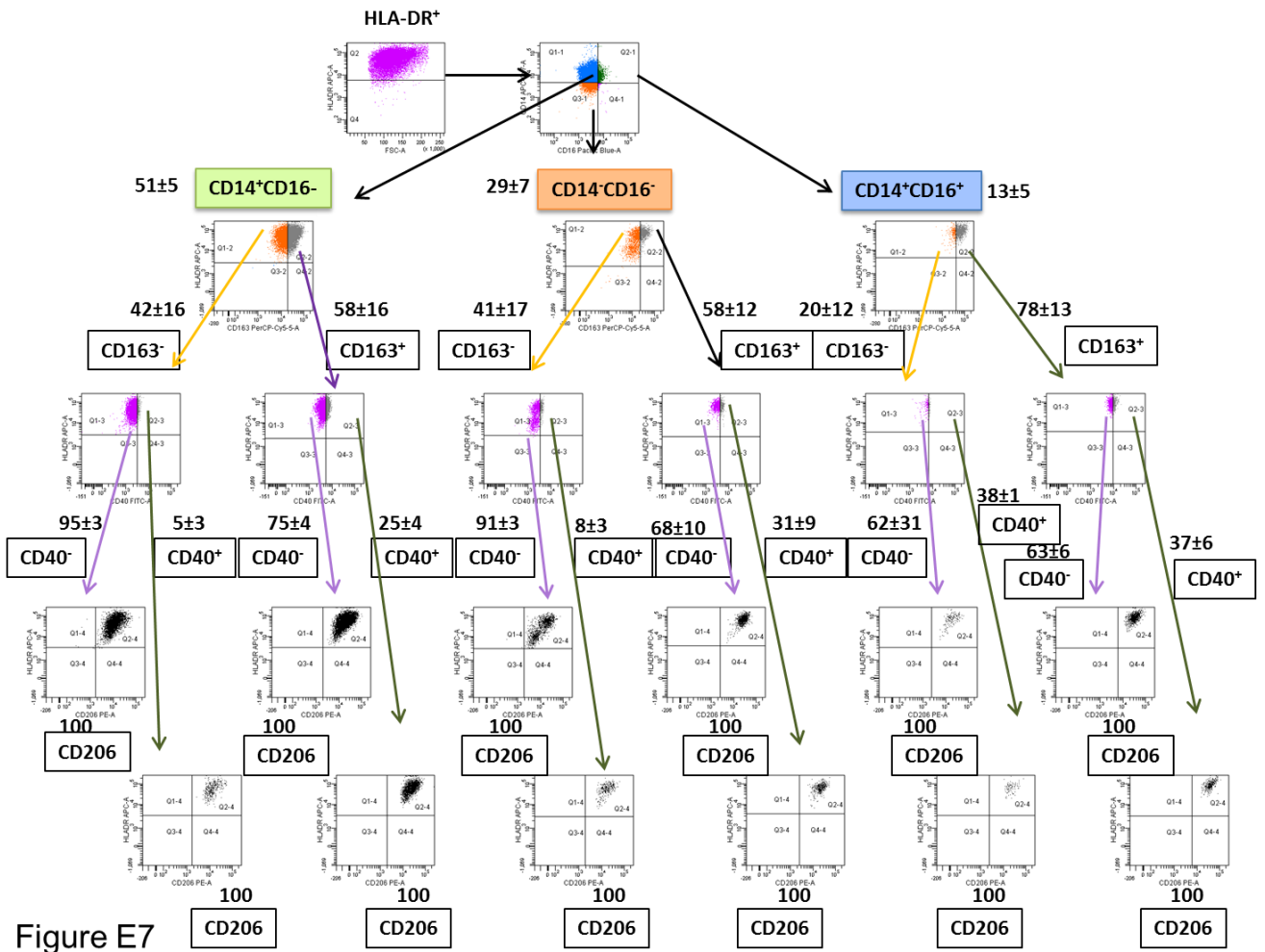

Figure E7

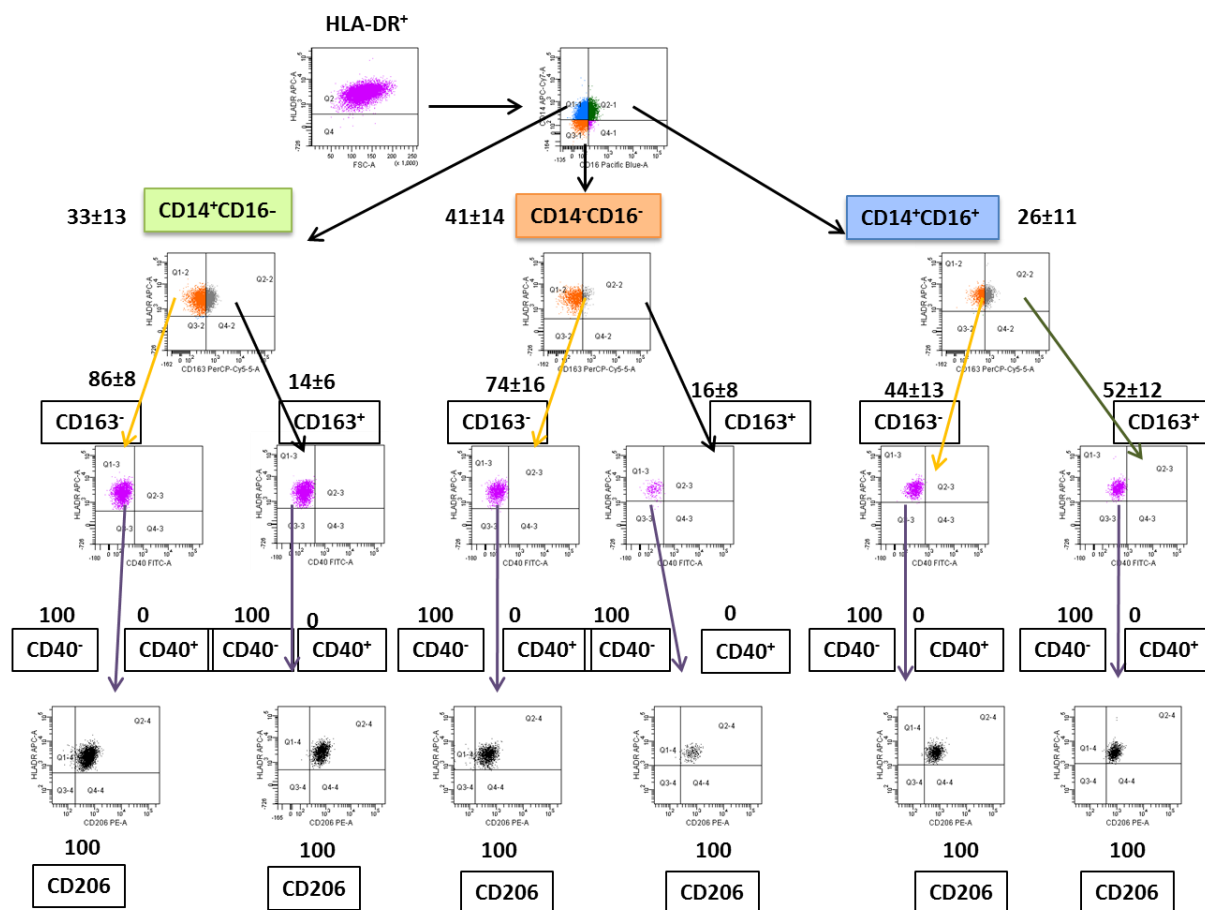

Figure E8



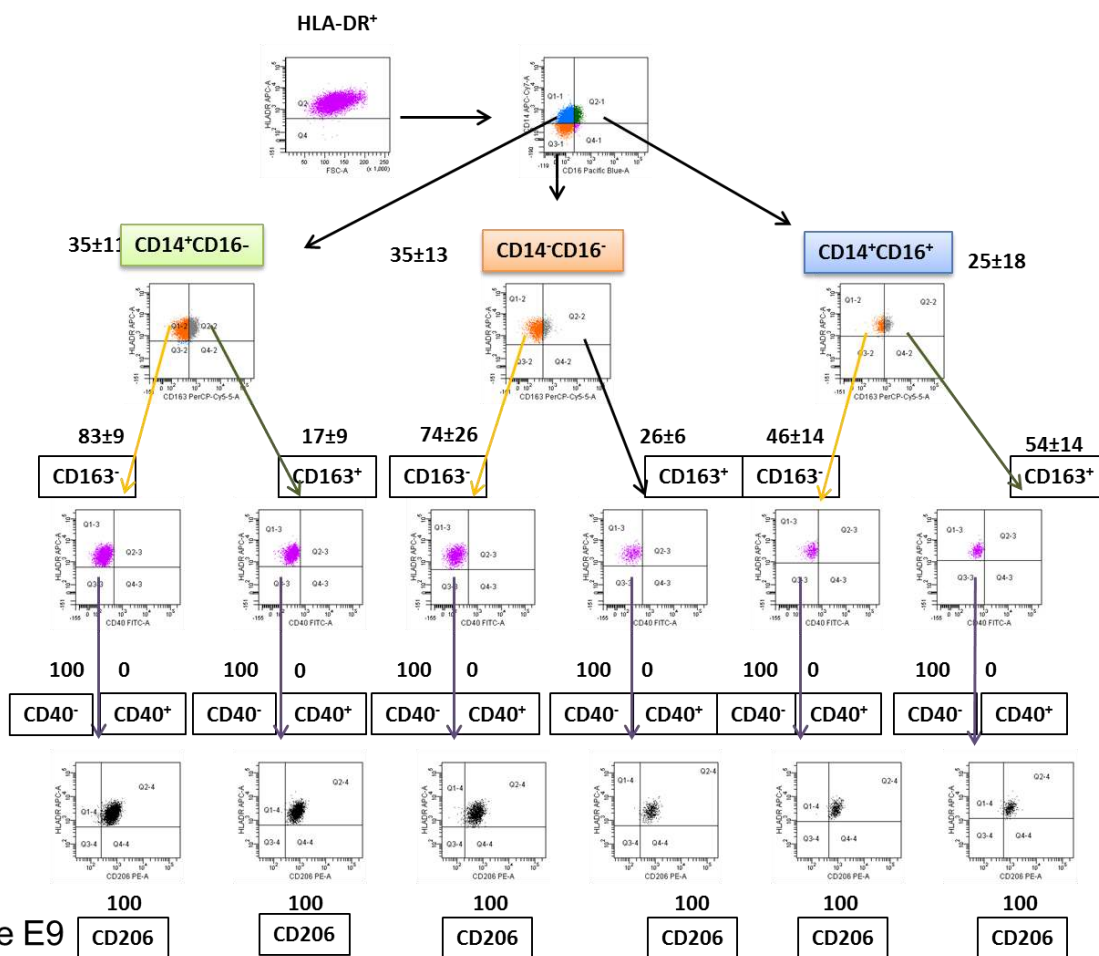

Figure E9