

University of Wollongong

Research Online

Faculty of Science, Medicine and Health -
Papers: Part B

Faculty of Science, Medicine and Health

1-1-2014

Identification of the linkage group of the Z sex chromosomes of the sand lizard (*Lacerta agilis*, Lacertidae) and elucidation of karyotype evolution in lacertid lizards

Kornsorn Srikulnath

Nagoya University, Kasetsart University

Kazumi Matsubara

University of Canberra

Yoshinobu Uno

Nagoya University

Chizuko Nishida

Hokkaido University

Mats M. Olsson

University of Sydney, molsson@uow.edu.au

See next page for additional authors

Follow this and additional works at: <https://ro.uow.edu.au/smhpapers1>

Publication Details Citation

Srikulnath, K., Matsubara, K., Uno, Y., Nishida, C., Olsson, M. M., & Matsuda, Y. (2014). Identification of the linkage group of the Z sex chromosomes of the sand lizard (*Lacerta agilis*, Lacertidae) and elucidation of karyotype evolution in lacertid lizards. Faculty of Science, Medicine and Health - Papers: Part B. Retrieved from <https://ro.uow.edu.au/smhpapers1/993>

Research Online is the open access institutional repository for the University of Wollongong. For further information contact the UOW Library: research-pubs@uow.edu.au

Identification of the linkage group of the Z sex chromosomes of the sand lizard (*Lacerta agilis*, Lacertidae) and elucidation of karyotype evolution in lacertid lizards

Abstract

The sand lizard (*Lacerta agilis*, Lacertidae) has a chromosome number of $2n = 38$, with 17 pairs of acrocentric chromosomes, one pair of microchromosomes, a large acrocentric Z chromosome, and a micro-W chromosome. To investigate the process of karyotype evolution in *L. agilis*, we performed chromosome banding and fluorescent in situ hybridization for gene mapping and constructed a cytogenetic map with 86 functional genes. Chromosome banding revealed that the Z chromosome is the fifth largest chromosome. The cytogenetic map revealed homology of the *L. agilis* Z chromosome with chicken chromosomes 6 and 9. Comparison of the *L. agilis* cytogenetic map with those of four Toxicofera species with many microchromosomes (*Elaphe quadrivirgata*, *Varanus salvator macromaculatus*, *Leiolepis reevesii rubritaeniata*, and *Anolis carolinensis*) showed highly conserved linkage homology of *L. agilis* chromosomes (LAG) 1, 2, 3, 4, 5(Z), 7, 8, 9, and 10 with macrochromosomes and/or macrochromosome segments of the four Toxicofera species. Most of the genes located on the microchromosomes of Toxicofera were localized to LAG6, small acrocentric chromosomes (LAG11-18), and a microchromosome (LAG19) in *L. agilis*. These results suggest that the *L. agilis* karyotype resulted from frequent fusions of microchromosomes, which occurred in the ancestral karyotype of Toxicofera and led to the disappearance of microchromosomes and the appearance of many small macrochromosomes.

Publication Details

Srikulnath, K., Matsubara, K., Uno, Y., Nishida, C., Olsson, M. & Matsuda, Y. (2014). Identification of the linkage group of the Z sex chromosomes of the sand lizard (*Lacerta agilis*, Lacertidae) and elucidation of karyotype evolution in lacertid lizards. *Chromosoma: biology of the nucleus*, 123 (6), 563-575.

Authors

Kornsorn Srikulnath, Kazumi Matsubara, Yoshinobu Uno, Chizuko Nishida, Mats M. Olsson, and Yoichi Matsuda

Identification of the linkage group of the Z sex chromosomes of the sand lizard (*Lacerta agilis*, Lacertidae) and elucidation of karyotype evolution in lacertid lizards

Kornsorn Srikulnath & Kazumi Matsubara & Yoshinobu Uno & Chizuko Nishida & Mats Olsson & Yoichi Matsuda

Abstract The sand lizard (*Lacerta agilis*, Lacertidae) has a chromosome number of $2n=38$, with 17 pairs of acrocentric chromosomes, one pair of microchromosomes, a large acrocentric Z chromosome, and a micro-W chromosome. To investigate the process of karyotype evolution in

L. agilis, we performed chromosome banding and fluorescent in situ hybridization for gene mapping and constructed a cytogenetic map with 86 functional genes. Chromosome banding revealed that the Z chromosome is the fifth largest chromosome. The cytogenetic map revealed homology of the *L. agilis* Z chromosome with chicken chromosomes 6 and 9. Comparison of the *L. agilis* cytogenetic map with those of four Toxicofera species with many microchromosomes (*Elaphe quadrivirgata*, *Varanus salvator macromaculatus*, *Leiolepis reevesii rubritaeniata*, and *Anolis carolinensis*) showed highly conserved linkage homology of *L. agilis* chromosomes (LAG) 1, 2, 3, 4, 5(Z), 7, 8, 9, and 10 with macrochromosomes and/or macrochromosome segments of the four Toxicofera species. Most of the genes located on the microchromosomes of Toxicofera were localized to LAG6, small acrocentric chromosomes (LAG11–18), and a microchromosome (LAG19) in *L. agilis*. These results suggest that the *L. agilis* karyotype resulted from frequent fusions of microchromosomes, which occurred in the ancestral karyotype of Toxicofera and led to the disappearance of microchromosomes and the appearance of many small macrochromosomes.

Introduction

Comparison of the draft genome assembly of the green anole (*Anolis carolinensis*) with the genome sequence of chicken (*Gallus gallus*) suggested a high level of conservation of the genetic linkages between the two species (ICGSC 2004; Alföldi et al. 2011). This genome information provided a new perspective on the comparative genomics of Reptilia and Aves, which in turn facilitated extensive comparison of genomic structures between the two taxa at the molecular level. Chromosome maps that compared each of the Chinese soft-shelled turtle (*Pelodiscus sinensis*), Siamese crocodile (*Crocodylus siamensis*), water monitor lizard (*Varanus salvator macromaculatus*), Japanese four-striped rat snake (*Elaphe quadrivirgata*), and butterfly lizard (*Leiolepis reevesii rubritaeniata*) with the chicken revealed a high level of conservation of chromosomes among the members of Aves, Testudines, Crocodylia, and Squamata (Matsuda et al. 2005; Matsubara et al. 2006, 2012; Srikulnath et al. 2009b, 2013; Uno et al. 2012) since the time when the Sauropsida (all existing reptiles and birds) diverged from the Synapsida around 320 million years ago (MYA), based on the dating of Shedlock and Edwards (2009).

Reptiles display considerable diversity in their sex chromosomes and the systems they use for sex determination. Whereas all crocodylians, the tuatara, most turtles, and some lizards have temperature-dependent systems that determine sex (Head et al. 1987; Lang and Andrews 1994; Cree et al. 1995; Ciofi and Swingland 1997), almost all snakes (Serpentes) exhibit genotypic sex determination (GSD); whereas most snakes have morphologically differentiated ZZ/ZW-type sex chromosomes, and many lizards and some turtles exhibit GSD with both male and female heterogamety (XY, X_1X_2Y , ZW, and Z_1Z_2W) (Olmo and Signorino 2005). However, the origin of the sex chromosomes in reptiles and the processes by which they differentiated are poorly understood owing to the limited number of species for which sex-linked genes have been identified. Cytogenetic maps that compare the chicken with each of two turtle species, the black marsh turtle (*Siebenrockiella crassicolis*) and *P. sinensis*, indicated that the *S. crassicolis* X chromosome corresponds to chicken chromosome 5 and that the *P. sinensis* Z sex chromosome corresponds to chicken chromosome 15 (Kawagoshi et al. 2009, 2012). In squamate reptiles, such as snakes, the origins of the sex chromosomes differ from those of the chicken Z chromosome, although snake sex chromosomes use the ZZ/ZW system found in birds (Matsubara et al. 2006, 2012). A cytogenetic map that compared *E. quadrivirgata* (Serpentes) with chicken revealed that, whereas the chicken Z-linked genes were localized to the short arm of snake chromosome 2, the chicken homologs of the snake Z-linked genes were

localized to chicken chromosomes 2 and 27 (Matsubara et al. 2006, 2012). The micro-X chromosome of *A. carolinensis* (Iguania) is homologous to chicken chromosome 15, which corresponds to the *P. sinensis* Z chromosome (Alföldi et al. 2011). Moreover, the Z chromosome of the Hokou gecko (*Gekko hokouensis*, Gekkota) has homology with the chicken Z chromosome (Kawai et al. 2009). These results collectively suggest that independent differentiation of sex chromosomes in each lineage of reptiles resulted in them using different systems for the genetic determination of sex.

Compared with avian and testudine species, the karyotypes of squamate species are relatively diverse, in terms of both their chromosome number ($2n=30-50$) and their chromosome morphology (Olmo and Signorino 2005). In squamate reptiles, macro and microchromosomes are commonly found in the Dibamidae, Scincoidea, and Episquamata (Toxicofera and Lacertoidea), excluding the Lacertidae (Olmo and Signorino 2005; Pyron et al. 2013). In our previous studies (Srikulnath et al. 2009b, 2013), we compared the chromosomal locations of 86 functional genes among three Toxicofera species [*E. quadrivirgata* (Serpentes), *V. salvator macromaculatus* (Anguimorpha), and *L. reevesii rubritaeniata* (Iguania)] (Vidal and Hedges 2005; Pyron et al. 2013) and revealed that most macrochromosomes were homologous. Nonetheless, these studies revealed several chromosomal rearrangements among the species. The rearrangements included centric fission/fusion of macrochromosomes, telomere-to-telomere tandem fusion between macrochromosomes and between macro and microchromosomes, and centromere repositioning. By contrast, few or no microchromosomes are found in the Lacertidae of Lacertoidea and Gekkota. The observation that the karyotype of Lacertidae (lacertid lizards) usually has only one pair of microchromosomes (Odierna et al. 1993; Olmo and Signorino 2005) leads us to suppose that microchromosomes in this lineage disappeared as a consequence of fusions between macro and microchromosomes and/or between microchromosomes. However, there have been no reports that confirm this. Comparative gene mapping between lacertid lizards and other squamate reptiles of the Toxicofera clade is required to clarify the process of karyotype evolution, including the dynamic reorganization of microchromosomes in Squamata.

Lacertid lizards (Lacertidae, Lacertoidea), which comprise 40 genera with 318 species (Uetz 2014), inhabit Africa and almost the whole of Eurasia. The diploid chromosome number of most lacertid lizards is 38; this comprises 10 pairs of large acrocentric chromosomes, eight pairs of small acrocentric chromosomes, and one pair of microchromosomes (Olmo and Signorino 2005). Most lacertid lizards exhibit a GSD system with ZW-type female heterogamety (Ezaz et al. 2010). The W chromosome exhibits various stages of differentiation in this lineage. Whereas almost all lacertid lizards have large acrocentric Z and W chromosomes, the sand lizard (*Lacerta agilis*) has a large acrocentric Z chromosome and a micro-W chromosome (Odierna et al. 1993; Olmo and Signorino 2005).

In this study, we first performed chromosome banding and fluorescent in situ hybridization (FISH) with the 18S–28S and 5S ribosomal RNA (rRNA) genes to identify the sex chromosomes of *L. agilis* precisely. We also used FISH mapping of functional genes to construct a comparative cytogenetic map of *L. agilis* and examined the homology of the *L. agilis* chromosomes with the chromosomes of other Toxicofera species (*E. quadrivirgata*, *V. salvator macromaculatus*, *L. reevesii rubritaeniata*, and *A. carolinensis*) as well as the chicken. Our comparative mapping data enabled us to both identify the Z-linked genes of *L. agilis* and delineate the process of karyotype evolution in the lineage of Lacertidae.

Materials and methods

Specimens, cell culture, and chromosome preparation

The one male and one female *L. agilis* specimens analyzed were each captured in Asketunnan, which is situated ca. 50 km south of Gothenburg on the west coast of Sweden. After intraperitoneal injection of pentobarbital, the heart, lungs, and mesentery of each animal were removed and used for cell culture. The sex of each animal was identified morphologically and confirmed by its internal anatomy. All experimental procedures using animals conformed to guidelines established by the Animal Care and Use Committee, Nagoya University, Japan. The tissues were minced and cultured in Dulbecco's modified Eagle's medium (Life Technologies-Gibco, Carlsbad, CA, USA) that was supplemented with 15 % fetal bovine serum (Life Technologies-Gibco), 100 µg/mL kanamycin, and 1 % antibiotic-antimycotic (Life Technologies-Gibco). The cultures were incubated at 26 °C in a humidified atmosphere of 5 % CO₂ in air. Primary cultured fibroblasts were harvested using trypsin and then subcultured. For chromosome preparation, fibroblasts at the logarithmic phase of the growth cycle were incubated with 5-bromo-2'-deoxyuridine (12 µg/mL) (Sigma-Aldrich, St. Louis, MO, USA) for 12 h, including 45 min of treatment with colcemid (120 ng/mL) (Nacalai Tesque, Kyoto, Japan) before harvesting. Chromosome preparations were made using a standard air-drying method. For replication banding, the slides were stained with Hoechst 33258 (1 µg/mL) for 8 min, heated at 65 °C for 3 min, and then exposed to ultraviolet light at 65 °C for an additional 6 min (Matsuda and Chapman 1995). The slides were kept at –80 °C until use.

Molecular cloning of cDNA functional gene fragments The cDNA fragments of 30 functional genes were cloned from a male *L. agilis* using the PCR primers shown in Supplementary Table 1. Testes were homogenized and lysed with TRIzol

Reagent (Life Technologies, Carlsbad, CA, USA), and total RNA was extracted following the manufacturer's instructions. The cDNA fragments were obtained by RT-PCR using Oligo(dT)₁₂₋₁₈ Primer and SuperScript II RNase H⁻ Reverse Transcriptase (Life Technologies) and used as PCR templates to amplify *L. agilis* homologs of *L. reevesii rubritaeniata* and *E. quadrivirgata* genes that were mapped in our previous studies (Matsubara et al. 2006, 2012; Srikulnath et al. 2009b). The cDNA amplification was carried out in 20 µl of 1× ExTaq buffer that contained 1.5 mM MgCl₂, 0.2 mM dNTPs, 5.0 µM degenerate primers, and 0.25 U of TaKaRa Ex Taq (Takara Bio, Otsu, Japan). The temperature conditions used for PCR involved an initial denaturation step at 94 °C for 2 min; followed by 35 cycles that each involved incubation at 94 °C for 30 s, 52 °C for 30 s, and 72 °C for 35 s; and a final extension step at 72 °C for 10 min. The PCR products were cloned using pGEM-T Easy Vector System I (Promega, Madison, WI, USA). Nucleotide sequences of the cDNA fragments were determined using an ABI 3130 Automated Capillary DNA Sequencer (Life Technologies-Applied Biosystems, Carlsbad, CA, USA). The nucleotide sequences were used to search for homologies with those of the chicken in the National Center for Biotechnology Information (NCBI) database using the BLASTx and BLASTn programs (<http://blast.ncbi.nlm.nih.gov/Blast.cgi>) and were deposited in the DNA Data Bank of Japan (<http://www.ddbj.nig.ac.jp/index-e.html>) (Table 1). All cDNA fragments were confirmed to be homologs of chicken genes.

FISH mapping

The chromosomal locations of 86 functional genes and the 18S–28S and 5S rRNA genes were determined by FISH, as previously described (Matsuda and Chapman 1995; Srikulnath et al. 2009a), using cDNA fragments cloned from *L. agilis* (30 genes), *L. reevesii rubritaeniata* (54 genes; Srikulnath et al. 2009a, b), *G. hokouensis* (one gene; Srikulnath et al., unpublished data), and *E. quadrivirgata* (one gene; Matsubara et al., unpublished data) (Table 1), a partial 1.8-kb genomic DNA fragment (pCSI1) of the 8.2-kb fragment (EU727190) of *C. siamensis* 18S–28S rRNA genes, and a 99-base-pair (bp) genomic DNA fragment (pCSI5S; EU723235) of *C. siamensis* 5S rRNA genes.

We labeled 250 ng of the 18S–28S rDNA probe with biotin-16-dUTP (Roche Diagnostics, Basel, Switzerland) by nick translation following the manufacturer's protocol (Roche Diagnostics). After hybridization of biotin-labeled 18S–28S rRNA to both male and female *L. agilis* chromosomes, the probes were stained with avidin labeled with fluorescein isothiocyanate (avidin-FITC; Vector Laboratories, Burlingame, CA, USA). Slides were subsequently counterstained with 0.75 µg/mL propidium iodide (PI). For chromosomal localization of functional genes and the 5S rRNA genes, we hybridized biotin-labeled cDNA fragments and 5S rDNA probe to *L. agilis* chromosomes. After hybridization, the probes were reacted with goat anti-biotin antibody (Vector Laboratories) and stained with Alexa Fluor® 488 rabbit anti-goat IgG (H+ L) conjugate (Life Technologies-Molecular Probes).

Results

The karyotype of *Lacerta agilis*

We examined more than 10 Hoechst-stained metaphase spreads of one male and one female *L. agilis*. Chromosome numbers were 2n= 38 in both the male and the female. The male karyotype comprised 10 pairs of large acrocentric chromosomes (1st–10th), eight pairs of small acrocentric chromosomes (11th–18th), and one pair of microchromosomes (19th) (Fig. 1a). By contrast, the number of large acrocentric chromosomes was 19, and one additional microchromosome was found in the female (Fig. 1b). The Hoechst-stained chromosome banding pattern indicated that the fifth largest chromosome was the Z sex chromosome and that the additional microchromosome was the W sex chromosome. Cytogenetic map of *L. agilis* and chromosome homology between *L. agilis* and chicken

The 18S–28S rRNA genes were localized to the subtelomeric region of chromosome 6 of *L. agilis* (Fig. 2a, c), and hybridization signals of the 5S rRNA genes were found in the terminal region of chromosome 7 of *L. agilis* (Fig. 2d–g). Analysis of 86 functional genes by FISH mapping with cDNA clones enabled us to construct a cytogenetic map of *L. agilis* (Figs. 3, 4, and 5). This is the first cytogenetic map for lacertid lizards. More than 30 metaphase spreads were observed for each gene, with hybridization efficiencies that ranged from approximately 20 to 80 %. Chromosome homology between *L. agilis* and chicken was examined using the chicken genome database (<http://www.ncbi.nlm.nih.gov/genome/guide/chicken/>). Seven genes that were mapped to *L. agilis* (LAG) chromosome 1 were localized to chicken (*Gallus gallus*, GGA) chromosomes 5, 7, and 19 (Figs. 3 and 5, Table 1). Seven genes mapped on LAG2 were localized to GGA12, 13, 16, and 18. Three genes on LAG3 were located on GGA3 and 13. LAG4 corresponded to GGA1q, and LAG5 (the Z sex chromosome) had homology with GGA6 and GGA9 (Figs. 4, 5). Six genes on LAG6 were localized to GGA17, 21, and 23, and six genes on

LAG7 were localized to GGA8, 20, and 26. LAG8 was homologous to GGA2q; however, *HDAC3* on LAG8 was located on GGA13. LAG9 showed homology with GGA1p and LAG10 with GGA4q. The homologous segments of 16 chicken genes linked to microchromosomes were found in small acrocentric chromosomes (LAG11–18) and a microchromosome (LAG19) (Table 1).

Discussion

Homology of the *L. agilis* Z chromosome with chromosomes of other Toxicofera species

The karyotype of female *L. agilis* ($2n=38$) was found to consist of nine pairs of large acrocentric chromosomes, eight pairs of small acrocentric chromosomes, one pair of microchromosomes, a large acrocentric Z chromosome, and a micro-W chromosome. This result is identical to those of previous reports (De Smet 1981; Odierna et al. 1993). The *L. agilis* Z sex chromosome was identified as the fifth largest acrocentric chromosome. Comparative gene mapping also revealed that the *L. agilis* Z chromosome has homology with chicken chromosomes 6 and 9 (GGA6 and GGA9) (Fig. 5). The fusion of GGA6 and GGA9 is also found in *A. carolinensis* chromosome 3 (Alföldi et al. 2011). In addition, the *L. agilis* Z chromosome was shown to be homologous to a single pair of autosomes in three reptilian species: chromosome 3p in *L. reevesii rubritaeniata* (LRE3p), chromosome 5 in *E. quadrivirgata* (EQU5), and chromosome 6 in *V. salvator macromaculatus* (VSA6) (Figs. 5, 6), which indicates that this fusion occurred at least in the common ancestor of Toxicofera and Lacertoidea (Episquamata) (Pyron et al. 2013). The *L. agilis* Z chromosome showed no homology with either the Z chromosome of *G. hokouensis* (Gekkota), which is homologous to GGAZ (Kawai et al. 2009), or the X chromosome of *A. carolinensis* (Iguania), which is homologous to GGA15 (Alföldi et al. 2011). Moreover, the Z chromosome of *Pogona vitticeps* (Iguania) has homology with GGA23, and the Z chromosome of snakes is homologous to GGA2 and 27 (Matsubara et al. 2006, 2012; Ezaz et al. 2013). These results suggest that the sex chromosomes of these squamate reptiles differentiated independently in each lineage within the same order from different autosomal pairs of the common ancestor.

In Lacertidae, some species have homomorphic sex chromosomes, whereas many other lacertid lizards show morphologically differentiated ZW-type sex chromosomes (Olmo and Signorino 2005). For instance, large-sized W sex chromosomes are found in *Takydromus sexlineatus* and *Gallotia galloti*, whereas *Acanthodactylus erythrurus*, *Meroles cuneirostris*, *Lacerta monticola*, and *Lacerta viridis* have intermediate-sized W chromosomes, and *Lacerta dugesii* and *Eremias velox* have micro-W chromosomes (Olmo et al. 1987; Pokorná et al. 2011). These findings indicate that the extent of W chromosome differentiation varies even within the same family. *L. agilis* was also shown to have a micro-W chromosome in which telomeric TTAGGG repeats were amplified after extensive differentiation of the W chromosome (Matsubara et al., unpublished data). This suggests that, of the sex chromosomes that have been characterized in lacertid lizards, the micro-W chromosome of *L. agilis* shows the highest level of differentiation. This mixture of homomorphic and heteromorphic sex chromosomes in lacertid lizards is common in vertebrates; for example, similar patterns are also observed in *Anolis* and *Sceloporus* lizards, in which morphologically indistinguishable homomorphic sex chromosomes and male heterogametic XY and XXY sex chromosomes coexist within the same genus (Leaché and Sites 2009; Gamble et al. 2013).

The process of karyotype evolution in the lineage of Lacertidae

The cytogenetic map comparing *L. agilis* with the chicken and three squamate reptiles revealed that nine chicken macrochromosomes and/or macrochromosome segments (GGA1p, 1q, 2q, 3, 4q, 5, 6, 7, and 8) are highly conserved in eight macrochromosomes of *L. agilis* [LAG1, 3, 4, 5(Z), 7, 8, 9, and 10] as well as *E. quadrivirgata* (EQU), *V. salvator macromaculatus* (VSA), and *L. reevesii rubritaeniata* (LRE) macrochromosomes (Matsubara et al. 2006, 2012; Srikuhnath et al. 2009b, 2013; Uno et al. 2012) (Figs. 5, 6). These conserved syntenies with chicken chromosomes were also found in *A. carolinensis* (ACA) macrochromosomes (Alföldi et al. 2011), although half of the gene markers mapped in this study have not been localized in the *A. carolinensis* genome. However, the genes mapped on LRE2p, LRE6, EQU2p, EQUZ, VSA1p, VSA4, ACA2, and ACA6 were all localized to small acrocentric chromosomes of *L. agilis* (LAG11–18), which indicates that rearrangement patterns of these segments differ between Toxicofera and Lacertoidea (Table 1). The homologous segments of 39 chicken microchromosome-linked genes were found in LAG1, 2, 3, Z(5), 6, 7, and 8, small acrocentric chromosomes (LAG11–

18), and a microchromosome (LAG19) (Fig. 5, Table 1). The fusion of GGA17, GGA21, and GGA23 was found in LAG6; by contrast, these three homologous segments were located on microchromosomes of *E. quadrivirgata* and *V. salvator macromaculatus*, which suggests that the fusion of these three chicken microchromosomes might have only occurred in *L. agilis* (Table 1).

The 18S–28S rRNA genes were localized to the subtelomeric region of chromosome 6 in *L. agilis*. Chromosomal locations of nucleolar organizer region (NOR) and 18S–28S rRNA genes have been reported in several lacertid species and are categorized into three types: terminal region on the long arm of a large acrocentric chromosome pair, terminal region on the long arm of a small acrocentric chromosome pair, and microchromosome (Odierna et al. 1987, 1995; Olmo et al. 1991; Olmo and Signorino 2005). In Aves, the major rRNA genes are supposed to have been located on a single pair of microchromosomes in the ancestral avian karyotype (Nishida-Umehara et al. 2007). The chromosomal location of the major rRNA genes in the ancestral karyotype of Toxicofera and Lacertoidea has still not been defined; however, the present results strongly support the assertion that the disappearance of microchromosomes in lacertid lizards resulted from repeated fusions of microchromosomes that existed in the ancestral karyotype. The microchromosome-linked genes of *V. salvator macromaculatus* and *L. reevesii rubritaeniata*, *TRIM37* and *AMH* (GGA19-linked gene homologs) and *EEF2* (GGA28-linked gene homologs), were shown to be localized to the distal ends of the short and long arms of EQU1, respectively (Matsubara et al. 2006, 2012; Srikulnath et al. 2009b, 2013). However, in *L. agilis*, *TRIM37* and *AMH* were shown to be localized to the interstitial region of LAG1 that is homologous to EQU 1 q, and *EEF 2* was located on one pair of microchromosomes (LAG19) (Fig. 6). These results suggest that this tandem fusion of microchromosomes with macrochromosomes occurred in *E. quadrivirgata* independently from the lineage of *L. agilis*.

Cytogenetic maps that compare *L. agilis* with each of three Toxicofera species enabled us to apply the most parsimonious explanation of chromosomal rearrangements to deduce the course of karyotype evolution in lacertid species (Fig. 6). LAG3 was shown to be homologous to LRE1p, EQU1p, and VSA2p; however, the gene order from the centromere differed between *L. agilis* and these three species. This result suggests that two paracentric inversions occurred in the proto-LAG3 after centric fission from the proto bi-armed chromosome, which seems to be the ancestral type of LRE1, EQU1, and VSA2 (Fig. 7a). Alternative possibilities are that two inversions occurred sequentially in LAG3, and this chromosome then fused with LAG1 (Fig. 7a), or that two inversions occurred sequentially in the p arm of the proto bi-armed chromosome after centric fusion of LAG3 and LAG1 or before centric fission of the proto bi-armed chromosome (Fig. 7b). According to the most parsimonious explanation of chromosomal rearrangements in the lineages of Toxicofera and Lacertoidea, the fission event to form LAG1 and LAG3 from the proto bi-armed chromosome is most likely. LAG4 was shown to correspond to LRE3q and LAGZ (5) to LRE3p. LAG7 was homologous to LRE4q and EQU3q and LAG8 to LRE4p and EQU3p. LAG9 was homologous to LRE5q and LAG10 to LRE5p. These six acrocentric chromosomes in *L. agilis* might each have been derived from centric fission of an ancestral bi-armed chromosome, or alternatively, the bi-armed chromosomes may each have resulted from centric fusion of two acrocentric chromosomes (Fig. 7c–e). However, centric fusion between LAG4 and LAGZ (5) and centric fission of LRE4 or EQU3 and of LRE5 are most likely because LAG4 and LAGZ (5), LRE4 or EQU3, and LRE5 are considered to be the prototypes in the lineages of Toxicofera and Lacertoidea according to the most parsimonious explanation of chromosomal rearrangements.

Comparison of the cytogenetic maps of four squamate species (*L. agilis*, *E. quadrivirgata*, *V. salvator macromaculatus*, *L. reevesii rubritaeniata*, and *A. carolinensis*) in this study revealed the origin of the Z and W sex chromosomes of *L. agilis* and the karyotype reorganization that occurred between *L. agilis* and other Toxicofera species. However, comparative gene mapping for more closely related species in Lacertoidea, such as Gymnophthalmidae and Amphisbaenia, and also distantly related species in Gekkota, which lack microchromosomes, is necessary in order to delineate karyotype evolution in Squamata more precisely. Greater precision in the identification of conserved chromosomal segments in sauropsids will provide insight into the phylogenetic hierarchy of genome evolution in amniotes.

Table 1 List of 86 cDNA clones mapped to sand lizard (*Lacerta agilis*) chromosomes and their chromosomal locations in the water monitor lizard (*Varanus salvator macromaculatus*), the butterfly lizard (*Leiolepis reevesii rubritaeniata*), the Japanese four-striped rat snake (*Elaphe quadrivirgata*), the green anole (*Anolis carolinensis*), and chicken (*Gallus gallus*)

Gene symbol	Sequenced length of cDNA fragment (bp)	Chromosomal location						Accession number	
		<i>L. agilis</i>	<i>V. salvator macromaculatus</i>	<i>L. reevesii rubritaeniata</i>	<i>E. quadrivirgata</i>	<i>A. carolinensis</i>	<i>G. gallus</i>		
<i>ACVRI</i> ^a	845	1	2q	–	–	–	7	AB794073	
<i>CACNB4</i> ^b	882	1	2q	–	1q12.2–q13.1	1q	–	7	AB490346
<i>TRIM37</i> ^{b,c}	631, 577	1	Micro	–	Micro	–	–	19	AB490382, AB490383
<i>AMH</i> ^{d,e}	712, 709	1	Micro	–	–	–	–	19	AB794387, AB794388
<i>WT1</i> ^b	542	1	2q	–	1q21.1–q22.1	1q	1	5	AB490347
<i>DYNCH1</i> ^b	997	1	2q	–	1q32.1–q32.3	1q	–	5	AB490348
<i>CYP2C21-like</i> ^a	1,331	1	2q	–	–	–	–	–	AB794068
<i>KRT8</i> ^a	835	2	Micro	–	–	–	–	–	AB794081
<i>SOX9</i> ^{b,c}	603, 717	2	1q	–	2q11.2–q11.4	2q	–	18	AB490350, AB490351
<i>TOBI</i> ^a	950	2	1q	–	–	–	2	18	AB794087
<i>RUFY1</i> ^b	545	2	1q	–	2q12.2–q21.1	2q	2	13	AB490352
<i>TKT</i> ^b	943	2	1q	–	2q11.1	2q	2	12	AB490349
<i>ALAS1</i> ^a	1,060	2	1q	–	–	–	2	12	AB794074
<i>BRD2</i> ^b	691	2	1q	–	2q22.2	–	–	16	AB480353
<i>XABI</i> ^b	489	3	2p	–	1p22.4	1p	–	3	AB490344
<i>FBXW1</i> ^e	926	3	2p	–	–	1p	1	13	AB792691
<i>ESR1</i> ^b	951	3	2p	–	1p21.2	1p	–	3	AB490345
<i>TPT1</i> ^b	438	4	5q	–	3p11.1–q11	4p	–	1q	AB490359
<i>IPO5</i> ^{a,c}	703, 492	4	5q	–	–	–	3	1q	AB793729, AB793730
<i>EIF2S3</i> ^b	733	4	5q	–	3q12.3–q21.1	4p	3	1q	AB490361
<i>OCA2</i> ^b	782	4	5q	–	3q12.1–q12.2	–	3	1q	AB490360
<i>ELMOD1</i> ^b	682	4	5q	–	3q22.1–q22.3	4q	–	1q	AB490362
<i>ADAM12</i> ^a	933	5 (Z)	6q	–	–	–	3	6	AB794067
<i>PSAP</i> ^b	1,325	5 (Z)	6q	–	3p11.2–p12.2	5q	–	6	AB490358
<i>BTRC</i> ^b	889	5 (Z)	6q	–	3p21.1–p21.2	–	–	6	AB490357
<i>SH3PXD2A</i> ^b	1,210	5 (Z)	6q	–	3p22.1	5q	3	6	AB490356
<i>SLIT1</i> ^a	995	5 (Z)	6q	–	–	–	–	6	AB794071
<i>EPHA4</i> ^a	888	5 (Z)	6q	–	–	–	3	9	AB794079
<i>TLOC1</i> ^b	782	5 (Z)	6q	–	3p22.3	5q	3	9	AB490355
<i>SKIL</i> ^a	1,686	5 (Z)	6q	–	–	–	3	9	AB794070
<i>NCL</i> ^a	1,780	5 (Z)	6q	–	–	–	–	9	AB794069

Table 1 (continued)

Gene symbol	Sequenced length of cDNA fragment (bp)	Chromosomal location						Accession number
		<i>L. agilis</i>	<i>V. salvator macromaculatus</i>	<i>L. reevesii rubritaeniata</i>	<i>E. quadrivirgata</i>	<i>A. carolinensis</i>	<i>G. gallus</i>	
<i>ENO1</i> ^a	917	6	Micro	–	Micro	–	21	AB794078
<i>TMEM57</i> ^a	800	6	Micro	–	–	–	23	AB794086
<i>RNF19B</i> ^a	942	6	Micro	–	–	–	23	AB793732
<i>DNM1</i> ^a	1,014	6	Micro	–	Micro	–	17	AB794076
<i>PPP2R1A</i> ^a	1,169	6	Micro	–	–	–	–	AB793731
<i>GRIN1</i> ^a	893	6	Micro	–	Micro	–	17	AB794080
<i>RPE65</i> ^a	1,130	7	8p	–	–	–	8	AB793733
<i>ZNF326</i> ^b	892	7	8p	4q12.1–q12.3	3q	4	8	AB490366
<i>CNTN2</i> ^a	922	7	8q	–	–	4	26	AB793728
<i>USP49</i> ^a	1,210	7	8q	–	–	4	26	AB794088
<i>RBM12</i> ^b	943	7	8q	4q21.2–q22.1	3q	4	20	AB490367
<i>RPN2</i> ^a	1,229	7	8q	–	–	–	20	AB794084
<i>HDAC3</i> ^b	929	8	7p	4p11.1–p11.2	3p	4	13	AB490365
<i>SSI8</i> ^{b,c}	614, 508	8	7q	4p12.2–p21.2	3p	4	2q	AB490364, AB490397
<i>ENPP2</i> ^b	961	8	7q	4p22.2–p22.4	3p	–	2q	AB490363
<i>DYRK2</i> ^b	1,086	9	3p	5q12–q21.2	–	–	1p	AB490373
<i>RANGAP1</i> ^b	1,024	9	3p	5q21.2–q22.1	6q	5	1p	AB490374
<i>TTC26</i> ^b	772	9	3p	5q21.3–q22.3	6q	–	1p	AB490375
<i>SOX5</i> ^{b,c}	851, 705	9	3p	5q22.1–q22.4	–	5	1p	AB490376, AB490377
<i>UCHL1</i> ^b	595	10	3p	5p11.1–p12.1	6p	5	4q	AB490372
<i>EXOC1</i> ^b	1,177	10	3q	5p11.2–p12.2	7p	5	4q	AB490371
<i>ACSL1</i> ^b	748	10	3q	5p12.1–p12.2	7q	5	4q	AB490370
<i>DCLK2</i> ^b	688	10	3q	5p12.1–p21	–	5	4q	AB490369
<i>SMAD1</i> ^a	944	10	3q	–	–	5	4q	AB794085
<i>RAP1GDS1</i> ^b	991	10	3q	5p21–p22.2	7q	–	4q	AB490368
<i>ATP5A1</i> ^f	987	11–18	1p	2p23.1–p23.3	2p	1	Zp	AB480291, AB480292
<i>GHR</i> ^b	771	11–18	1p	2p22–p23.3	2p	2	Zp	AB480290
<i>CHD1</i> ^b	961	11–18	1p	2p21	2p	2	Zq	AB480289
<i>DMRT1</i> ^b	628	11–18	1p	2p12–p21	2p	2	Zp	AB480288
<i>RPS6</i> ^b	521	11–18	1p	2p11.3–p12	2p	2	Zp	AB480287
<i>ACO1/IREBP</i> ^f	1,122	11–18	1p	2p11.2–p11.4	2p	–	Zq	AB480285, AB480286
<i>MYST2</i> ^b	1,261	11–18	4p	6p21.1–p22.2	Zq	6	27	AB490378

Table 1 (continued)

Gene symbol	Sequenced length of cDNA fragment (bp)	Chromosomal location						Accession number
		<i>L. agilis</i>	<i>V. salvator macromaculatus</i>	<i>L. reevesii rubritaeniata</i>	<i>E. quadrivirgata</i>	<i>A. carolinensis</i>	<i>G. gallus</i>	
<i>STAT3</i> ^a	1,654	11–18	4p	–	–	6	27	AB793734
<i>TOP2A</i> ^{a,c}	882, 477	11–18	4p	–	–	6	27	AB793735, AB793736
<i>TOP2B</i> ^a	1,639	11–18	4q	–	–	–	2p	AB793737
<i>CTNNA1</i> ^b	1,201	11–18	4q	6q11	Zp	6	2p	AB490379
<i>WAC</i> ^b	1,122	11–18	4q	6q21–q23	Zp	6	2p	AB490381
<i>GAD2</i> ^b	672	11–18	4q	6q21–q23	Zp	6	2p	AB490380
<i>CUL4B</i> ^b	723	11–18	Micro	Micro	–	–	4p	AB490387
<i>ATRX</i> ^b	804	11–18	Micro	Micro	Micro	–	4p	AB490386
<i>AR</i> ^b	941	11–18	Micro	Micro	Micro	–	4p	AB490385
<i>CHD2</i> ^{b,c}	654, 692	11–18	Micro	Micro	–	–	10	AB490388, AB490389
<i>POLG</i> ^a	1,565	11–18	Micro	–	Micro	–	10	AB794083
<i>BRD7</i> ^b	784	11–18	Micro	Micro	Micro	–	11	AB490390
<i>EEF2K</i> ^a	970	11–18	Micro	–	Micro	–	14	AB794077
<i>UBN1</i> ^a	1,153	11–18	Micro	–	–	–	14	AB794072
<i>PDXDC1</i> ^a	1,619	11–18	Micro	–	–	–	14	AB794082
<i>NF2</i> ^b	940	11–18	Micro	Micro	–	–	15	AB490393
<i>SF3A1</i> ^b	937	11–18	Micro	Micro	–	–	15	AB490394
<i>ATP2A2</i> ^b	972	11–18	Micro	Micro	Micro	Micro	15	AB490391
<i>SBNO1</i> ^b	1,345	11–18	Micro	Micro	–	Micro	15	AB490392
<i>HSPA8</i> ^b	906	11–18	Micro	Micro	Micro	Micro	24	AB490395
<i>ARNT</i> ^a	1,034	11–18	Micro	–	–	–	25	AB794075
<i>ACTN4</i> ^b	1,069	11–18	Micro	Micro	–	–	–	AB490396
<i>EEF2</i> ^b	975	19	Micro	Micro	1q	1	28	AB490384

– No data

^a The cDNA fragments were obtained from *L. agilis* in Srikulnath et al. (unpublished data)

^b The cDNA fragments were obtained from of *L. reevesii rubritaeniata* in Srikulnath et al. (2009a, b)

^c Nucleotide sequences of two accession numbers were determined separately by forward and reverse primers in one clone

^d The cDNA fragments were obtained from of *E. quadrivirgata* in Matsubara et al. (unpublished data)

^e The cDNA fragments were obtained from of *G. hokouensis* in Srikulnath et al. (unpublished data)

^f Nucleotide sequences of cDNA fragments of *L. reevesii rubritaeniata* were taken from Srikulnath et al. (2009b). For mapping of *ATP5A1*, and *ACO1/IREBP*, two different fragments of the gene were simultaneously hybridized to chromosomes

Fig. 1 Hoechst-stained karyotypes of *L. agilis*: a male, (b) female. Scale bars represent 10 μ m

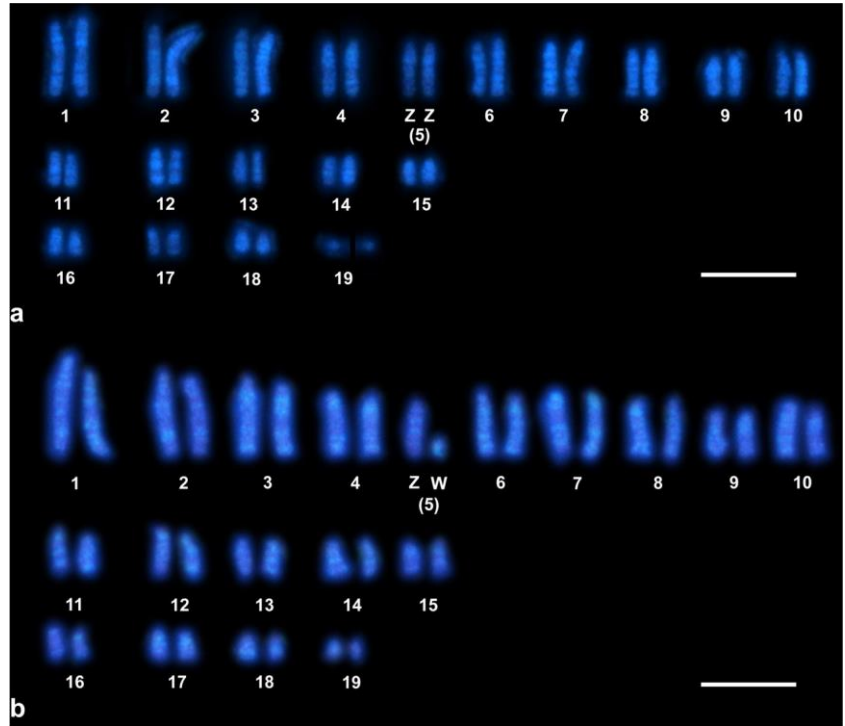

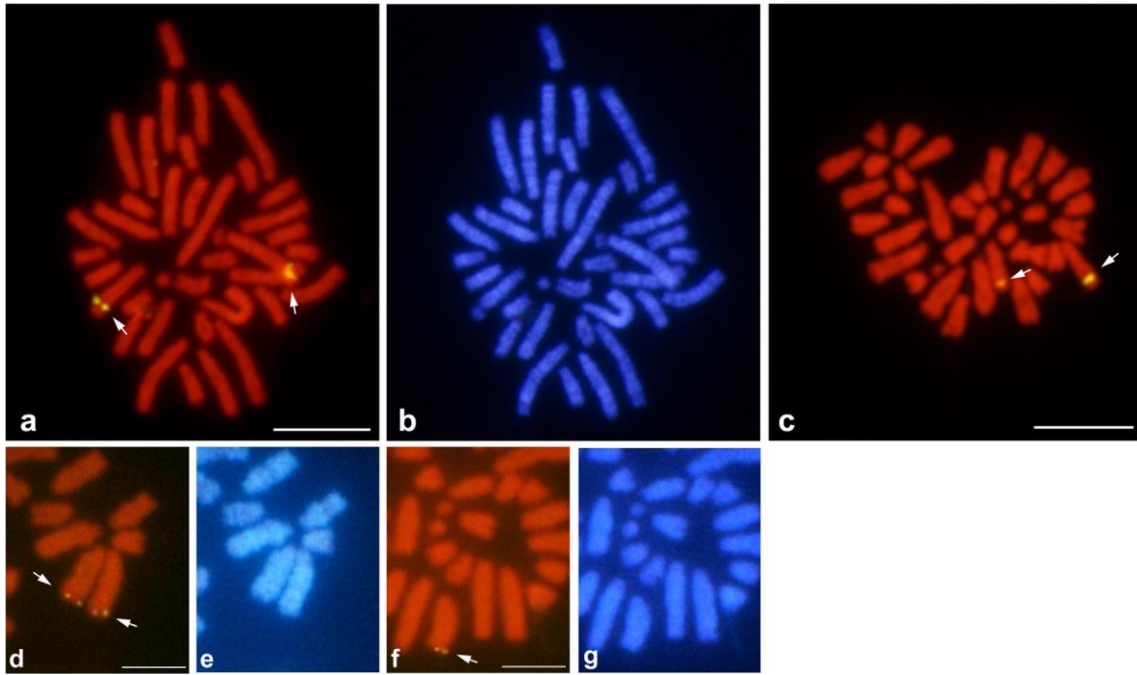

Fig. 2 Chromosomal locations of the 18S–28S and 5S rRNA genes in *L. agilis*: a, b, d, e male, c, f, g female. a, c, d, f Hybridization patterns of the 18S–28S genes (a, c) and the 5S rRNA genes (d, f). b, e, g Hoechst-stained patterns of the same metaphase spreads are shown in (a, d, f), respectively. *Arrows* indicate the hybridization signals of the 18S–28S and 5S rRNA genes. *Scale bars* represent 10 μ m

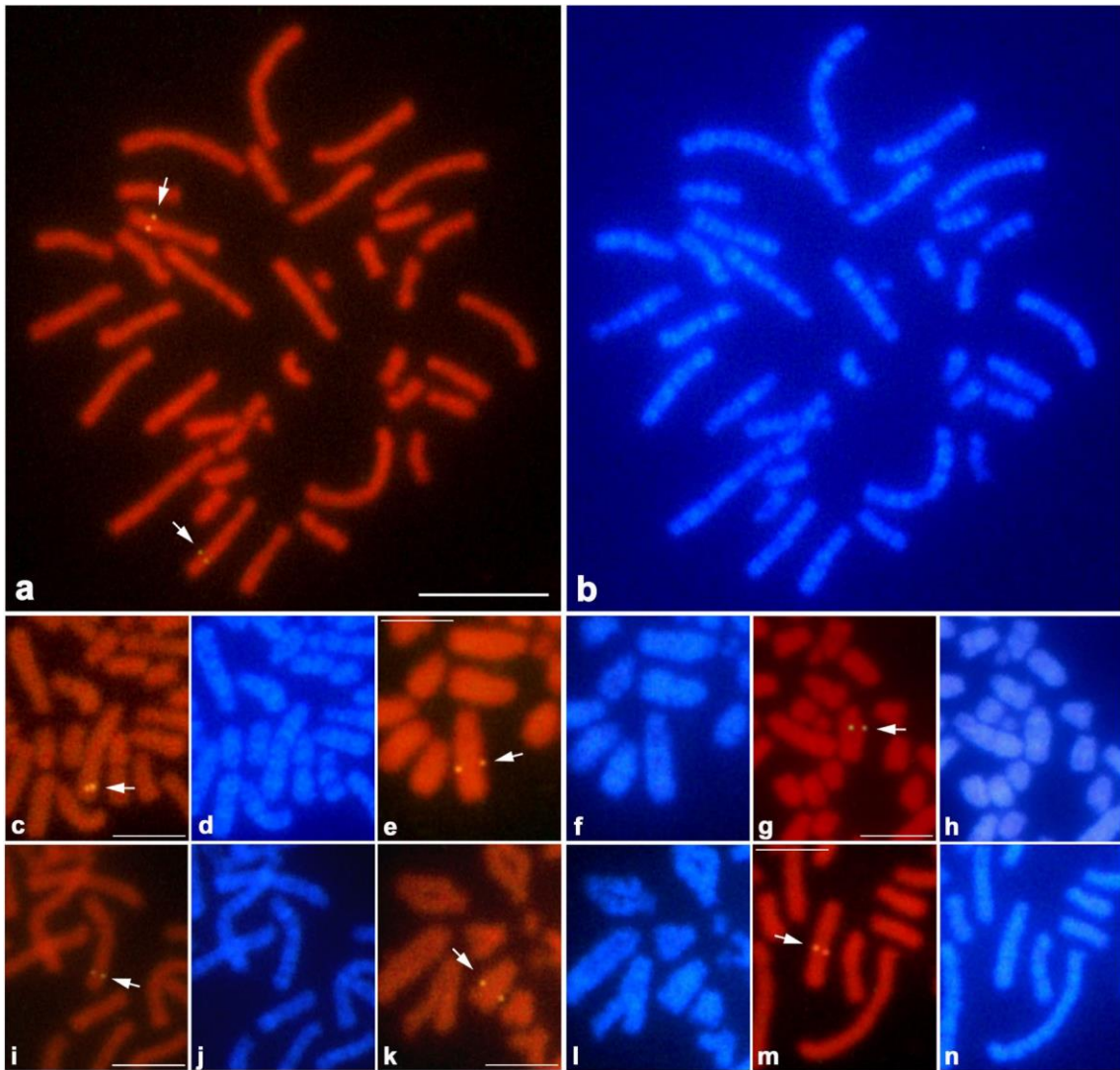
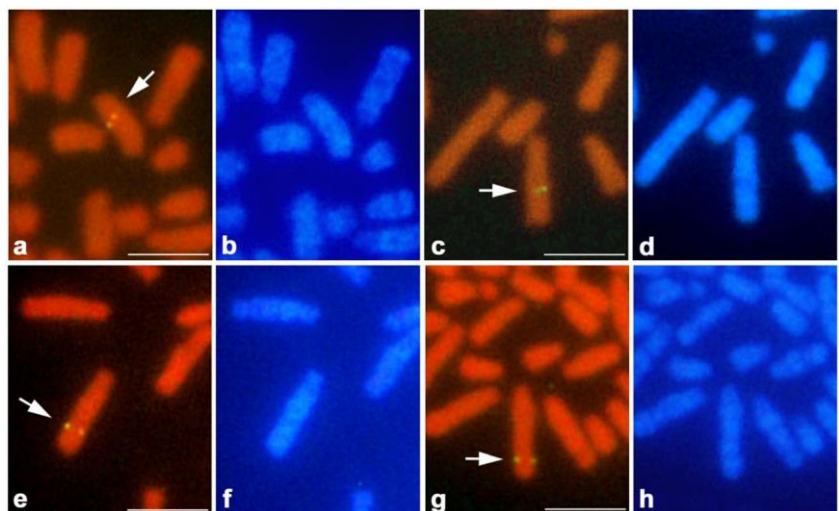

Fig. 3 Chromosomal locations of cDNA fragments of functional genes in male *L. agilis*. The *DNM1* gene was localized to chromosome 6 (a), *CYP2C21-like* to chromosome 1 (c), *ALAS1* to chromosome 2 (e), *ZNF326* to chromosome 7 (g), *ENPP2* to chromosome 8 (i), *TTC26* to chromosome 9 (k), and *DCLK2* to chromosome 10 (m). b, d, f, h, j, l, n Hoechst-stained patterns of the same metaphase spreads are shown in (a, c, e, g, i, k, m), respectively. Arrows indicate the hybridization signals. Scale bars represent 10 μm in (a) and 5 μm in (c–n)

Fig. 4 Chromosomal locations of cDNA fragments of chromosome 5 (Z)-linked genes in *L. agilis*. The *PSAP* (a), *SH3PXD2A* (c), *EPHA4* (e), and *TLOC1* (g) genes were localized to the Z sex chromosome. b, d, f, h Hoechst-stained patterns of the PI-stained metaphase spreads are shown in (a, c, e, g), respectively. Arrows indicate the hybridization signals. Scale bars represent 5 μm



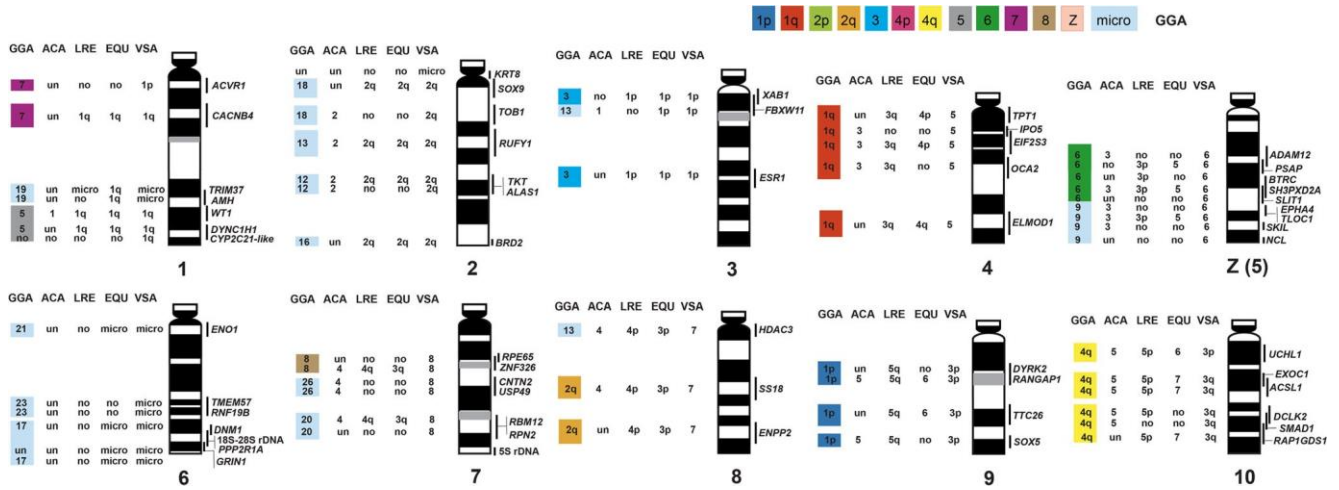

Fig. 5 Cytogenetic maps comparing *L. agilis* with the chicken, the green anole, butterfly lizard, Japanese four-striped rat snake, and water monitor lizard. All maps were constructed using 56 functional genes and the 18S–28S and 5S rRNA genes. The ideogram of *L. agilis* chromosomes was constructed according to Hoechst-stained band patterns. Locations of the genes on *L. agilis* chromosomes are shown to the right of the chromosomes. The numbers of chromosome of chicken (*Gallus gallus*, GGA), the green anole (*Anolis carolinensis*, ACA), butterfly lizard (*Leiolepis reevesii rubritaeniata*, LRE), Japanese four-striped rat snake (*Elaphe quadrivirgata*, EQU), and water monitor lizard (*Varanus salvator macromaculatus*, VSA) that show homologies with *L. agilis* chromosomes are shown to the left. Whereas “no” indicates no data on chromosome homology, “un” indicates a gene whose chromosomal location remains undetermined. The chromosomal locations of genes for *L. reevesii rubritaeniata* were taken from Srikulnath et al. (2009b), those for *A. carolinensis* from Alföldi et al. (2011), those for *E. quadrivirgata* from Matsubara et al. (2006, 2012), and those for *V. salvator macromaculatus* from Srikulnath et al. (2013)

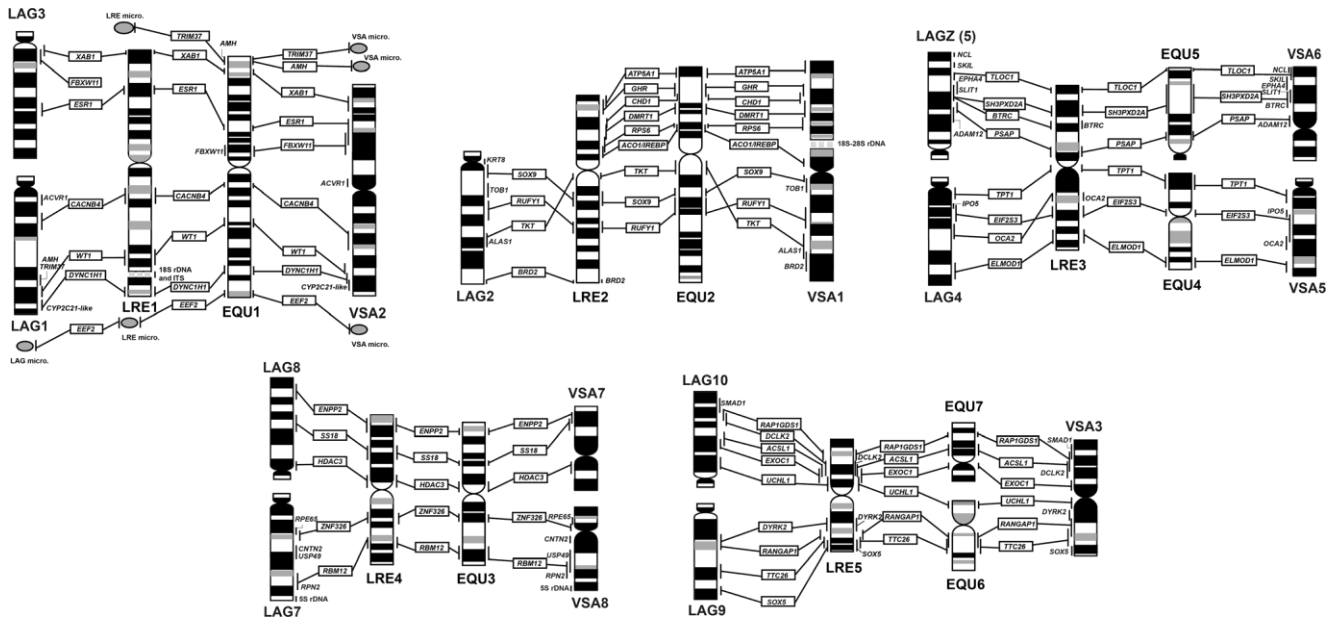

Fig. 6 Comparative cytogenetic maps of macrochromosomes among *L. agilis*, *V. salvator macromaculatus*, *L. reevesii rubritaeniata*, and *E. quadrivirgata* were constructed with 58 functional genes. The chromosome map of *L. reevesii rubritaeniata* (LRE) was taken from Srikulnath et al. (2009b). The ideogram of *E. quadrivirgata* (EQU) macrochromosomes was taken from Matsuda et al. (2005) and chromosomal locations of the genes in *E. quadrivirgata* from Matsubara et al. (2006, 2012). The chromosome map of *V. salvator macromaculatus* was taken from Srikulnath et al. (2013). *L. agilis* chromosome (LAG)8, LAG10, LAG5(Z), VSA3, VSA6, VSA7, EQU5, and EQU7 are inverted to facilitate comparison.

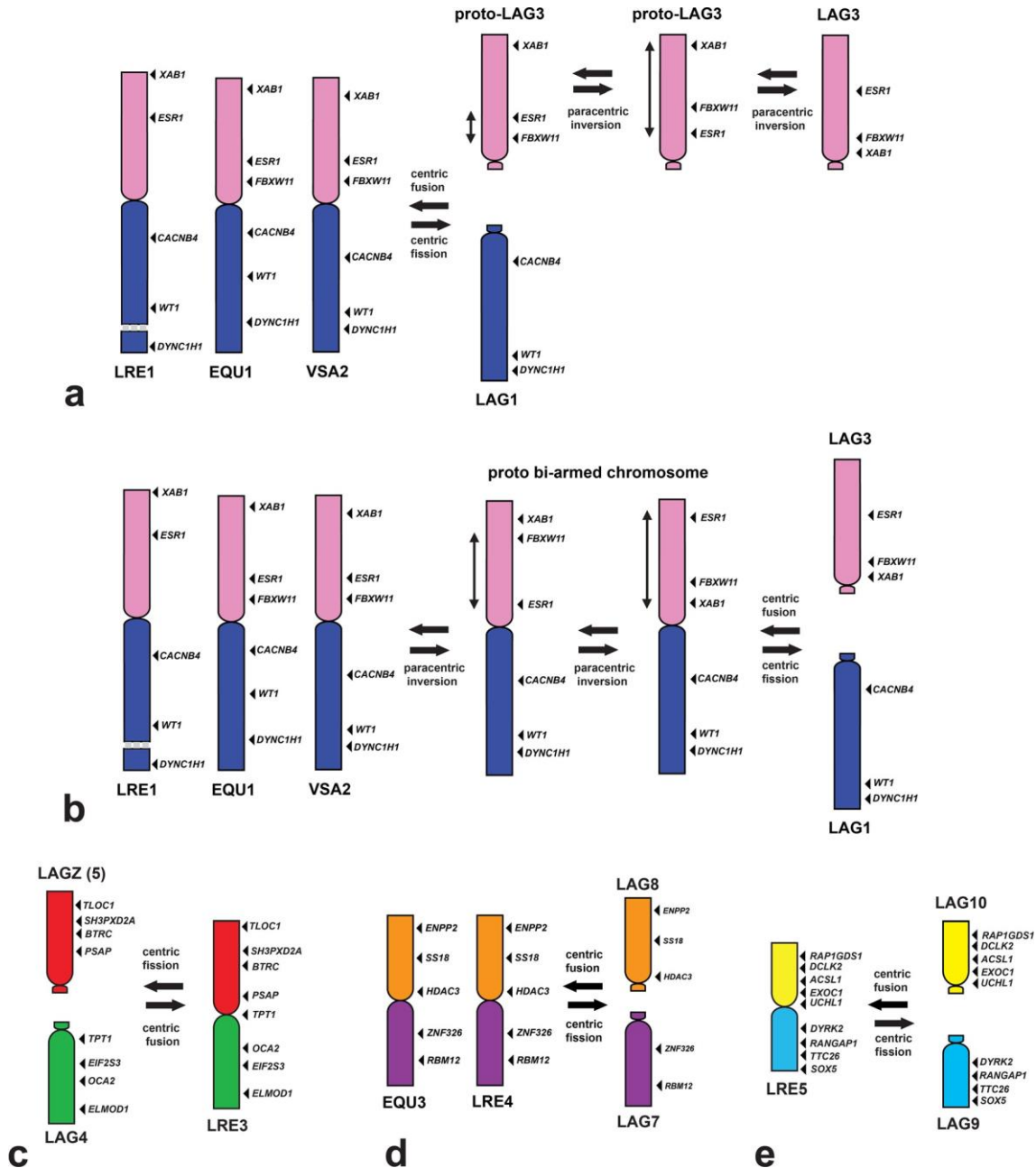

Fig. 7 Schematic representation of the process of chromosomal rearrangements that occurred in *L. agilis* chromosomes 1, 3, 4, 5(Z), 7, 8, 9, and 10 [LAG1, LAG3, LAG4, LAGZ(5), LAG7, LAG8, LAG9, and LAG10], *V. salvator macromaculatus* chromosome 2 (VSA2), *L. reevesii rubritaeniata* chromosomes 1, 3, 4, and 5 (LRE1, LRE3, LRE4, and LRE5), and *E. quadrivirgata* chromosomes 1 and 3 (EQU1 and EQU3). LAG3, LAGZ, LAG8, and LAG10 are inverted to facilitate comparison. Chromosomal locations of the genes are shown to the right of the chromosomes by arrowheads. Homologous chromosomes and/or chromosome segments are shown in the same color. The diagram schematically summarizes the occurrences of LRE1, EQU1, VSA2, LAG1, and LAG3 (a, b); LRE3, LAG4, and LAGZ (c); LRE4, EQU3, LAG7, and LAG8 (d); and LRE5, LAG9, and LAG10 (e). Arrows indicate the directions of chromosomal rearrangement. Bidirectional arrows indicate the regions where paracentric inversions may have occurred

Acknowledgments This work was financially supported by Grants-in-Aid for Scientific Research on Innovative Areas (No. 23113004) and Scientific Research (B) (No. 22370081) from the Ministry of Education, Culture, Sports, Science and Technology, Japan. Mats Olsson thanks the Australian Research Council for financial support.

References

- Alföldi J, Di Palma F, Grabherr M et al (2011) The genome of the green anole lizard and a comparative analysis with birds and mammals. *Nature* 477:587–591. doi:10.1038/nature10390
- Ciofi C, Swingland IR (1997) Environmental sex determination in reptiles. *Appl Anim Behav Sci* 51:251–265
- Cree A, Thompson MB, Daugherty CH (1995) Tuatara sex determination. *Nature* 375:543. doi:10.1038/375543a0
- De Smet WHO (1981) Description of the orcein stained karyotypes of 27 lizard species (Lacertilia, Reptilia) belonging to the families Teiidae, Scincidae, Lacertidae, Cordylidae and Varanidae (Autarchoglossa). *Acta Zool Pathol Antverpiensia* 76:73–118
- Ezaz T, Sarre SD, O'Meally D, Marshall Graves JA, Georges A (2010) Sex chromosome evolution in lizards: independent origins and rapid transitions. *Cytogenet Genome Res* 127:249–260. doi:10.1159/000300507
- Ezaz T, Azad B, O'Meally D et al (2013) Sequence and gene content of a large fragment of a lizard sex chromosome and evaluation of candidate sex differentiating gene R-spondin 1. *BMC Genomics* 14: 899. doi:10.1186/1471-2164-14-899
- Gamble T, Geneva AJ, Glor RE, Zarkower D (2013) *Anolis* sex chromosomes are derived from a single ancestral pair. *Evolution*. doi:10.1111/evo.12328
- Head G, May RM, Pendleton L (1987) Environmental determination of sex in the reptiles. *Nature* 329:198–199. doi:10.1038/329198a0
- International Chicken Genome Sequencing Consortium (ICGSC) (2004) Sequence and comparative analysis of the chicken genome provide unique perspectives on vertebrate evolution. *Nature* 432:695–716. doi:10.1038/nature03154
- Kawagoshi T, Uno Y, Matsubara K, Matsuda Y, Nishida C (2009) The ZW micro-sex chromosomes of the Chinese soft-shelled turtle (*Pelodiscus sinensis*, Trionychidae, Testudines) have the same origin as chicken chromosome 15. *Cytogenet Genome Res* 125:125–131. doi:10.1159/000227837
- Kawagoshi T, Nishida C, Matsuda Y (2012) The origin and differentiation process of X and Y chromosomes of the black marsh turtle (*Siebenrockiella crassicolis*, Geoemydidae, Testudines). *Chromosome Res* 20:95–110. doi:10.1007/s10577-011-9267-7
- Kawai A, Ishijima J, Nishida C, Kosaka A, Ota H, Kohno S, Matsuda Y (2009) The ZW sex chromosomes of *Gekko hokouensis* (Gekkonidae, Squamata) represent highly conserved homology with those of avian species. *Chromosoma* 118:43–51. doi:10.1007/s00412-008-0176-2
- Lang JW, Andrews HV (1994) Temperature-dependent sex determination in crocodylians. *J Exp Zool* 270:28–44. doi:10.1002/jez.1402700105
- Leaché AD, Sites JW Jr (2009) Chromosome evolution and diversification in north American spiny lizards (Genus *Sceloporus*). *Cytogenet Genome Res* 127:166–181. doi:10.1159/000293285
- Matsubara K, Tarui H, Toriba M et al (2006) Evidence for different origin of sex chromosomes in snakes, birds, and mammals and step-wise differentiation of snake sex chromosomes. *Proc Natl Acad Sci U S A* 103:18190–18195. doi:10.1073/pnas.0605274103
- Matsubara K, Kuraku S, Tarui H et al (2012) Intra-genomic GC heterogeneity in sauropsids: evolutionary insights from cDNA mapping and GCs profiling in snake. *BMC Genomics* 13:604. doi:10.1186/1471-2164-13-604
- Matsuda Y, Chapman VM (1995) Application of fluorescence in situ hybridization in genome analysis of the mouse. *Electrophoresis* 16: 261–272
- Matsuda Y, Nishida-Umehara C, Tarui H et al (2005) Highly conserved linkage homology between birds and turtles: bird and turtle chromosomes are precise counterparts of each other. *Chromosome Res* 13:601–615. doi:10.1007/s10577-005-0986-5
- Nishida-Umehara C, Tsuda Y, Ishijima J, Ando J, Fujiwara A et al (2007) The molecular basis of chromosome orthologies and sex chromosomal differentiation in palaeognathous birds. *Chromosome Res* 15: 721–734. doi:10.1007/s10577-007-1157-7
- Odierna G, Olmo E, Cobror O (1987) Taxonomic implications of NOR-localization in lacertid lizards. *Amphibia-Reptilia* 87:373–382
- Odierna G, Kupriyanova L, Capriglione T, Olmo E (1993) Further data on sex chromosomes of Lacertidae and a hypothesis on their evolutionary trend. *Amphibia-Reptilia* 14:1–11
- Odierna G, Olmo E, Caputo V, Capriglione T, in den Bosch HAJ (1995) Karyological affinity between *Lacerta fraasii* Lehrs, 1910 and *Lacerta parva* Boulenger, 1887. *Amphibia-Reptilia* 16:293–297
- Olmo E, Signorino G (2005) Chromorep: a reptile chromosomes database. Internet references. Retrieved from: <http://chromorep.univpm.it>. 6/04/2013
- Olmo E, Odierna G, Capriglione T (1987) Evolution of sex-chromosomes in lacertid lizards. *Chromosoma* 96:33–38
- Olmo E, Odierna G, Capriglione T, Caputo V (1991) A karyological approach to the systematic of Lacertidae (Reptilia, Sauria). *Rev Esp Herpetol* 6:81–90
- Pokorná M, Kratochvíl L, Kejniovský E (2011) Microsatellite distribution on sex chromosomes at different stages of heteromorphism and heterochromatinization in two lizard species (Squamata: Eublepharidae: *Coleonyx elegans* and Lacertidae: *Eremias velox*). *BMC Genet* 12:90. doi:10.1186/1471-2156-12-90
- Pyron RA, Burbrink FT, Wiens JJ (2013) A phylogeny and revised classification of Squamata, including 4161 species of lizards and snakes. *BMC Evol Biol* 13:93. doi:10.1186/1471-2148-13-93
- Shedlock AM, Edwards SV (2009) Amniota. In: Hedges SB, Kumar S (eds) *The timetree of life*. Oxford University Press, New York, pp 375–379
- Srikulnath K, Matsubara K, Uno Y et al (2009a) Karyological characterization of the butterfly lizard (*Leiolepis reevesii rubritaeniata*, Agamidae, Squamata) by molecular cytogenetic approach. *Cytogenet Genome Res* 125:213–223. doi:10.1159/000230005
- Srikulnath K, Nishida C, Matsubara K et al (2009b) Karyotypic evolution in squamate reptiles: comparative gene mapping revealed highly conserved linkage homology between the butterfly lizard (*Leiolepis reevesii rubritaeniata*, Agamidae, Lacertilia) and the Japanese four-striped rat snake (*Elaphe quadrivirgata*, Colubridae, Serpentes). *Chromosome Res* 17:975–986. doi:10.1007/s10577-009-9101-7
- Srikulnath K, Uno Y, Nishida C, Matsuda Y (2013) Karyotype evolution in monitor lizards: cross-species chromosome mapping of cDNA reveals highly conserved synteny and gene order in the Toxicofera clade. *Chromosome Res* 21:805–819. doi:10.1007/s10577-013-9398-0
- Uetz P (2014) The TIGR reptile database. The EMBL reptile database. Retrieved from: <http://www.reptile-database.org/>
- Uno Y, Nishida C, Tarui H et al (2012) Inference of the protokaryotypes of amniotes and tetrapods and the evolutionary processes of microchromosomes from comparative gene mapping. *PLoS ONE* 7:e53027. doi:10.1371/journal.pone.0053027
- Vidal N, Hedges SB (2005) The phylogeny of squamate reptiles (lizards, snakes, and amphisbaenians) inferred from nine nuclear protein-coding genes. *C R Biol* 328:1000–1008. doi:10.1016/j.crv.2005.10.001