



The role played by perceived usability, satisfaction and consumer trust on website loyalty

Carlos Flavián*, Miguel Guinalú, Raquel Gurrea

Facultad de Ciencias Económicas y Empresariales, University of Zaragoza, Gran Vía No. 2, Zaragoza 50005, Spain

Received 9 April 2004; accepted 27 January 2005
Available online 14 March 2005

Abstract

We performed a study to determine the influence that perceived usability has on the user's loyalty to websites that they visit. The results of the empirical analysis confirmed that the trust of the user increases when the user perceived that the system was usable and that there was a consequent increase in the degree of website loyalty. In the same way, greater usability was found to have a positive influence on user satisfaction, and this also generated greater website loyalty. Finally, it was found that user trust was partially dependent on the degree of consumer website satisfaction.

© 2005 Elsevier B.V. All rights reserved.

Keywords: Usability; Satisfaction; Trust; Loyalty

1. Introduction

Due to the influence of the Internet on economic activity [95,105] traditional areas of study, such as satisfaction and loyalty, have received a new impulse as a consequence of the incorporation of businesses in the virtual medium. Similarly, other concepts, such as trust or usability, are acquiring a particular relevance due to the especially important part they play in the provision of services through the Internet. Despite the importance of these concepts there have been few studies that have analysed the relationship between them. Our study was

initiated to provide reliable and valid scales of measurement of all the variables, especially those with of usability, since it is the only one that has been subjected to the most demanding criteria. Specifically, the objective of this study was the analysis of the influence of perceived website usability on user trust and satisfaction and the incidence of these three variables on the loyalty shown by Internet users.

2. Website usability

While the website might seem cold and distant compared to a traditional establishment, it also offers new and interesting possibilities. Because of these and the relative lack of literature on the issues involved,

* Corresponding author. Tel.: +34 976762719;
fax: +34 976761767.

E-mail address: cflavian@unizar.es (C. Flavián).

there have been many research projects centred on analysis of the consumer's perceptions of these establishments [85,97], and on studying the influence of the site attributes that affect the conduct of the potential buyer [65,21,16]. Based on these studies, it seems likely that in the new environment, *perceived website usability* is a very important part of the store's image and that it can influence shopping behaviour in a similar way to those aspects of traditional establishments [68,62]. In fact, *usability* has been shown to be a key factor when the services of an organisation use the Internet. Indeed, Kim and Eom [53] concluded that usability is of critical importance in achieving the satisfaction of the user. Ranganathan and Ganapathy [86] also referred to the importance of the concept when attempting to identify the key dimensions of website quality.

According to ISO 9241,¹ IT system usability involves the effectiveness, efficiency and satisfaction with which specified users achieve specified goals in particular environments. In a website, usability reflects the *perceived ease of navigating the site* or making purchases through the Internet. For Nielsen [79], website usability involves the ease with which the user can learn to manage the system and memorise the basic functions, the efficiency of design of the site, the degree of error avoidance and the general satisfaction of the user. More recently, it has been suggested that website usability "*is a quality attribute that assesses how easy user interfaces are to use*" [78]. These definitions show the coincidence between the concept of "*ease of use*" and usability. However, e-commerce literature uses the term usability more frequently, so "*ease of use*" is no longer used in this paper. In addition we need to emphasise the difference between usability and usefulness. Some authors consider the influence of several website characteristics on the likelihood of use. For example, Swaminathan et al. [102] proposed that the greater the perceived usefulness of information of web vendors, the greater the likelihood of electronic exchange. However, such authors discuss the richness or relevance of the information, not its ease of use. Consequently, we propose that there is a clear

distinction between usefulness and usability. For example, Davis [22] developed and validated new scales for perceived usefulness and perceived ease of use, which are hypothesised to be major determinants of user acceptance.

Recently, several scales for quantifying the concept have been developed. These include

- The system usability scale (SUS) was developed in 1986 as part of the Digital Equipment Co. Ltd. introduction of usability engineering in back-office systems.
- The software usability measurement inventory scale (SUMI) was developed with the same objective as the SUMI questionnaire, but structured the concept of usability around different sub-scales.
- The scale of Lin et al. [63], which was intended to evaluate the global usability of a website.
- Shneiderman's 'Questionnaire for Usability Evaluation' [91].

In general terms, usability considers the following factors:

1. The ease of understanding the structure of a system, its functions, interface, and contents observed by the user.
2. Simplicity of use of the website in its initial stages.
3. The speed with which the users can find the item they are looking for.
4. The perceived ease of site navigation in terms of the time required and action necessary to obtain the desired results.
5. The ability of the user to control what they are doing, and where they are, at any given moment.

3. Literature background and hypothesis

3.1. Trust

This concept has received special attention in marketing literature due to the notable influence it has on the attainment of a long-lasting and profitable relationships [74,5,35,37,98]. Traditionally, trust is defined as a group of beliefs held by a person derived from his or her perceptions about certain attributes; in marketing this involves the brand, products or services,

¹ The International Organization for Standardization (ISO) is currently developing a new standard, specifically for website design, called ISO/AWI 23973 "Software ergonomics for World Wide Web user interfaces".

salespeople, and the establishment where the products or services are bought and sold [34]. This group of beliefs has been divided into different dimensions and trust is usually considered a multidimensional construct that differentiates between honesty and benevolence perceived in the behaviour of the other party. *Honesty* is the belief that another person will keep his or her word, fulfil promises and be sincere [38]. *Benevolence* is the belief that one of the parties is interested in the well-being of the other without intention of opportunistic behaviour [58] and motivated by a search for a mutually beneficial relationship [27]. Some researchers have discussed other dimensions of trust; e.g., in the perceived competence of the second party [89]. This is concerned with the perceived dexterity and ability of the second party [69,94]. Specifically, *competence* is the degree with which the consumer perceives that the supplier is in possession of the necessary knowledge and skills to complete an agreement or exchange. [19]. *Perceived competence* is especially relevant in an analysis of consumer Internet behaviour [83,88]; lack of knowledge about a relation can adversely affect the process. To this we must add a lack of knowledge of the medium itself. Little-known brands, insecurity about online payments, concern about order processing or conditions of delivery are all factors that oblige the business owner to show that the online business has financial, technical, and human resources necessary to satisfy the terms and conditions of the exchange agreement. Thus trust will be considered here as a construct made up of three dimensions: honesty, benevolence and competence perceived in a website.

Some authors have analysed the role of trust in online relationships by distinguishing different stages [72]. McKnight et al. [73] state that the consumer of a website overcomes a prior exploratory stage before being ready to carry out commercial transactions with it. In the exploration stage, the consumer has no direct experience with it, and thus trust is based on aspects such as perceived reputation, propensity to trust others, or presence of structural guarantees (such as independent testimonials). Once this first phase has been overcome, the consumer will decide to carry out riskier operations (e.g. make an order). This phase is the “*commitment stage*”. It is the individual’s experience with the website that determines the levels of trust at any moment. The present work deals with this second phase, since consumers who were

interviewed in our study already had experience in the use of the websites. Such experience allows the individual to create expectations about the events that may occur in future, and therefore decide whether to continue with the relationship. Consequently, trust is generated as a result of knowledge accumulation. The development of new exchanges broadens the information that the consumer has of the website’s qualities. This is added to the previous information and may even modify the trust between the parties.

Some research projects have analysed the importance of trust in Internet relationships [67,40,71, 59,14,32]. Insecurity of the consumer when shopping online has become one of the most important obstacles to the growth of e-commerce [56,106]. This is because a brick-and-mortar business gives the consumer a sense of privacy or reliability of communication that protects any exchange of financial information [55]. It has been argued [52,18,77] that website attributes (particularly usability) may influence the perceptions of the consumer about the website and thus of the expected degree of trust.

The ease of use of a computer system favours more complete learning and a greater capacity to infer how the system will act. Thus, usability may improve trust levels [29]. From a global perspective, we can establish several arguments about the influence of usability on trust:

- Greater usability favours a better comprehension of the contents and tasks that the consumer must realise to achieve an objective (e.g. make an order). This reduces the likelihood of error and improves consumer trust levels [75].
- Usability is related to consumer ability to know where he or she is at any time and what can be done. Self-confidence may be defined as a consumer feeling of security and ability about his or her decisions and behaviours [12]; thus we may establish a clear relationship between usability and self-confidence. Greater usability offers more security to website users. In addition, greater self-confidence might improve consumer trust in the website. Indeed, it has been proposed that familiarity and self-confidence favour greater trust in technology [49].
- Suitable design favours feelings of pleasure in use of the website. Consequently, greater usability

offers a comfortable atmosphere that might favour a more positive consumer disposition. Indeed, in traditional channels several authors have contrasted the influence of aspects such as colour on the feelings of pleasure of the buyer [13].

Furthermore, considering the multidimensional structure of trust we offer additional arguments:

- Honesty is related to information transparency. Given that greater usability favours greater transparency, we assume that honesty (trust) might be improved.
- Greater usability may be perceived as a signal of benevolence. Thus, greater ease of use would be interpreted as the desire to adjust to consumer needs.

Low levels of usability may generate errors on order processing, such as ordering undesired products or problems in the payment. Such errors increase feelings of distrust and discourage future transactions. We believe that usability may influence perceived competence significantly.

Based on this, we state the following hypothesis:

H1. The degree of website usability perceived by the consumer has a direct and positive influence on the degree of trust shown in that same website.

3.2. Satisfaction

In general terms, we define satisfaction as an affective consumer condition that results from a global evaluation of all the aspects that make up the consumer relationship [7]. The development of satisfaction follows a similar process to that of trust. Satisfaction shows a favourable attitude of the consumer. This is a response to long-term consistency of company behaviour [26]. With each new interchange, the individual's perception is fed by new information. It is this that determines the level of satisfaction at any given time [23].

Research into parameters that influence levels of Internet consumer satisfaction are in their early stages and are still scarce [17,51]. Some work has looked at factors that affect satisfaction among website users [76]. Spiller and Loshe [100] point to the influence of website design on the degree of

Internet consumer satisfaction. As a consequence, we assume that though website design may not guarantee consumer satisfaction (there *are* other factors) it does have a direct influence. Therefore our second hypothesis is:

H2. Greater perceived website usability has a direct and positive influence on the degree of satisfaction of the user of that same website.

Satisfaction has been linked to the trust in a relationship [50,11]. This should be greater when the satisfaction that the business or product gives the consumer is greater. Consequently, the degree of trust is a consequence of the capacity of a business to satisfy the needs of its clients.

Selnes [93] stated that satisfaction and trust were concepts that refer to global evaluations, feelings, or attitudes by one party with respect to another, and, although related, these are different variables. One of the models put forward to explain the process by which satisfaction is generated is the expectation/disconfirmation theory [82]; it arose from Helson's theory of the degree of adaptation and states that the degree of an individual's satisfaction depends on the relationship between the initial expectations created and the results obtained. Satisfaction therefore depends on the difference between what a consumer wants and what he or she obtains; there may also be other tangible aspects, such as delivery time or system security. However, according to Johnson and Grayson [44] expectation may be linked to intangible questions, such as: feelings of joy, fear, and anger associated with the service experience or the fulfilment of certain standards. The consumer will feel satisfied if he perceives the fulfilment of the required level of honesty, benevolence and competence in the website. Therefore, as satisfaction can act as an instrument to engender greater trust, we formulate our third hypothesis:

H3. Greater website user satisfaction has a direct and positive influence on the degree of trust shown in that same website.

3.3. Loyalty

As a consequence of the growing importance of Internet services, a number of researchers have

attempted to find ways to improve website fidelity and increase the consumer's intention to buy [1]. Going further, as website loyalty seems to depend on consumer skills in managing and controlling the website, cognitive lock-in [45], supposes that the consumer's familiarity with a website (and acquisition of the skills to manage and control it), lessens the likelihood of the consumer changing to another website [2,46]. Therefore, even when the cost of searching the Internet is low and when that search could yield a cheaper product, individuals limit their options and stick with websites with which they are familiar [24,61]. The acquisition of the necessary skills will not only depend on the time dedicated by the consumer to managing the website, but also on the facilities that the website offers its users. We therefore formulate the hypothesis:

H4. Greater perceived website usability has a direct and positive influence on the degree of user loyalty to that same website.

One study suggested that 49% of consumers are opposed to making purchases on the Internet due to lack of trust [104]. Lee et al. [60] stated that loyalty directly depends on the degree of trust. Similarly, Quelch and Klein [84] and Jarvenpaa et al. [43] pointed out that trust is a critical factor in stimulating purchase. Lack of technical knowledge, lack of knowledge of the agents operating in the digital market, a feeling of vulnerability, and the risk assumed by the individual all make trust a key factor; but the consumer shows opposition to distance shopping when it is associated with high levels of risk [103,28]. In fact, purchases made from home, by telephone [20] or mail [4] are considered high risk. We therefore postulate that:

H5. Greater website consumer trust leads to greater consumer loyalty to that same website.

Higher consumer satisfaction leads to greater individual loyalty [7,107]. More specifically, if the consumer believes that the organisation will fulfil the agreed conditions, they believe that this behaviour will continue and their predisposition to develop the relationship will increase [36]. At the same time, the alternatives in the market will be less attractive. Thus we hypothesise that fulfilment of the expectations of the website user will lead to an increase in intention to

buy in future, the user will visit the site more frequently, and spend more, as in other contexts [64].

H6. Greater consumer satisfaction with the services offered by a website will lead to a greater degree of loyalty towards that website.

4. Data collection

Following the suggestions of other researchers [92], a single dimension was used to quantify the variables of usability and satisfaction, measured using a multi-item scale. Quantifying satisfaction did not present difficulties, as reference could be made to many papers published. The measurement of usability, however, was a little more complex. Although a number of efforts made to quantify usability, most of the instruments (e.g. the SUS or SUMI scales) have not been submitted to adequate validation. Nevertheless, we developed our measure by considering the WAMMI scale. This has been analysed from a statistical perspective, though using a relatively simple factor (Cronbach alpha) and it has been the most frequent usability measurement in website design in several well-established firms, such as Compaq, Nokia, and Ericsson.

Trust was measured in terms of perceived website honesty, benevolence, and competence. Website loyalty was measured on two dimensions that reflected the consumer's behaviour at a specific website (see Appendix A, the LOY_A dimension) and also at a competitor's website (see Appendix A, the LOY_B dimension). This therefore considers the influence of website competitors and their power to modify consumer behaviour.

In order to guarantee the content validity of the questionnaire we first analyse previous literature. The trust scale was developed using the works of Kumar et al. [57], Siguaw et al. [96], Doney and Cannon [27], and Roy et al. [88]; the proposals of Brockman [15], Janda et al. [42] and Smith and Barclay [99] were used for satisfaction; while perceived website usability used Roy et al. [88], Lin et al. [63] and Kirakowski et al. [54]; while the concept of loyalty made reference to the work of Rowley and Dawes [87], Yoon and Kim [107], and Flavián et al. [30]. The initial scales had to be adapted to the context and framework of the research. The scales of trust, loyalty and satisfaction were adapted because prior scales were developed based on literature dealing

with traditional distribution channels. However, the WAMMI scale has been mainly used by professional projects, so that its utility for academic studies is not guaranteed. Following the recommendations of De Wulf and Odekerken-Schröder [25], this adaptation was based on opinions expressed in a Delphi process by various experts in e-marketing and website design, as well as a series of in-depth interviews with about a dozen Internet consumers. Moreover, a quantitative pre-test was conducted with a sample of 30 users, based on exploratory factor and Cronbach alpha analyses. The aim of these initial siftings was to ensure that the questions posed were understood correctly, as well as to include the most pertinent aspects in the measuring of concepts. The final version of the scales that were used can be seen in [Appendix A](#).

Once the initial questionnaire had been constructed, it was published on a website that was designed specifically for our project; subjects were provided with all the information about the research project. Those who wished to complete the questionnaire could make a hard copy or complete it on their PCs; it could then be returned via e-mail, fax or mail. To increase the response rate, two extra activities were carried out. Firstly, we used a publicity campaign by inserting banners on well-known, heavy traffic online media sites, as well as on discussion forums, Usenet and mailing lists that were collaborating in the project. This effort was accomplished in March 2003. Secondly, we provided a prize, selected by drawing randomly from among participants. The variables were measured using a Likert scale of 1–7 points.

Once refined, excluding repeat questionnaires and atypical or missing data, there were 351 valid samples. This gave us a sample error of 5.2% (95% degree of confidence).

Internet users who responded could choose a website to be analysed provided that they had habitually made acquisitions there (several times per month during the previous year) and that the website selected was popular or well known to Internet users. To check that this was true, they were asked control questions, such as: What operations had they carried out at the website?

In qualitative terms, the representativity of the sample was high; most of the websites had a high volume of users and a large variety of product categories. Specifically, websites analysed were very well known Internet servers offering financial services

(e.g. BBVA or ING); book and music retailers (e.g. Amazon or Fnac) and travel or tourist services (e.g. Virgin Express).

Good representation occurred: the data showed that the profile of the user that completed our questionnaire was very similar to that of the average Internet user, as defined by various studies [3]. The majority were between 25 and 34 years old (53%), males (67%), incomes between 1200 and 1800 euros per month (40%); in general they had a good educational level (81% higher education); 87% had more than 5 years experience using computers, although there were fewer with the same experience of the Internet (44%); they showed a high frequency of Internet access with 83% logging on several times a day; 94% said that they accessed the Internet “yesterday”.

5. Reliability, dimensionality, and validity of scales

5.1. Analysis of initial reliability

All the scales used were above the recommended 0.7 for Cronbach alpha [80] and 0.3 on the item-total correlation [81]. The minimum value of the item-total correlation in all fields was well over the minimum recommended. The uni-dimensionality of the scales was analysed using a factorial exploratory analysis of the principal components, and, where necessary, with a varimax rotation [70]. In all cases, the results obtained were clearly satisfactory (see [Table 1](#)).²

5.2. Confirmatory analysis of reliability and dimensionality

The measurement scales were refined through the development of a strategy of confirmatory models [39]. Statistical software EQS version 5.7b was used for this analysis. We used Robust Maximum Like-

² As an estimation method, we decided on Robust Maximum Likelihood, as it operates with greater security in samples that do not unequivocally overcome the multivariate normality test. Nevertheless, it is worth noting that this methodology is especially recommendable for samples of less than 300. The results obtained should be analysed considering that some adjustment indicators might give relatively unsatisfactory results as a consequence of the sensitivity of the estimation method and the sample size.

Table 1
Analysis of initial reliability

	HON	BEN	COM	SAT	USAB	LOY_A	LOY_B
Cronbach alpha	0.9104	0.8296	0.8849	0.9345	0.9011	0.7667	0.8190
No. of factors	1	1	1	1	1	1	1
Variance explained (%)	74.221	67.563	63.677	83.600	61.895	69.198	74.670
Factorial loadings	>0.5	>0.5	>0.5	>0.5	>0.5	>0.5	>0.5

Table 2
Ave and composite reliability coefficient. Convergent and discriminatory validity

	Correlations	Confidence interval	Differential χ^2		AVE	Composite reliability
HON-BEN	0.74*	(0.68; 0.80)	209*	HON	0.55	0.86
HON-COM	0.66*	(0.57; 0.74)	142*	BEN	0.46	0.84
HON-USAB	0.71*	(0.37; 0.58)	78*	COM	0.47	0.78
HON-SAT	0.48*	(0.65; 0.78)	203*	USAB	0.51	0.88
HON-LOY_A	0.11*	(0.03; 0.22)	6*	SAT	0.64	0.88
HON-LOY_B	0.34*	(0.21; 0.47)	34*	LOY_A	0.52	0.76
BEN-COM	0.83*	(0.77; 0.88)	247*	LOY_B	0.61	0.76
BEN-USAB	0.50*	(0.40; 0.59)	84*			
BEN-SAT	0.59*	(0.49; 0.68)	121*			
BEN-LOY_A	0.14*	(0.03; 0.24)	8*			
BEN-LOY_B	0.35*	(0.22; 0.48)	36*			
COM-USAB	0.53*	(0.43; 0.63)	90*			
COM-SAT	0.52*	(0.42; 0.62)	86*			
COM-LOY_A	0.09	(-0.01; 0.19)	4*			
COM-LOY_B	0.32*	(0.19; 0.44)	28*			
USAB-SAT	0.50*	(0.39; 0.61)	91*			
USAB-LOY_A	0.08	(-0.03; 0.20)	1*			
USAB-LOY_B	0.28*	(0.17; 0.39)	27*			
SAT-LOY_A	0.14*	(0.03; 0.24)	8*			
SAT-LOY_B	0.42*	(0.29; 0.54)	48*			
LOY_A-LOY_B	0.55*	(0.44; 0.66)	80*			

*d.f. = 1; $p < 0.01$.

likelihood, as it operates well in samples that do not unequivocally overcome the multivariate normality test. Any indicators that did not fulfil one of the three criteria proposed by Jöreskog and Sörbom [47]³ were eliminated. Specifically, two items, USAB8 and LOY_A1 did not reach a high enough R^2 and were discarded. Later work with the goodness-of-fit test found that all the confirmatory models were acceptable. Finally, the scales that had changed their

structure since the initial exploratory analysis were put to a new reliability valuation using the Cronbach alpha criteria and the item-total correlation. At the same time, all the scales fulfilled the two validity confirmation indicators normally used (see Table 2); composite reliability coefficient [48] and the average variance extracted or AVE [33].

In order to contrast the presence of a multidimensional structure in the two existing multidimensional constructs (trust and loyalty), a rival model strategy was developed; it consisted of a comparison of two alternative models [6]: a first order factorial model in which the dimensions were not differentiated, and a second order model [101] with two dimensions for loyalty and three for trust. The results showed a higher fit in the second order model, which allowed us to confirm the multidimensionality of the variables.

³ (1) Criteria of weak convergence, would eliminate indicators that did not have a significant factorial regression coefficient (Student's $t > 2.58$; $p = 0.01$). (2) Criteria of strong convergence would eliminate those indicators that were not substantial, i.e. those whose standardised coefficient is less than 0.5 [41]. (3) Lastly, it has been proposed the elimination of those indicators that least contribute to the explanation of the model, considering the cut-off point as $R^2 < 0.3$.

5.3. Validation analysis

This validation consists of convergent and discriminant validity [31]. For uni-dimensional variables (satisfaction and usability), convergent validity was confirmed by checking that the weight of the different indicators in the confirmatory model was statistically significant (to 0.01) and more than 0.5 points [90]. For the multi-dimensional variables (trust and loyalty), in addition to testing the significance and size of the indicators of each dimension, the correlations between the different proposed dimensions was also verified and they were found to be significant (to 0.01) and high [66]. The discriminatory validity was confirmed through three distinct criteria. Firstly, the correlation between the different variables in the confirmatory models was tested to make sure that they did not exceed 0.8 points, as this would indicate a low discrimination between them [9]. Secondly, we checked that a value of 1 did not show that it was in the confidence interval of the correlations between the different variables of the confirmatory model. Finally, the correlation between each pair of confirmatory model variables was fixed at 1 and a Chi-squared difference test was carried out [10]. The evaluation of all the discrimination criteria gave us sufficient discriminant validity. The data corresponding to convergent and discriminatory validity can be seen in Fig. 1 and Table 2.

6. Structural model analysis

Once the measurement scales were designed and validated, we contrasted the hypotheses that made up the structural model [8]; see Fig. 1. For the multi-dimensional variables (trust and loyalty), the indicators that were taken for causal analysis were derived from the arithmetical average of the items that made up each of the dimensions. This common research practice allowed us to reduce the number of parameters to be estimated and therefore made model adjustment and understanding easier. Nevertheless, these measurements could not have been used without the guarantee of reliability, dimensionality, and validity, based on the second order factorial models that confirmed the existence of robust multi-dimensional structures.

The goodness-of-fit was greater than or close to the recommended limits (see Fig. 1). With regard to the proposed hypotheses, it was noted that consumer trust and satisfaction positively and directly depended on perceived usability, as shown by the significance and sign of the parameters. Therefore, it was not possible to reject hypotheses H1 and H2. It was also observed that as levels of consumer satisfaction improved, as did website trust, and this meant that we could not reject hypothesis H3. On the other hand, hypothesis H4 had to be rejected as it did not show sufficient statistical significance. It was found however, that higher levels of trust and satisfaction have a significant effect on website loyalty, so it was not possible to reject hypotheses H5 and H6. In conclusion, the effect of usability on loyalty seems to be conditioned by consumer trust and satisfaction.

7. Recommendations and limitations

The high costs involved in increasing the client base of a business are forcing companies to look for ways to retain their consumers. Gaining a higher level of customer fidelity has become a key objective. Our research has confirmed that perceived usability has a direct and positive relationship on the degree of consumer trust and satisfaction. Moreover, it has shown that the effect of the degree of usability on the degree of consumer loyalty does not follow a direct path but is conditioned by the role that trust and satisfaction play with respect to the individual's fidelity. Finally, website user satisfaction favours trust in that website.

Company strategies should be designed to achieve two basic objectives: a higher level of usability and a higher level of customer satisfaction. User satisfaction depends on the fulfilment of their expectations. Therefore, a detailed analysis of the needs of the website user should be undertaken, with the aim of developing more adequate strategies and assigning the necessary resources in the most efficient way possible. The focus should be on giving the customer an adequate system that eases the acquisition of the necessary knowledge and a more personalised, closer customer attention which increases the level of individual satisfaction. Moreover, management should concentrate on designs and structures that are simple and easy for the user to understand.

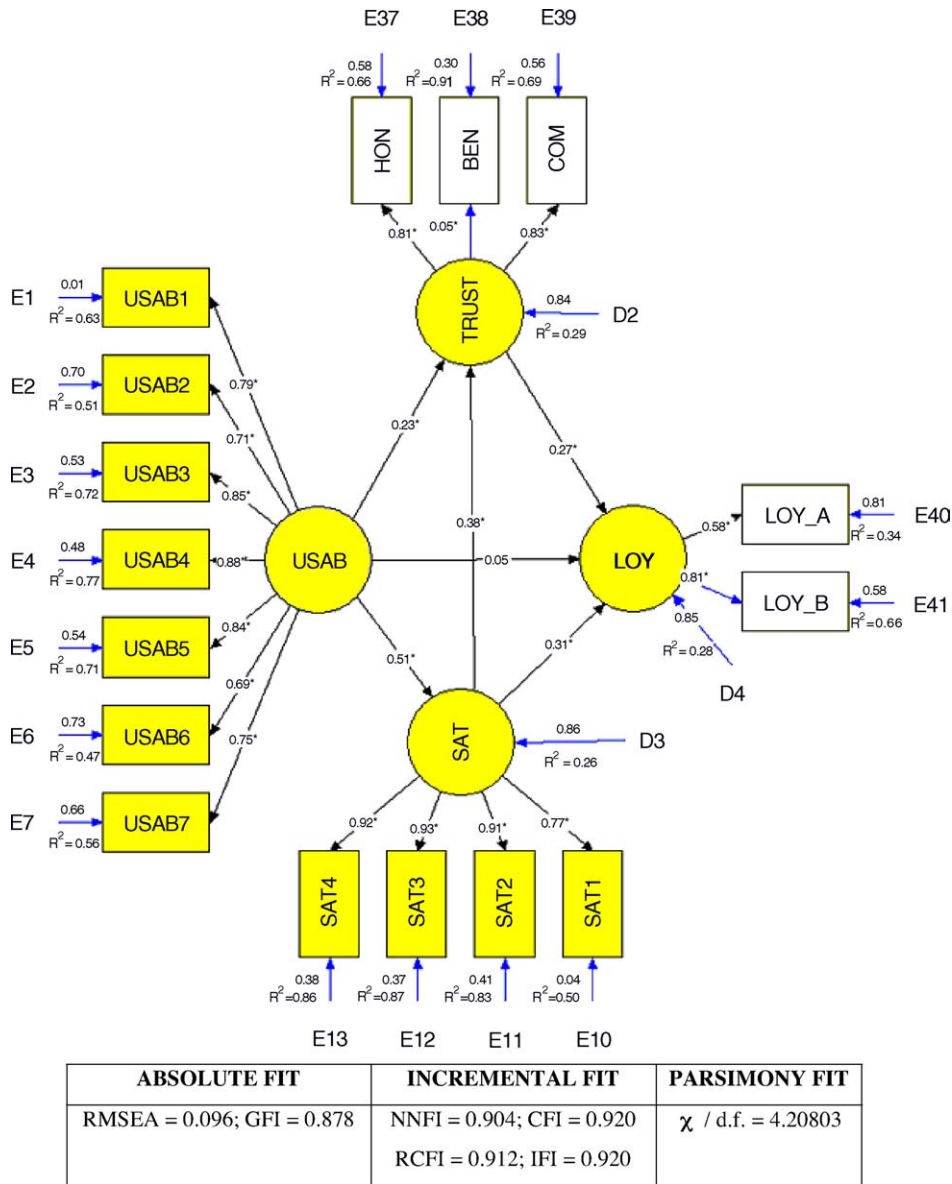

Fig. 1. Structural model of the relationship between perceived website usability, trust, satisfaction and loyalty. (*) Coefficients significant to level 0.01.

Turning to the limitations of our work, we first must point out that the majority of individuals who participated were Spanish speaking. While the sample size and variety of websites analysed enabled us to make generalisations, it may not hold for different nationalities. Secondly, although the

majority of the proposal relationships were validated, particularly noticeable are the relative low levels of R^2 obtained for trust, satisfaction and loyalty (0.29, 0.26 and 0.28, respectively). These levels show that there are other variables that may influence our results.

Acknowledgements

The authors are grateful for the financial support received from the Aragon Regional Government

(S-46; PM-034), FUNDEAR and the University of Zaragoza (UZ2002-SOC-06). The authors are grateful to Professor Sibley for its useful comments.

Appendix A. Measurement scales used

The individual is asked to grade from 1 to 7 their level of agreement or disagreement with the following statements in relation to the selected website or a website with which they have substantial experience.

Scale for measuring perceived website usability		Adapted from
USAB1	In this website everything is easy to understand	[54,63,88]
USAB2	This website is simple to use, even when using it for the first time	[54,63,88]
USAB3	It is easy to find the information I need from this website	[54,63,88]
USAB4	The structure and contents of this website are easy to understand	New item
USAB5	It is easy to move within this website	[54,63,88]
USAB6	The organisation of the contents of this site makes it easy for me to know where I am when navigating it	New item
USAB7	When I am navigating this site, I feel that I am in control of what I can do	[54,63,88]
USAB8	Downloading pages from this website is quick	[54,63,88]
Scale for measuring website user trust		
HON1	I think that this website usually fulfils the commitments it assumes	[27,57,88,96]
HON2	I think that the information offered by this site is sincere and honest	[27,57,88,96]
HON3	I think I can have confidence in the promises that this website makes	[27,57,88,96]
HON4	This website does not make false statements	[27,57,88,96]
HON5	This website is characterised by the frankness and clarity of the services that it offers to the consumer	[27,57,88,96]
BEN1	I think that the advice and recommendations given on this website are made in search of mutual benefit	[27,57,88,96]
BEN2	I think that this website is concerned with the present and future interests of its users	[27,57,88,96]
BEN3	I think that this website takes into account the repercussions that their actions could have on the consumer	[27,57,88,96]
BEN4	I think that this website would not do anything intentional that would prejudice the user	[27,57,88,96]
BEN5	I think that the design and commercial offer of this website take into account the desires and needs of its users	[27,57,88,96]
BEN6	I think that this website is receptive to the needs of its users	[27,57,88,96]
COM1	I think that this website has the necessary abilities to carry out its work	[27,57,88,96]
COM2	I think that this website has sufficient experience in the marketing of the products and services that it offers	[27,57,88,96]
COM3	I think that this website has the necessary resources to successfully carry out its activities	[27,57,88,96]
COM4	I think that this website knows its users well enough to offer them products and services adapted to their needs	[27,57,88,96]
Scale for measuring website user satisfaction		
SAT1	I think that I made the correct decision to use this website	[15,42,94,99]
SAT2	The experience that I have had with this website has been satisfactory	[15,42,94,99]
SAT3	In general terms, I am satisfied with the way that this website has carried out transactions	[15,42,94,99]
SAT4	In general, I am satisfied with the service I have received from the website	[15,42,94,99]
Scale for measuring website user loyalty		
LOY_A1	I visit this website more frequently than others of the same category	[30,87,107]
LOY_A2	This is the website where I purchase the majority of the products and services in this Internet category	[30,87,107]
LOY_A3	This is my favourite site for purchasing the products and services in this Internet category	[30,87,107]
LOY_B1	Not counting this website, in the last few months I have visited very few sites that offer similar products and services	[30,87,107]
LOY_B2	The frequency with which I visit other websites that offer similar products and services is much less	[30,87,107]
LOY_B3	I don't usually purchase products and services from this category from other websites	[30,87,107]

Note: The questions in italics were eliminated in the refinement process. These scales were presented in Spanish due to the interviewee's nationality.

References

- [1] M. Abbott, K. Chiang, Y. Hwang, J. Paquin, D. Zwick, The process of online store loyalty formation, *Advances in Consumer Research* (27) 2000, pp. 145–150.
- [2] L. Adamic, B. Huberman, The nature of markets in the World Wide Web, *Quarterly Journal of Electronic Commerce* (1) 2000, pp. 5–12.
- [3] AECE, Estudio comercio electrónico B2C en España, 2003, <http://www.aece.org>.
- [4] J. Akaah, P. Korgaonkar, A conjoint investigation of the relative importance of risk relievers in direct marketing, *Journal of Advertising Research* 28(4), 1998, pp. 38–44.
- [5] S. Andaleeb, An experimental investigation of satisfaction and commitment in marketing channels: the role of trust and dependence, *Journal of Retailing* 72(1), 1996, pp. 77–93.
- [6] J. Anderson, D. Gerbing, Structural modeling in practice: a review and recommended two-step approach, *Psychological Bulletin* 103(3), 1988, pp. 411–423.
- [7] E. Anderson, M. Sullivan, The antecedents and consequences of customer satisfaction for firms, *Management Science* 12(2), 1993, pp. 125–143.
- [8] R. Bagozzi, Evaluating structural equations models with unobservable variables and measurement error: a comment, *Journal of Marketing Research* (18) 1981, pp. 375–381.
- [9] R. Bagozzi, Structural equation model in marketing research. basic principles, *Principles of Marketing Research*, Blackwell Publishers, Oxford, 1994.
- [10] R. Bagozzi, Y. Yi, On the evaluation of structural equation models, *Journal of the Academy of Marketing Science* 16(1), 1988, pp. 74–94.
- [11] H. Bauer, M. Grether, M. Leach, Building customer relations over the Internet, *Industrial Marketing Management* (31) 2002, pp. 155–163.
- [12] W.O. Bearden, D.M. Hardesty, R.L. Rose, Consumer self-confidence: refinements in conceptualisation and measurement, *Journal of Consumer Research* (28) 2001, pp. 121–134.
- [13] J.A. Bellizzi, R.E. Hite, Environmental colour, consumer feelings, and purchase likelihood, *Psychology and Marketing* (9) 1992, pp. 347–363.
- [14] S. Bomil, H. Ingo, The impact of customer trust and perception of security control on the acceptance of electronic commerce, *International Journal of Electronic Commerce* 7(3), 2002, pp. 135, 161.
- [15] B. Brockman, The influence of affective state on satisfaction ratings, *Journal of Consumer Satisfaction, Dissatisfaction and Complaining Behavior* (11) 1998, pp. 40–50.
- [16] H. Chen, R. Wigand, M. Nilan, Optimal experience of web activities, *Computers in Human Behavior* (15) 1999, pp. 585–608.
- [17] Q. Chen, W. Wells, .Com satisfaction and .Com dissatisfaction: one or two constructs? *Advances in Consumer Research* (28) 2001, pp. 34–39.
- [18] Cheskin Research, Trust in the wired Americas, 2000, <http://www.cheskin.com/think/studies/trust2.html>.
- [19] K. Coulter, R. Coulter, Determinants of trust in a service provider: the moderating role of length of relationship, *Journal of Services Marketing* 16(1), 2002, pp. 35–50.
- [20] D. Cox, S. Rich, Perceived risk and consumer decision making, *Journal of Marketing Research* (1) 1964, pp. 32–39.
- [21] M. Dahlén, F. Lange, Real consumers in the virtual store, *Scandinavian Journal of Management* (18) 2002, pp. 341–363.
- [22] F. Davis, Perceived usefulness, perceived ease of use, and user acceptance of information technology, *MIS Quarterly* 13(3), 1989, pp. 319–340.
- [23] R. Day, Modeling choices among alternative responses to dissatisfaction, in: W.D. Perreault (Ed.), *Advances in Consumer Research*, (vol. 11), Association for Consumer Research, Atlanta, GA, 1984.
- [24] J. De Figueiredo, Finding sustainable profitability in electronic commerce, *Sloan Management Review* 2000, pp. 41–52.
- [25] K. De Wulf, G. Odekerken-Schröder, Assessing the impact of a retailer's relationship efforts on consumer' attitudes and behaviour, *Journal of Retailing and Consumer Services* 10(2), 2003, pp. 95–108.
- [26] E. Delgado, J.L. Munuera, Brand trust in the context of consumer loyalty, *European Journal of Marketing* 35(11–12), 2001, pp. 1238–1258.
- [27] P. Doney, J. Cannon, An examination of the nature of trust in the buyer–seller relationship, *Journal of Marketing* (51) 1997, pp. 35–51.
- [28] N. Donthu, A. Garcia, The internet shopper, *Journal of Advertising Research* 39(3), 1999, pp. 52–58.
- [29] F. Egger, From Interactions to Transactions: Designing the Trust Experience for Business-to-Consumer Electronic Commerce, Ph.D. Thesis, Eindhoven University of Technology, The Netherlands, 2003.
- [30] C. Flavián, E. Martínez, Y. Polo, Loyalty to grocery stores in the Spanish market of the 1990's, *Journal of Retailing and Consumer Services* 8(2), 2001, pp. 85–93.
- [31] C. Flavián, F. Lozano, Diseño de una escala para medir la orientación al entorno de la nueva formación profesional, *Cuadernos de Economía y Dirección de la Empresa* (15) 2003, pp. 333–363.
- [32] B. Fogg, T. Kameda, J. Boyd, J. Marshall, R. Sethi, M. Sockol, T. Trowbridge, Stanford-Makovsky Web Credibility Study 2002: Investigating what makes Websites credible today. A Research Report by the Stanford Persuasive Technology Lab and Makovsky & Company, Stanford University, 2002, <http://www.webcredibility.org>.
- [33] C. Fornell, D. Larcker, Structural equation models with unobserved variables and measurement error, *Journal of Marketing Research* (18) 1981, pp. 39–50.
- [34] S. Ganesan, Determinants of long-term orientation in buyer–seller relationship, *Journal of Marketing* (58) 1994, pp. 1–19.
- [35] I. Geyskens, J. Steenkemp, N. Kumar, Generalizations about trust in marketing channel relationships using meta-analysis, *International Journal of Research in Marketing* (15) 1998, pp. 223–248.
- [36] C. Grönroos, *Marketing y Gestión de Servicios. La gestión de los momentos de la verdad y la competencia en los servicios*, Díaz de Santos, Madrid, 1994.

- [37] C. Grönroos, Relationship marketing logic, *Asia-Australia Marketing Journal* (4) 1996, pp. 7–18.
- [38] G. Gundlach, P.E. Murphy, Ethical and legal foundations of relational marketing exchanges, *Journal of Marketing* (57) 1993, pp. 35–46.
- [39] J. Hair, R. Anderson, R. Tatham, W. Black, *Análisis Multivariante*, Prentice Hall, Madrid, 1999.
- [40] R. Hershel, P. Andrews, Ethical implications of technological advances on business communication, *Journal of Business Communications* (34) 1997, pp. 160–170.
- [41] L. Hildebrandt, Consumer retail satisfaction in rural areas: a reanalysis of survey data, *Journal of Economic Psychology* (8) 1987, pp. 19–42.
- [42] S. Janda, P. Trocchia, K. Gwinner, Consumer perceptions of Internet retail service quality, *International Journal of Service Industry Management* 13(5), 2002, pp. 412–431.
- [43] S. Jarvenpaa, N. Tractinsky, M. Vitale, Consumer trust in an Internet store, *Information Technology and Management* 1(1–2), 2000, pp. 45–71.
- [44] D. Johnson, K. Grayson, Cognitive and affective trust in service relationships, *Journal of Business Research* (58) 2005, pp. 500–507.
- [45] E. Johnson, S. Bellman, G. Lohse, What makes a website ‘sticky’? Cognitive lock-in and the power law of practice, Working Paper, Columbia School of Business, Columbia University, New York, 2000.
- [46] E. Johnson, W. Moe, P. Fader, S. Bellman, G. Lohse, On the depth and dynamics of online search behavior, Working paper, The Wharton School, University of Pennsylvania, 2000.
- [47] K. Jöreskog, D. Sörbom, *LISREL 8 Structural Equation Modeling with the SIMPLIS Command Language*, Scientific Software International, Chicago, IL, 1993.
- [48] K. Jöreskog, Statistical analysis of sets of congeneric tests, *Psychometrika* (36) 1971, pp. 109–133.
- [49] B.H. Kantowitz, R.J. Hankowski, S.C. Kantowitz, Driver acceptance of unreliable traffic information in familiar and unfamiliar settings, *Human Factors* 39(2), 1997, pp. 164–176.
- [50] M. Kennedy, L. Ferrell, D. LeClair, Consumer’s trust of salesperson and manufacturer: an empirical study, *Journal of Business Research* (51) 2001, pp. 73–86.
- [51] M. Khalifa, V. Liu, Satisfaction with Internet-based services: the role of expectations and desires, *International Journal of Electronic Commerce* 7(2), 2002, pp. 31–50.
- [52] J. Kim, J. Moon, Designing towards emotional usability in customer interfaces ± trustworthiness of cyber-banking system interfaces, *Interacting with Computers* 10(1), 1998, pp. 1–29.
- [53] E. Kim, S. Eom, Designing effective cyber store user interface, *Industrial Management and Data Systems* 102(5), 2002, pp. 241–251.
- [54] J. Kirakowski, N. Claridge, R. Whitehead, Human centered measures of success in website design, in: *Proceedings of the Fourth Conference on Human Factors and the Web*, 1998.
- [55] A. Kolsaker, C. Payne, Engendering trust in e-commerce: a study of gender-based concerns, *Marketing Intelligence and Planning* 20(4), 2002, pp. 206–214.
- [56] P. Korgaonkar, L. Wolin, A multivariate analysis of web usage, *Journal of Advertising Research* (2) 1999, pp. 53–68.
- [57] N. Kumar, L. Scheer, J. Steenkamp, The effects of supplier fairness on vulnerable resellers, *Journal of Marketing Research* 32(1), 1995, pp. 42–53.
- [58] R. Larzelere, T. Huston, The dyadic trust scale: toward understanding interpersonal trust in close relationships, *Journal of Marriage and the Family* 42(3), 1980, pp. 595–604.
- [59] M. Lee, E. Turban, Trust model for consumer internet shopping, *International Journal of Electronic Commerce* 6(1), 2001, pp. 75–91.
- [60] J. Lee, J. Kim, J. Moon, What makes Internet users visit cyber stores again? Key design factors for customer loyalty in: *Proceedings of the Conference on Human Factors in Computing Systems CHI 2000*, ACM, New York, 2000, pp. 305–312.
- [61] T. Lewis, *The Friction-Free Economy: Strategies for Success in a Wired World*, Harper Collins, New York, NY, 1997.
- [62] T. Liang, H. Lai, Effect of store design on consumer purchases: van empirical study of online bookstores, *Information and Management* (39) 2002, pp. 431–444.
- [63] H. Lin, Y. Choong, G. Salvendy, A proposed index of usability: a method for comparing the relative usability of different software systems, *Behaviour and Information Technology* 16(4–5), 1997, pp. 267–278.
- [64] J. Littlefield, Y. Bao, D. Cook, Internet real estate information: are home purchasers paying attention to it? *Journal of Consumer Marketing* 17(7), 2000, pp. 575–590.
- [65] G. Loshe, P. Spiller, Internet retail store design: how the user interface influences traffic and sales, *Journal for Computer-Mediated Communication* 5 (2) (1999), <http://www.ascusc.org/jcmc/vol5/issue2/lohse.htm>.
- [66] F. Lozano, *La Orientación Al Mercado En El Contexto Universitario Español Un Análisis De Sus Antecedentes, Moderadores y Consecuencias*, Doctoral Thesis, University of Zaragoza, Spain, 2002.
- [67] X. Luo, Trust production and privacy concerns on the Internet. A framework based on relationship marketing and social exchange theory, *Industrial Marketing Management* (31) 2002, pp. 111–118.
- [68] N. Mandel, E. Johnson, Constructing preferences online: can web pages change what you want? Working Paper, Wharton School, University of Pennsylvania, 1999.
- [69] R. Mayer, J. Davis, F. Shoorman, An integrative model of organizational trust, *Academy of Management Review* 20(3), 1995, pp. 709–734.
- [70] R. McDonald, The dimensionality of test and items, *British Journal of Mathematical and Statistical Psychology* (34) 1981, pp. 100–117.
- [71] D. McKnight, N. Chervany, What trust means in e-commerce customer relationships: an interdisciplinary conceptual typology, *International Journal of Electronic Commerce* 6(2), 2002, pp. 35–59.
- [72] D.H. McKnight, L.L. Cummings, N.L. Chervany, Initial trust formation in new organizational relationships, *Academy of Management Review* (23) 1998, pp. 473–490.

- [73] D.H. McKnight, V. Choudhury, C. Kacmar, Trust in e-commerce vendors: a two-stage model, in: Proceedings of the 21st International Conference on Information Systems, 2000, pp. 532–536.
- [74] R. Morgan, S. Hunt, The commitment–trust theory of relationship marketing, *Journal of Marketing* (58) 1994, pp. 20–38.
- [75] B.M. Muir, N. Moray, Trust in automation. Part II. Experimental studies of trust and human intervention in a process control simulation, *Ergonomics* 39(3), 1996, pp. 429–460.
- [76] S. Muylle, R. Moenaert, M. Despontin, The conceptualization and empirical validation of website user satisfaction, *Information and Management* 41(5), 2004, pp. 543–560.
- [77] J. Nielsen, D. Norman, Usability on the Web isn't a luxury, 2000, <http://www.informationweek.com/773/web.htm>.
- [78] J. Nielsen, Usability 101, 2003, <http://www.useit.com/alert-box/20030825.html>.
- [79] J. Nielsen, Usability Engineering, Morgan Kaufmann, San Francisco, 1994.
- [80] J. Nunnally, Psychometric Theory, 2nd ed., McGraw-Hill, New York, 1978.
- [81] M. Nurosis, SPSS. Statistical Data Analysis, SPSS Inc., 1993
- [82] R. Oliver, A cognitive model of the antecedents and consequences of satisfaction decisions, *Journal of Marketing Research* (14) 1980, pp. 495–507.
- [83] P. Pavlou, Consumer acceptance of electronic commerce: integrating trust and risk with the technology acceptance model, *International Journal of Electronic Commerce* 7(3), 2002, pp. 101–134.
- [84] J. Quelch, L. Klein, The internet and international marketing, *Sloan Management Review* 1996, pp. 60–75.
- [85] A. Raijas, The consumer benefits and problems in the electronic grocery store, *Journal of Retailing and Consumer Services* 9(2), 2002, pp. 107–113.
- [86] C. Ranganathan, S. Ganapathy, Key dimensions of B2C websites, *Information and Management* (39) 2002, pp. 457–465.
- [87] J. Rowley, J. Dawes, Disloyalty: a closer look at non-loyals, *Journal of Consumer Marketing* 17(6), 2000, pp. 538–549.
- [88] M. Roy, O. Dewit, B. Aubert, The impact of interface usability on trust in web retailers, *Internet Research: Electronic Networking Applications and Policy* 11(5), 2001, pp. 388–398.
- [89] M. Sako, S. Helper, Determinants of trust in supplier relations: evidence from the automotive industry in Japan and the United States, *Journal of Economic Behaviour and Organization* 34(3), 1997, pp. 387–417.
- [90] M. Sanzo, M. Santos, R. Vázquez, L. Álvarez, The effect of market orientation on buyer–seller relationship satisfaction, *Industrial Marketing Management* 32(4), 2003, pp. 327–345.
- [91] B. Schneiderman, *Designing the User Interface*, Addison-Wesley, Reading, MA, 1998.
- [92] F. Selnes, An examination of the effect of product performance on brand reputation, customer satisfaction and loyalty, *European Journal of Marketing* 27(9), 1993, pp. 19–35.
- [93] F. Selnes, Antecedents and consequences of trust and satisfaction in buyer–seller relationships, *European Journal of Marketing* 32(3/4), 1998, pp. 305–322.
- [94] E. Severt, The Customer's Path to Loyalty: A Partial Test of the Relationships of Prior Experience, Justice, and Customer Satisfaction, Doctoral Thesis, Faculty of the Virginia Polytechnic Institute and State University (EEUU), 2002.
- [95] C. Shapiro, H. Varian, *Information Rules*, Harvard Business School Press, Boston, MA, 1999.
- [96] J. Siguaw, P. Simpson, T. Baker, Effects of supplier market orientation on distributor market orientation and the channel relationship: the distributor perspective, *Journal of Marketing* (62) 1998, pp. 99–111.
- [97] L. Sim, S. Koi, Singapore's internet shoppers and their impact on traditional shopping patterns, *Journal of Retailing and Consumer Services* 9(2), 2002, pp. 115–124.
- [98] D. Sirdeshmukh, J. Singh, B. Sabol, Consumer trust, value, and loyalty in relational exchanges, *Journal of Marketing* (66) 2002, pp. 15–37.
- [99] J. Smith, D. Barclay, The effects of organizational differences and trust on the effectiveness of selling partner relationships, *Journal of Marketing* (61) 1997, pp. 3–21.
- [100] P. Spiller, G. Loshe, A classification of the Internet retail stores, *International Journal of Electronic Commerce* 2(2), 1998, pp. 29–56.
- [101] J. Steenkamp, H. Van Trijp, The use of LISREL in validating marketing constructs, *International Journal of Research in Marketing* (8) 1991, pp. 283–299.
- [102] V. Swaminathan, E. Lepkowska-White, B. Rao, browsers or buyers in cyberspace? an investigation of factors influencing electronic exchange, *Journal of Computer-Mediated Communication* 5 (2) (1999), <http://www.ascusc.org/jcmc/vol5/issue2/swaminathan.htm>.
- [103] S. Tan, Strategies for reducing customer's risk aversion and internet shopping, *Journal of Consumer Marketing* 16(2), 1999, pp. 163–180.
- [104] TRUSTE, Identity theft and spam will deter online shopping this holiday season, 2003, <http://truste.org/about/Holiday-ShoppingandPrivacySurvey.htm>.
- [105] P. Verhoef, F. Langerak, Possible determinants of consumers' adoption of electronic grocery shopping in the Netherlands, *Journal of Retailing and Consumer Services* (8) 2001, pp. 275–285.
- [106] H. Wang, M. Lee, C. Wang, Consumer privacy concerns about Internet marketing, *Communications of the ACM* (41) 1998, pp. 63–70.
- [107] S. Yoon, J. Kim, An empirical validation of a loyalty model based on expectation disconfirmation, *Journal of Consumer Marketing* (2) 2000, pp. 120–126.

Carlos Flavián holds a Ph.D. in Business Administration and is professor of Marketing in the Faculty of Economics and Business Studies at the University of Zaragoza (Spain). His research in Strategic Marketing and Retailing has been published in several academic journals, such as the *European Journal of Marketing*, *Journal of Consumer Marketing*, *Journal of Strategic Marketing*, *International Review of Retail, Distribution and Consumer Research*, *Journal of Retailing and Consumer Services*, and different books such as *The Current State of Business Disciplines*, *Building Society Through e-Commerce or Contemporary Problems of Inter-*

national Economy. He is in charge of several competitive research projects being developed on the topic of e-marketing.

Miguel Guinalú is assistant professor in the Faculty of Economics and Business Studies (University of Zaragoza, Spain). Previously, he worked as an e-business consultant. His main research line is online consumer behaviour, particularly the analysis of online consumer trust and virtual communities. His work has been presented in national and international conferences, and has been published in several journals, such as *International Journal of Bank Marketing* or *International Journal of Retail &*

Distribution Management, and books, such as *Advances in Electronic Marketing*.

Raquel Gurrea is assistant professor in the Faculty of Economics and Business Studies at the University of Zaragoza (Spain). Her main research lines are online consumer behaviour and the analysis of the advantages and limitations of the Internet in the development of the economic activity. Her work has been published in several journals and has been presented in national and international conferences with high impact such as *International Conference on Recent Advances in Retailing and Services Science*, *Marketing Science Conference* or *European Marketing Academy Conference*.