

RESEARCH PAPER

Available Online at www.jgrcs.info

IMAGE COMPRESSION USING HYBRID TRANSFORM TECHNIQUE

Nikita Bansal^{*1}, Sanjay Kumar Dubey²

^{1,2}Computer Science and Engineering Department, Amity University, Noida, Uttar Pradesh, India
nnikita3@gmail.com^{*1}, skdubey1@amity.edu²

Abstract: Digital images in their uncompressed form require an enormous amount of storage capacity which in turn needs large transmission bandwidth for the transmission over the network. Image compression reduces the storage space of image and also maintains the quality of image. There are various compression techniques available in literature. Discrete Cosine Transform (DCT) is one of the widely used image compression method and the Discrete Wavelet Transform (DWT) is another which provides improvements in the quality of the picture. This research paper proposed a scheme for image compression using DCT and DWT named as hybrid compression technique. DCT has high energy compaction property and often require less computational resources and DWT is multi-resolution transformation. The goal is to achieve higher compression rates with preserving the quality of the reconstructed image.

Keywords- Image compression, DCT, DWT.

INTRODUCTION

Data compression is the method to reduce the redundancies in data so as to decrease data storage requirements and communication costs. Reducing the storage requirement is equivalent to increasing the capacity of the storage medium and hence communication bandwidth [6]. Data is represented as a mixture of information and redundancy. Information is that portion of data which must be preserved permanently in its original form so as to correctly interpret the meaning or the purpose of the data. Redundancy is that portion of the data which can be removed when it is not needed and can be reinserted in order to interpret the exact data when needed. There are two types of compression systems[9]:-

- a. **Lossy Compression System:-** Lossy compression techniques can be used where some of the finer details of the image can be sacrificed for saving a little more bandwidth or storage space [9].
- b. **Lossless compression system:-** Lossless compression system aims at retrieving the decompressed image identical to the original one.

Requirement for image compression system:

An image compression system requires the following two components:

- a. Encoding System
- b. Decoding System

Encoding System takes original image as an input, process it and gives compressed image as an output. While Decoding System takes an compressed image as input and gives the image as output which is more identical to original image. Nowadays, DCT and DWT are the most popular techniques for image compression. Both the techniques are frequency based techniques. Both of the techniques have their own advantages and disadvantages. Like DWT gives better compression ratio without losing more information of image but it need more processing power [14]. While DCT need low processing power but it has block artifacts which means loss of some of the information of the image. Our main goal is to take the advantages of both of the compression techniques and develop a hybrid of DCT and DWT. In recent

times, developing hybrid schemes for effective image compression has gained enormous popularity among the researchers [1]. The aim of this paper is

to achieve better compression ratio by using both of these techniques with less computational resources or overhead, in less time and without much loss of the information in the image.

DISCRETE COSINE TRANSFORM (DCT)

The discrete cosine transform (DCT) separate the image into different parts of varying importance. DCT expresses a sequence of finitely several data points in terms of sum of cosine functions oscillating at different frequencies [2]. In particular, a DCT is a Fourier-related transform similar to the discrete fourier transform (DFT), but using only real numbers [4]. The DCT is a unitary transform, meaning that the inversion can be accomplished [7].

Image Processing by DCT:

Discrete cosine transform (DCT) is widely used in image processing by performing encoding and decoding.

Encoding Technique in DCT:

Steps to encode or compress the image:-

Step1. Firstly the image is broken into $N*N$ blocks of pixels. Here N may be 4, 8 etc.

Step2. Working from top to bottom, left to right, the DCT is applied to each block.

Step3. Every block elements are compressed through quantization means dividing by some specific value.

Step4. This array of compressed blocks that constitute the image is stored in a reduced amount of space. So, first the whole image is divided into small $N*N$ blocks and then DCT is applied on these blocks.

After that for reducing the storage space DCT coefficients are quantized through dividing by some value or by

quantization matrix. So that large value become small and need small size of space. This step is lossy step. If we take small value for quantization then we get the better quality or less MSE (Mean Square Error) but less compression ratio [14]. Block size also affects quality and compression ratio. Simply, higher the block size higher is the compression ratio but with loss of more information and quality.

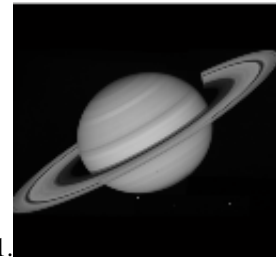

1.

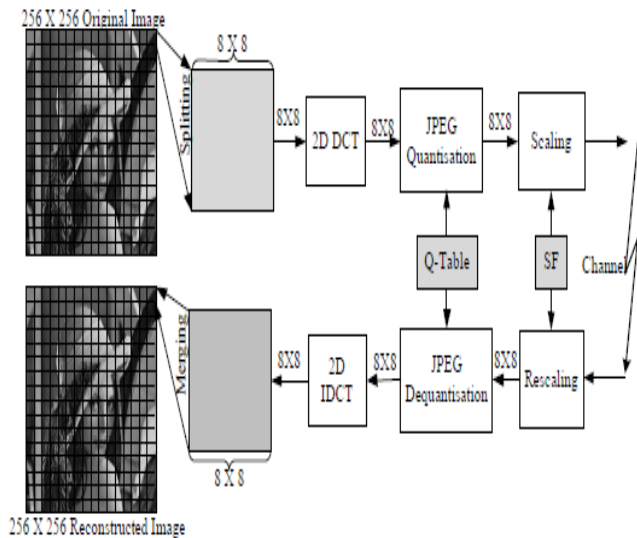

Figure 1. DCT Model [3]

Decoding Technique in DCT:

Decoding system is exact reverse process of encoding. There are four steps for getting the original image not exact but identical to original from compressed image [14].

- Step1. Firstly, load compressed image from disk.
- Step2. Image is then broken into N*N blocks of pixels.
- Step3. Every block is de-quantized by applying reverse process of quantization.
- Step4. Now apply inverse DCT on every block. Then combine these blocks into an image which is identical to the original image.

In the decoding process, N’s value is kept same as it was used in the encoding process. Then de-quantization process is performed by multiplying with quantization value or quantization matrix. This is lossy technique so output image is not exact copy of original image but it is identical to original image. So this process efficiency is measured by compression ratio. Compression ratio is defined by ratio of storage bits of original image and storage bits of compressed image [14].

Loss of information is measured by Mean square Error (MSE) between reconstructed image and original image. If MSE of the reconstructed image to original image is greater, than the information lost is more. As the number of coefficients increases quality of the image decreases whereas compression ratio continues to increase [12].

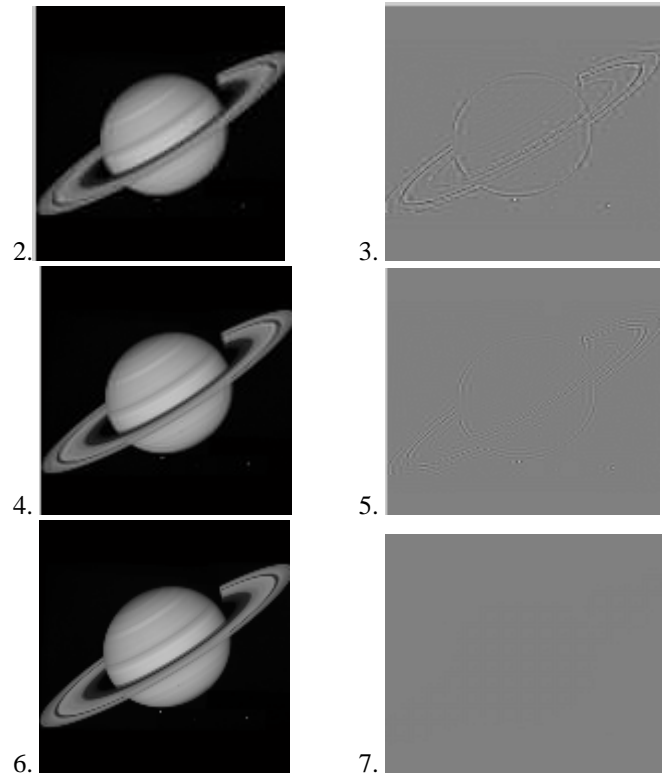

Figure 2. DCT on image 1-Original Image 2-Reconstructed Image DCT(25%) 3-Error Image 4-Reconstructed Image DCT(50%) 5-Error Image 6-Reconstructed Image DCT(100%) 7-Error Image

DISCRETE WAVELET TRANSFORM (DWT)

Research activities in image coding have been focused on the DWT, which has become a standard tool in image compression applications because of their data reduction capability [10,16,17]. In DWT, the entire image is transformed and compressed as a single data object rather than block by block as in a DCT based compression system. Wavelet analysis can be used to divide the information of an image into approximation and detailed sub signal [15]. The approximation sub signal shows the general trend of the pixel value, and three detailed sub signals shows vertical, horizontal and diagonal details. If these details are very small than they can be set to zero without significantly changing the image. The compression ratio increases as the number of zeroes increases. There are two types of filters [15]:-

- a. High pass filter : high frequency information is kept, low frequency information is lost.
- b. Low pass filter : low frequency information is kept, high frequency information is lost.

$$H = 1/\sqrt{2} \begin{pmatrix} 1 & -1 \end{pmatrix} [2]$$

$$L = 1/\sqrt{2} \begin{pmatrix} 1 & 1 \end{pmatrix} [2]$$

So signal is effectively decomposed into two parts, a detailed part (high frequency) and approximation part (low frequency).

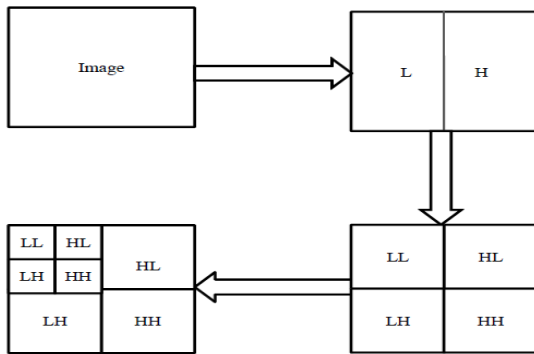

Figure 3. Two levels Wavelet Decomposition applied on an image [13]

- LL= vertical LPF+ horizontal HPF [2]
- HL= horizontal HPF+ vertical LPF [2]
- LH= horizontal LPF+ vertical HPF [2]
- HH= horizontal HPF+ vertical HPF [2]

Image Processing by DWT:

Discrete wavelet transform (DWT) is widely used in image processing by performing encoding and decoding.

Encoding Technique in DWT:

There are six steps for compressing an image with DWT as shown below.

Step1. Firstly, the original image is passed through high pass filter and low pass filter by applying filter on each row.

Step2. Then output of the both image l1 and h1 are combined into t1= [l1 h1].

Step3. Then t1 is down sampled by 2.

Step4. Now, t1 is again passed through high pass filter and low filter by applying filter on each column.

Step5. Output of step4 is supposed to be l2 and h2. Then l2 and h2 are combined into t3= [l2 h2].

Step6. Now t3 is down sampled by 2. This is our compressed image.

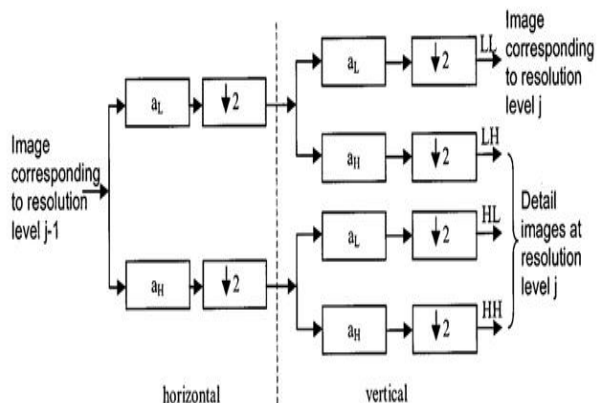

Figure 4. One filter stage in 2-D DWT [5]

In the below figure, an image is shown after applying encoding process. This figure has four blocks. The first upper half block shows the approximation, while second upper half shows the horizontal detail. First lower level block shows the vertical detail and second lower level block shows the diagonal detail.

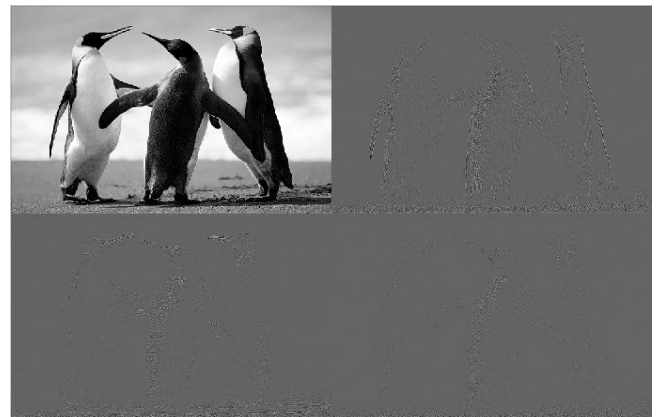

Figure 5. Compressed Image (penguins) [14]

Decoding Technique in DWT:

In DWT, decoding process is not the exact reverse of the encoding process. Steps of the decoding of an image are shown below.

Step1. Extract low pass filter image and high pass filter image from compressed image simply by taking upper half rectangle of matrix.

Step2. Now, both of the images are up sampled by 2.

Step3. Now, the summation of both images is taken into one image called r1.

Step4. Now, again extract low pass filter image and high pass filter image by simply dividing vertically. The first half is low pass filtered image and the second half is high pass filtered image.

Step5. Now, take summation of both of the images and obtained image is called as reconstructed image.



Original Image



DWT-16 quantization levels



DWT-32 quantization levels



Reconstructed image-16 level



Reconstructed image-32 level



Reconstructed image after applying inverse DWT to whole image.

Figure 6. DWT Process On Image [8]

PROPOSED DCT AND DWT TRANSFORM (HYBRID)

In the combined approach, both DCT and DWT are carried out on the image in some sequence one after the other in order to compress the image much more and achieve much higher compression ratios. Compression increases with increase in window size for DCT and decreases with increase in window size for DWT.

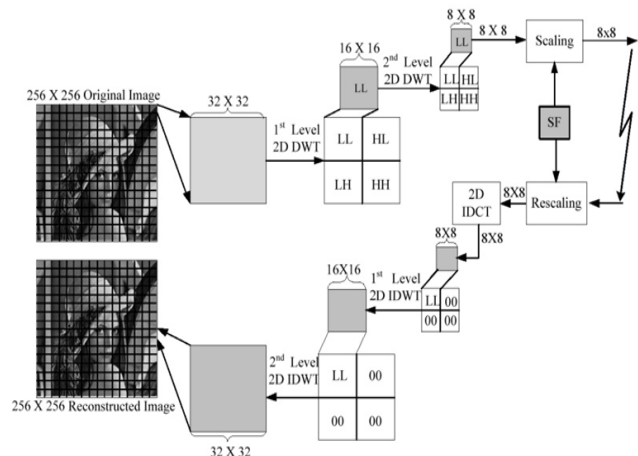

Figure 7. Hybrid Model [11]

Here in this approach, first the image is divided into several blocks of images of size 32*32. Then 2D-DWT 1st level is applied on each block of image which results the image in four sub bands named LL, LH, HH, HL. Then on each sub band 2D-DWT 2nd level is applied again which again result in four different frequencies sub bands. Now first the scaling of these 8*8 blocks of images is done and done rescaling is performed via scaling factor.

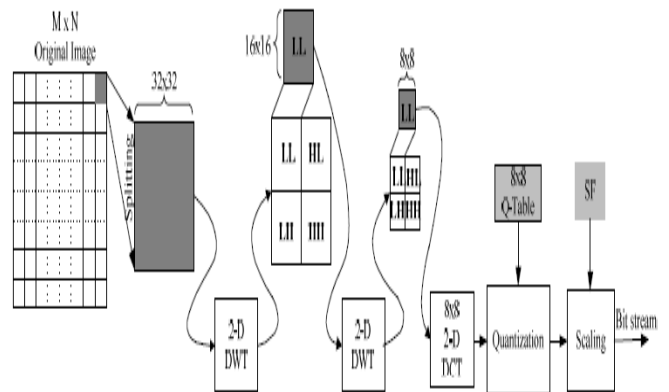

Figure 8. Compression in Hybrid Model [11]

Then on these 8*8 blocks 2D-IDCT is performed followed by 2D-IDWT 1st level on the 8*8 block of images which result in 16*16 blocks of images. Then 2D-IDWT 2nd level is applied which result in 32*32 blocks of images.

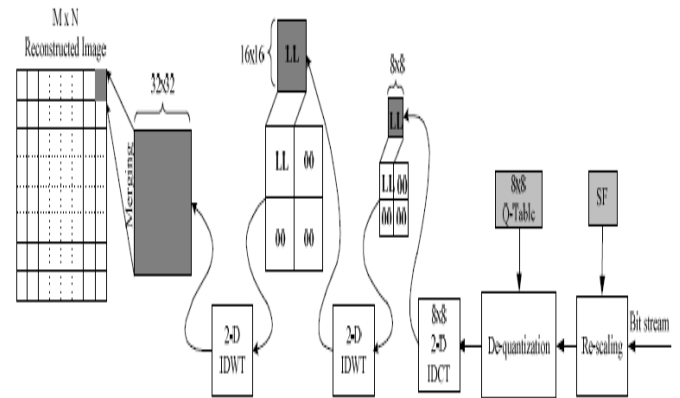

Figure 9. Decompression in Hybrid Model [11]

Then merging is performed in order to retrieve the compressed image. The compressed image occupies less space as compared to the original image as well less then the space occupied by the image when compressed via DCT and via DWT individually.

RESULT AND DISCUSSION

DCT is a technique for image compression which performs efficiently at medium bit rates. Disadvantage of DCT is that only spatial correlation of the pixels is considered and the correlation from the pixels of the neighboring blocks is neglected. Using DCT blocks cannot be decorrelated at their boundaries. DWT provides high compression quality at low bit rates. The use of larger DWT functions or wavelet filters produce blurring near edges in the images. DWT performs better than DCT in that it avoids blocking artifacts which degrade the reconstructed image. However DWT provides lower quality than DCT at low compression rates and

requires longer compression time. Thus a hybrid technique which is a combination of the advantages of both DCT and DWT is proposed which achieves much more compression ratio than that achieved by DCT and DWT.

CONCLUSION

In this paper, hybrid of DCT and DWT for image compression and decompression has been proposed. It is observed that MSE is low and PSNR is high in DWT than DCT based compression. It is concluded that overall performance of hybrid is better than both DCT and DWT on the basis of compression rates. It achieves high compression ratio then both DCT and DWT without much loss of the image information. The image compressed with hybrid technique will require less space for storage and less bandwidth while transmission over the network.

REFERENCES

- [1]. S. Singh, V. Kumar and H. K. Verma, "DWT-DCT hybrid scheme for medical image compression." J Med Eng Technol, vol. 31, no. 2, pp. 109–122, 2007.
- [2]. M. Singh and A. D. Goswami, "Image Compression Technique Using Hybrid Discrete Cosine Transform (DCT) and Discrete Wavelet Transform (DWT) Method", International Journal of Advanced Research in Computer Science and Software Engineering, Vol. 2, Issue 10, 2012.
- [3]. K. Bindu, A. Ganpati and A. K. Sharma, "A Comparative Study Of Image Compression Algorithms", International Journal Of Research In Computer Science, eISSN 2249-8265, Vol. 2, pp. 37-42, 2012.
- [4]. H. Singh and S. Sharma, "Hybrid Image Compression Using DWT, DCT & Huffman Encoding Techniques", International Journal of Emerging Technology and Advanced Engineering, Vol. 2, No. 10, 2012.
- [5]. S. Grgic, M. Grgic, and Branka Zovko-Cihlar, "Performance Analysis of Image Compression Using Wavelets", IEEE Transactions On Industrial Electronics, Vol. 48, No. 3, 2001
- [6]. M. Gupta and A. K. Garg, "Analysis Of Image Compression Algorithm Using DCT ", International Journal of Engineering Research and Applications (IJERA), ISSN: 2248-9622, Vol. 2, Issue 1, pp.515-521, 2012.
- [7]. G. Mandyam, N. Ahmed and N. Magotra, "Lossless Image Compression Using the Discrete Cosine Transform", Journal Of Visual Communication And Image Representation, Vol. 8, No. 1, pp. 21–26, 1997
- [8]. R. M. Haralick, "Statistical and structural approaches to texture", Proc. IEEE, vol. 67, pp. 786-804, 1979.
- [9]. P. Telagarapu, V. J. Naveen, A. L. Prasanthi and G.V. Santhi, "Image Compression Using DCT and Wavelet Transformations", International Journal of Signal Processing, Image Processing and Pattern Recognition, Vol. 4, No. 3, 2011
- [10]. A. S. Lewis and G. Knowles, "Image compression using the 2-D wavelet transform," IEEE Trans. Image Processing, Vol. 1, pp. 244–250, 1992.
- [11]. B. Sriram and S. Thiyagarajan, "Hybrid Transformation Technique For Image Compression", Journal of Theoretical and Applied Information Technology, Vol. 41, No.2, 2012.
- [12]. S. Anitha, "Image Compression Using Discrete Cosine Transform & Discrete Wavelet Transform", International Journal of Scientific & Engineering Research, Vol. 2, No. 8, 2011.
- [13]. T. Singh, S. Chopra, H. Kaur and A. Kaur, "Image Compression Using Wavelet and Wavelet Packet Transformation", International Journal of Computer Science and Telecommunications, I S S N : 0 9 7 6 - 8 4 9 1, Vol. 1, Issue 1, 2010
- [14]. A. K. Katharotiya, S. Patel and M. Goyani, "Comparative Analysis between DCT & DWT Techniques of Image Compression", Journal of Information Engineering and Applications, Vol 1, No.2, 2011.
- [15]. R. C. Gonzalez and R. E. Woods.(1992), Digital Image Processing(2nd edition), NJ:Prentice Hall.
- [16]. M. L. Hilton, "Compressing still and moving images with wavelets," Multimedia Syst., Vol. 2, no. 3, pp. 218–227, 1994.
- [17]. M. Antonini, M. Barl, P. Mathieu and I. Daubechies, "Image coding using the wavelet transform," IEEE Trans. Image Processing, Vol. 1, pp. 205–220, 1992.

Short Bio Data for the Author



Nikita Bansal is pursuing her M.tech in Computer Science and Engineering from Amity university, Noida,(U.P.) India. Her research area includes Digital Image Processing, Cryptography and Software Engineering.



Mr. Sanjay Kumar Dubey is Assistant Professor and Proctor in Amity University, Noida (U.P.), India. He has published more than 40 papers in National/International Journals including ACM. He has presented 14 research papers at various National/International conferences. He also wrote two books Basic Computer Engineering and Object-Oriented Programming.