

# Image correlation to evaluate influence of hygrothermal loading on wood

**Citation for published version (APA):**

Gauvin, C. A. F., Jullien, D., & Gril, J. (2013). *Image correlation to evaluate influence of hygrothermal loading on wood*.

**Document status and date:**

Published: 01/01/2013

**Document Version:**

Accepted manuscript including changes made at the peer-review stage

**Please check the document version of this publication:**

- A submitted manuscript is the version of the article upon submission and before peer-review. There can be important differences between the submitted version and the official published version of record. People interested in the research are advised to contact the author for the final version of the publication, or visit the DOI to the publisher's website.
- The final author version and the galley proof are versions of the publication after peer review.
- The final published version features the final layout of the paper including the volume, issue and page numbers.

[Link to publication](#)

**General rights**

Copyright and moral rights for the publications made accessible in the public portal are retained by the authors and/or other copyright owners and it is a condition of accessing publications that users recognise and abide by the legal requirements associated with these rights.

- Users may download and print one copy of any publication from the public portal for the purpose of private study or research.
- You may not further distribute the material or use it for any profit-making activity or commercial gain
- You may freely distribute the URL identifying the publication in the public portal.

If the publication is distributed under the terms of Article 25fa of the Dutch Copyright Act, indicated by the "Taverne" license above, please follow below link for the End User Agreement:

[www.tue.nl/taverne](http://www.tue.nl/taverne)

**Take down policy**

If you believe that this document breaches copyright please contact us at:

[openaccess@tue.nl](mailto:openaccess@tue.nl)

providing details and we will investigate your claim.

# IMAGE CORRELATION TO EVALUATE INFLUENCE OF HYGROTHERMAL LOADING ON WOOD

C. Gauvin, D. Jullien and J. Gril

Laboratory of Mechanical and Civil Engineering, University of Montpellier 2

Place Eugène Bataillon, 34095 Montpellier Cedex 5, France

cecilia.gauvin@univ-montp2.fr, delphine.jullien-pierre@univ-montp2.fr, joseph.gril@univ-montp2.fr

## 1. INTRODUCTION

Many wooden objects from cultural heritage consist in wooden panels, painted on one face. Nowadays some of these panels show permanent cupping, micro-cracks of the painted layer, cracks of the painted support itself...

Different physical and mechanical phenomena are at the origin of these damages: wood is a hygroscopic material (its dimensions vary with humidity), it is highly anisotropic, the painted layer on one face has properties of permeability different from raw wood of the back face, a rigid frame may have locked the strains of the panel...

The mechanical engineer may contribute to the conservation issue by giving expertise on the preventive conservation of a given artwork or collection, such as acceptable micro-climatic conditions, the risk associated to the movement of the object, the opportunity to modify the frame type.

A numerical modelling of painted panel has been developed by LMGCE these last years. It is based on in-situ data collected on instrumented panels. We now need to collect a set of data concerning both the behaviour of the material itself and the reaction of a panel constituted by this well-identified material and submitted to controlled hygrothermal fluctuations. Finally, experimentations on our self-made panels combined to numerical simulations of these panels in real situations of hygrothermal fluctuations will allow us to test specific situations and give elements of answer to conservators and restorers to guide them in their interventions.

For this purpose, data image correlation is used to evaluate the strain field of the section of a wood piece submitted to variations of relative humidity.

## 2. MATERIEL AND METHOD

The species used was poplar (*Populus Alba*). Two kinds of board were used: a flatsawn board or a quartersawn board (Fig. 1). The ring orientation can be seen on the specimen section, our work is based on the deformation of these rings.

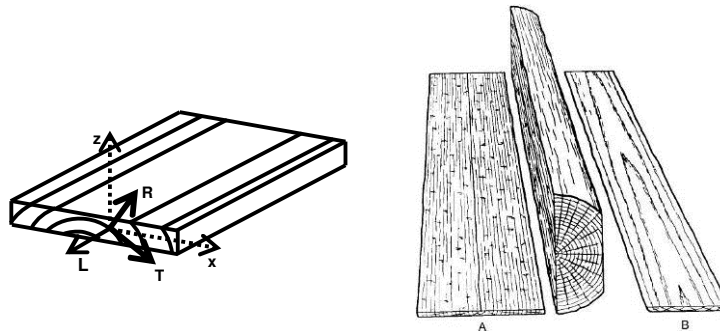
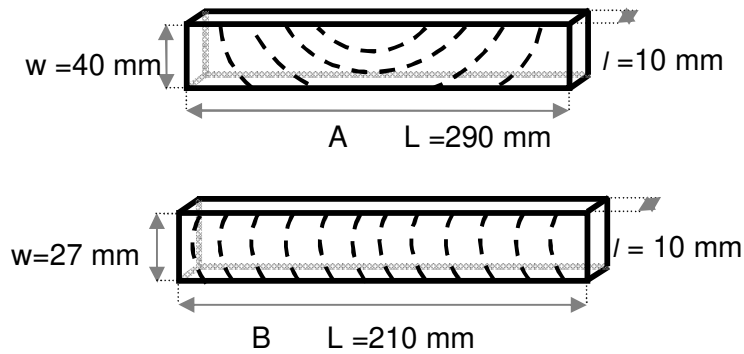

Figure 1 – Wood panel, orthotropic orientation  
Quartersawn (A) and flatsawn (B) boards cut from a log

Dimensions of specimen are 290x6x40 mm for flatsawn and 210x10x27 mm for quartersawn (Fig.2). We applied rubber coating on different faces to control the hydration orientation of our samples. Here, we will focus on situations involving diffusion along the longitudinal direction of the samples.



**Figure 2 – Specimen sizes. (A) flatsawn. (B) Quartersawn**

A climatic chamber was used to control temperature and relative humidity at  $\pm 3$  °C/RH.

### 3. HYGROTHERMAL LOADING

#### 3.1 Humidity cycles

Permanent cupping is observed in most of panel paintings. Hygroscopic ageing is one of the possible mechanisms to explain this permanent cupping.

To test this hypothesis, eleven humidity cycles were imposed [1] between 40% and 90% RH, at 50 °C to a set of samples (Fig.3). The hygroscopic response was simulated using *Transpore* [2], a wood drying simulator, which indicated that the equilibrium moisture content of our 10 mm width specimens (longitudinal diffusion orientation) was reached with a 15 hours plateau.

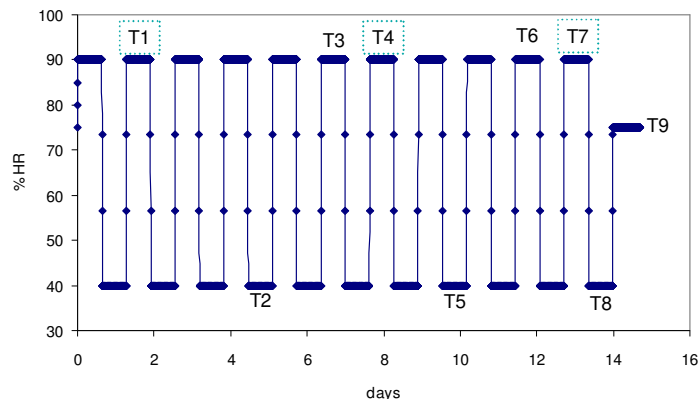

**Figure 3 – Relative humidity cycles**

Pictures were taken at different time (T1...T9) during cycles, at the end of plateau to be sure that samples are at the equilibrium moisture content. Using Vic-2D 2009 ©, we calculated the corresponding strain fields by image correlation. The reference picture was at equilibrium state of 75%RH, at 50°C before ageing cycles.

#### 3.2 Strain evolution at equilibrium moisture content

The 90%RH flatsawn data (Fig.4) show that the deformations  $\epsilon_{xx}$  and  $\epsilon_{yy}$  decreased with cycles. The hygroscopic ageing induced a reduction of swelling strain.

The same result were found with the quartersawn sample (Fig.5).

This decrease of deformation shows that the samples loose hygroscopicity. Humidity cycles may induce a chemical ageing that corresponds to a process of extenuation of the cell wall polarity [1].

$\epsilon_{xx}$  and  $\epsilon_{yy}$  include radial and tangential strain components. The higher deformation of  $\epsilon_{xx}$  located between 3000 and 4000 pixels on X axis (Fig. 4) may be explained by the concordance of X and Tangential directions in this area.

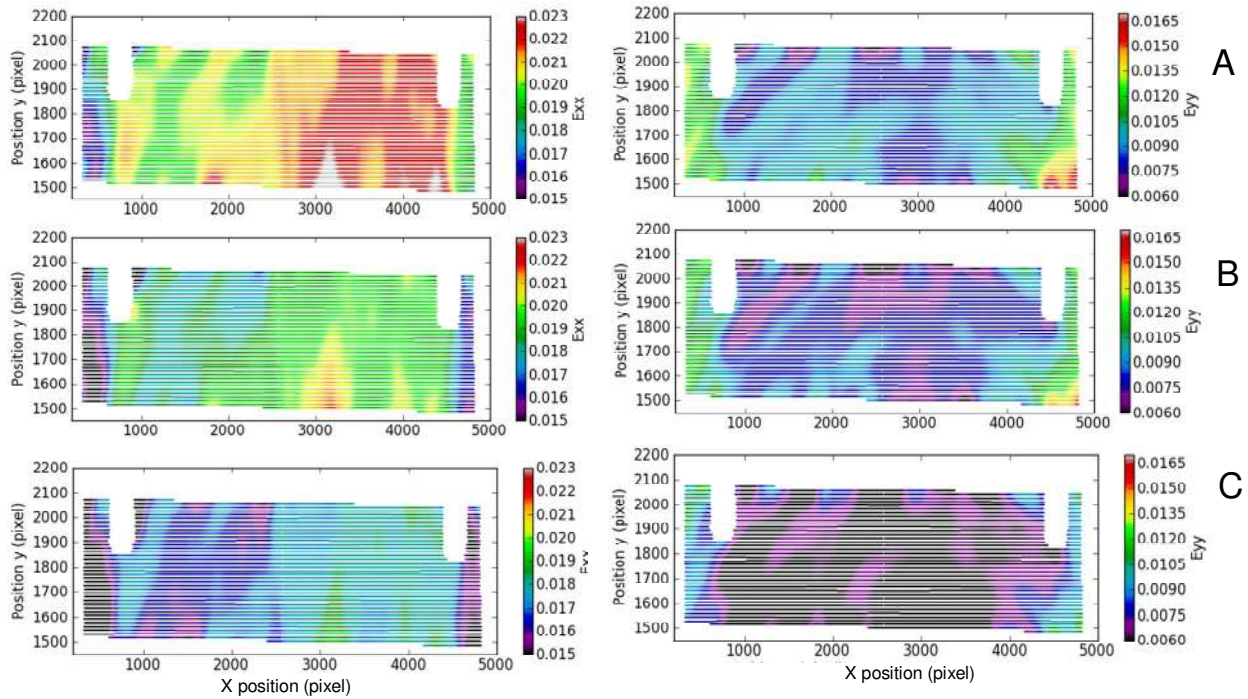

Hygrothermal loading  
 Strain evolution of poplar flatsawn sample at 90% RH  
 (A) At T1 (cf. Figure 3)      (B) At T4      (C) At T7

**Figure 4 - Strain evolution of a flatsawn sample at 90%RH**

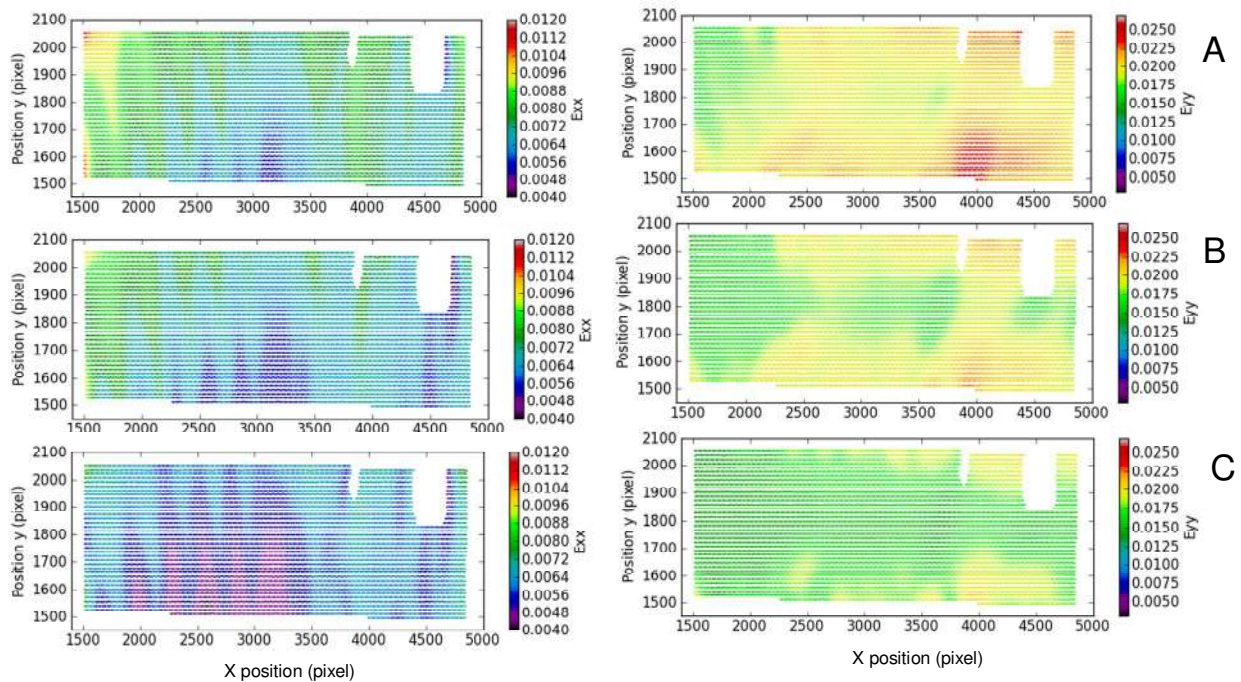

Hygrothermal loading  
 Strain evolution of quartersawn poplar sample at 90% RH  
 (A) At T1 (cf. Figure 4)      (B) At T4      (C) At T7

**Figure 5 - Strain evolution of a quartersawn sample at 90%RH**

#### 4. WOOD RING INFLUENCE ON STRAIN DISTRIBUTION

Let us focus on year ring influence on deformation. We applied a rubber coating on 4 faces: for the flatsawn sample, the tangential diffusion is possible; and for the quartersawn sample, the radial diffusion is possible. Then we put them at 90%RH, 20°C until equilibrium.

We can see on Figures 6 and 7 that:

- The intensity of strain matches with the ring shape (a)&(b);

- $\epsilon_{xx}$ , which corresponds to tangential strain, does not change much with radial position.
- $\epsilon_{yy}$ , which corresponds to radial strain, varies inside rings: swelling is clearly higher in latewood than in earlywood (c).

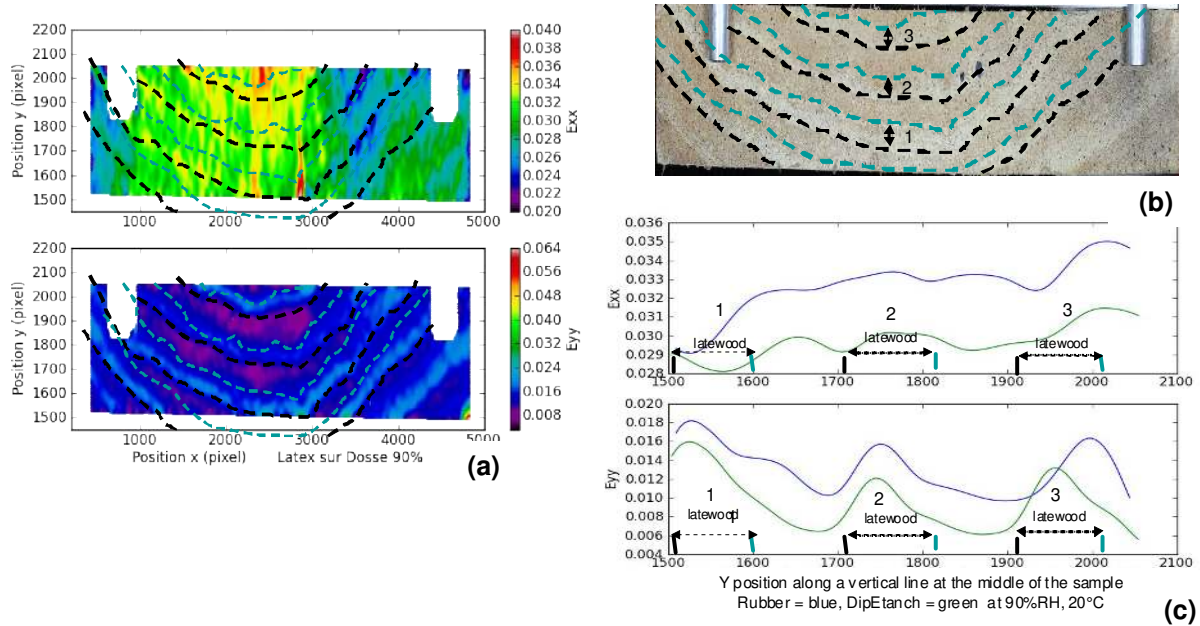

Figure 6 – Strain distribution on a flatsawn sample at 90%RH

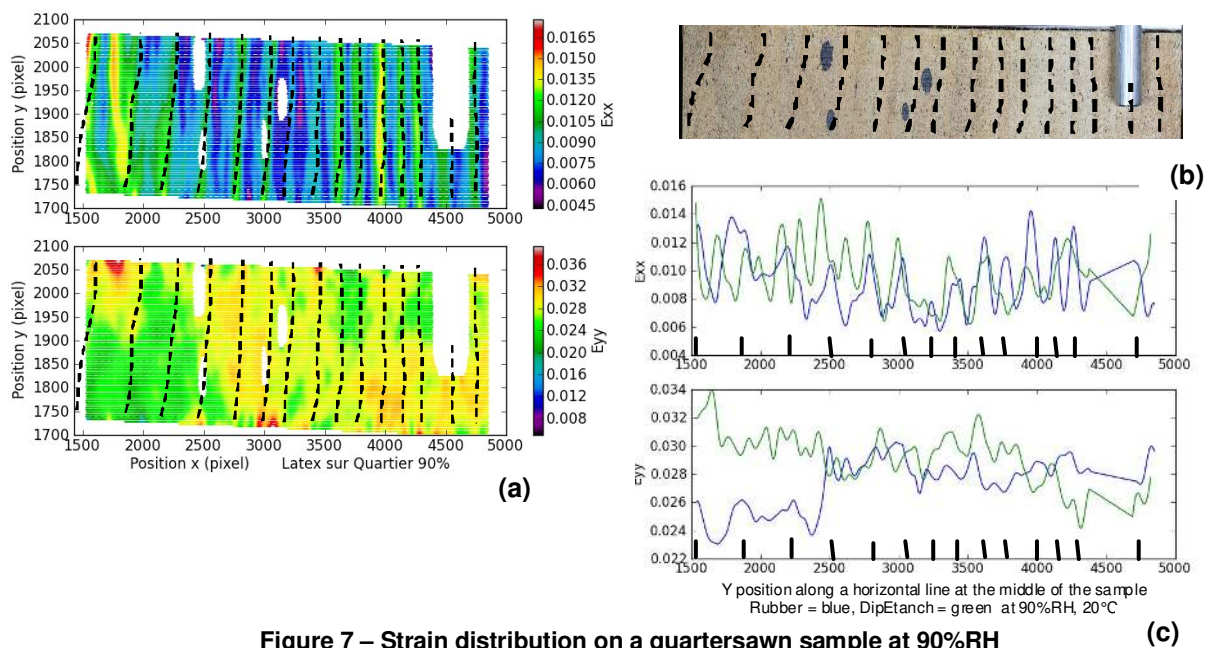

Figure 7 – Strain distribution on a quartersawn sample at 90%RH

## 5. CONCLUSION

We have measured the dimensional variations of wood samples submitted to hygrothermal cycles by image correlation. The results have evidenced a loss of hygroscopicity of wood with cycles. This phenomenon is called ageing. The strain fields obtained by image correlation are in very good agreement with the anisotropic behaviour expected after macroscopic observations such as the position and the orientation of growth rings. This method allows to evidence the higher swelling of latewood compared to earlywood.

## 6. REFERENCES

1. Esteban, L.G., Gril, J., De Palacios De Palacios, P. and Guindeo Casasús, A. (2005) Reduction of wood hygroscopicity and associated dimensional response by repeated humidity cycles. *Annals of Forest Sciences, Volume 62, Number 3, 275 – 284*
2. Perre, P. (2007) Fundamentals of Wood Drying. *European COST. A.R.BO.LOR*