

Received May 31, 2019, accepted June 16, 2019, date of publication June 24, 2019, date of current version July 12, 2019.

Digital Object Identifier 10.1109/ACCESS.2019.2924806

Impact of Channel Disturbances on Current Narrowband Power Line Communications and Lessons to Be Learnt for the Future Technologies

ASIER LLANO¹, (Member, IEEE), DAVID DE LA VEGA², (Member, IEEE),
ITZIAR ANGULO², (Member, IEEE), AND LAURA MARRON¹

¹Department of R&D, ZIV Automation, 48170 Zamudio, Spain

²Bilbao Faculty of Engineering, University of the Basque Country, 48013 Bilbao, Spain

Corresponding author: Asier Llano (asier.llano@zivautomation.com)

This work was supported by the Basque Government under Grant Elkartek KK-2018/00037.

ABSTRACT The electricity network is a complex communication medium with properties that depend on both the topology of the grid and the usage pattern of the connected devices. These devices generate channel disturbances during normal operation, which need to be overcome by power line communications (PLC) transmission technologies for ensuring communication. This paper analyzes the influence of the channel disturbances on the performance of the physical layer of the main narrowband PLC technologies approved by international communication organisms and currently deployed in Europe: PowerLine Intelligent Metering Evolution (PRIME) 1.3.6, PRIME 1.4 and G3-PLC. The methodology of this paper applies a standardized test method, metrics and a set of representative channel disturbances defined by the European Telecommunications Standards Institute (ETSI). Moreover, noise recordings from field measurements in an environment equipped with distributed energy resources (DER) complete the subset of the types of noise used in the study. This paper develops a replicable, fully automated, and cost optimized test scenario, based on an innovative Virtual PLC Laboratory, which provides a replicable and automated test process, where a wide range of channel disturbances can be accurately replicated, and the performance of the PLC technologies can be compared under the same conditions. The results of this paper provide important conclusions to be applied in the development of future PLC technologies.

INDEX TERMS Channel capacity, communication channels, communications technology, communication networks, decoding, electricity supply industry, narrowband, network function virtualization, noise measurement, OFDM modulation, physical layer, smart devices, smart grids, telecommunication network reliability.

I. INTRODUCTION

Smart Grids can efficiently integrate the activity and needs of all the connected users. Data management and correlation can ensure a sustainable and efficient energy system, with controlled losses, high levels of quality and energy efficiency.

Power Line Communications (PLC) technologies are used to communicate signals through the power line, being the key to the automation level of electricity distribution. Low Voltage (LV) narrowband PLC (from 3 to 500 kHz) is the most extended solution for the communication in the Advanced Metering Infrastructure (AMI) systems according to [1].

The associate editor coordinating the review of this manuscript and approving it for publication was Naofal Aldahir.

A study about the smart grid projects in Europe evaluates the most developed technological solutions for LV metering applications. These studies select ZigBee and narrowband PLC technology as the most popular technologies for AMI systems communication [2]. Therefore, narrowband PLC is a solution extensively adopted by utilities to create a communication network for the electricity Smart Meters, as it does not require a dedicated communication medium deployment and its deployment and operational costs are low compared to other technologies.

The drawback of this solution is that the electricity network is very variable when considered as a communication medium, as the transfer function and noise sources depend on the consumption patterns of the electricity users.

The variability of the medium and the market requirements for constant evolution motivate continuous technology improvement and validation.

Evaluating the 2 to 150 kHz frequency range from the electromagnetic compatibility (EMC) point of view, recent studies such as [3] state that EMC standardization is incomplete. EMC standards are used in all kind of electrical, electronic or telecommunications equipment, trying to prevent the existence of interferences in the different frequency bands. There is an actual need for standard development in the 2 to 150 kHz frequency range as described in [4]. This emission level standardization gap opens a list of research challenges regarding channel disturbances influence on PLC.

In this context, standardization committees are demanding results from studies, mainly within the 2 to 150 kHz frequency range [5]. The importance of this topic is demonstrated by the creation of specific working groups in the main international associations and standardization organizations to address this topic, with the aim of providing regulatory results. Although there are some ongoing investigations, there is still limited knowledge. As a representative example, the European Committee for Electrotechnical Standardization (CENELEC) published in October 2015 the 3rd edition of the report “Electromagnetic Interference between Electrical Equipment / Systems in the Frequency Range below 150 kHz”. In this report, CENELEC highlights the lack of specific regulation regarding compatibility and emission levels [6]. Other working groups addressing the impact of disturbances within the 2 to 150 kHz range are the International Council of Large Electric Systems (CIGRE) and International Conference on Electricity Distribution (CIRED) joint working group C4.24 [7], IEEE P1250 (Power and Energy Society) group [8] and IEEE Electromagnetic Compatibility Society TC7 group [9], which has worked in coordination with International Electrotechnical Commission (IEC) Subcommittee (SC) 77A [10]. Apart from that, standardization organisms have focused their efforts on documenting disturbances characterization. In this context, there are different documents containing disturbances collections published by CENELEC [6], the European Telecommunications Standards Institute (ETSI) [11] and IEEE [12].

Under this EMC standardization gap, channel disturbances and non-intentional emissions need to be overcome during PLC signal propagation over the distribution network. There are different studies about channel disturbances and their influence in narrowband PLC communication systems.

Some studies are based on an analytic approach [13]–[15]. These studies do not cover complete communication standards. Mathur *et al.* [13], [14] thoroughly analyze binary phase-shift keying (BPSK) and quadrature phase-shift keying (QPSK) modulated signals under different background and impulsive noise models. Dubey and Mallik [15] study a BPSK system equipped with amplify-and-forward relays.

Other papers focus on generic PLC communication systems [16]–[18]. Liu *et al.* [16] cover channel phase distortion

influence on a differential code shift keying PLC system. Mitra and Lampe [17] use a partitioned Markov chain to analyze the performance of convolutional encoding of narrowband systems. Ndo *et al.* [18] investigate the performance of offset quadrature amplitude modulation in impulsive environments.

Several articles study PowerLine Intelligent Metering Evolution (PRIME) performance based on its statistical performance on field installations [19]–[22] covering issues observed after deployment. Sendin *et al.* [19] describe Iberdrola Smart Grid deployment network architecture and performance. Reference [20] proposes ways to overcome harsher noise situations and [21] evaluates alternatives for PLC signal injection. Reference [22] develops guidelines of PLC network deployment based on real field knowledge.

PLC communication performance can also be evaluated at upper layers level [23]–[25]. Slacik *et al.* [23] focus on the transmission quality and speed, González-Sotres *et al.* [24] measure the number of registered nodes and the time to read all meters, Sanz *et al.* [25] evaluate the number of errors in the received frames. Key performance indicators selected in these cases are upper layer oriented, not focused on physical layer performance. Some of the field studies mentioned above [19]–[22] were also oriented to upper layers performance.

Focusing on G3-PLC and PRIME technologies, some address PRIME [24] or G3-PLC [25] at independent studies whereas others cover both technologies in the same analysis [23]. Hoch [26] compare the physical layers of both PRIME and G3-PLC. Matanza *et al.* [27] extend this work including simulations with different impulsive noise environments taken from real measurements. However, the available studies focus on PRIME in its 1.3.6 version and not coherent modulation schemes for G3-PLC, i.e., they do not cover the latest evolutions of these standards.

There is a lack of PLC PRIME studies in its latest 1.4 version. Some real-field tests [28], [29] are published covering PRIME 1.4 band extension from 150 kHz to 500 kHz. Fernandez *et al.* [28] use higher frequencies as an overlay network, while Arechalde *et al.* [29] verify physical layer performance through field tests.

Most of the published literature is based on simulations, using platforms that do not declare to use protocol stacks certified by G3-PLC or PRIME. For example, the study from Matanza *et al.* [27] is based on a Matlab numerical model. Van Laere *et al.* [30] describe a G3-PLC physical layer software simulator. Upadhyay *et al.* [31] offer comparative simulation results of narrowband PLC physical layers under Additive White Gaussian Noise (AWGN) and narrowband interferers. There are two exceptions, [25] and [32]. Sanz *et al.* [25] present a network simulator which uses a simplified Matlab model as physical layer with G3-PLC certified upper layers. It focuses on the solution architecture not presenting detailed performance results. The same research team of the current manuscript presented a preliminary work evaluating PRIME 1.3.6 physical performance [32], which was based on

a PRIME certified modem and it used synthetic disturbances and channel conditions.

There are also certain laboratory experimental investigations whose setups and noise sources are not standard. Mölders *et al.* [33] evaluate G3-PLC topology changes under photovoltaic inverter noise emissions whereas Mlynek *et al.* [34] evaluate upper layers data rates.

The standardized laboratory setup from ETSI TS 103 909 v1.1.1 [11] is used in Hallak *et al.* [35] to analyze the reached notch depth of G3-PLC devices. As this study analyzes parameters of the transmitted signal, ETSI [11] noises and metrics are not required.

A high variety of noise sources is used for performance measurements. Matanza *et al.* [36] evaluate PRIME performance under background and impulsive noises. Hoch [26] compares PRIME and G3-PLC performance using noise mathematical models. Kim *et al.* [37] measure different PLC systems under AWGN, periodic impulsive noise, and narrowband interferers. Robson *et al.* [38] use realistic line and transformer models.

The present work contributes with relevant results to the available research regarding the impact of disturbances on narrowband PLC, as detailed in the following section.

II. OBJECTIVES AND SCOPE

The main goal of this paper is the characterization of the influence of real-world AC mains channel disturbances on the physical layer of different open standards for LV narrowband Power Line Communication, in order to derive conclusions to be applied in future PLC technologies.

The analyzed narrowband PLC technologies are approved by international organisms and currently deployed in Europe in CENELEC-A band (9 to 95 kHz): PRIME 1.3.6, PRIME 1.4 (defined by PRIME Alliance in [39]–[42] and standardized by ITU-T [43]) and G3-PLC (standardized by ITU-T [44]).

Evaluating the influence of real-world conditions on the above-mentioned standards requires the identification, characterization and selection of multiple representative channel disturbances, which must be clearly defined, repeatable and supported by the scientific community. The selection of representative channel disturbances is described in Section III.

The procedure to characterize the performance of narrowband PLC technologies under different channel disturbances is based on a test method selection and a test setup definition. The test method selected due to its replicability and standardization level is included in ETSI TS 103 909 V1.1.1 [11], where test techniques to determine the performance of narrowband PLC technologies using any modulation in the frequency range 9 kHz to 500 kHz are described. The test scenario defined in [11] is configured within the Virtual PLC Lab developed by the authors and described in [45]. This way, the performance of these technologies is compared thoroughly under the same conditions, following a standardized test method and metrics defined by ETSI standardization organization.

The impact of the evaluated set of disturbances on each PLC transmission configuration is measured through test metrics. The test metrics selected for these tests are also defined in ETSI TS 103 909 V1.1.1 [11]. These metrics measure the link budget and effective data rate of the physical layer communications. A complete description of the followed test method and selected test metrics is included in Section IV.

The results of the calculated test metrics are presented in Section V and analyzed in detail in Section VI. Finally, the drawing of conclusions and the identification of the future working lines are found in Section VII. As the results of this study lead to the optimization of communication algorithms, new implementations in future PLC standards are derived.

In summary, the main contributions and novelties of this work are:

(a) Novel physical configuration comparison including all CENELEC-A modes available for G3-PLC and PRIME technologies. As a significant contribution, it covers PRIME standard in its recent 1.4 version and G3-PLC coherent modes.

(b) It follows a standard procedure, test setup and metrics. ETSI TS 103 909 v1.1.1 [11] is followed as a reproducible and standard environment to determine the performance of narrowband PLC technologies under realistic channel conditions.

(c) Multiple technologies are evaluated under the same circumstances in a repeatable and controlled environment.

(d) Performance is measured with a complete implementation of physical layer modems whose technology is certified by G3-PLC and PRIME Alliances.

(e) This work offers performance data of PLC receivers under a wide set of standard and controlled noise patterns. It includes 31 standard perturbation waveforms from ETSI TS 103 909 v1.1.1 [11], along with a selection of field disturbances from Distributed Energy Resources (DER).

III. REPRESENTATIVE CHANNEL DISTURBANCES

As introduced above, in the present work the impact of a set of disturbances on PLC performance is measured through standardized test metrics. Therefore, a set of representative channel disturbances to be found in the LV distribution grid is selected:

- 1) ETSI TS 103 909 v1.1.1 [11] standard addresses test techniques that can be used to evaluate the performance of narrowband PLC technologies under realistic channel conditions. This standard defines a real-world noise collection that aims to represent the most challenging situations for PLC communications. This disturbances collection is well defined, repeatable and supported by the scientific community.
- 2) The set of noises described in [11] is completed with a selection of disturbances generated by DER, which have demonstrated to be critical noise sources for PLC [46], [47].

In addition to these noise sources, controlled AWGN is used as part of the disturbances collection for the

characterization of the PLC performance. It is included as a reference noise with well-known properties whose results can be compared to other kind of noises.

The selected set of noises does not include colored background noise, which is commonly present in the PLC network, due to the fact that this study is focused in the most challenging types of noises. As described in section 4.7 of [11], the colored background noise will be the dominant effect only when the already described ones are not present.

A. ETSI TS 103 909 NOISE COLLECTION

An examination of real-world environments reveals that the numerous devices connected to the AC mains generate a wide variety of noise. The ETSI TS 103 909 document [11] describes 31 noise waveforms grouped into four types. These test noises are based on real-world characteristics and aim to represent the 95th to 99th percentile of noise amplitude levels that can be found in real deployments (as defined in section 4.1 of ETSI document [11]).

- 1) **Tonal noise (25 waveforms):** Noise sources modeled come in the form of off-line AC switch-mode power converters. Most modern electronic products use this type of power converter. The fundamental switching frequency is commonly within the range of 25 kHz to 150 kHz. Regarding the tonal noise representation, the ETSI document selects 25 waveforms with fundamental frequencies from 26 kHz through 146 kHz (in 5 kHz increments). These conducted emissions are rich in both even and odd harmonics of the fundamental; the amplitude of the harmonics decreases with frequency. An example of this type of noise (the lowest-frequency test tone of 26 kHz) is shown in Fig. 1.
- 2) **Periodic impulse noise (1 waveform):** Noise sources are generated by a triode for alternating current controlled lamp dimmer. This type of device disconnects its load from the AC mains for a fraction of each half AC cycle, and then reconnects the load to the mains for the remainder of that half cycle. This reconnection of the load produces a large voltage spike on the mains. The ETSI document selects one waveform representing this effect.
- 3) **Random impulse noise (1 waveform):** Series-wound AC motors are a very common source of this type of

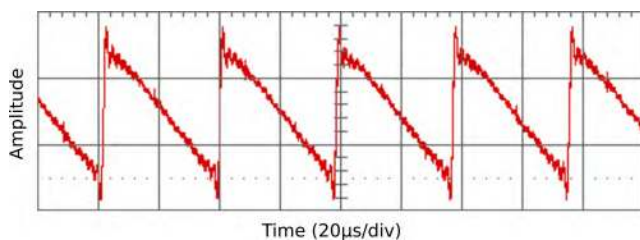

FIGURE 1. Tonal noise 26 kHz 710 mV_{pp} waveform. (Source: [11]).

noise. These motors have brushes that arc when passing between commutator segments. The arcing produces impulses on the mains that are much smaller in amplitude than those generated by periodic-impulse noise sources, but at higher frequencies. The ETSI document selects one waveform representing this effect.

- 4) **Intentional communicator noise (4 waveforms):** The waveforms defined are comprised of 1 waveform of a device complying with the ISO/IEC 14908-3 standard [48] and 3 waveforms of power line intercoms (or baby monitors), which transmit Frequency Modulated signals at 160 kHz, 250 kHz and 400 kHz.

B. NON-INTENTIONAL EMISSIONS FROM DER

The analysis of the effects of noise has been completed with a second source of different types of noise, recorded in some field trials carried out close to several DER at CEDER-CIEMAT facilities, a Spanish center for research, development and promotion of renewable energies [49]. A compilation of these noise recordings is available at [46], [50]. The deployed infrastructure in CEDER-CIEMAT matches the definition of a microgrid: multiple distributed generation and storage points connected to the final consumers (in this case, office buildings and machinery) through a LV distribution grid. Distributed generation (DG) is a key element in the electricity networks of the future, where the consumer becomes prosumer, and the roles of the involved agents are not so clearly delimited. In this context, the study of the influence of channel disturbances on LV narrowband PLC must cover DER sources as representative channel disturbances in the near future.

The facilities at CEDER-CIEMAT are equipped with an AMI, composed of a high number of Smart Meters, located close to each DER, storage device, group of offices or machinery pavilion, all of them connected by narrowband PLC communications [46], [47]. Therefore, it is a good scenario to analyze the impact of different types of noise on the communications of the AMI under normal operation.

The study conducted in this paper is completed with a set of six types of noise selected from these field trials [50], in order to evaluate the impact of the noise generated by the normal operation of DER in PLC performance, as an extension to the set of noises collected by ETSI [11].

The noises selected from the field trials at CEDER-CIEMAT [50] were recorded in the following scenarios:

- 1) A rooftop 12 kW photovoltaic system connected to the network through an INGECON SUN 10 three-phase inverter, both in normal operation and during the power-on process of the inverter (disturbances labeled as *der04* and *der06*). Fig. 2 shows the spectrogram of *der04* disturbance generated by the inverter, in normal operation.
- 2) An 8.28 kW photovoltaic system connected to the network through an INGECON SUN 10 three-phase inverter (disturbances labeled as *der34* and *der36*).

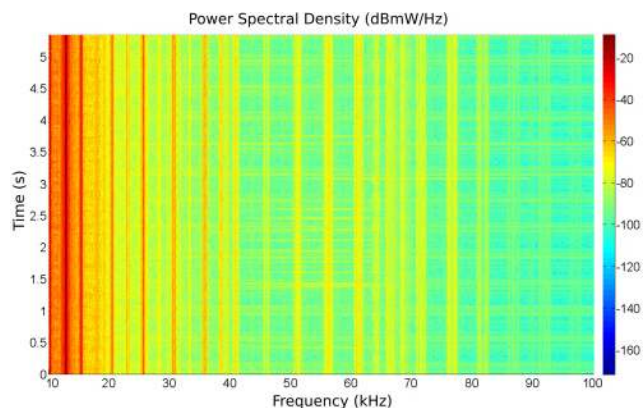

FIGURE 2. Spectrogram of *der04* disturbance generated by the inverter, in normal operation (Source: [45]).

- 3) A combination of an AOC 50 kW wind turbine and a Bornay 3 kW wind turbine connected to a distributed storage system. The storage system includes a lean-acid batteries unit of 240 Vdc in standby and charging status (disturbances labeled as *der50* and *der51*).

IV. METHODOLOGY

The methodology defined for this research is oriented to a high level of replicability and standardization. The goal is that this methodology allows technologies performance comparison under exactly the same conditions.

The PLC performance tests require a setup where a transmitter, a channel and a receiver are connected. The transmitter requires a complete implementation of a communications modem, where each modulation technique for the PLC communication under test will be used. The system will include the impact of each of the noises and disturbances under test. The receiver will try to decode the frames generated in the transmitter, under each transmitter condition and noise pattern.

Both the test method and the metrics selected for the study are defined and standardized by ETSI. In this context, the channel configurations with the selected noise disturbances are applied.

The physical configuration of the modulation techniques of the technologies under test is required as part of the performance analysis.

The test scenario is based on the Virtual PLC Lab [45], in order to be replicable, fully automated and cost optimized. In this test scenario, the ETSI test procedures are implemented so that they can be executed by independent test laboratories. Therefore, the Virtual PLC Lab is the virtual laboratory where the ETSI tests are executed, and laboratory results can be evaluated.

A. TEST SCENARIO BASED ON VIRTUAL PLC LAB

Extensive laboratory testing for technology improvement is required due to the variable disturbances of the

communication channel, and the market requirements for continuous evolution.

A typical laboratory setup for PLC technology testing involves several analogue elements and requires long and expensive testing tasks. These procedures can greatly benefit from the virtualization concept to increase the testing speed and repeatability, and to reduce the operation and maintenance costs. The PLC testing complexity reduction should be focused on the following factors:

- 1) Time-consuming testing process: Measuring with precision Frame Error Rate (FER) values for different types of noise and channel conditions requires transmitting and receiving thousands of frames.
- 2) Test replication challenge: The repeatability of the results is a major concern, as laboratory setups are exposed to multiple variations of the measurement conditions.
- 3) Development costs: The Digital Signal Processing (DSP) algorithm implementation in real products requires integration effort in order to fit in the specific and limited processing capabilities of production hardware.
- 4) Automation level: Efforts must be oriented to reduce manual operation and to gain automation without increasing maintenance costs.

In order to overcome these challenges, Virtual PLC Lab was designed and implemented as a system that replicates all the analogue elements of a PLC laboratory in digital technology. To avoid any deviation of the results because of the digital quantization, IEEE 754 double precision floating point numbers are used. Moreover, some non-linear effects that are relevant for the results are implemented, like reception saturation and ADC quantization. More details of the Virtual PLC Lab implementation can be found in [45].

This tool is able to run, in a single computer, multiple Virtual PLC modems connected through a virtual digital medium with configurable characteristics, such as attenuation, noise patterns and transfer function models.

The validity of the results provided by this virtualized laboratory was checked for certain G3-PLC configurations by comparing the results with the ones provided by independent certification laboratories [45].

The approach of the Virtual PLC Lab has provided multiple advantages when compared to the conventional laboratory analog approach, as it reduces the complexity of PLC testing. The improvement of this tool can be summarized in the following factors:

- 1) Increased testing speed: Since current high-end computers have higher performance than most PLC devices, the testing speed can be hundreds of times faster than a test with real physical devices.
- 2) Easy test replication: As digital algorithms are deterministic and repeatable, the test conditions can be replicated with precision. This is particularly useful for regression testing during the development process

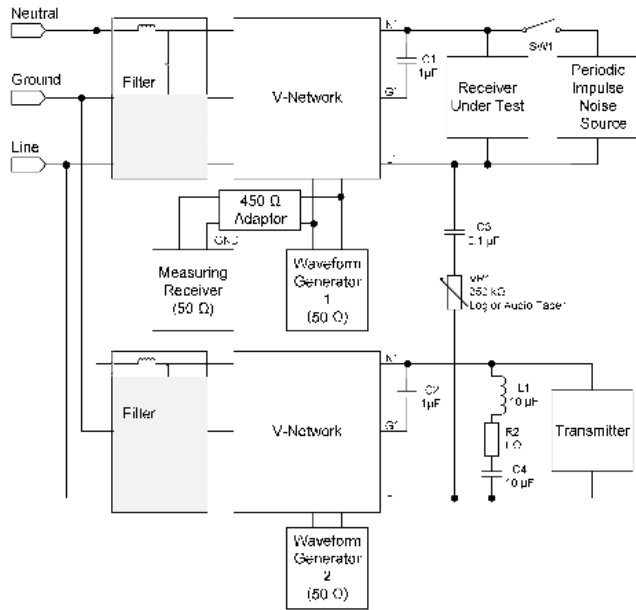

FIGURE 3. Test Setup for Measuring PLC Link Budget and Data Rate ETSI TS 103 909. (Source: [11]).

of the technology or for comparison of performance of different design options, which allows incremental performance improvement of PLC solution designs.

- 3) Reduced development costs: Modems to be validated with Virtual PLC Lab can be emulated in a computer; reducing platform-specific development costs.
- 4) Fully automated tests: Human interaction is minimized, as multiple PLC topologies under different network conditions can now be tested in a fully automated way.

B. TEST METHOD AND METRICS BASED ON ETSI

1) TEST METHOD

The document ETSI TS 103 909 V1.1.1 [11] describes test techniques that can be used to determine the performance of narrowband PLC technologies using any modulation technique in the frequency range 9 kHz to 500 kHz. It contains detailed information so that the data gathering and processing can be replicated in a controlled setup, ensuring fidelity and repeatability.

The PLC performance tests require a setup simulating a transmitter and a receiver, connected through a channel. The setup is defined for a controlled AC mains environment, by means of two isolated mains branches, one for the transmitter and another one for the receiver under test. This test setup is shown in Fig. 3.

The test setup is thoroughly described in [11], and its purpose is having a reliable procedure to independently connect a transmitter and a receiver, through a channel characterized by a nearly flat in-band frequency response, with controlled attenuation and additive noise sources and waveforms. The effect of this network is integrated into the Virtual PLC Lab.

The size of the message used for testing is specified to be 128 bytes. The number of sent messages shall be at least 500 for each measurement of FER. In the present research, for accuracy purposes, the number of sent messages is increased to 10,000 [32]. As the units under test support multiple physical layer options, the test will be performed for each physical configuration and each noise waveform. The transmission power is configured to be 120 dB μ V, the minimum required by the PRIME Alliance [39], [40]. The same transmission power will also be used for G3-PLC, for simpler comparison, based also on the fact that most of the chipsets in the market support both standards, so they are capable of providing the same transmission power.

2) TEST METRICS

This section describes the list of measurements and parameters required for the analysis of the impact of channel disturbances on LV narrowband PLC.

The test metrics calculated for these tests are defined by the ETSI TS 103 909 V1.1.1 [11]. These metrics are given in terms of the link budget and effective data rate. Both values allow a potential user to evaluate the suitability of a specific device, based on their data rate and link budget requirements.

The ETSI document [11] defines the effective Packet layer data rate (DR_{PKT}) as the number of bits delivered to the data-link layer divided by a full formatted packet cycle time. The data rate measures the bits of the data link layer, considering the physical header and preamble as overhead. It is measured at physical level, so the error correction or recovery at upper layers is not considered as a part of the data rate. The purpose of this metric is to provide a measurement of the cost of the physical mechanisms in the data rate available to upper layers.

The ETSI document [11] establishes a FER of 5% as the acceptability limit for narrowband PLC communications, considering that it aims to represent the worst noise amplitude levels that can be found in real deployments. This FER only considers aspects related to the physical layer, not taking into consideration any error correction mechanism at higher layers. Given a physical configuration of the transmitter (modulation scheme) and one specific noise pattern, Virtual PLC Lab will calculate through iterations the minimum reception power that would allow a reception FER equal or better than 5%. Once this reception power limit is obtained, the link budget is assessed as the difference between the nominal transmitter power and the calculated reception power threshold. Therefore, according to [11], the link budget is defined as the maximum attenuation that yields a frame error rate under 5%, given certain testing conditions.

According to ETSI TS 103 909 V1.1.1 [11], the following test metrics, which are related to the noise waveform groups, are defined:

- 1) **Tonal noise link budget:** First, the 25 individual measured link budgets are calculated and identified as $LB_{tonal,i}$ for i from 1 to 25, corresponding to switching

frequencies of $21 + 5i$ kHz. These individually calculated link budgets are averaged. To provide added statistical weight to the most challenged result, while also considering the average, the overall tonal noise link budget is specified to be the lowest of the 25 individually measured link budgets, averaged with the previously calculated average, giving equal weight to those two figures:

$$LB_{\text{tonal}} = \frac{1}{2} \left(\min_{i \in [1, 25]} \{LB_{\text{tonal}, i}\} + \frac{1}{25} \sum_{i=1}^{25} LB_{\text{tonal}, i} \right)$$

- 2) **Periodic impulse noise link budget:** Defined as the link budget measured in presence of the periodic impulse noise. As just one waveform of this type is included in [11], in this case, the link budget is directly the obtained value.
- 3) **Random impulse noise link budget:** Defined as the link budget measured in presence of the random impulse noise. Similarly to the previous case, the random impulse noise link budget is directly the calculated value for the single waveform of this type that is defined in [11].
- 4) **Intentional communicator link budget:** Defined to be the smallest of the four individual intentional communicator link budget values.
- 5) **Composite link budget (LB_{PHY}):** Defined to be the average of the following measurement values: *Unimpaired link budget* (obtained for a noiseless environment), *Tonal noise link budget*, *Periodic impulse noise link budget*, *Random impulse noise link budget* and *Intentional communicator link budget*. The *Unimpaired link budget* averaged for the *Composite link budget* is capped to 80 dB (as defined in 4.7 section of ETSI document [11]). This composite link budget, being an averaged value of different measurements, does not have a direct physical meaning. Nevertheless, the purpose of this magnitude is defined in [11] to be a standard figure of merit to compare communication systems and physical configurations.

These metrics have been adapted to the non-intentional emissions selected from DER:

- 6) **der n link budget:** Individually measured link budget for each of the six DER noises measured at CEDER [46].
- 7) **der average link budget:** Defined to be the average of the six individual link budget values of DER.

In order to complement and extend the information given by these metrics, new metrics are defined as part of the research process:

- 8) **Signal to Noise Ratio (SNR) required for AWGN:** The minimum SNR required in order to decode PHY packets with FER lower than 5% in the presence of AWGN. This type of noise is not commonly present in the PLC network, but this metric will be used as a reference value in the results analysis. SNR value is

obtained instead of the link budget due to the lack of a defined absolute amplitude value for this type of noise.

- 9) **Tonal in-band noise link budget:** Some of the tonal noises included in [11] are out of the bands of the communication systems under test. The link budget related to these noises will be extremely high. To avoid the bias effect of high link budget values related to these noises, a new metric is defined, which performs the same calculations as in the *Tonal noise link budget*, but considering only the disturbances in the communication band, due to either the main frequency or its harmonics. These are the first 13 tonal noises whose main frequencies range from 26 kHz to 86 kHz.

$$LB_{\text{tonal, in-band}} = \frac{1}{2} \left(\min_{i \in [1, 13]} \{LB_{\text{tonal}, i}\} + \frac{1}{13} \sum_{i=1}^{13} LB_{\text{tonal}, i} \right)$$

- 10) **Composite in-band link budget:** Defined to be the average of the following individual measurement values: *Tonal in-band noise link budget*, *Periodic impulse noise link budget*, *Random impulse noise link budget*. This metric is defined in a similar way as the *Composite link budget* but averaging only the link budgets related to noises that have all or part of their power in the working band of the communication technologies under test. In a similar way as in the *Tonal in-band noise link budget*, the aim is to avoid the bias effect of the high link budgets related to noises that do not have power in the communication band.

C. SUMMARY OF PERFORMED VIRTUAL PLC LAB TESTS

G3-PLC and PRIME PLC technologies are put under test in the Virtual PLC Lab setup. These units under test support multiple physical layer options, so tests are performed with 22 physical options:

- 1) 8 options of the physical layer for G3-PLC.
- 2) 14 options of the physical layer for PRIME.

The overall analysis comprises 38 perturbation input sources:

- 1) 25 tonal noises (ETSI)
- 2) 1 periodic impulse noise (ETSI)
- 3) 1 random impulse noise (ETSI)
- 4) 4 intentional communicator noises (ETSI)
- 5) White gaussian noise (Virtual PLC Lab)
- 6) 6 DER noises (field measurements at CEDER)

Virtual PLC Lab tests were run to evaluate the FER of each SNR for all the combinations of the above-mentioned options. As a result, the study compiles the comparison of the performance of 22 options of the physical layer against 38 perturbation sources. Therefore, the testing results include 836 SNR curves for different PLC combinations and the results imply the simulation of the exchange of 549 million frames.

TABLE 1. Prime 1.3.6 and 1.4 physical results summary.

| Parameter | Header Type B* | | | | | | | | | Header Type A | | | | | | Units |
|---|----------------|--------------|----------|----------|----------|-------|-------|-------|----------|---------------|----------|-------|-------|-------|------|-------|
| | Robust DBPSK | Robust DQPSK | DBPSK_CC | DQPSK_CC | D8PSK_CC | DBPSK | DQPSK | D8PSK | DBPSK_CC | DQPSK_CC | D8PSK_CC | DBPSK | DQPSK | D8PSK | | |
| SNR required for AWGN | -1.2 | 1.6 | 3.2 | 5.8 | 11.0 | 9.2 | 14.6 | 20.0 | 3.4 | 6.2 | 11.0 | 9.2 | 14.6 | 20.0 | dB | |
| Packet layer data rate (DR _{PKT}) | 4.8 | 8.8 | 15.4 | 24.5 | 29.2 | 24.5 | 33.5 | 39.2 | 19.1 | 32.9 | 46.1 | 32.9 | 51.3 | 66.1 | kbps | |
| Tonal noise link budget | 38.6 | 33.0 | 32.1 | 27.3 | 17.7 | 14.2 | 9.3 | 4.1 | 30.7 | 27.4 | 17.6 | 14.2 | 9.3 | 4.1 | dB | |
| Tonal in-band noise link budget | 29.1 | 22.7 | 21.8 | 16.4 | 6.1 | 1.4 | -3.2 | -8.3 | 20.2 | 16.5 | 6.1 | 1.4 | -3.2 | -8.2 | dB | |
| Periodic impulse noise link budget | 24.1 | 21.9 | 12.3 | 9.1 | 3.1 | 11.5 | 3.1 | -2.9 | 12.3 | 8.9 | 3.1 | 11.1 | 3.1 | -2.9 | dB | |
| Random impulse noise link budget | 25.9 | 23.1 | 19.3 | 16.5 | 11.3 | 12.3 | 6.5 | 0.9 | 19.1 | 16.3 | 11.3 | 12.3 | 6.5 | 0.9 | dB | |
| Intentional communicator link budget | 37.5 | 37.5 | 31.7 | 27.5 | 22.5 | 21.7 | 15.7 | 10.7 | 31.5 | 27.5 | 22.3 | 21.7 | 15.7 | 10.7 | dB | |
| Composite link budget (LB _{PHY}) | 41.2 | 39.1 | 35.1 | 32.1 | 26.9 | 27.9 | 22.9 | 18.6 | 34.7 | 32.0 | 26.9 | 27.9 | 22.9 | 18.6 | dB | |
| Composite in-band link budget | 26.4 | 22.6 | 17.8 | 14.0 | 6.8 | 8.4 | 2.1 | -3.4 | 17.2 | 13.9 | 6.8 | 8.3 | 2.1 | -3.4 | dB | |
| der04 link budget | 29.5 | 23.1 | 20.3 | 18.1 | 9.7 | 6.3 | 2.1 | -3.3 | 20.1 | 17.9 | 9.7 | 6.3 | 2.1 | -3.1 | dB | |
| der06 link budget | 27.3 | 22.3 | 18.7 | 16.7 | 7.7 | 4.1 | 0.1 | -4.9 | 18.7 | 16.7 | 7.9 | 4.1 | 0.1 | -4.9 | dB | |
| der34 link budget | 53.6 | 50.8 | 48.8 | 46.0 | 40.8 | 40.2 | 34.6 | 29.0 | 48.6 | 46.0 | 40.8 | 40.2 | 34.6 | 29.2 | dB | |
| der36 link budget | 49.4 | 47.0 | 45.0 | 42.6 | 37.2 | 36.8 | 31.2 | 25.6 | 45.0 | 42.4 | 37.2 | 36.8 | 31.2 | 25.8 | dB | |
| der50 link budget | 0.9 | -1.7 | -6.1 | -8.9 | -15.7 | -16.7 | -22.3 | -27.7 | -6.3 | -9.1 | -15.9 | -16.7 | -22.1 | -27.7 | dB | |
| der51 link budget | 6.0 | 3.8 | 0.0 | -2.6 | -9.0 | -10.0 | -15.4 | -20.8 | -0.2 | -2.8 | -9.2 | -10.0 | -15.2 | -20.8 | dB | |
| der average link budget | 27.8 | 24.2 | 21.1 | 18.7 | 11.8 | 10.1 | 5.1 | -0.3 | 21.0 | 18.5 | 11.8 | 10.1 | 5.1 | -0.3 | dB | |

* Header Type B is defined in 1.4 revision of PRIME standard (not available for PRIME 1.3.6)

TABLE 2. G3-PLC physical results summary.

| Parameter | Differential | | | | Coherent | | | | Units |
|---|--------------|-------|-------|-------|----------|------|------|-------|-------|
| | ROBO | DBPSK | DQPSK | D8PSK | ROBO | BPSK | QPSK | 8PSK | |
| SNR required for AWGN | -2.2 | 1.2 | 4.6 | 9.8 | -3.6 | -0.8 | 2.2 | 6.2 | dB |
| Packet layer data rate (DR _{PKT}) | 5.5 | 17.4 | 28.9 | 36.8 | 5.1 | 15.7 | 25.2 | 31.6 | kbps |
| Tonal noise link budget | 44.3 | 37.0 | 23.8 | 16.8 | 44.7 | 38.0 | 34.9 | 22.9 | dB |
| Tonal in-band noise link budget | 37.1 | 28.1 | 13.1 | 5.2 | 37.7 | 29.5 | 26.0 | 12.3 | dB |
| Periodic impulse noise link budget | 29.1 | 26.1 | 21.5 | 15.9 | 28.3 | 27.7 | 26.9 | 19.1 | dB |
| Random impulse noise link budget | 25.1 | 20.5 | 16.3 | 11.5 | 26.7 | 22.3 | 19.7 | 14.9 | dB |
| Intentional communicator link budget | 41.5 | 38.5 | 30.5 | 26.5 | 39.3 | 38.5 | 35.5 | 29.9 | dB |
| Composite link budget (LB _{PHY}) | 44.0 | 40.4 | 34.4 | 30.1 | 43.8 | 41.3 | 39.4 | 33.4 | dB |
| Composite in-band link budget | 30.4 | 24.9 | 17.0 | 10.9 | 30.9 | 26.5 | 24.2 | 15.4 | dB |
| der04 link budget | 28.9 | 27.3 | 20.9 | 16.7 | 28.9 | 27.3 | 25.7 | 19.3 | dB |
| der06 link budget | 29.3 | 27.9 | 22.7 | 15.5 | 28.5 | 27.1 | 26.3 | 20.3 | dB |
| der34 link budget | 55.8 | 49.8 | 42.0 | 37.0 | 56.6 | 51.6 | 48.4 | 41.8 | dB |
| der36 link budget | 51.6 | 45.4 | 38.2 | 33.6 | 52.6 | 47.2 | 44.0 | 37.6 | dB |
| der50 link budget | -0.3 | -4.7 | -9.3 | -14.9 | 1.7 | -3.1 | -5.9 | -10.5 | dB |
| der51 link budget | 5.8 | 1.6 | -2.8 | -8.2 | 7.6 | 3.2 | 0.6 | -4.0 | dB |
| der average link budget | 28.5 | 24.6 | 18.6 | 13.3 | 29.3 | 25.6 | 23.2 | 17.4 | dB |

In this context, the use of the Virtual PLC Lab has proven to be much more efficient than the conventional laboratory analog approach.

V. PERFORMANCE RESULTS OF PLC TECHNOLOGIES

Tables 1 and 2 represent the summary of the results of the tests described in the previous sections developed with the Virtual PLC Lab: Table 1 summarizes the results for both PRIME 1.3.6 and 1.4 PHY layers and Table 2 for G3-PLC PHY layer.

The rows of the tables include the test metrics listed in the methodology (section B.2). This covers disturbance sources of ETSI and DER, metrics defined by ETSI and additional metrics specifically defined for this research purpose.

The columns of the tables represent the available modulation schemes configurations of the physical layer of each PLC technology.

Table 1 presents the results for PRIME technology grouped into two physical configurations: Header Type A and Header

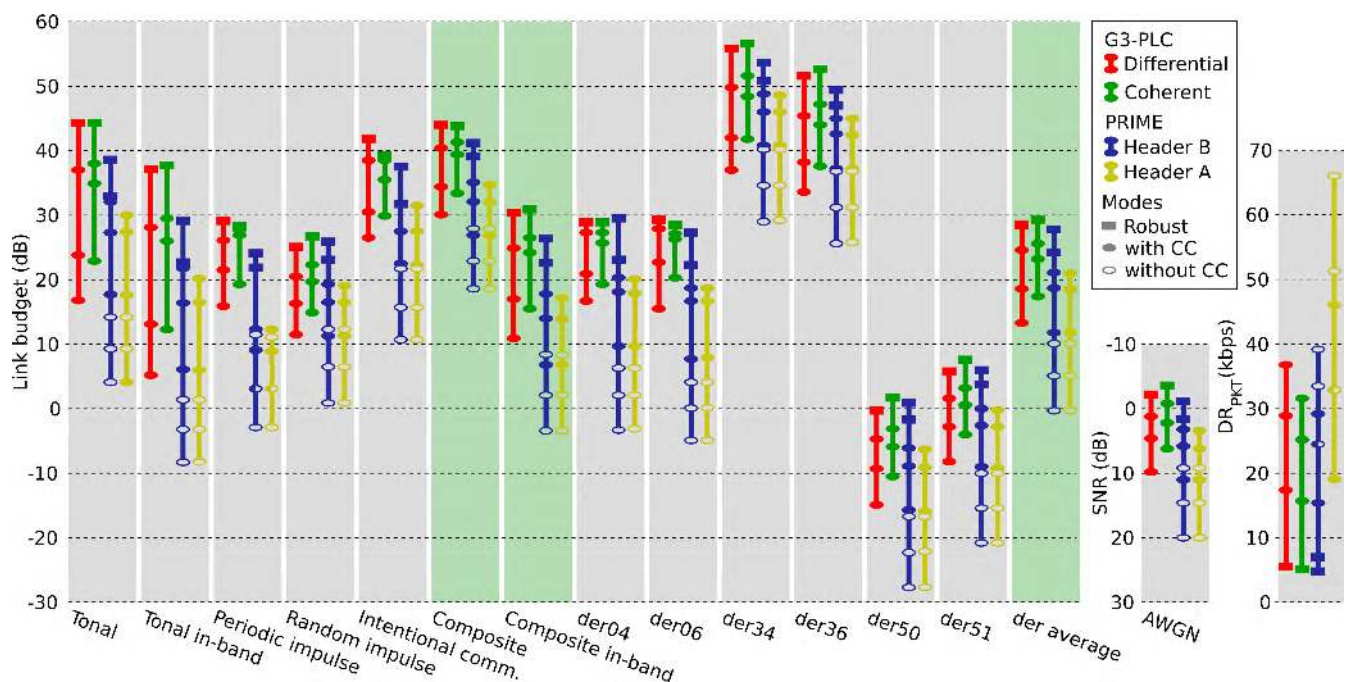

FIGURE 4. Graphical summary of the results.

Type B. The header Type A is common for PRIME 1.3.6 and PRIME 1.4, while the header Type B is available only for PRIME 1.4, and introduces increased physical robustness. Therefore, Table 1 represents the results of both versions of the PRIME standard.

In Table 1, DBPSK, DQPSK, D8PSK are payload modulation schemes without any error correction mechanism. DBPSK_CC, DQPSK_CC, D8PSK_CC use convolutional encoding. Robust DBPSK and Robust DQPSK use both convolutional encoding and repetition by-4.

Table 2 shows the results obtained for G3-PLC standard. These results are grouped into two physical configurations, considering the modulation of the symbols of the payload: differential and coherent modulation.

All payload modulation schemes in Table 2 include convolutional encoding and Reed-Solomon. ROBO modes include repetition by-4.

Fig. 4 depicts the same results presented in Table 1 and Table 2. Three group of results are represented: link budget, SNR required for AWGN and Packet layer data rate (DR_{PKT}). For each column, four bars are included. These bars represent the G3-PLC differential modes (red bar), G3-PLC coherent modes (green bar), PRIME 1.4 with Header B modes (blue bar) and PRIME 1.4 with Header A modes which is equivalent to PRIME 1.3.6 (yellow bar). The markers within the bars represent each of the modulation schemes. These schemes are divided into three categories: robust modes with repetition by 4 (rectangular marker), modes with convolutional encoding (elliptic filled marker) and modes without convolutional encoding (elliptic empty marker). SNR axis is reversed for coherency with the link budget axis, representing that when

the link budget increases for a particular noise, the SNR decreases.

VI. ANALYSIS OF THE IMPACT OF THE CHANNEL DISTURBANCES ON PLC TECHNOLOGIES

This section makes a performance comparison of the main PLC modules and physical capabilities under test. The results shown in the next subsections are calculated as the results for all the physical configurations involved, by averaging the values of *Composite in-band link budget* and *der average link budget* with the same weight.

A. ANALYSIS OF MODULATION AND CHANNEL CODING PERFORMANCE

1) HEADER ROBUSTNESS

Comparing the results in Table 1 for Header Type A and Header Type B with the same modulation schemes, the difference in link budget is minimal, being 0.4 dB on average for DBPSK_CC and less than 0.1 dB for other modulation schemes. This means that, although the preamble and Header Type B are inherently more robust, they do not have a significant influence compared to the non-robust modes. Moreover, since the Header Type B and preamble are much longer, they reduce the available data rate by an important percentage.

From the FER point of view, the use of the Header Type B is only justified for the robust modes. In general, for any PLC technology, if the robustness of the header is too high compared to the robustness of the payload, it is not useful to improve the decoding possibilities of the physical packet.

2) CONVOLUTIONAL ENCODER

Considering the results for the modulation schemes in Table 1, and comparing the columns of modulation schemes with and without the use of the convolutional encoder, it can be concluded that the use of the convolutional encoder increases the link budget in 11.3 dB and decreases the data rate 33%. The Header overhead has a high impact in the overall data rate of a frame, being independent of the convolutional encoder usage, which is applied to the payload only. Therefore, the impact of the convolutional encoder is not so high in the overall frame data rate. Additionally, the *Composite in-band link budget* of the modulation schemes that do not enable the convolutional encoder is lower than 10 dB. Not having any error correction mechanisms makes the decoding process too fragile to single bit errors, due to either tonal noises or impulsive noises.

Modulation schemes without convolutional encoder are not practical for real field scenarios. Although they are defined in the standard, the low link budget and low increase of the effective data rate make them not usable in real deployments, where SNR is neither very high nor stable.

This conclusion is consistent with the ones obtained in [51] and [32]. While [51] reaches this conclusion using real field tests, [32] uses simulations with different metrics, noises and frequency responses. In general, the diverse nature of the noise in PLC requires technologies of error correction in order to achieve good enough performance in real field deployments.

3) COHERENT MODULATION SCHEMES

Comparing the results for coherent and differential modes of Table 2, an increase of 3.0 dB in the link budget is obtained when enabling the coherent decoder. The reason behind this improvement is the fact that for differential modes, a noise in a given symbol affects also to the next one. On the contrary, for the coherent modes, the noise in a particular symbol does not affect to the adjacent ones.

Enabling coherent modulation schemes decreases the data rate by 11%, because one payload carrier out of each 12 is required to be a pilot carrier. Additionally, two equalization symbols are introduced between the Header and the payload.

A decrease of 11% in the data rate, by increasing the link budget by 3.0 dB on average, makes the coherent modulation schemes particularly effective. Coherent modes are able to transmit 89% of the effective data rate compared to the differential modes, but requiring 50% of the received signal power. This means that for coherent modes each effective bit requires 57% of the energy, compared to the differential alternative.

4) REPETITION BY-4 ROBUST MODES

The use of robust modes in Table 2 implies an increase in the link budget average of 4.4 dB, compared to non-robust modes. For this comparison, note that G3-PLC robust modes are always BPSK modulated.

The robust modes in PRIME 1.4 technology (Table 1) increase the link budget in 7.3 dB on average, when compared to their non-robust counterparts.

Both G3-PLC and PRIME 1.4 robustness mechanisms include a by-4 repetition mechanism. This repetition provides 4 times more of energy, and therefore, it could provide a theoretical increased link budget of 6 dB. In a practical implementation, this benefit will be smaller than the theoretical value, because, while link budget increases, signal gets weaker and other effects appear (increased rates of misalignment, Header decoding errors and equalization limitations). Tables 1 and 2 show the results for the case of AWGN for both technologies: robust modes of G3-PLC improve the sensitivity in 3.1 dB and robust modes of PRIME achieve 4.3 dB, being both below the theoretical value of 6 dB as expected.

Moreover, the link budget increase in Table 1 for robust modes is higher than 6 dB (7.3 dB). This means that other factors different than the transmitted energy must be affecting the transmission quality. In this case, the additional improvement comes from the interleaver, which makes the repetition-by-4 system much more robust against highly correlated disturbances. As the interleaver consists of 1-symbol interleaving before the by-4 repetition, once the repetition of the robust mode is applied, it has an effective block size of 4 symbols. This explains the additional robustness for the modes that use interleaving.

5) OTHER PHYSICAL CONFIGURATION PARAMETERS

In this section, the impact of the rest of the physical configuration parameters on the performance of PLC is analyzed. For this purpose, both PRIME and G3-PLC are evaluated in those modulation schemes that show similar configurations: differential modulation schemes, using the most robust Header type (Header Type B for PRIME), with convolutional encoder. Modulation schemes matching these criteria are R-DBPSK, DBPSK_CC, DQPSK_CC and D8PSK_CC in Table 1, and ROBO, DBPSK, DQPSK and D8PSK in Table 2.

Although the comparison is made for similar configurations, there are important differences in the physical layer of the PLC technologies under test:

- 1) Interleaver: PRIME specifies a block interleaver of one symbol whereas G3-PLC specifies a full frame interleaver, which enhances the robustness against burst noises.
- 2) Encoding: Both systems have a convolutional encoder. Additionally, G3-PLC includes a Reed-Solomon outer encoder, which contributes to an increased robustness against the errors not recovered by the convolutional decoder.
- 3) Differential mapping: PRIME uses an intercarrier differential mapping, and G3-PLC applies an intersymbol differential mapping. On one hand, the intercarrier differential technique is expected to be more robust for time-varying frequency responses and impulse noises, because the effects on one symbol do not affect the next one. On the other hand, the intersymbol differential

configuration will handle better frequency responses with a high variation in frequency, as it does not rely on adjacent subcarriers having similar frequency responses. The OFDM symbol configuration of both standards is configured to mitigate their differential approach limitations: shorter G3-PLC symbols mitigate the effect of time-varying frequency responses, and narrower PRIME subcarriers mitigate the effect of the frequency response being different for adjacent subcarriers.

- 4) OFDM parameters: PRIME defines OFDM symbols of 2.24 ms with 97 subcarriers separated 488 Hz per subcarrier, while G3-PLC symbols are specified as 0.75 ms with 36 subcarriers separated 1562 Hz per subcarrier. With this configuration, the longer PRIME OFDM symbols will be more robust both for impulsive and frequency selective noises.

The results of the link budget in Table 2 are, on average, 3.0 dB higher than in Table 1. This difference is due to a combination of the impact of the physical parameters listed above.

B. IMPACT ANALYSIS OF EACH DISTURBANCE TYPE

1) DISTURBANCES DEFINED BY ETSI

Both *Tonal noise* and *Intentional communicator noise* have a narrow spectral density that affects a limited number of subcarriers. This impact is distributed across several symbols. This situation is particularly suitable for the convolutional encoding error correction.

On the contrary, modulation schemes without convolutional encoding offer a very low link budget for narrowband noise situations. The challenge in this scenario is that a correct decoding without convolutional encoding requires that every carrier has a signal higher than the interfering noise.

Moreover, *Tonal noises* above 96 kHz and *Intentional communicator noises* have most of their energy out of the communication band, so their link budget offers much higher values. This is an aspect to be analyzed in the next sections, oriented to the metrics performance.

Both impulsive noises, *Random impulsive noise* and *Periodic impulsive noise*, have a much wider spectrum affecting most of the subcarriers. The disturbance introduced will also be mitigated with the help of the convolution encoding, although its effectiveness is lower. In this situation, the impulse rate, symbol size and interleaver effective size are critical factors of the decoding process. Additionally, depending on the symbols affected by the impulsive noise, the noise may affect several physical modules as the alignment of the preamble, the header decoding, the equalization or the automatic gain control mechanisms. These effects make impulsive noises impact much more challenging to be decoded. This is the reason why the *Periodic impulsive noise* and *Random impulse noise* are the ones with the minimum link budget in the ETSI noise collection for most modulation schemes.

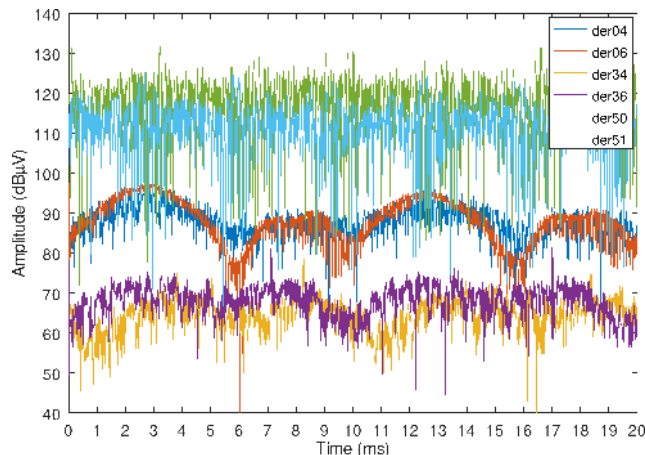

FIGURE 5. DE. noises in-band power representation in time with a resolution of 50 μ s.

2) DISTURBANCES CAUSED BY DER

DER photovoltaic system scenarios have up to 25 dB link budget difference, depending on the specific implementation of the Photovoltaic inverter and the conditions of the grid where they are located (*der04*, *der06*, *der34* and *der36*). These noises have a wide spectral density, and their most significant aspect is their periodic time pattern, which is synchronous with the AC mains (50 Hz). This can be observed in Fig. 5, representing DER noises power evolution in time. Although the *Periodic impulsive noise* is also synchronous with the network, its frequency and time patterns are very different, not being possible to relate with the characteristics of the captured DER noises.

Finally, the combined effect of the wind turbines and distributed storage system have the worst impact in the overall research. These disturbances (*der50* and *der51*) reduce the link budget in 49.6 dB compared to the best photovoltaic scenario (*der34* and *der36*). An interesting correlation is found between *der50*, *der51* noises and ETSI *Random impulsive noise*. They have an equivalent shape, both in spectral density and power evolution in time, depicted in Fig. 6 and Fig. 7. The in-band power of ETSI *Random impulsive noise* (96.3 dB μ V) is 24.4 dB higher than the noise power of *der50* and 18.2 dB higher in the case of *der51*. An equivalent difference is found in the link budget with average differences of 26.3 dB and 19.9 dB obtained from Table 1 and Table 2.

It can be concluded that ETSI disturbances represent the shape of the worst noise impact found in real DER situations. Nevertheless, it does not cover the high level of power found in DER wind turbines and distributed storage system noises. Other noise patterns found for photovoltaic systems in this DER noise collection are not represented in ETSI disturbances collection.

C. ANALYSIS OF THE PERFORMANCE METRICS

1) ETSI METRICS

Variability of the link budgets is high depending on the noise under test. Differences up to 20 dB can be found between

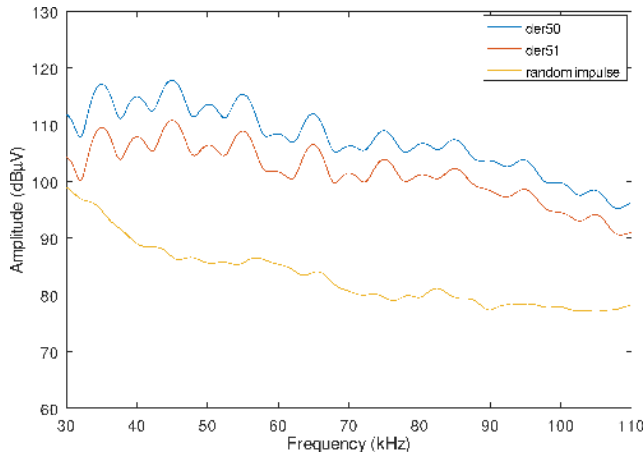

FIGURE 6. der50, der51 and random impulsive noises spectrum representation with resolution bandwidth of 2 kHz.

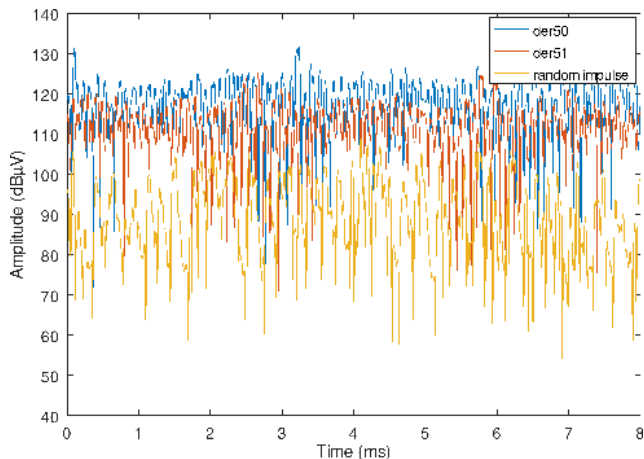

FIGURE 7. der50, der51 and random impulsive noises in-band power representation in time with a resolution of 50 μs.

Tonal noise link budget and the Random impulse noise link budget. These high variations affect directly to the composite value that will be totally dependent on the noise collection and how their impacts are weighed when averaging them to create the Composite link budget.

Additionally, the Composite link budget metric includes Unimpaired link budget impact, which is up to 80 dB. This means that the composite result is highly biased from the reality due to this unimpaired noise, which is not representative for real field scenarios. This is more visible in the less robust modulation schemes such as D8PSK. Composite link budget for D8PSK with and without unimpaired noise has up to 10 dB difference.

Tonal Noises above 96 kHz and Intentional Communicator Noises have most of their energy out of the communication band, so their link budget offers very high values.

These aspects combined could mask the detail of the most representative noises for the communication band. This exposes a need of new metrics definition.

2) RESEARCH ADDED METRICS

Research added in-band metrics consider only noises that cause disturbances in the CENELEC-A band used by PLC technologies under study. Unimpaired noise, Tonal noises above 96 kHz and Intentional communicator noises are left out of the scope of these in-band metrics, in order to reduce the bias effect of nearly noiseless scenarios.

Data analysis confirms the interest of these new metrics defined for the scope of this research. Tonal in-band noise link budget compared to Tonal noise link budget is 10.3 dB lower in average. This same comparison for Composite in-band link budget is 17.5 dB lower than overall Composite link budget. Proposed in-band metrics complement the existing ones, representing the effects in the situations in which there is noise in the communications band.

VII. CONCLUSIONS AND FUTURE EVOLUTION

The results obtained provide important conclusions about the impact of different types of noise on narrowband PLC, which are being currently demanded by CENELEC [6], CIREDCIGRÉ [7], IEEE [8], [9], and IEC [10], in the form of measurements under controlled and replicable conditions, both in laboratory and real field. These results will be useful for the evolution of the communication technologies (increased robustness, higher data rate) and the regulation of immunity levels.

Firstly, the usability of the results for the evolution of the communication technologies is explained. The following technical evidences are provided:

- 1) Modulation schemes without convolutional encoder are not practical for real field scenarios, an observation that is consistent with previous studies [32], [51].
- 2) Results confirm that if the robustness of the header is too high compared to the robustness of the payload, it is not useful to improve the decoding possibilities of the physical packet.
- 3) The low data rate decrease compared to a significant link budget increase, makes the coherent modulation schemes particularly interesting.
- 4) Robust by-4 repetition mechanism provides more energy and its effectiveness depends on the noise patterns and the relation between the repetition mechanism and the interleaver.

These technical conclusions open several optimization lines. Power line standardization committees need to be proactive and keep evolving their technologies so performance and flexibility for new applications is ensured. A continuous improvement approach is critical so power line solutions can be extended worldwide. During the last decade multiple Smart Grid projects have been deployed, and in the years to come many more countries will invest in the automation, knowledge and smartization of their distribution grid.

The optimization lines require the evaluation of the performance impact of those physical configuration differences

between the PLC technologies under test. With this paradigm, a list of five physical configuration parameters that could be covered is identified:

- 1) Interleaver length impact in the decoding capabilities.
- 2) Reed-Solomon outer encoder as an addition to the convolutional encoder.
- 3) Differential mapping intercarrier and intersymbol performance.
- 4) Different OFDM configurations regarding symbol length, number of subcarriers and frequency distances between subcarriers.
- 5) Analyze other technical possibilities such as tone mapping.

Secondly, the usability of the results for the regulation of immunity levels is covered. Power line communications will face noise disturbances coming from different sources. Electricity generation and consumption paradigm is under transformation as distributed generation is gaining impact. In order to overcome these challenges, the first step is to gain knowledge, and this performed research offers useful data.

Both ETSI and real DER noises have been analyzed. Since ETSI representation does not cover some DER noise challenges and characteristics. Results show that DER real noises have a critical impact in PLC. In this line, it is claimed that DER specific noises are part of performance studies and disturbances collections such as ETSI [11].

There are different approaches in order to cope with in-band disturbances situations as concluded by [47]. One approach is focused on strictly limiting the emission of electrical equipment whether they are within a PLC context or not. The alternative approach softens emitting restrictions addressing each issue case-by-case. In any case, standardization committees need to work in a solution where Non-Mains Communicating Equipment and Mains Communicating Technologies cope with each other.

PLC community needs to keep a close collaboration with standardization committees with the aim of providing regulatory results within the 2 to 150 kHz frequency range. As stated in the introduction and confirmed with the results provided, future work should cover the lack of specific regulation regarding compatibility and emission levels.

REFERENCES

- [1] *Europe's Top Twenty Power Industry Players 2016*, Prospex Research, Brighton, U.K., Jun. 2016.
- [2] N. Andreadou, M. O. Guardiola, and G. Fulli, "Telecommunication technologies for smart grid projects with focus on smart metering applications," *Energies J.*, vol. 9, no. 5, p. 375, 2016.
- [3] A. Mohos and J. Ladányi, "Emission measurement of a solar park in the frequency range of 2 to 150 kHz," in *Proc. Int. Symp. Electromagn. Compat. (EMC)*, Amsterdam, The Netherlands, Aug. 2018, pp. 1024–1028.
- [4] J. Meyer, M. Bollen, H. Amaris, A. M. Blanco, A. Gil de Castro, J. Desmet, M. Klatt, Ł. Kocewiak, S. Rönnerberg, and K. Yang, "Future work on harmonics—Some expert opinions Part II—Supraharmonics, standards and measurements," in *Proc. 16th Int. Conf. Harmon. Quality Power (ICHQP)*, Bucharest, Romania, May 2014, pp. 909–913. doi: 10.1109/ICHQP.2014.6842871.
- [5] M. Bollen, M. Olofsson, A. Larsson, S. Rönnerberg, and M. Lundmark, "Standards for supraharmonics (2 to 150 kHz)," *IEEE Electromagn. Compat. Mag.*, vol. 3, no. 1, pp. 114–119, 1st Quart., 2014.
- [6] "Electromagnetic interference between electrical equipment/systems in the frequency range below 150 kHz," Tech. Rep. CENELEC SC 205A Study Report Ed. 3 SC 205A/Sec0400/R, Oct. 2015.
- [7] M. H. J. Bollen, S. Rönnerberg, and F. Zavoda, "CIGRE/CIPED C4.24—Power quality in the future grid—first introduction," in *Proc. Great Lakes Symp. Smart Grids*, Chicago, IL, USA, 2014, pp. 1–5.
- [8] *IEEE Guide for Identifying and Improving Power Quality in Power Systems. IEEE 1250-2018*. Accessed: Mar. 19, 2019. [Online]. Available: <https://standards.ieee.org/content/ieee-standards/en/standard/1250-2018.html>
- [9] "On the aim and scope of TC 7—Document for the TC 7 inaugural annual meeting 2012," IEEE EMC Soc. Tech. Committee 7—Low Freq. EMC, Int. Organism, Newark, NJ, USA, Aug. 2012.
- [10] IEC SC 77A. *Standardization in the Field of Electromagnetic Compatibility With Regard to Low Frequency Phenomena*. Accessed: May 18, 2019. [Online]. Available: <https://www.iec.ch/dyn/www/f?p=103:7:1384>
- [11] *Power Line Telecommunications (PLT) Narrow Band Transceivers in the Range 9 kHz to 500 kHz Power Line Performance Test Method Guide*, document ETSI Technical Committee Powerline Communications Technical Specification ETSI TS 103 909, 2012.
- [12] *IEEE Standard for Low-Frequency (Less Than 500 kHz) Narrowband Power Line Communications for Smart Grid Applications*, IEEE Standard 1901.2-2013, 2013.
- [13] A. Mathur, M. R. Bhatnagar, and B. K. Panigrahi, "Maximum likelihood decoding of QPSK signal in power line communications over Nakagami-m additive noise," in *Proc. IEEE Int. Symp. Power Line Commun. Appl. (ISPLC)*, Austin, TX, USA, Mar./Apr. 2015, pp. 7–12. doi: 10.1109/ISPLC.2015.7147581.
- [14] A. Mathur, M. R. Bhatnagar, and B. K. Panigrahi, "Performance evaluation of PLC under the combined effect of background and impulsive noises," *IEEE Commun. Lett.*, vol. 19, no. 7, pp. 1117–1120, Jul. 2015.
- [15] A. Dubey and R. K. Mallik, "PLC system performance with AF relaying," *IEEE Trans. Commun.*, vol. 63, no. 6, pp. 2337–2345, Jun. 2015.
- [16] W. Liu, M. Sigle, and K. Dostert, "Channel phase distortion and its influence on PLC systems," in *Proc. IEEE Int. Symp. Power Line Commun. Appl.*, Beijing, China, Mar. 2012, pp. 268–273. doi: 10.1109/ISPLC.2012.6201341.
- [17] J. Mitra and L. Lampe, "Coded narrowband transmission over noisy powerline channels," in *Proc. IEEE Int. Symp. Power Line Commun. Appl.*, Dresden, Germany, Mar./Apr. 2009, pp. 143–148. doi: 10.1109/ISPLC.2009.4913419.
- [18] G. Ndo, P. Siohan, and M.-H. Hamon, "OFDM/OQAM performance analysis under asynchronous impulsive noise," in *Proc. IEEE Int. Symp. Power Line Commun. Appl.*, Dresden, Germany, Mar./Apr. 2009, pp. 160–165. doi: 10.1109/ISPLC.2009.4913422.
- [19] A. Sendin, I. Berganza, A. Arzuaga, A. Pulkkinen, and I. H. Kim, "Performance results from 100,000+ PRIME smart meters deployment in Spain," in *Proc. IEEE 3rd Int. Conf. Smart Grid Commun.*, Nov. 2012, pp. 145–150. doi: 10.1109/SmartGridComm.2012.6485974.
- [20] A. Sendin, A. Llano, A. Arzuaga, and I. Berganza, "Field techniques to overcome aggressive noise situations in PLC networks," in *Proc. IEEE Int. Symp. Power Line Commun. Appl.*, Apr. 2011, pp. 113–117. doi: 10.1109/ISPLC.2011.5764374.
- [21] A. Sendin, A. Llano, A. Arzuaga, and I. Berganza, "Strategies for PLC signal injection in electricity distribution grid transformers," in *Proc. IEEE Int. Symp. Power Line Commun. Appl.*, Udine, Italy, Apr. 2011, pp. 346–351. doi: 10.1109/ISPLC.2011.5764420.
- [22] A. Sendin, I. Peña, and P. Angueira, "Strategies for power line communications smart metering network deployment," *Energies*, vol. 7, no. 4, pp. 2377–2420, 2014.
- [23] J. Slacik, P. Mlynek, R. Fujdiak, J. Misurec, and P. Silhavy, "Performance evaluation of multi-carrier power line communication systems in real condition for smart grid neighborhood area networks," in *Proc. 9th Int. Congr. Ultra Mod. Telecommun. Control Syst. Workshops (ICUMT)*, Munich, Germany, Nov. 2017, pp. 391–397. doi: 10.1109/ICUMT.2017.8255157.
- [24] L. González-Sotres, C. Mateo, P. Frías, C. Rodríguez-Morcillo, and J. Matanza, "Replicability analysis of PLC PRIME networks for smart metering applications," *IEEE Trans. Smart Grid*, vol. 9, no. 2, pp. 827–835, Mar. 2018. doi: 10.1109/TSG.2016.2569487.

- [25] A. Sanz, D. Sancho, C. Guemes, and J. A. Cortés, "A physical layer model for G3-PLC networks simulation," in *Proc. IEEE Int. Symp. Power Line Commun. Appl. (ISPLC)*, Madrid, Spain, Apr. 2017, pp. 1–6. doi: [10.1109/ISPLC.2017.7897116](https://doi.org/10.1109/ISPLC.2017.7897116).
- [26] M. Hoch, "Comparison of PLC G3 and PRIME," in *Proc. IEEE Int. Symp. Power Line Commun. Appl. (ISPLC)*, Udine, Italy, Sep. 2011, pp. 165–169. doi: [10.1109/ISPLC.2011.5764384](https://doi.org/10.1109/ISPLC.2011.5764384).
- [27] J. Matanza, S. Alexandres, and C. Rodriguez-Morcillo, "Performance evaluation of two narrowband PLC systems: PRIME and G3," *Comput. Standards Interfaces*, vol. 36, no. 1, pp. 198–208, 2013.
- [28] A. Fernandez, A. Sendin, M. Sharma, A. Brunschweiler, and M. Sedjai, "Experimental concept definition and validation to overcome CENELEC A band noise with the use of FCC band overlays," in *Proc. IEEE Int. Symp. Power Line Commun. Appl. (ISPLC)*, Praha, Czech Republic, Apr. 2019, pp. 1–6. doi: [10.1109/ISPLC.2019.8693349](https://doi.org/10.1109/ISPLC.2019.8693349).
- [29] I. Arechalde, M. Castro, I. García-Borreguero, A. Sendin, I. Urrutia, and A. Fernandez, "Performance of PLC communications in frequency bands from 150 kHz to 500 kHz," in *Proc. IEEE Int. Symp. Power Line Commun. Appl. (ISPLC)*, Madrid, Spain, Apr. 2017, pp. 1–5. doi: [10.1109/ISPLC.2017.7897123](https://doi.org/10.1109/ISPLC.2017.7897123).
- [30] A. Van Laere, C. Wawrzyniak, S. Bette, and V. Moeyaert, "Development, validation and utilization of an ITU-T G.9903 PHY simulator for communication performance evaluation," in *Proc. Int. Symp. Power Line Commun. Appl. (ISPLC)*, Bottrop, Germany, Mar. 2016, pp. 167–172. doi: [10.1109/ISPLC.2016.7476276](https://doi.org/10.1109/ISPLC.2016.7476276).
- [31] A. Upadhyay, A. Gupta, and V. Kumar, "Comparative study of narrow band PLCs physical layer under AWGN and narrowband interferer," in *Proc. IEEE Annu. India Conf. (INDICON)*, New Delhi, India, Dec. 2015, pp. 1–4. doi: [10.1109/INDICON.2015.7443190](https://doi.org/10.1109/INDICON.2015.7443190).
- [32] A. Llano, I. Angulo, P. Angueira, T. Arzuaga, and D. de la Vega, "Analysis of the channel influence to power line communications based on ITU-T G.9904 (PRIME)," *Energies*, vol. 9, no. 1, p. 39, 2016.
- [33] B. Mölders, T. M. Pletzer, M. Wächter, and M. Koch, "Experimental investigations of electrical influences on power line communication performance in distribution grid applications," in *Proc. CIRED Workshop*, Helsinki, U.K., 2016, pp. 1–4. doi: [10.1049/cp.2016.0732](https://doi.org/10.1049/cp.2016.0732).
- [34] P. Mlynek, R. Fudziak, J. Misurec, and J. Slacik, "Experimental measurements of noise influence on narrowband power line communication," in *Proc. 8th Int. Congr. Ultra Modern Telecommun. Control Syst. Workshops (ICUMT)*, Oct. 2016, pp. 94–100. doi: [10.1109/ICUMT.2016.7765339](https://doi.org/10.1109/ICUMT.2016.7765339).
- [35] G. Hallak, C. Niess, and G. Bumiller, "Measurement setup for notch evaluation of narrowband PLC devices," in *Proc. IEEE Global Commun. Conf. (GLOBECOM)*, Singapore, Dec. 2017, pp. 1–6. doi: [10.1109/GLOBECOM.2017.8254463](https://doi.org/10.1109/GLOBECOM.2017.8254463).
- [36] J. Matanza, S. Alexandres, and C. Rodriguez-Morcillo, "PRIME performance under impulsive noise environments," in *Proc. IEEE Int. Symp. Power Line Commun. Appl. (ISPLC)*, Beijing, China, Mar. 2012, pp. 380–385. doi: [10.1109/ISPLC.2012.6201297](https://doi.org/10.1109/ISPLC.2012.6201297).
- [37] I. H. Kim, B. Varadarajan, and A. Dabak, "Performance analysis and enhancements of narrowband OFDM powerline communication systems," in *Proc. IEEE Int. Conf. Smart Grid Commun.*, Gaithersburg, MD, USA, Oct. 2010, pp. 362–367. doi: [10.1109/SMARTGRID.2010.5622070](https://doi.org/10.1109/SMARTGRID.2010.5622070).
- [38] S. Robson, A. Haddad, and H. Griffiths, "A new methodology for network scale simulation of emerging power line communication standards," *IEEE Trans. Power Del.*, vol. 33, no. 3, pp. 1025–1034, Jun. 2018. doi: [10.1109/TPWRD.2016.2595639](https://doi.org/10.1109/TPWRD.2016.2595639).
- [39] *Specification for PowerLine Intelligent Metering Evolution V1.3.6*, PRIME Alliance, Brussels, Belgium, 2012.
- [40] *Specification for PowerLine Intelligent Metering Evolution V1.4*, PRIME Alliance, Brussels, Belgium, 2014.
- [41] *PRIME Technology Whitepaper (PHY, MAC, Convergence layers)*, PRIME Alliance, Brussels, Belgium, 2008.
- [42] PRIME Alliance. (2014). *PRIME V1.4 White Paper*. Accessed: May 18, 2019. [Online]. Available: https://www.prime-alliance.org/wp-content/uploads/2014/10/whitePaperPrimeV1p4_final.pdf
- [43] *Narrowband Orthogonal Frequency Division Multiplexing Power Line Communication Transceivers for PRIME Networks*, document ITU-T G.9904, 2012.
- [44] *Narrowband Orthogonal Frequency Division Multiplexing Power Line Communication Transceivers for G3-PLC Networks*, document ITU-T G.9903, 2017.
- [45] A. L. Palacios, X. O. Barañano, D. de la Vega Moreno, I. A. Pita, and T. A. Canals, "Virtual power-line communications laboratory for technology development and research," in *Proc. Int. Conf. Remote Eng. Virtual Instrum. (REV)*, Dusseldorf, Germany, 2018, pp. 128–135.
- [46] N. Uribe, "Análisis de la capacidad de PRIME para gestión de red en entornos con generación distribuida y sistemas de almacenamiento," Ph.D. dissertation, Dept. Ingeniería de Comunicaciones, Universidad País Vasco, Leioa, Spain, 2017.
- [47] N. Uribe-Pérez, I. Angulo, L. Hernández, T. Arzuaga, D. De La Vega, and A. Arrinda, "Study of unwanted emissions in the CENELEC-A band generated by distributed energy resources and their influence over narrow band power line communications," *Energies J.*, vol. 9, no. 12, p. 1007, 2016.
- [48] *Information Technology—Control Network Protocol—Part 3: Power Line Channel Specification*, ISO/IEC 14908-3:2012, 2012.
- [49] *The Centre for the Development of Renewable Energy Sources (CEDER) of the Research Centre for Energy, Environment and Technology (CIEMAT)*. Accessed: May 18, 2019. [Online]. Available: <http://www.ciemat.es/CEDERportal>
- [50] I. Fernandez, N. Uribe-Pérez, I. Eizmendi, I. Angulo, D. de la Vega, A. Arrinda, and T. Arzuaga, "Characterization of non-intentional emissions from distributed energy resources up to 500 kHz: A case study in Spain," *Int. J. Electr. Power & Energy Syst.*, vol. 105, pp. 549–563, Feb. 2019. Accessed: May 18, 2019. doi: [10.1016/j.ijepes.2018.08.048](https://doi.org/10.1016/j.ijepes.2018.08.048).
- [51] A. Sendin, A. Llano, and P. Angueira, "Análisis de la utilización efectiva de los esquemas de modulación de las especificaciones PRIME para la lectura remota de contadores," in *Proc. XIX Telecom I+D Spanish Conf.*, Madrid, Spain, Nov. 2009.



ASIER LLANO (M'11) was born in Bilbao, Bizkaia, Spain, in 1980. He received the M.S. degree in telecommunications engineering and the M.S. degree in information technology on wireless networks from the University of the Basque Country (UPV/EHU), Bilbao, Spain, in 2003 and 2013, respectively.

He is currently a Research and Development Manager with the Metering Business Unit, ZIV Automation, Bilbao. He is contributing to reshape the utilities of the future by creating the next generation of devices to support the Advanced Metering and e-Mobility Infrastructure. He is part-time working on this research thesis on power line communications. His professional experience includes the design and development of embedded devices for the industrial sector. His technical knowledge was on embedded software, industrial electronics, communications, RF, and signal processing. He has authored more than 15 articles. He holds one patent. His research interests include power line communications, smart grids, signal processing, and open standards evolution.

Mr. Llano is an Active Member of PRIME TWG, and G3-PLC Alliance and Meters & More Alliance.



DAVID DE LA VEGA (M'10) received the M.S. and Ph.D. degrees in telecommunication engineering from the University of the Basque Country (UPV/EHU), in 1996 and 2008, respectively, where he joined the Radiocommunications and Signal Processing Research Group, Department of Communications Engineering, in 1998.

He is currently an Associate Professor, working on teaching and researching on radar and propagation. His research interest includes telecommunications and renewable systems, such as the characterization of wind turbine impact on radiocommunication services and communications for smart grids applications.



ITZIAR ANGULO (S'09–M'10) received the M.S. and Ph.D. degrees in telecommunications engineering from the Bilbao Engineering College, University of the Basque Country, Spain, in 2007 and 2013, respectively, where she has been a part of the Radiocommunications and Signal Processing (TSR) Research Group, since 2005, and she has been involved in several research projects in the digital terrestrial television and digital radio broadcasting area.

After five years of postdoctoral experience, she is currently an Associate Professor with the Department of Applied Mathematics, University of the Basque Country, where she continues with the research activities within the TSR Group. She is currently involved in the characterization of the electrical grid as a communication channel for PLC, and the study of new data transmission techniques for smart metering, monitoring, and management of the future smart grids.



LAURA MARRON was born in Vitoria, Alava, Spain, in 1985. She received the M.S. degree in telecommunications engineering from the University of the Basque Country (UPV/EHU), Bilbao, Spain, in 2008, and the Executive M.B.A. degree from the Deusto Business School, University of Deusto, Bilbao, in 2018. She participated in the Value Innovation Program, INSEAD, Fontainebleau, France, in 2018, and Global Gateway Program, Fordham Gabelli School of Business, New York, NY, USA, in 2018.

She is currently a Corporate Product Development Manager with ZIV Automation, Bilbao. Her professional experience as an Application Engineer and a Project Manager include the electricity utility sector. She has a solid technical background in smart grid, smart metering, and communications. She is responsible for complex AMI products and managing key clients as high-level technological reference. She has authored more than ten articles. Her research interests include power line communications, smart grids applications, LV network operation and management, and data analytics.

Ms. Marron is a Certification TF Leader & Technical Working Group Member of PRIME TWG Alliance. She collaborates in INSPIRA STEAM through mentoring/orientation/coaching actions done by professional women within the sciences sector.

• • •