



iJRASET

International Journal For Research in
Applied Science and Engineering Technology



INTERNATIONAL JOURNAL FOR RESEARCH

IN APPLIED SCIENCE & ENGINEERING TECHNOLOGY

Volume: 11 Issue: IV Month of publication: April 2023

DOI: <https://doi.org/10.22214/ijraset.2023.51133>

www.ijraset.com

Call:  08813907089

E-mail ID: ijraset@gmail.com

Implementation of Full Adder Using Nand Gates

K. Anusuya¹, Prof. Dr. S. Kavitha

^{1,2}Hindustan Institute of Technology

Abstract: In digital electronics, there are different types of logic circuits used to perform different kinds of arithmetic operations. One of them is adder.

Adder (or Binary Adder) is a combinational logic circuit that performs the addition of two or more binary numbers and gives an output sum. There are two types of adders present namely, half adder and fulladder. Since, adder are logic circuits, thus they are implemented using different types of digital logic gates such as OR gate, AND gate, NOT gate, NAND gates, NOR gates, etc. In this article, we will discuss the Full Adder Realization using NAND Gates. But before that let's have a look into the basics of full adder.

Keywords: Full adder, NAND gates

I. INTRODUCTION

A Full-adder circuit adds three one-bit binary numbers (A, B, Cin) and outputs two one-bit binary numbers, a Sum (S) and a carry (Cout). It is usually done using two AND gates, two Exclusive-OR gates and an OR gate. NAND gate is one of the simplest and cheapest logic gates available. It is also called a universal gate because combinations of it can be used to accomplish functions of other basic gates. Create a Full-Adder circuit using only NAND gates. NAND gate is one of the universal gates and can be used to implement any logic design. A combinational logic circuit that can add two binary digits (bits) and a carry bit, and produces a sum bit and a carry bit as output is known as a full-adder. In other words, a combinational circuit which is designed to add three binary digits and produces two outputs (sum and carry) is known as a full adder. Thus, a full adder circuit adds three binary digits, where two are the inputs and one is the carry forwarded from the previous addition. There are different types of logic circuits used to perform different kinds of arithmetic operations. One of them is adder.

Adder (or Binary Adder) is a combinational logic circuit that performs the addition of two or more binary numbers and gives an output sum. There are two types of adders present namely, half adder and full adder. Full adders are complex and difficult to implement when compared to half adders.

Two of the three bits are same as before which are A, the augend bit and B, the addend bit.

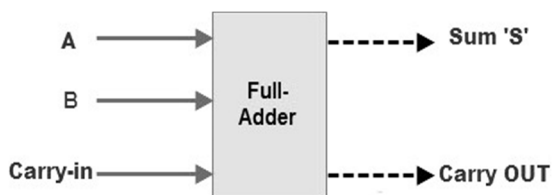

Figure 1: Full adder block diagram

II. EXISTING SYSTEM

Design of full Adder using Norgate:

The existing system use design of full adder using NOR gate. Implementation of a full adder using NAND gates has certain advantages over implementing a full adder using NOR gates. They are,

- 1) **Simplicity:** The implementation of a full adder using NAND gates is relatively simpler than using NOR gates. NAND gates are known to be universal gates, which means that any logic circuit can be built using only NAND gates. As a result, using NAND gates for implementing a full adder reduces the complexity of the overall circuit.
- 2) **Fewer gates:** Using NAND gates for implementing a full adder requires fewer gates compared to using NOR gates. In other words, the circuit using NAND gates will have fewer components, resulting in a lower cost and lower power consumption.
- 3) **Faster Operation:** NAND gates typically have faster propagation delays compared to NOR gates. As a result, the implementation of a full adder using NAND gates will have a faster operating speed than using NOR gates.
- 4) **Reduced Power Consumption:** The use of NAND gates for implementing a full adder reduces power consumption. This is because NAND gates are known to consume less power compared to NOR gates.

III. PROPOSED SYSTEM

Design of full adder using Nandgates:

Overall, the implementation of a full adder using NAND gates has advantages in terms of simplicity, component count, speed, and power consumption overimplementing a full adder using NOR gates.

TRUTH TABLE:

The following is the truth table of the full-adder circuit

Inputs			Outputs	
A	B	C _{in}	S (Sum)	C _{out} (Carry)
0	0	0	0	0
0	0	1	1	0
0	1	0	1	0
0	1	1	0	1
1	0	0	1	0
1	0	1	0	1
1	1	0	0	1
1	1	1	1	1

Hence, from the truth table, it is clear that the sum output of the fulladder is equal to 1 when only 1 input is equal to 1 or when all the inputs are equal to 1. While the carry output has a carry of 1 if two or three inputs are equal to 1.

The output equations of the full adder can be obtained from the truth table of the full adder. These equations are as follows –

Sum Output :

$$\text{Sum, } S = A' B' C_{in} + A' B C_{in} + A B' C_{in}$$

$$+ A B C_{in} = A \oplus B \oplus C_{in}$$

Carry Output :

$$\text{Carry, } C_{out} = A B + A C_{in} + B C_{in}$$

Full-Adder circuit using only NAND gates. NAND gate is one of the universal gates and can be used to implement any logic design. A combinational logic circuit that can add two binary digits (bits) and a carry bit, and produces a sum bit and a carry bit as output is known as a full-adder. Now, let us discuss the realization of Full Adder with NAND gates.

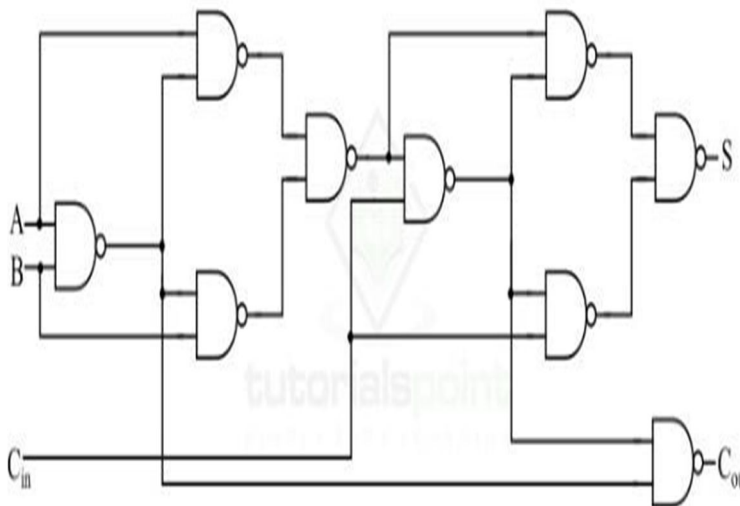

From the logic circuit diagram of the full adder using NAND gates, we can see that the full adder requires 9 NAND gates.

Equation of the sum output for the full adder circuit with NAND gates is obtained as follows –

$$S = \overline{\overline{(A \oplus B)} \cdot \overline{(A \oplus B)} C_{in}} \cdot \overline{C_{in}} \cdot \overline{(A \oplus B)} C_{in} = A \oplus B \oplus C_{in}$$

Where,

$$A \oplus B = \overline{\overline{A} \cdot \overline{AB}} \cdot \overline{\overline{B} \cdot \overline{AB}}$$

And equation of the carry output of the full adder circuit with NAND gate is given by,

$$C_{out} = \overline{\overline{C_{in}} \cdot \overline{(A \oplus B)}} \cdot \overline{AB} = AB + (A \oplus B) C_{in}$$

There are several advantages of implementing a full adder using NAND gates:

- 1) *Simplicity*: NAND gates are one of the simplest logic gates to implement, and using them to implement a full adder reduces the overall complexity of the circuit.
- 2) *Cost-effectiveness*: NAND gates are inexpensive to produce and are widely available in ICs. Using them to implement a full adder can result in a cost-effective design.
- 3) *Reduced size*: Using NAND gates can result in a smaller circuit size, which can be important for applications where space is limited.
- 4) *Improved reliability*: NAND gates are known for their high reliability, and using them in a full adder can result in a more reliable circuit.
- 5) *Ease of modification*: Since NAND gates are basic building blocks of digital circuits, modifying a circuit implemented using NAND gates is relatively easy, making it convenient to make changes to the design as needed.

Overall, using NAND gates to implement a full adder offers several advantages, including simplicity, cost-effectiveness, reduced size, improved reliability, and ease of modification.

Here are some applications and uses of implementing a full adder using NAND gates:

- a) *Digital calculators*: Full adders are used in digital calculators to perform arithmetic addition of two binary numbers. Implementing a full adder using NAND gates reduces the number of gates required, which simplifies the design and reduces the size of the circuit.
- b) *Microprocessors*: Full adders are used in microprocessors to perform arithmetic addition of two binary numbers. Implementing a full adder using NAND gates reduces the propagation delay, which increases the speed of the microprocessor.
- c) *Digital signal processing*: Full adders are used in digital signal processing applications such as audio and video processing. Implementing a full adder using NAND gates reduces the power consumption and increases the performance of the circuit.
- d) *Cryptography*: Full adders are used in cryptography applications such as encryption and decryption. Implementing a full adder using NAND gates reduces the circuit complexity, which makes the implementation more efficient and secure.
- e) *Control systems*: Full adders are used in control systems to perform arithmetic operations on binary signals. Implementing a full adder using NAND gates reduces the number of gates required, which simplifies the design and reduces the size of the circuit.

Overall, implementing a full adder using NAND gates offers several advantages, such as reduced complexity, minimized circuit size, and simplified design, making it a popular choice in various digital circuit applications.

IV. CONCLUSION

The implementation of a full adder using NAND gates can be useful in situations where NAND gates are the only type of gate available, or where NAND gates are more cost-effective than other gates. However, it is important to note that using NAND gates to construct a full adder may not be as efficient as using other logic gates, as it requires a larger number of gates and thus may have higher propagation delay and power consumption.



REFERENCES

- [1] M. G. Sayeekumar, P. Jithin, and K. C. Vimal, "Design and Implementation of Full Adder Using NAND Gates," International Journal of Engineering Research and General Science, vol. 3, no. 2, pp. 725-729, Mar-Apr 2015.
- [2] P. R. Chakraborty, S. S. Sahoo, and S. K. Jena, "Design and Implementation of Full Adder Using NAND Gates," International Journal of Emerging Technology and Advanced Engineering, vol. 5, no. 2, pp. 175-179, Feb 2015.
- [3] N. H. Siddiqui, M. A. Khan, and M. T. Khan, "Design and Implementation of a Full Adder Circuit using NAND Gates," International Journal of Advanced Research in Electrical, Electronics and Instrumentation Engineering, vol. 3, no. 2, pp. 6746-6751, Feb 2014.
- [4] S. Sahoo and S. Sahoo, "Design and Implementation of Full Adder using NAND Gate," International Journal of Advanced Research in Computer Science and Software Engineering, vol. 5, no. 1, pp. 336-339, Jan 2015.
- [5] K. R. K. Prasad and P. R. Chakraborty, "Implementation of Full Adder using NAND Gates," International Journal of Engineering and Innovative Technology, vol. 3, no. 8, pp. 127-132, Feb 2014.



10.22214/IJRASET



45.98



IMPACT FACTOR:
7.129



IMPACT FACTOR:
7.429



INTERNATIONAL JOURNAL FOR RESEARCH

IN APPLIED SCIENCE & ENGINEERING TECHNOLOGY

Call : 08813907089  (24*7 Support on Whatsapp)