

# Implementation of Wavelet Based Robust Differential Control for Electric Vehicle Application

J.L. Febin Daya, P.Sanjeevikumar, *Senior Member, IEEE*, Frede Blaabjerg, *Fellow, IEEE*,  
Patrick W.Wheeler, *Senior Member, IEEE*, Joseph Olorunfemi Ojo, *fellow, IEEE*

**Abstract:** This research article presents the modeling and simulation of electronic differential, employing a novel wavelet controller for two brushless DC motors. The proposed controller uses discrete wavelet transform to decompose the error between actual and reference speed. Error signal which is actually given by the electronic differential based on throttle and steering angle is decomposed into frequency components. Numerical simulation results are provided for both wavelet and PID controllers. In comparison the proposed wavelet control technique provides greater stability and ensures smooth control of the two back driving wheels.

**Keywords:** Brushless dc motor, Wavelet transforms, Fuzzy logic, PID controllers, Indirect field oriented control, Electrical Vehicles.

**Introduction:** Increasing demand on automobiles, the need for vehicle safety on the road too becomes a major concern. Differential system plays an important role to prevent slipping of vehicles on curved roads. Mechanical differentials are heavy and bulky, not suitable for electric vehicles. Electronic differential constitutes a technological advance in electric vehicle design, enabling better stability and control of the vehicle on curved roads. Neighbourhood Electric Vehicles (NEV) is at present the best solution for personal transportation to keep air quality and traffic problems in check. NEV implementation with two independent wheel drives using induction motors, where the current and speed controllers of which were Proportional-Integral-Derivate (PID) compensators [1]. But PID controller is not robust, need to be tuned for its gain parameters at each operating conditions. Recently, PID controllers are replaced by discrete wavelet transform, thanks to the technology for its robustness [2-8]. Wavelet transforms found applications in ac drives, where pulse-width modulations are carried for single-phase inverter (dc-ac) and three-phase rectifier

30 (ac-dc), shown better performance with experimental implementation than standard PWM techniques [2-4].  
 31 Further, wavelet transform techniques are extended to ac motor applications [5] in particular to electrical  
 32 vehicles (EV). Fuzzy-neural control wavelet algorithms are implemented for steering control of electrical  
 33 vehicles (ac motor drives) [6], also applied successfully for energy management system in plug-in hybrid  
 34 electric vehicles (HEV) [7]. Exploiting the advantages of wavelet technology, this work involved the  
 35 modelling and simulation of an electronic differential with a novel wavelet controller for two brushless DC  
 36 motors, which is yet not proposed by the research articles.

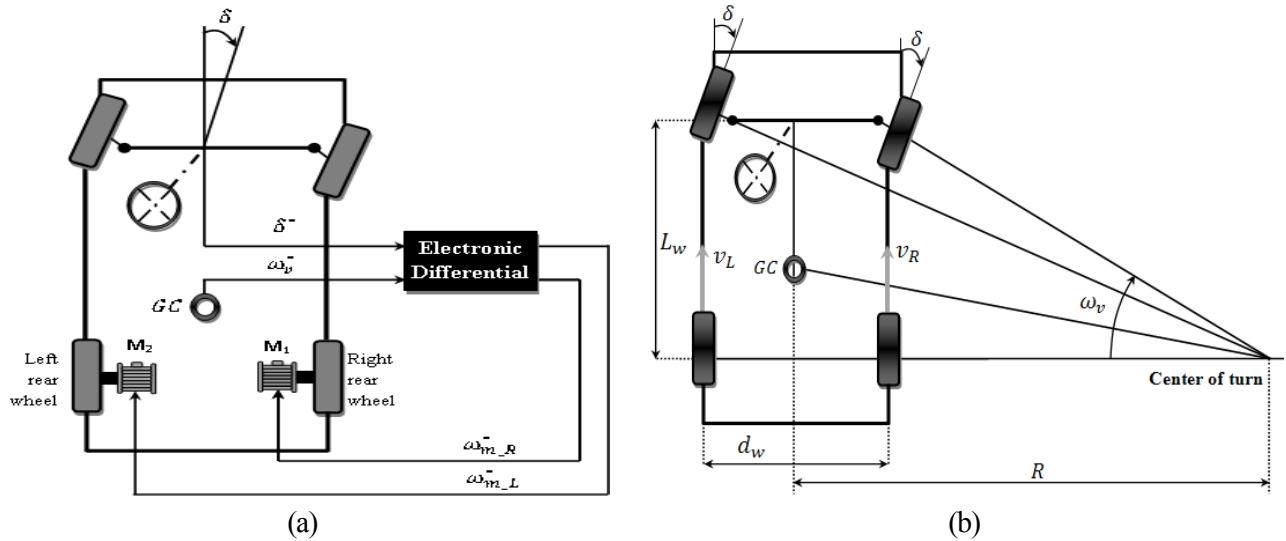

**Fig. 1.** (a) Proposed electronic differential structure, (b) Model of the vehicle driven during a curve.

37  
 38

39 **System Modelling of Electronic Differential:** Fig. 1(a) depicts the proposed electronic differential  
 40 structure, where the left and rights wheels are controlled using two separate motors. BLDC motors are  
 41 preferred due to high efficiency, high torque density, silent operation and low maintenance favours the  
 42 electric vehicle application. Two inputs the steering angle and throttle position collectively decide the speeds  
 43 of the right and the left wheel in order to prevent the vehicle from slipping. For a right turn, the differential  
 44 has to maintain a higher speed at the left wheel than the right wheel to prevent the tyres from losing traction  
 45 while turning. Fig. 1(b) depicts the vehicle during a turn.  $L_w$  is the wheel base,  $\delta$  is the turning angle,  $d_w$  is  
 46 the track width,  $R$  is the radius of the turn and  $\omega_R$  and  $\omega_L$  represent the angular speeds of the left and the right  
 47 wheel respectively. The linear speed of each wheel can be represented as a function of the vehicle speed and  
 48 the radius of the turn as:

$$v_L = \omega_v \left( R + \frac{d_w}{2} \right) \& v_R = \omega_v \left( R - \frac{d_w}{2} \right) \quad (1)$$

49 The relation between the radius of the turn and steering angle and wheel base is:

$$R = \frac{L_w}{\tan \delta} \quad (2)$$

50 Substituting (2) in (1), we get angular speed of each wheel as:

$$\omega_{rL} = \frac{L_w + \frac{1}{2}d_w \tan \delta}{L_w} \omega_v \& \omega_{rR} = \frac{L_w - \frac{1}{2}d_w \tan \delta}{L_w} \omega_v \quad (3)$$

51 The difference between the angular speeds of the wheel drives can be expressed as:

$$\Delta\omega = \omega_{rL} - \omega_{rR} = \frac{d_w \tan \delta}{L_w} \omega_v \quad (4)$$

52 The sign of the steering angle indicates the direction of the turn  $\delta > 0$  = Turn Right,  $\delta < 0$  = Turn left,  $\delta = 0$  =  
 53 Straight Ahead. When the steering input is given by the driver, the electronic differential immediately acts  
 54 by reducing the speed of the inner wheel and increasing the speed of the outer wheel. The driving speeds of  
 55 the wheels are:

$$\omega_{rL}^* = \omega_v + \frac{\Delta\omega}{2} \& \omega_{rR}^* = \omega_v - \frac{\Delta\omega}{2} \quad (5)$$

56

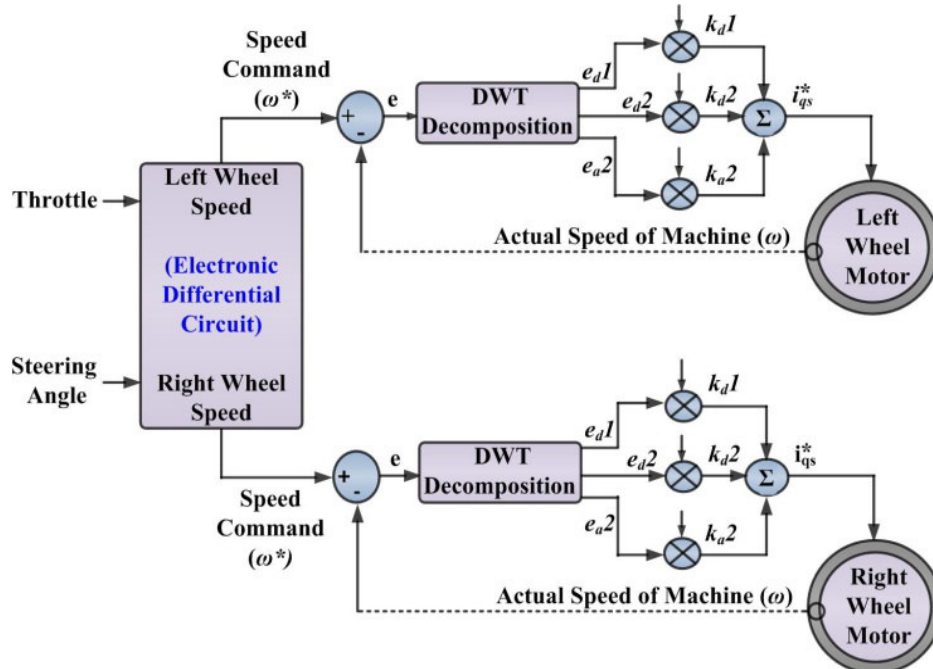

**Fig. 2.** Schematic circuit of proposed novel wavelet based indirect field oriented controller (IFOC) for electronic differential of two brush-less dc (BLDC) motors.

57

58

59 **Discrete Wavelet Controller:** Fig. 2 shows the overall schematic of the wavelet based speed controller of  
60 two brushless DC motor drives. The throttle position and the steering angle were given (7)input for the  
61 electronic differential which generates the desired speed for the left motor and the right motor. The error  
62 detector compares the desired speed and actual speed and generates the error speed which will be used by  
63 the wavelet controllers to generate the control signal for the drive system. The control component generated  
64 by the wavelet controllers are used to drive the two indirect field oriented control (IFOC) BLDC motor  
65 (two).

66 Resolution of DWT begins when a discrete signal  $x[n]$  of length  $N$  is passed through a high pass filter  
67 resulting in an impulse response  $h[n]$  and through a low pass filter resulting in an impulse  $g[n]$ . One level of  
68 DWT is constituted by the outputs of high and low pass filter can be mathematically expressed as [5, 8-9]:

$$d^1[n] = \sum_{k=0}^{N-1} x[k]h[n-k]; a^1[n] = \sum_{k=0}^{N-1} x[k]g[n-k] \quad (6)$$

69 where,  $d^1[n]$  and  $a^1[n]$  are the outputs of the high and low pass filters. After this again the output from the  
70 low pass filter is down sampled by two and again passed through a low and a high pass filter resembling the  
71 ones in the first level and expressed as (second level of decomposition) [5, 8]:

$$d^2[n] = \sum_{k=0}^{N/2-1} a^1[k]h[n-k]; a^2[n] = \sum_{k=0}^{N/2-1} a^1[k]g[n-k] \quad (7)$$

72 Several types of wavelet filters available, the minimum description length (MDL) criterion select the best  
73 and mathematically expressed as:

$$MDL(k, n) = \min \left\{ \frac{3}{2} k \log N + \frac{N}{2} \log \left\| \widetilde{\alpha}_n - \alpha_n^{(k)} \right\|^2 \right\}, \quad (8)$$

$$0 < k < N; 1 \leq n \leq M$$

74 where,  $\widetilde{\alpha}_n = W_n f$  denotes a vector of the wavelet transformed coefficients of the signal  $f$  using wavelet  
75 filters ( $n$ ).  $\alpha_n^{(k)} = \Phi^k \widetilde{\alpha}_n = \Phi^k (W_n f)$  denotes a vector that contains  $k$  non-zero elements. The threshold  
76 parameter  $\Phi^k$  keeps  $k$  number of the largest elements of the vector  $\widetilde{\alpha}_n$  constant and sets all other elements to  
77 zero.  $N$  and  $M$  denote the length of the signal and the number of wavelet filters, respectively. The entropy  
78  $H(x)$  of a signal  $x[n]$  of length  $N$  is defined as:

$$H(x) = - \sum_{n=0}^{N-1} |x(n)|^2 \log |x(n)|^2 \quad (9)$$

79 For determining the optimal levels of decomposition, the entropy is evaluated at each level. For a new  
80 level  $j$ , if:

$$H(x)_j \geq H(x)_{j-1} \quad (10)$$

81 Two levels of decomposition sufficient for effective representation of the error signal. The components  
82 (low/high frequency components) were scaled by their respective gains and then added together to generate  
83 the control signal  $u$ :

$$u = k_{d^1}e_{d^1} + k_{d^2}e_{d^2} + \dots + k_{d^N}e_{d^N} + k_{a^N}e_{a^N} \quad (11)$$

84 where, gains  $k_{d^1}, k_{d^2}, \dots, k_{d^N}$  are used to tune the high and medium frequency components of the error  
85 signal ( $e_{d^1}, e_{d^2}, \dots, e_{d^N}$ ). Gain  $k_{a^N}$  is used to tune the low frequency components of the error signal ( $e_{a^N}$ )  
86 and  $N$  is the number of decomposition levels.

87 **Numerical Simulation Results:** To illustrate the wavelet controller performances, the parameters of the two  
88 identical BLDC are taken with 2hp, 460V, 60Hz, 1750rpm rating, PWM sampling time of 0.5 $\mu$ sec. First  
89 investigation test typically designed and framed for straight road followed by a curved road on the right  
90 (clockwise) at a constant speed of 60km/hr. During the turn, the speeds of the wheels change according to  
91 the command of the electronic differential. For this purposes, the amplitudes and respective time of the  
92 speed and steering angle inputs are as given by Table I.

93 TABLE I. INVESTIGATION DESIGN CRITERION FOR TEST-1.

	Time Vector (Sec)	Amplitude(km/hr) and Angle (deg)
Speed Input	[0 0.2 0.3]	[60 60 60]
Steering Angle Input	[0 0.2 0.3]	[0° 30° 30°]

94

95 It is observed from the test results of Fig.3 (PID controller) and Fig.4 (Wavelet controller), that wavelet  
96 controller based electronic differential offers smooth performance compared to conventional PID Controller.  
97 Moreover, the wavelet based electronic differential offers lesser overshoot (60.09km/hr) and settles quickly  
98 (0.05sec) when compared to PID controller electronic differential (63km/hr, 0.09sec). Therefore, the left and  
99 the right motors produced smooth control with better turning performance of the electric vehicle.

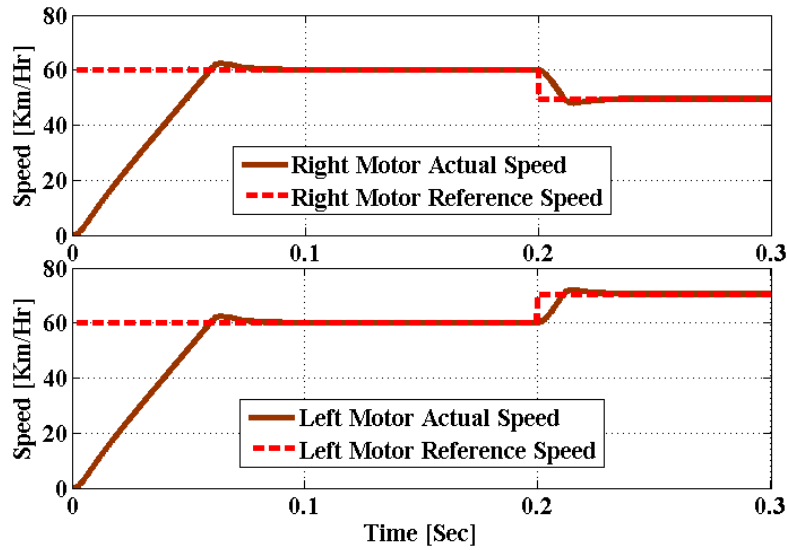

100  
101 **Fig. 3.** Numerical simulation output response behaviour of BLDC motors by the PID controller  
102 (Investigation Test-1). **Top:** Motor 1, **Bottom:** Motor 2.  
103

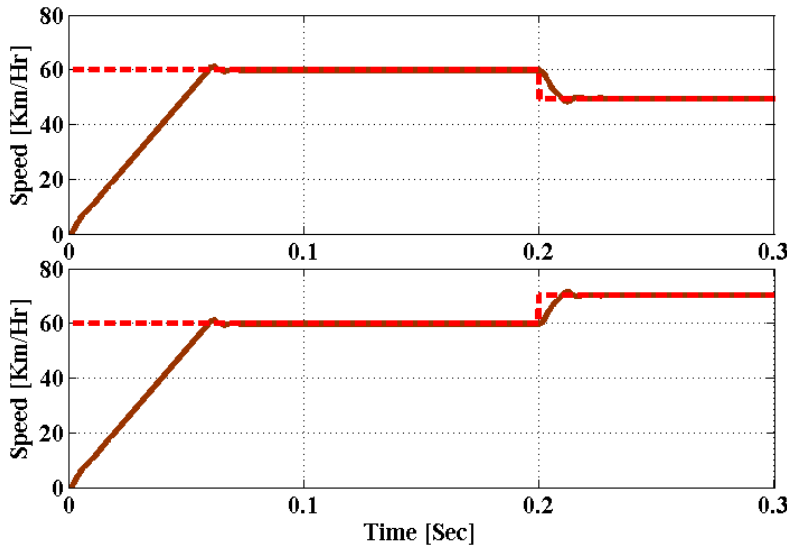

104  
105 **Fig. 4.** Numerical simulation output response behaviour of BLDC motors by the wavelet controller  
106 (Investigation Test-1). **Top:** Motor 1, **Bottom:** Motor 2.  
107

108 Second investigation test typically designed for straight road with a constant speed of 60km/hr., followed by  
109 a right turn ( $30^0$ ) at 30km/hr.; followed by a straight road at a constant speed of 60km/hr as given by Table  
110 II.

111 TABLE II. INVESTIGATION DESIGN CRITERION FOR TEST-2.

	Time Vector (Sec)	Amplitude(km/hr) and Angle (Deg)
Speed Input	[ 0.3 0.4 0.6 0.7 ]	[60 30 60 60]
Steering Angle Input	[ 0.3 0.4 0.6 0.7 ]	[0° 30° 0° 0°]

113 Fig. 5 (PID controller) and Fig. 6 (Wavelet controller) shows the response behaviour of two BLDC motor.  
 114 It observed the peak overshoot with the PID controller is 63km/hr whereas with the wavelet controller, it is  
 115 60.09km/hr. Where the desired speed though is 60 km/hr. and obtained settling time with the PID controller  
 116 is 0.09sec whereas with the wavelet controller, it is 0.05sec.  
 117

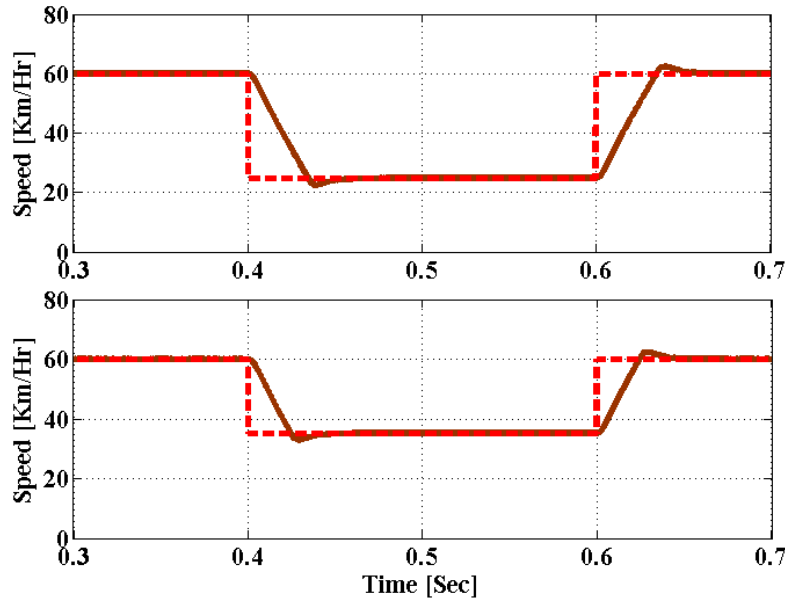

118  
 119 **Fig. 5.** Numerical simulation output response behaviour of BLDC motors by the PID controller  
 120 (Investigation Test-2). **Top:** Motor 1, **Bottom:** Motor 2.  
 121

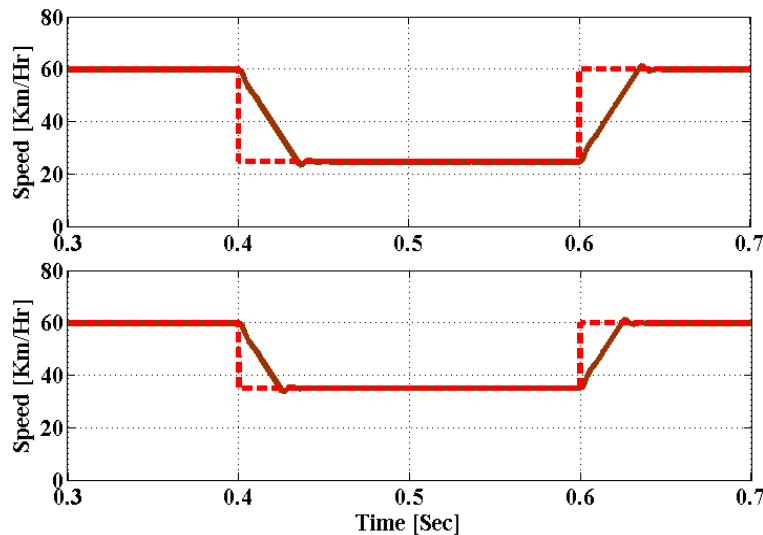

122  
 123 **Fig. 6.** Numerical simulation output response behaviour of BLDC motors by the wavelet controller  
 124 (Investigation Test-2). **Top:** Motor 1, **Bottom:** Motor 2.  
 125

126  
 127 Finally, the performances by wavelet controller are robust due to its discrete transform provides  
 128 approximation and detail coefficients. Approximation coefficients ( $k_{aN}$ ) are the low frequency components

129 responsible for controller functioning i.e lesser this gain value, the lesser the peak overshoot. But the  
130 detailed coefficients ( $k_{d^1}, k_{d^2} \dots k_{d^N}$ ) are the high frequency components responsible for controlling the  
131 noise signals and doesn't affect the output speed performances under ideal noise free condition [9].

132

133 **Conclusion:** This article presented an electronic differential control for electrical vehicle utilizing a novel  
134 wavelet based speed controller. The proposed electric vehicle with two BLDC systems was implemented in  
135 numerical simulation software and the performances are compared with PID controller. Further, it has been  
136 confirmed that wavelet controller provides smooth control due to decreased peak overshoot and reduced  
137 settling time. Hence, the proposed wavelet controller performances are superior and suits electrical vehicle  
138 application in particular to curved roads transportation.

139 Further, real time implementation of proposed complete two motor ac drives system with wavelet controller  
140 using digital signal processor (dsp) is actually under construction. This research article keeps further  
141 investigations under studies, in particular with single wavelet IFOC controller algorithm for multi BLDC  
142 motors (more than two motors) driven with single and/or multiple inverter drive system for future  
143 publications.

144

## 145 **References**

- 146 [1] A. Draou, "Electronic differential speed control for two in-wheels motors drive vehicle", in *Proc. IEEE*  
147 *4<sup>th</sup> Intl. Conf. Power Engg. Energy Elect. Drives, IEEE-POWERENG'13*, Istanbul, Turkey, pp. 764-  
148 769, 13-17 May 2013.
- 149 [2] S.A.Saleh, M.Azizur Rahman, "Experimental Performances of the Single-Phase Wavelet-Modulated  
150 Inverter", in *IEEE Trans. on Power Electron.*, vol. 36, no. 9, pp. 2650-2661, Sept. 2011.
- 151 [3] S.A.Saleh, "The Implementation and Performance Evaluation of  $3\Phi$  VS Wavelet Modulated AC-DC  
152 Converters", in *IEEE Trans. on Power Electron.*, vol. 28, no. 3, pp. 1096-1106, March 2013.
- 153 [4] D. Gonzalez, J. T. Bialasiewicz, J. Balcells, J. Gago, "Wavelet based performance evaluation of power  
154 converters operating with modulated switching frequency", in *IEEE Trans. Ind. Electron.*, vol. 55, no.  
155 8, pp. 3167-3176, Aug. 2008.



- 156 [5] M.A.S.K.Khan, M.A.Rahman, “Implementation of a new wavelet controller for interior permanent  
157 magnet motor drives”, in *IEEE Trans. Ind. Appl.*, vo. 44, pp. 1957–1965, 2008.
- 158 [6] Y-C.Hung, F-J.Lin, J-C.Hwang, J-K.Chang, K-C,Ruan, “Wavelet Fuzzy Neural Network With  
159 Asymmetric Membership Function Controller for Electric Power Steering System via Improved  
160 Differential Evolution”, in *IEEE Trans. on Power Electron.*, vol. 38, no. 4, pp. 2350-2362, April 2014.
- 161 [7] C.Sun, S.J.Moura, X.Hu, J.K.Hedrick, F.Sun, “Dynamic Traffic Feedback Data Enabled Energy  
162 Management in Plug-in Hybrid Electric Vehicles”, in *IEEE Trans. on Power Electron.*, vol. 23, no. 3,  
163 pp. 1075-1086 May 2015.
- 164 [8] S. G. Mallat, “A theory for multi-resolution signal decomposition: The wavelet representation,” in  
165 *IEEE Trans. Pattern Anal. Mach. Intell.*, vol. 11, no. 7, pp. 674–693, Jul. 1989.
- 166 [9] L. Coppola, L. Qian, S. Buso, D. Boroyevich, A. Bell, “Wavelet transform as an alternative to the short-  
167 time Fourier transform for the study of conducted noise in power electronics”, in *IEEE Trans. Ind.*  
168 *Electron.*, vol. 55, no. 2, pp. 880–887, Feb. 2008.

169  
170