

WHOI-89-46
IMET TR-89-03

**Improved Meteorological Measurements
from Buoys and Ships (IMET):
Preliminary Comparison of Solar Radiation
Air Temperature Shields**

by

Gennaro H. Crescenti, Richard E. Payne and Robert A. Weller

Woods Hole Oceanographic Institution
Woods Hole, Massachusetts 02543

October 1989

Technical Report

Funding was provided by the National Science Foundation under
Grant No. OCE-87-09614

Reproduction in whole or in part is permitted for any purpose of the
United States Government. This report should be cited as:
Woods Hole Oceanog. Inst. Tech. Rept., WHOI-89-46, IMET TR-89-03.

Approved for publication; distribution unlimited.

Approved for Distribution:

Robert C Beardsley

Robert C. Beardsley, Chairman
Department of Physical Oceanography



Abstract

Several different types of solar radiation air temperature shields are evaluated for use at sea on ships and buoys. They include three types of static or Thaller shields, two vane oriented shields, and two fan ventilated shields. A preliminary data analysis is presented and discussed.

Table of Contents

1	Introduction	3
2	Description of Radiation Shields	3
2.1	Static Shields	3
2.2	Vane-Oriented Shields	4
2.3	Forced Ventilation	5
3	Data	5
4	Analysis	7
4.1	Plastic Multi-Plate vs. Plastic Multi-Plate	7
4.2	Plastic Multi-Plate vs. Aluminum Multi-Plate	8
4.3	Comparison of All Shields	9
5	Summary and Conclusions	10
	Acknowledgements	12
	References	13
	Appendix A — Manufacturer Addresses	15
	Tables	16
	Figures	38

1 Introduction

Several components of the U.S. effort in the World Ocean Circulation Experiment (WOCE) will require observations of air-sea heat and momentum fluxes from both ships and buoys. A group at the Woods Hole Oceanographic Institution (WHOI) is developing instrumentation to provide Improved Meteorological measurements (IMET) to meet the requirements of these WOCE components. Here we report on one part of our sensor investigations.

The problems of measuring true ambient air temperature (and true ambient relative humidity) have long been recognized (e.g., Franssila, 1961; Pech, 1964; MacHattie, 1965; Fuchs and Tanner, 1965; Hadlock *et al.*, 1972; Sparks, 1972; McKay and McTaggart-Cowan, 1977). The problem is to protect the sensor completely from solar radiation while allowing sufficient ventilation for the sensor to remain at ambient air temperature. Two approaches have been taken toward providing the ventilation: natural (wind) and forced (fan). Each has its limitations. On a calm sunny day a naturally ventilated shield will not be ventilated sufficiently and its internal temperature will rise no matter how good the shielding is. Ventilation by a fan requires too much power to be used on buoys.

2 Description of Radiation Shields

The types of shields investigated thus far are:

Natural ventilation

- Static — Three types of Thaller shields differing in construction details.
- Vane-oriented — Two types differing in materials and dimensions.

Forced ventilation

- Two types of fan-ventilated shields.

2.1 Static Shields

All three static shields have evolved from a design by Gill (1979) for the National Data Buoy Center. The original specifications called for a shield which would be effective, rugged, and compact. Previous studies (Payne, 1987; 1988) have showed that this type of shield is

effective at wind speeds above about 2 m s^{-1} . Intuitively one would expect the positive temperature bias to increase with increasing irradiance and to decrease with increasing wind speed. The previous investigation (Payne, 1987) showed that the wind speed effect was probably weak but, because of the high correlation between solar radiation and wind speed in the sea breeze-dominated local meteorology, the two effects could not be separated quantitatively.

The R. M. Young Gill multi-plate radiation shield (model 41002) comprises a stack of twelve opaque white injection molded plastic plates (Figure 1). R. M. Young states that with maximum solar radiation, the root mean square errors are 0.4°C at 3 m s^{-1} , 0.7°C at 2 m s^{-1} , and 1.5°C at 1 m s^{-1} . Two types were tested. Early models mounted directly above the supporting surface. Recently R. M. Young has changed to an offset mount.

A shield of similar design, but with nine plates of 0.8 mm thick aluminum, pressure formed, and painted with white Imron, has been developed at WHOI by J. Dean. This shield has been used on some previous buoy deployments (Dean and Beardsley, 1988).

A plastic Gill multi-plate shield was modified during testing by removing the top plate of the shield and replacing it with a solar powered fan.

2.2 Vane-Oriented Shields

Vane-oriented shields are being considered as an alternative to static radiation shields. In general, a vane-oriented shield consists of two or more concentric tubes oriented by a tail fin to face the wind at all times when the wind is strong enough to overcome the bearing friction. The temperature sensor is located at the center of the innermost tube. Even in light wind conditions, the motion of the buoy may be sufficient to allow some ventilation.

Two vane-oriented shields are currently under test. The Met One vane radiation shield (model 071A) is constructed of two concentric aluminum tubes (Figure 2). The outer tube has a 76 mm diameter and is painted with a high gloss white enamel. The vane rotates on two sealed ball bearings and is oriented into the wind by a large tail fin. Past tests have shown that the ball bearings used by the manufacturer corrode in a salt environment. They are probably insufficiently protected to provide reliable operation at sea.

A prototype shield developed at WHOI by J. Dean has undergone several engineering modifications since Payne's (1987) test (Figure 3). Similar in design to the Met One, it is constructed of three concentric plastic tubes but has a smaller tail fin. The outer tube is 89 mm diameter, is approximately 50 cm long, and is painted with white enamel.

2.3 Forced Ventilation

Radiation shields that use fans for ventilation are being considered for use on ships where power limitations are not as restrictive as on a buoy. A fan constantly draws in ambient air through several concentric, usually vertically oriented, tubes. In general, higher ventilation rates keep the air temperature inside the shield closer to ambient.

The Met One radiation shield (model 076) draws in ambient air at approximately 2.5 m s^{-1} through the bottom of three concentric aluminum cylinders and is exhausted at the top of the shield (Figure 4). The outside tube is approximately 89 mm in diameter and is painted with a white enamel.

An R. M. Young Gill Aspirated radiation shield (model 43404) was included for comparison purposes only (Figure 5). This model is obsolete but has been included in past studies (e.g., Payne, 1987). The temperature sensor is mounted inside a vertically-oriented double-walled evacuated silvered glass cylinder. A fan draws in ambient air through the bottom of the tube past the sensor at a rate of approximately 3 m s^{-1} . A prototype of a new ventilated shield by R. M. Young is now being tested.

Table 1 contains a summary of the manufacturer specifications for these shields.

3 Data

The radiation shields were located on the meteorology tower and on an adjacent aluminum rack on top of the Smith Building of WHOI in Woods Hole, Massachusetts ($41^{\circ}31.5'N$, $70^{\circ}40.0'W$). The building is located on Woods Hole Harbor.

Air temperature is measured with standard YSI thermistors (P/N 44032) (Payne, 1974). The thermistors have a nominal resistance of 30.00 kohms at $20^{\circ}C$ and are potted in 1/4 inch stainless steel bolts at the factory (probe style 095). The thermistor and bolt assembly are

then mounted in a protective Delrin cylinder at WHOI. There is approximately 1.6 mm of plastic between the bolt and ambient air.

The thermistors are calibrated to an accuracy of 0.01°C absolute (Payne *et al.*, 1976) at a WHOI calibration facility before each deployment or test. Thermistor drifts are typically less than three millidegrees per year. A precision voltage is applied across the thermistor and a fixed resistor in series. The temperature can be calculated from the voltage drop across the thermistor.

The radiation shield performance was studied in three separate tests. The first test was a comparison of air temperature measurements between two identical R. M. Young Gill multi-plate shields. The shields used the old style mounts which positioned the shields directly above the supporting surface and were spaced approximately 0.5 m apart. Data were recorded by a NEC APC-IV 286 computer with an Analog Devices RTI-800, 12-bit, analog-to-digital (A/D) board. Data were sampled once every 30 seconds and were averaged and recorded at 7.5 minute intervals. In addition, insolation values were recorded using an Eppley Precision Spectral Pyranometer (model PSP) and wind speed with an R. M. Young Wind Monitor (model 5103).

The second test was a comparison of air temperature measurements between a plastic multi-plate shield and an aluminum multi-plate shield made at WHOI. For this test, data were obtained by two Vector Averaging Wind Recorders (VAWR) (Payne, 1974) placed on the meteorology tower approximately 2 m apart. The averaging period for these instruments was also 7.5 minutes. Midway through the comparison, the top plate of the plastic shield was removed and replaced with a solar powered fan. Insolation data were recorded using an Eppley Black and White Pyranometer (model 8-48) and wind speed with an aluminum cup anemometer.

The third test was a comparison of all the shields described in section 2. All of these shields were located within about 1 m of each other. These data were recorded on a NEC APC-IV 286 computer with a Metra-Byte DAS-16, 12-bit, A/D board. Data were sampled once every second and running averages were recorded every 7.5 minutes. Insolation was measured by an Eppley PSP and wind speeds by an R. M. Young Propvane.

4 Analysis

4.1 Plastic Multi-Plate vs. Plastic Multi-Plate

Weekly means and standard deviations were computed for each air temperature (WHOI serial numbers YSI-10 and YSI-20) and for the difference (Table 2). The overall mean difference between the two air temperatures is -0.012°C with a standard deviation of 0.074°C . Figure 6a shows the probability density of the difference. Weekly mean differences seldom exceeded 0.03°C .

The means and standard deviations for all nighttime data (insolation values less than 5 Wm^{-2}) are shown in Table 3. The overall mean difference is -0.007°C with a standard deviation of 0.045°C . Weekly means of the difference never exceed 0.02°C . The probability density of all nighttime data (Figure 6b) shows very little spread in the temperature differences. Similarly, the means and standard deviations were computed for all daytime data (insolation values greater than 5 Wm^{-2} , Table 4). The probability density (Figure 6c) shows a slightly larger spread in air temperature difference than these nighttime data with an overall mean air temperature difference is -0.017°C with a standard deviation of 0.096°C . The daytime weekly mean differences seldom exceed 0.05°C .

Table 5 summarizes the mean differences of air temperature for various ranges of wind speed. Table 6 summarizes the frequency distribution of wind speed. An overall mean difference of 0.03°C is found when winds were less than 2 to 3 m s^{-1} for all data. The overall mean difference increases to about 0.6°C for all daytime data (Tables 7 and 8) for the same range of wind speeds. For winds greater than 3 m s^{-1} , the overall mean differences become very small, typically on the order of 0.01 to 0.02°C .

The mean difference in air temperature is small even though differences in individual data records sometimes exceed 0.2°C . The accuracy of the measured air temperature is approximately 0.1°C . This takes into account errors in calibration (and drift) of the thermistors, temperature dependent errors in the A/D board, variations in the precision voltage across the thermistor circuit, and random noise signals (e.g., radio interference). The larger differences, when they do exist, occur when the wind is light and insolation is large.

We assume that differential heating of the meteorology tower and other surrounding fixtures creates these differences.

We conclude that there is no significant difference in measured air temperatures between the two plastic Gill multi-plate shields.

4.2 Plastic Multi-Plate vs. Aluminum Multi-Plate

Weekly means and standard deviations for all data for these two shields appear in Table 9. The overall mean air temperature difference (aluminum-plastic) is -0.021°C with a standard deviation of 0.127°C . Weekly differences sometimes reached 0.10°C but were mostly less than 0.03°C . The probability density of the differences (Figure 7a) is much like the distribution found with the two plastic Gill shields.

The overall mean difference of all nighttime data is -0.018°C with a standard deviation of 0.090°C (Table 10). Most of the weekly mean differences are typically less than 0.05°C . The probability density for these data (Fig. 7b) shows a small spread in temperature differences. The overall mean temperature difference for all daytime data is -0.023°C with a standard deviation of 0.145°C (Table 11). Most of the weekly mean differences are less than 0.05°C but are sometimes as large as 0.15°C .

Mean temperature differences were categorized according to wind speed ranges for all data (Tables 12 and 13) and for all daytime data (Tables 14 and 15). In general, the overall mean differences are less than 0.1°C in both cases, with the largest weekly mean differences occurring at the lowest wind speeds (less than 2 m s^{-1}).

Accuracy of temperature measurements with the VAWR are approximately 0.01°C (Payne, 1974). Like the first comparison, the mean differences are of the same order as the overall system accuracy of the VAWR. Hence, we see no significant difference between the two shields. The standard deviations, however, are slightly larger, indicating more scatter in these data than with the two plastic Gill shields.

The plastic radiation shield was modified part way through VAWR testing. The top plate of the shield was removed and replaced with a solar powered fan to provide additional ventilation.

The overall mean difference is -0.062°C with a standard deviation of 0.154°C (Table 16). For all the weekly mean differences, the newly modified shield had warmer air temperatures ranging from 0.02 to 0.10°C . Figure 8a shows the probability density for these data. Most of the temperature differences occur on the left side of the zero line indicating that the aluminum shield is keeping the air temperature cooler than the plastic shield. The overall mean difference for nighttime data is -0.005°C with a standard deviation of 0.059°C (Table 17). The probability density (Figure 8b) is much like the other evening distributions showing very little scatter. The overall mean difference for the all daytime data is -0.114°C with a standard deviation of 0.168°C (Table 18). The probability density (Figure 8c) shows a large bias towards the left of the zero line indicating that the air temperature in the plastic shield is significantly warmer than in the aluminum shield much of the time. Weekly mean differences exceed 0.15°C .

The solar powered fan was intended to ventilate the shield during the day. However, the solar battery assembly was partially transparent, thus allowing solar energy to be transmitted and absorbed inside the shield. This raised the air temperature. In addition, the overall fan design may not be efficient for ventilating Thaller type shields. The air was probably not being drawn through the entire shield, but rather, through the top several plates just above the probe. Hence, it may not be feasible to ventilate a Thaller type shield in any simple manner.

Tables 19–22 categorize the mean differences into wind speed ranges for all data and for all daytime data. Again, the largest differences are found when winds are less than 2 m s^{-1} . For these daytime data, the overall mean difference approaches 0.2°C .

4.3 Comparison of All Shields

Results from tests of five different shields are examined and discussed in this section. The shields include an R. M. Young Gill multi-plate shield, a Met One and WHOI vane-oriented shield, and an R. M. Young Gill and Met One fan ventilated shield.

The Met One fan ventilated shield was used as a standard for comparison since its air temperature was the lowest. Scatter plots of air temperature difference as a function of insolation for a two week period are shown in Figures 9–12. Linear least square fits were

computed for each scatter plot. Figure 9 shows the difference in air temperature between the R. M. Young Aspirated shield minus the Met One shield. For an insolation of 1000 Wm^{-2} , the linear fit error is 0.48°C . The error for the R. M. Young Gill multi-plate shield is 0.51°C (Figure 10), 0.27°C for the Met One vane (Figure 11), and 0.43°C for the WHOI vane (Figure 12).

Probability density functions were constructed of air temperature difference for six weeks of data. Figure 13a displays the probability density of the R. M. Young Aspirated shield minus the Met One shield. The R. M. Young shield was inferior to the Met One shield (Figure 13c). An error of 0.1 to 0.2°C is most frequently observed but errors of more than 0.5°C are sometimes experienced. A prototype of a new R. M. Young shield is now being tested.

For the R. M. Young Gill multi-plate shield (Figure 14) a temperature error of 0.1 to 0.2°C is frequently observed with occasional errors in excess of 0.5°C due to large solar heating. Agreement at night is very good.

Both vane-oriented shields behave in a similar manner. The Met One vane (Figure 15) and WHOI vane (Figure 16) have errors usually less than 0.5°C . The evening values show offsets to the left side of the graphs, indicating that both of these vanes are observing cooler air temperatures than the Met One shield. This is difficult to explain. One possibility is that heat may be generated by the fan on the Met One shield and is keeping the temperature in the shield slightly warmer or it may just be a bias in the recording system. The errors are evenly distributed on both sides of the zero line within $\pm 0.3^\circ\text{C}$. Of the two vanes, the Met One vane minimizes the solar heating. The WHOI vane has larger errors (greater than 0.5°C) more frequently.

5 Summary and Conclusions

Performance of radiation shields has been examined as part of the IMET project. Static and vane-oriented shields are being considered for use on buoys while fan ventilated shields are being evaluated for use on ships where power is readily available. These shields have been tested and the results are discussed.

The mean difference of air temperatures inside two R. M. Young Gill multi-plate radiation shields is of order 0.01°C . This difference is much less than the accuracy of the data acquisition system. Differences on the order of several tenths of a degree are occasionally observed when winds are light and solar heating large. Differential heating of the meteorology tower is assumed to be the contributing factor. Past studies (Gill, 1983; McKay and McTaggart-Cowan, 1977) have shown that, when compared to other static shields, the Gill multi-plate radiation shield has the best performance.

There is no significant difference between similar Thaller type shields made of plastic and aluminum. The overall mean air temperature difference is approximately 0.02°C which is about one order of magnitude smaller than the accuracy of the recording system. More variability in these data was observed than with two plastic multi-plate shields. It may be advantageous to use the plastic since the aluminum may corrode in the marine environment.

The top plate of a plastic Thaller shield was removed and replaced with a solar powered fan. Data suggest that this design did not work well as heat was transmitted through the top of the battery assembly into the shield. Also, the fan was probably not drawing air through the entire shield, but rather through the top several plates which are above the probe.

The Met One fan ventilated shield was used as a standard to compare the other shields against. An obsolete R. M. Young Aspirated shield was included for comparison purposes only and did not perform as well as the Met One shield.

A vane-oriented shield may be more desirable for use on buoys where power requirements are limited. The preliminary results presented here suggest that a vane may work better than a static shield because of the ability of the vane to orient itself into the wind. However, the mechanical design must be improved (e.g., minimize corrosion effects). Of the two vanes, the Met One shows a slightly better performance. More engineering modifications are anticipated on the WHOI vane.

Acknowledgements

The authors wish to thank Jerome Dean for testing his vane oriented radiation shield. Thanks goes out to Ovid Forier for his help in designing and constructing the circuitry for the data acquisition system. The authors would also like to thank Barbara Gaffron for her helpful suggestions and comments.

This work was funded by the National Science Foundation (Grant OCE-8709614) as a World Ocean Circulation Experiment (WOCE) long-lead time development activity.

References

- Dean, J. P., and R. C. Beardsley, 1988. A vector-averaging wind recorder (VAWR) system for surface meteorological measurements in CODE (Coastal Ocean Dynamics Experiment). Woods Hole Oceanographic Institution Technical Report, *WHOI-88-20*, 74 pp.
- Franssila, M., 1961. Radiation shield for microclimatological measuring of temperature. *Geophysica*, 8, 85-88.
- Fuchs, M., and C. B. Tanner, 1965. Radiation shields for air temperature thermometers. *Journal of Applied Meteorology*, 4, 544-547.
- Gill, G. C., 1979. Development of a small rugged radiation shield for air temperature measurements on drifting buoys. Report on research sponsored by the NOAA Data Buoy Office, Bay St. Louis, Mississippi, 23 pp., 17 figs.
- Gill, G. C., 1983. Comparison testing of selected naturally ventilated solar radiation shields. Report submitted to NOAA Data Buoy Office, Bay St. Louis, Mississippi. In partial fulfillment of Contract #NA-82-0A-A-266, September 1983.
- Hadlock, R., W. R. Seguin, and M. Garstang, 1972. A radiation shield for thermistor deployment in the atmospheric boundary layer. *Journal of Applied Meteorology*, 11, 393-399.
- MacHattie, L. B., 1965. Radiation screens for air temperature measurements. *Ecology*, 46, 533-538.
- McKay, D. J., and J. D. McTaggart-Cowan, 1977. An intercomparison of radiation shields for auto stations. WMO Technical Conference on Instruments and Methods of Observation (TECIMO), Hamburg, *WMO No. 480*, pp. 208-213.
- Payne, R. E., 1974. A buoy-mounted meteorological recording package. Woods Hole Oceanographic Institution Technical Report, *WHOI-74-40*, 32 pp.

Payne, R. E., 1987. Air temperature shield tests. Woods Hole Oceanographic Institution Technical Report, *WHOI-87-40*, 22 pp.

Payne, R. E., 1988. The MR: A meteorological data sensing, recording and telemetering package for use on moored buoys. *Journal of Atmospheric and Oceanic Technology*, **5**, 286-297.

Payne, R. E., A. L. Bradshaw, J. P. Dean, and K. E. Schleicher, 1976. Accuracy of temperature measurements with the VACM. Woods Hole Oceanographic Institution Technical Report, *WHOI-76-94*, 78 pp.

Pech, G., 1964. A practical thermocouple shield. *Forestry Chronicle*, **40**, 184-186.

Sparks, W. R., 1972. The effect of thermometer screen design on the observed temperature. World Meteorological Organization, *WMO No. 315*, 106 pp.

Appendix A — Manufacturer Addresses

Met One, Inc
481 California Avenue
Grants Pass, Oregon 97526
(503) 479-1248
Vane Aspirated Temperature Shield (071A) \$430
Air Temperature Aspirated Radiation Shield (076) \$697

R. M. Young Company
2801 Aero-Park Drive
Traverse City, Michigan 49684
(616) 946-3980
Gill Multi-Plate Radiation Shield (41002) \$158
Gill Aspirated Radiation Shield (43404) Discontinued

Yellow Springs Instrument Company, Inc.
Yellow Springs, Ohio 45387
(513) 767-7241
Precision Thermistor (44032) \$16.20

Table 1: Manufacturer Specifications for Radiation Shields

Manufacturer	Young	Young	Met One	Met One
Model	41002	43404	076	071A
Temperature Error (C)	1.5 @ 1 m s ⁻¹ 0.7 @ 2 m s ⁻¹ 0.4 @ 3 m s ⁻¹	0.2	0.03	0.1 @ > 1.5 m s ⁻¹
Maximum Solar Intensity (Wm ⁻²)	1080	1080	840	1120
Aspiration (m s ⁻¹)	variable	3.0	2.5	variable
Cost	\$158	-	\$697	\$430

Table 2: Comparison of Two Identical Plastic Gill Multi-Plate Shields

All Data							
Date (YYWK)	Recs	Mean			Standard Deviation		
		YSI-10 (C)	YSI-20 (C)	10-20 (C)	YSI-10 (C)	YSI-20 (C)	10-20 (C)
8825	271	15.395	15.393	0.002	1.282	1.276	0.060
8826	622	16.672	16.690	-0.018	1.722	1.738	0.092
8827	476	19.443	19.477	-0.034	1.610	1.606	0.158
8828	1174	21.065	21.063	0.003	1.644	1.647	0.077
8829	1342	21.397	21.414	-0.017	1.637	1.654	0.077
8830	1342	21.582	21.587	-0.005	1.476	1.473	0.055
8831	1339	23.235	23.254	-0.019	1.281	1.279	0.091
8832	1342	23.689	23.690	-0.001	0.999	1.004	0.049
8833	1341	21.472	21.488	-0.016	1.985	1.983	0.058
8834	1338	18.667	18.692	-0.024	2.366	2.372	0.093
8835	1342	20.303	20.324	-0.021	2.123	2.128	0.070
8836	1343	18.506	18.526	-0.019	2.186	2.172	0.103
8837	1344	16.732	16.764	-0.032	2.317	2.296	0.094
8838	487	18.355	18.377	-0.022	1.446	1.470	0.093
8844	450	11.738	11.752	-0.013	2.141	2.155	0.059
8845	1343	10.196	10.209	-0.013	3.077	3.081	0.053
8846	1344	9.345	9.358	-0.013	3.052	3.052	0.051
8847	1344	6.021	6.038	-0.017	3.643	3.635	0.075
8848	1344	7.934	7.954	-0.020	3.414	3.411	0.060
8849	1341	2.851	2.868	-0.017	4.530	4.536	0.047
8850	1344	-2.361	-2.357	-0.004	6.029	6.035	0.058
8851	1343	2.511	2.522	-0.011	4.668	4.676	0.054
8852	1343	2.912	2.924	-0.012	3.867	3.859	0.076
8901	1344	-2.379	-2.360	-0.019	5.134	5.135	0.056
8902	1343	1.920	1.937	-0.017	3.193	3.193	0.051
8903	1344	2.794	2.801	-0.007	3.421	3.402	0.090
8904	1344	1.637	1.657	-0.020	3.558	3.558	0.071
8905	1344	3.102	3.111	-0.009	3.567	3.579	0.059
8906	1344	-3.270	-3.272	0.002	3.195	3.201	0.060
8907	1344	-0.073	-0.069	-0.004	4.575	4.586	0.064
8908	1344	1.115	1.102	0.013	4.598	4.607	0.054
8909	1344	-0.300	-0.290	-0.011	2.156	2.167	0.074
8910	1344	-1.863	-1.877	0.014	3.262	3.259	0.092
8911	1344	3.384	3.390	-0.006	3.129	3.143	0.092
8912	885	1.657	1.652	0.004	2.241	2.257	0.122
Total	41967	8.917	8.929	-0.012	3.252	3.254	0.074

Table 3: Comparison of Two Identical Plastic Gill Multi-Plate Shields

Nighttime Data (less than 5 Wm⁻²)

Date (YYWK)	Recs	Mean			Standard Deviation		
		YSI-10 (C)	YSI-20 (C)	10-20 (C)	YSI-10 (C)	YSI-20 (C)	10-20 (C)
8825	73	13.811	13.809	0.002	0.163	0.162	0.015
8826	242	15.654	15.651	0.003	1.195	1.203	0.028
8827	163	18.536	18.530	0.006	1.315	1.320	0.026
8828	460	19.827	19.817	0.010	0.751	0.753	0.032
8828	549	20.815	20.821	-0.006	1.332	1.326	0.041
8830	550	20.733	20.733	0.001	1.052	1.039	0.036
8831	549	22.463	22.465	-0.002	0.895	0.893	0.027
8832	568	23.097	23.091	0.005	0.660	0.659	0.025
8833	586	21.097	21.091	0.006	2.227	2.227	0.028
8834	602	17.782	17.775	0.007	1.886	1.891	0.027
8835	624	19.639	19.637	0.002	2.060	2.062	0.013
8836	645	17.974	17.977	-0.003	1.937	1.934	0.082
8837	655	16.542	16.538	0.004	2.398	2.395	0.032
8838	277	17.695	17.696	-0.001	0.559	0.555	0.042
8844	247	11.578	11.596	-0.018	2.299	2.292	0.022
8845	787	10.165	10.181	-0.016	3.149	3.150	0.031
8846	806	9.136	9.153	-0.018	3.091	3.091	0.036
8847	820	5.675	5.693	-0.018	4.068	4.064	0.039
8848	839	7.636	7.651	-0.014	3.366	3.365	0.048
8849	825	3.066	3.084	-0.019	4.575	4.577	0.020
8850	835	-2.652	-2.649	-0.003	6.209	6.212	0.050
8851	843	2.282	2.294	-0.012	4.847	4.857	0.040
8852	838	2.966	2.974	-0.008	4.115	4.108	0.073
8901	833	-2.627	-2.619	-0.008	5.243	5.245	0.040
8902	831	1.663	1.679	-0.016	3.391	3.392	0.039
8903	812	2.763	2.776	-0.013	2.646	2.631	0.055
8904	804	0.847	0.862	-0.015	3.853	3.856	0.060
8905	796	3.163	3.170	-0.007	3.268	3.276	0.056
8906	775	-3.716	-3.714	-0.002	3.115	3.122	0.045
8907	762	-0.124	-0.118	-0.006	4.099	4.099	0.037
8908	759	0.925	0.915	0.010	4.174	4.177	0.045
8909	720	-0.690	-0.680	-0.010	2.084	2.085	0.046
8910	709	-2.160	-2.157	-0.003	2.911	2.905	0.050
8911	692	2.726	2.740	-0.014	3.036	3.039	0.052
8912	442	1.236	1.252	-0.016	2.029	2.029	0.059
Total	22318	7.377	7.384	-0.007	3.344	3.345	0.045

Table 4: Comparison of Two Identical Plastic Gill Multi-Plate Shields

Daytime Data (Greater than 5 Wm⁻²)

Date (YYWK)	Recs	Mean			Standard Deviation		
		YSI-10 (C)	YSI-20 (C)	10-20 (C)	YSI-10 (C)	YSI-20 (C)	10-20 (C)
8825	198	15.979	5.977	0.002	0.985	0.975	0.069
8826	380	17.321	17.352	-0.032	1.693	1.703	0.114
8827	313	19.916	19.971	-0.055	1.547	1.520	0.191
8828	714	21.863	21.865	-0.002	1.568	1.567	0.095
8828	793	21.801	21.825	-0.024	1.707	1.733	0.094
8830	792	22.171	22.180	-0.009	1.441	1.439	0.065
8831	790	23.771	23.802	-0.031	1.235	1.219	0.115
8832	774	24.123	24.128	-0.005	0.982	0.988	0.061
8833	755	21.763	21.797	-0.034	1.721	1.710	0.068
8834	736	19.392	19.441	-0.050	2.471	2.462	0.117
8835	718	20.880	20.922	-0.041	2.006	2.002	0.090
8836	698	18.998	19.032	-0.035	2.287	2.257	0.117
8837	689	16.913	16.979	-0.066	2.223	2.177	0.118
8838	210	19.226	19.275	-0.050	1.763	1.786	0.127
8844	203	11.934	11.941	-0.008	1.920	1.964	0.085
8845	556	10.239	10.248	-0.009	2.975	2.983	0.073
8846	538	9.659	9.665	-0.006	2.966	2.968	0.067
8847	524	6.561	6.577	-0.016	2.772	2.756	0.110
8848	505	8.429	8.459	-0.030	3.440	3.429	0.076
8849	516	2.507	2.522	-0.015	4.439	4.453	0.072
8850	509	-1.884	-1.877	-0.007	5.695	5.705	0.070
8851	500	2.895	2.905	-0.010	4.326	4.331	0.071
8852	505	2.821	2.841	-0.020	3.417	3.408	0.080
8901	511	-1.974	-1.937	-0.037	4.930	4.927	0.073
8902	512	2.338	2.356	-0.018	2.795	2.795	0.066
8903	532	2.841	2.840	0.001	4.348	4.323	0.126
8904	540	2.813	2.840	-0.027	2.668	2.653	0.085
8905	548	3.014	3.026	-0.012	3.962	3.981	0.063
8906	569	-2.663	-2.670	0.008	3.205	3.213	0.076
8907	582	-0.007	-0.006	-0.001	5.134	5.157	0.087
8908	585	1.362	1.345	0.018	5.088	5.105	0.065
8909	624	0.150	0.162	-0.012	2.152	2.173	0.097
8910	635	-1.531	-1.564	0.033	3.588	3.590	0.120
8911	652	4.082	4.080	0.002	3.076	3.106	0.120
8912	443	2.027	2.052	0.025	2.362	2.401	0.159
Total	19649	10.666	10.683	-0.017	3.060	3.062	0.096

**Table 5: Mean Differences of Two Identical Plastic
Gill Multi-Plate Shields by Wind Speed
(YSI-10-YSI-20) All Data**

Date (YYWK)	0-1 m s ⁻¹	1-2 m s ⁻¹	2-3 m s ⁻¹	3-4 m s ⁻¹	4-5 m s ⁻¹	5-6 m s ⁻¹	6-7 m s ⁻¹	7-8 m s ⁻¹	>8 m s ⁻¹
8825	-0.002	-0.006	-0.012	-0.007	0.007	0.037	0.017	0.010	0.013
8826	-0.200	-0.071	-0.026	0.017	-0.008	-0.010	-0.013	-0.003	-0.011
8827	-0.309	-0.106	-0.109	-0.037	0.003	-0.007	-0.055	-0.013	0.025
8828	0.063	0.002	0.014	0.022	-0.016	-0.002	-0.012	0.002	-0.000
8829	-0.039	-0.068	-0.033	-0.004	-0.003	0.003	-0.008	0.008	0.008
8830	-0.057	-0.021	-0.008	-0.001	0.007	0.005	0.003	-0.002	0.005
8831	-0.025	-0.032	-0.025	-0.036	-0.029	-0.023	-0.008	0.005	0.012
8832	-0.138	-0.076	-0.020	-0.000	0.002	0.003	0.004	0.012	0.013
8833	-0.066	-0.032	-0.023	-0.028	-0.012	-0.013	-0.020	-0.009	0.002
8834	-0.045	-0.040	-0.048	-0.023	-0.011	0.000	0.008	-0.001	0.019
8835	-0.005	-0.027	-0.040	-0.025	-0.030	-0.011	-0.001	-0.005	0.005
8836	0.012	-0.082	-0.030	-0.011	-0.012	-0.027	-0.038	-0.005	0.006
8837	0.051	-0.095	-0.051	-0.074	-0.038	-0.011	0.006	0.000	-0.005
8838	-0.002	-0.079	-0.021	-0.018	-0.013	-0.005	-0.006	-0.013	0.001
8844	0.029	0.074	-0.018	-0.043	-0.033	-0.023	-0.010	-0.007	0.023
8845	-0.005	0.007	0.009	-0.013	-0.012	-0.021	-0.012	-0.032	-0.018
8846	-0.032	-0.004	0.008	0.003	-0.029	-0.012	-0.010	-0.016	-0.025
8847	-0.059	-0.045	-0.003	-0.022	-0.017	-0.013	-0.003	0.020	-0.010
8848	-0.060	-0.087	-0.051	-0.008	-0.006	-0.013	-0.021	-0.028	-0.016
8849	-	0.015	-0.001	-0.012	-0.018	-0.022	-0.009	-0.014	-0.027
8850	-0.031	0.013	0.019	0.007	0.004	-0.007	-0.012	-0.010	-0.008
8851	-	-0.007	0.011	-0.018	-0.022	-0.011	-0.014	-0.003	-0.011
8852	-	-	0.051	-0.006	-0.009	-0.020	-0.007	-0.025	-0.011
8901	-	-	-0.023	-0.019	-0.041	-0.015	-0.013	-0.009	-0.023
8902	-	-0.005	-0.005	0.005	-0.007	-0.011	-0.016	-0.015	-0.023
8903	-	-0.044	-0.027	-0.006	-0.003	-0.009	-0.029	-0.027	0.005
8904	-0.028	-0.037	-0.012	-0.017	-0.013	-0.014	-0.020	-0.018	-0.022
8905	-0.002	-0.007	-0.005	-0.001	-0.009	-0.007	-0.015	-0.017	-0.014
8906	-0.000	0.008	0.008	0.008	0.008	0.003	-0.001	0.006	-0.006
8907	-	-0.018	-0.002	-0.001	-0.014	0.006	0.009	-0.002	-0.022
8908	0.022	-0.002	-0.007	0.017	0.031	0.015	0.006	0.008	0.013
8909	0.010	-0.026	-0.014	-0.020	-0.013	0.004	0.002	-0.007	-0.009
8910	0.019	0.020	0.272	0.100	0.073	0.022	0.013	0.020	0.007
8911	0.010	0.014	-0.022	-0.012	0.005	0.005	-0.001	-0.010	-0.007
8912	-	0.210	0.062	0.025	0.012	0.008	0.000	-0.009	0.002
Total	-0.033	-0.032	-0.018	-0.013	-0.010	-0.007	-0.008	-0.007	-0.008

Table 6: Wind Speed Distribution

All Data

Date (YYWK)	0-1 m s ⁻¹	1-2 m s ⁻¹	2-3 m s ⁻¹	3-4 m s ⁻¹	4-5 m s ⁻¹	5-6 m s ⁻¹	6-7 m s ⁻¹	7-8 m s ⁻¹	>8 m s ⁻¹	Total
8825	11	57	33	65	50	26	14	10	5	271
8826	6	90	124	126	86	63	63	48	16	622
8827	4	35	51	52	84	110	63	44	33	476
8828	19	122	182	170	196	194	133	104	54	1174
8829	7	188	257	238	205	165	107	84	91	1342
8830	47	188	277	253	187	168	127	73	22	1342
8831	59	173	183	148	185	205	120	101	165	1339
8832	2	61	90	169	217	265	233	145	160	1342
8833	29	143	164	203	150	131	129	68	324	1341
8834	42	218	306	292	170	132	85	50	43	1338
8835	12	193	270	244	171	111	145	91	105	1342
8836	9	93	213	238	175	136	122	111	246	1343
8837	5	25	103	264	338	264	129	58	158	1344
8838	7	74	68	105	39	57	46	43	48	487
8844	8	25	37	66	109	77	47	22	59	450
8845	12	91	112	135	212	196	158	99	328	1343
8846	21	122	118	144	130	182	170	160	297	1344
8847	51	142	111	238	285	167	74	56	220	1344
8848	1	33	53	83	85	152	190	200	547	1344
8849	0	21	122	151	160	191	149	99	448	1341
8850	3	24	74	107	143	191	197	165	440	1344
8851	0	9	45	91	102	177	182	181	556	1343
8852	0	0	12	77	150	182	181	152	589	1343
8901	0	0	5	8	31	83	159	249	809	1344
8902	0	3	13	57	78	147	227	189	629	1343
8903	0	2	6	47	114	177	217	151	630	1344
8904	39	227	272	196	176	114	99	64	157	1344
8905	1	92	126	191	253	218	172	106	185	1344
8906	18	122	134	146	138	135	109	66	476	1344
8907	0	2	20	109	143	257	286	232	295	1344
8908	1	28	46	115	151	154	184	186	479	1344
8909	2	59	135	223	158	91	70	102	504	1344
8910	1	2	3	21	38	85	132	163	899	1344
8911	5	63	212	164	139	120	143	101	397	1344
8912	0	1	14	54	100	141	124	140	311	885
Total	422	2728	3991	4990	5148	5264	4786	3913	10725	41967

**Table 7: Mean Differences of Two Identical Plastic
Gill Multi-Plate Shields by Wind Speed
(YSI-10-YSI-20) Daytime Data (Greater than 5 Wm⁻²)**

Date (YYWK)	0-1 m s ⁻¹	1-2 m s ⁻¹	2-3 m s ⁻¹	3-4 m s ⁻¹	4-5 m s ⁻¹	5-6 m s ⁻¹	6-7 m s ⁻¹	7-8 m s ⁻¹	>8 m s ⁻¹
8825	-0.002	-0.013	-0.028	-0.013	0.011	0.037	0.017	0.010	0.013
8826	-0.241	-0.125	-0.045	0.033	-0.015	-0.021	-0.019	-0.005	-0.011
8827	-0.309	-0.219	-0.236	-0.064	0.005	-0.015	-0.062	-0.013	0.025
8828	0.134	-0.023	0.018	0.027	-0.029	-0.008	-0.021	0.001	-0.000
8829	-0.159	-0.146	-0.044	-0.004	-0.004	0.006	-0.012	0.025	0.016
8830	-0.097	-0.038	-0.018	0.001	0.006	0.006	-0.001	-0.008	0.002
8831	-0.046	-0.057	-0.039	-0.077	-0.076	-0.042	-0.012	0.007	0.012
8832	-0.138	-0.101	-0.052	-0.010	0.004	0.001	0.002	0.008	0.013
8833	-0.105	-0.057	-0.052	-0.062	-0.027	-0.026	-0.036	-0.022	-0.000
8834	-0.065	-0.101	-0.109	-0.040	-0.028	-0.005	0.010	0.001	0.019
8835	0.002	-0.073	-0.083	-0.043	-0.040	-0.015	-0.003	-0.013	0.004
8836	0.040	-0.148	-0.050	-0.017	-0.031	-0.050	-0.065	-0.004	-0.001
8837	0.051	-0.095	-0.079	-0.129	-0.079	-0.038	-0.003	-0.004	-0.008
8838	-0.002	-0.126	-0.063	-0.071	-0.023	-0.005	0.004	-0.015	0.001
8844	0.126	0.195	-0.030	-0.065	-0.049	-0.028	-0.001	0.008	0.037
8845	0.112	0.035	0.033	-0.004	-0.017	-0.024	-0.002	-0.037	-0.023
8846	0.025	0.022	0.046	0.027	-0.037	0.001	0.011	-0.018	-0.036
8847	-0.131	-0.113	0.007	-0.031	-0.013	-0.008	0.018	0.052	-0.013
8848	-0.060	-0.151	-0.095	0.009	0.004	-0.002	-0.022	-0.029	-0.030
8849	-	0.123	0.035	0.001	-0.022	-0.032	0.009	-0.005	-0.044
8850	-	-	-0.000	-0.006	0.015	-0.000	-0.010	-0.016	-0.015
8851	-	-0.009	0.046	0.003	-0.036	-0.018	-0.013	0.003	-0.013
8852	-	-	0.077	-0.009	-0.004	-0.028	-0.019	-0.040	-0.023
8901	-	-	-0.024	-0.017	-0.042	-0.029	-0.024	-0.027	-0.045
8902	-	0.001	0.036	0.019	0.008	-0.000	-0.013	-0.011	-0.032
8903	-	-	-0.015	0.006	0.013	-0.000	-0.033	-0.038	0.022
8904	-0.047	-0.068	-0.016	-0.023	-0.018	-0.011	-0.020	-0.025	-0.024
8905	-	0.001	-0.001	0.008	-0.008	-0.009	-0.015	-0.023	-0.044
8906	0.004	0.010	-0.008	0.020	0.023	0.023	0.015	0.034	-0.003
8907	-	-	0.011	0.010	-0.021	0.015	0.024	0.007	-0.038
8908	0.022	-0.000	-0.000	0.021	0.016	0.017	0.026	0.028	0.016
8909	0.050	-0.066	-0.024	-0.023	-0.035	0.044	0.009	0.001	-0.007
8910	0.019	0.020	0.272	0.114	0.116	0.076	0.048	0.051	0.016
8911	-	0.065	-0.032	-0.008	0.033	0.032	0.001	-0.010	0.000
8912	-	0.210	0.105	0.042	0.055	0.056	0.033	-0.001	0.011
Total	-0.056	-0.067	-0.036	-0.020	-0.017	-0.006	-0.007	-0.006	-0.008

Table 8: Wind Speed Distribution
Daytime Data (Greater than 5 Wm⁻²)

Date (YYWK)	0-1 m s ⁻¹	1-2 m s ⁻¹	2-3 m s ⁻¹	3-4 m s ⁻¹	4-5 m s ⁻¹	5-6 m s ⁻¹	6-7 m s ⁻¹	7-8 m s ⁻¹	>8 m s ⁻¹	Total
8825	10	25	17	50	41	26	14	10	5	198
8826	5	53	77	63	44	40	50	33	15	380
8827	4	18	25	34	43	55	57	44	33	313
8828	8	47	99	98	108	117	91	92	54	714
8829	2	82	170	153	117	105	70	48	46	793
8830	21	92	133	111	114	125	111	64	21	792
8831	30	93	111	71	71	107	67	82	158	790
8832	2	46	40	57	96	146	136	100	151	774
8833	20	89	83	104	74	76	78	35	196	755
8834	32	97	148	188	78	68	43	39	43	736
8835	1	76	131	141	132	74	76	49	38	718
8836	2	46	91	130	93	78	57	56	145	698
8837	5	25	68	154	160	106	48	25	98	689
8838	7	50	24	28	6	12	11	33	39	210
8844	2	10	17	31	47	26	12	12	46	203
8845	3	35	59	39	65	73	75	63	144	556
8846	1	33	38	70	75	71	69	53	128	538
8847	16	23	75	108	103	52	26	30	91	524
8848	1	14	24	8	23	48	69	99	219	505
8849	0	7	47	72	49	72	54	48	167	516
8850	0	0	10	29	61	89	112	83	125	509
8851	0	1	20	35	37	56	68	56	227	500
8852	0	0	9	41	67	75	60	50	203	505
8901	0	0	4	6	26	43	66	89	277	511
8902	0	1	3	22	27	46	95	70	248	512
8903	0	0	3	27	58	73	75	73	223	532
8904	10	80	71	53	71	62	42	35	116	540
8905	0	6	26	61	99	137	114	55	50	548
8906	14	36	43	71	60	45	38	20	242	569
8907	0	0	13	59	84	131	109	72	114	582
8908	1	25	29	58	44	50	62	70	246	585
8909	1	17	54	101	56	14	41	57	283	624
8910	1	2	3	19	23	37	52	60	438	635
8911	0	25	96	80	66	50	58	54	223	652
8912	0	1	8	31	38	56	62	83	164	443
Total	199	1155	1869	2403	2356	2441	2268	1942	5016	19649

**Table 9: Comparison of Aluminum and Plastic Multi-Plate Shields
(VAWR-705-VAWR-121) All Data**

Date (YYWK)	Recs	Average			Standard Deviation		
		Alum (C)	Plas (C)	Al-Pl (C)	Alum (C)	Plas (C)	Al-Pl (C)
8807	828	2.660	2.654	0.007	2.463	2.397	0.197
8808	1345	0.473	0.510	-0.037	3.598	3.588	0.107
8809	1345	0.992	0.992	-0.001	2.843	2.866	0.183
8810	1345	3.456	3.490	-0.034	2.324	2.311	0.081
8811	1345	3.059	3.067	-0.008	1.843	1.852	0.087
8812	1345	2.317	2.346	-0.029	5.345	5.335	0.081
8813	1345	6.462	6.471	-0.009	2.408	2.378	0.110
8814	1345	6.717	6.710	0.007	2.554	2.506	0.100
8815	1345	4.994	5.007	-0.013	2.607	2.591	0.053
8816	1345	6.714	6.734	-0.020	1.866	1.868	0.058
8817	1345	8.657	8.653	0.004	1.495	1.490	0.095
8818	1345	9.405	9.407	-0.002	2.763	2.760	0.070
8819	1345	10.627	10.609	0.018	2.581	2.529	0.124
8820	1345	12.444	12.430	0.014	2.194	2.094	0.178
8821	1345	13.209	13.264	-0.055	1.801	1.819	0.104
8822	1345	14.165	14.197	-0.032	3.521	3.526	0.163
8823	1345	15.189	15.289	-0.100	2.942	2.977	0.137
8824	1345	18.401	18.432	-0.031	1.983	1.991	0.161
8825	1345	17.231	17.236	-0.004	2.213	2.189	0.129
8826	1345	16.687	16.691	-0.004	1.854	1.830	0.189
8827	1345	19.179	19.280	-0.101	1.772	1.837	0.150
8828	1345	21.114	21.135	-0.021	1.680	1.644	0.143
8829	1345	21.469	21.482	-0.013	1.687	1.670	0.105
Total	30418	10.373	10.394	-0.021	2.587	2.576	0.127

**Table 10: Comparison of Aluminum and Plastic Multi-Plate Shields
(VAWR-705–VAWR-121) Nighttime Data (less than 5 Wm⁻²)**

Date (YYWK)	Recs	Average			Standard Deviation		
		Alum (C)	Plas (C)	Al-Pl (C)	Alum (C)	Plas (C)	Al-Pl (C)
8807	445	2.148	2.151	-0.003	2.434	2.374	0.218
8808	739	0.019	0.057	-0.039	4.031	4.006	0.092
8809	722	0.497	0.486	0.011	2.845	2.877	0.223
8810	694	2.822	2.843	-0.021	2.265	2.241	0.050
8811	698	2.739	2.751	-0.012	1.638	1.639	0.043
8812	668	1.866	1.887	-0.021	5.215	5.226	0.044
8813	648	5.717	5.747	-0.030	2.368	2.328	0.075
8814	640	6.014	6.028	-0.013	1.913	1.910	0.047
8815	613	4.763	4.780	-0.016	2.737	2.722	0.039
8816	600	6.204	6.218	-0.014	1.453	1.459	0.034
8817	583	7.738	7.754	-0.015	1.205	1.207	0.054
8818	577	8.581	8.602	-0.021	2.208	2.203	0.034
8819	547	9.306	9.344	-0.038	2.475	2.456	0.071
8820	557	11.203	11.249	-0.046	1.593	1.536	0.094
8821	531	12.579	12.578	0.000	1.366	1.369	0.032
8822	522	13.260	13.333	-0.073	2.647	2.674	0.136
8823	502	13.871	13.890	-0.018	2.614	2.596	0.075
8824	504	16.999	17.001	-0.002	1.408	1.404	0.031
8825	504	16.526	16.549	-0.023	1.817	1.807	0.041
8826	512	15.846	15.836	0.009	1.546	1.521	0.123
8827	507	18.079	18.082	-0.003	1.266	1.264	0.053
8828	521	19.852	19.855	-0.003	0.726	0.716	0.030
8829	557	20.852	20.866	-0.014	1.370	1.341	0.052
Total	13391	8.822	8.840	-0.018	2.418	2.410	0.090

**Table 11: Comparison of Aluminum and Plastic Multi-Plate Shields
(VAWR-705--VAWR-121) Daytime Data (Greater than 5 Wm⁻²)**

Date (YYWK)	Recs	Average			Standard Deviation		
		Alum (C)	Plas (C)	Al-Pl (C)	Alum (C)	Plas (C)	Al-Pl (C)
8807	383	3.255	3.237	0.018	2.364	2.291	0.169
8808	606	1.027	1.062	-0.035	2.894	2.910	0.123
8809	623	1.565	1.579	-0.014	2.733	2.741	0.117
8810	651	4.132	4.180	-0.048	2.192	2.182	0.102
8811	647	3.403	3.407	-0.004	1.985	2.004	0.118
8812	677	2.762	2.798	-0.037	5.438	5.407	0.105
8813	697	7.154	7.144	0.010	2.235	2.222	0.132
8814	705	7.356	7.330	0.026	2.877	2.806	0.129
8815	732	5.188	5.197	-0.010	2.479	2.461	0.062
8816	745	7.124	7.150	-0.026	2.053	2.050	0.072
8817	762	9.360	9.341	0.019	1.302	1.309	0.114
8818	768	10.024	10.012	0.013	2.971	2.974	0.085
8819	798	11.532	11.476	0.056	2.240	2.192	0.137
8820	788	13.320	13.264	0.056	2.138	2.034	0.208
8821	814	13.620	13.710	-0.090	1.929	1.935	0.119
8822	823	14.739	14.745	-0.006	3.871	3.876	0.174
8823	843	15.974	16.122	-0.148	2.845	2.876	0.143
8824	841	19.242	19.289	-0.048	1.793	1.789	0.201
8825	841	17.654	17.647	0.007	2.320	2.293	0.158
8826	833	17.204	17.217	-0.012	1.839	1.806	0.220
8827	838	19.844	20.004	-0.160	1.702	1.749	0.158
8828	824	21.912	21.945	-0.033	1.622	1.548	0.180
8829	788	21.905	21.917	-0.012	1.753	1.742	0.130
Total	17027	11.593	11.616	-0.023	2.534	2.519	0.145

Table 12: Mean Differences of Aluminum minus Plastic
 Gill Multi-Plate Shields by Wind Speed
 (VAWR-705-VAWR-121) All Data

Date (YYWK)	0-1 m s ⁻¹	1-2 m s ⁻¹	2-3 m s ⁻¹	3-4 m s ⁻¹	4-5 m s ⁻¹	5-6 m s ⁻¹	6-7 m s ⁻¹	7-8 m s ⁻¹	>8 m s ⁻¹
8807	-0.223	-0.082	-0.006	0.084	0.072	0.090	-0.035	-0.013	0.093
8808	-0.155	-0.057	0.020	-0.015	-0.028	-0.025	-0.015	-0.018	-0.058
8809	-0.170	-0.048	-0.048	-0.014	0.083	0.046	-0.006	-0.010	-0.015
8810	-0.158	-0.015	-0.023	-0.022	-0.027	-0.011	-0.038	-0.064	-0.049
8811	-0.022	-0.026	-0.009	-0.007	-0.000	-0.007	-0.001	0.019	-0.008
8812	0.022	-0.054	0.000	-0.034	-0.050	-0.045	-0.044	-0.039	-0.011
8813	-0.043	0.011	-0.013	0.002	-0.002	-0.047	-0.041	-0.019	0.049
8814	0.056	0.040	0.050	0.021	-0.005	-0.010	-0.003	-0.007	-0.007
8815	-	-0.033	-0.036	-0.005	-0.000	-0.009	-0.015	-0.019	-0.023
8816	-0.017	-0.013	0.005	-0.011	-0.023	-0.019	-0.020	-0.022	-0.030
8817	-0.080	0.021	-0.005	0.000	0.019	0.020	0.001	-0.006	-0.001
8818	0.011	0.040	0.001	0.002	-0.011	-0.011	-0.012	0.002	-0.018
8819	-0.126	-0.053	0.051	0.040	0.040	0.025	0.008	-0.038	-0.018
8820	-0.109	-0.006	0.084	0.068	0.022	0.004	-0.050	-0.142	-0.111
8821	-0.048	-0.030	-0.040	-0.027	-0.043	-0.038	-0.048	-0.080	-0.119
8822	-0.234	-0.078	-0.032	0.023	0.029	0.000	-0.013	0.013	0.000
8823	-0.166	-0.127	-0.088	-0.088	-0.087	-0.116	-0.081	-0.113	-0.086
8824	-0.050	-0.045	0.023	-0.002	-0.061	-0.063	-0.041	-0.039	-0.134
8825	0.021	-0.007	0.046	0.039	0.022	-0.026	-0.068	-0.054	-0.039
8826	-0.147	-0.068	0.022	0.010	0.008	-0.038	0.008	-0.005	0.060
8827	-0.097	-0.069	-0.059	-0.046	-0.082	-0.086	-0.178	-0.216	-0.235
8828	-0.039	-0.030	0.013	0.027	-0.008	-0.000	-0.031	-0.124	-0.171
8829	-0.034	-0.067	-0.024	0.013	0.012	-0.016	-0.037	-0.013	0.020
Total	-0.101	-0.037	-0.004	0.004	-0.002	-0.017	-0.034	-0.042	-0.034

Table 13: Wind Speed Distribution

All Data

Date (YYWK)	0-1 m s ⁻¹	1-2 m s ⁻¹	2-3 m s ⁻¹	3-4 m s ⁻¹	4-5 m s ⁻¹	5-6 m s ⁻¹	6-7 m s ⁻¹	7-8 m s ⁻¹	>8 m s ⁻¹	Total
8807	80	117	149	125	93	83	36	30	115	828
8808	50	191	162	165	103	116	77	78	403	1345
8809	74	68	171	184	232	222	184	101	109	1345
8810	26	50	155	211	215	191	151	176	170	1345
8811	51	169	257	235	236	166	55	49	127	1345
8812	48	84	134	102	102	178	196	167	334	1345
8813	161	227	213	211	112	132	101	56	132	1345
8814	54	104	119	130	124	163	186	161	304	1345
8815	0	20	132	261	265	206	180	146	135	1345
8816	11	46	108	141	153	166	176	137	407	1345
8817	27	136	201	235	196	154	126	123	147	1345
8818	31	141	147	211	237	205	125	100	148	1345
8819	45	171	166	278	344	220	81	23	17	1345
8820	163	280	237	261	211	132	37	17	7	1345
8821	48	127	173	160	192	171	156	103	215	1345
8822	134	191	273	315	194	114	68	42	14	1345
8823	57	191	216	223	202	113	100	60	183	1345
8824	76	267	307	205	139	135	93	53	70	1345
8825	22	131	177	221	219	163	176	109	127	1345
8826	22	148	207	263	233	167	125	96	84	1345
8827	46	165	231	168	186	241	148	94	66	1345
8828	23	120	199	216	223	228	150	117	69	1345
8829	12	161	269	237	228	160	100	98	80	1345
Total	1261	3305	4403	4758	4439	3826	2827	2136	3463	30418

Table 14: Mean Differences of Aluminum minus Plastic

Gill Multi-Plate Shields by Wind Speed

(VAWR-705-VAWR-121) Daytime Data (Greater than 5 Wm⁻²)

Date (YYWK)	0-1 m s ⁻¹	1-2 m s ⁻¹	2-3 m s ⁻¹	3-4 m s ⁻¹	4-5 m s ⁻¹	5-6 m s ⁻¹	6-7 m s ⁻¹	7-8 m s ⁻¹	>8 m s ⁻¹
8807	-0.053	-0.041	-0.003	0.016	0.125	-0.014	-0.137	-0.045	0.109
8808	-0.022	0.012	0.056	0.004	-0.044	-0.038	-0.063	-0.070	-0.093
8809	0.063	0.082	-0.017	-0.025	-0.020	0.019	-0.016	-0.030	-0.084
8810	-0.152	0.117	0.006	-0.016	-0.049	-0.029	-0.085	-0.091	-0.090
8811	0.021	-0.017	-0.008	-0.009	0.008	-0.015	0.014	0.031	-0.010
8812	0.180	-0.034	0.023	-0.019	-0.100	-0.079	-0.069	-0.066	-0.021
8813	0.053	0.087	0.027	0.017	0.004	-0.087	-0.057	-0.021	0.012
8814	0.224	0.161	0.125	0.055	-0.002	-0.010	-0.005	-0.008	-0.008
8815	-	-	0.038	0.013	0.012	-0.012	-0.018	-0.026	-0.033
8816	0.250	0.022	0.052	0.022	-0.026	-0.033	-0.033	-0.036	-0.055
8817	-0.080	0.072	0.034	0.015	0.047	0.027	0.005	-0.010	-0.004
8818	0.050	0.102	0.058	0.028	-0.003	-0.006	-0.013	0.005	-0.020
8819	-0.152	-0.029	0.147	0.088	0.062	0.034	0.014	-0.047	-0.029
8820	-0.088	0.034	0.138	0.103	0.046	0.021	-0.065	-0.176	-0.111
8821	-0.080	-0.044	-0.065	-0.058	-0.080	-0.081	-0.089	-0.110	-0.129
8822	-0.195	-0.041	-0.033	0.041	0.062	0.002	-0.006	0.017	0.003
8823	-0.273	-0.210	-0.118	-0.127	-0.144	-0.148	-0.122	-0.164	-0.159
8824	-0.080	-0.056	0.040	-0.002	-0.099	-0.095	-0.073	-0.071	-0.181
8825	0.053	0.024	0.117	0.085	0.049	-0.022	-0.082	-0.079	-0.071
8826	-0.171	-0.117	0.008	0.009	0.012	-0.047	0.018	-0.003	0.067
8827	-0.135	-0.126	-0.113	-0.097	-0.154	-0.153	-0.203	-0.216	-0.235
8828	-0.072	-0.033	0.039	0.051	-0.020	-0.008	-0.053	-0.138	-0.171
8829	0.018	-0.102	-0.022	0.031	0.023	-0.028	-0.067	-0.025	0.031
Total	-0.037	-0.018	0.014	0.016	-0.006	-0.035	-0.054	-0.062	-0.061

Table 15: Wind Speed Distribution
Daytime Data (Greater than 5 Wm⁻²)

Date (YYWK)	0-1 m s ⁻¹	1-2 m s ⁻¹	2-3 m s ⁻¹	3-4 m s ⁻¹	4-5 m s ⁻¹	5-6 m s ⁻¹	6-7 m s ⁻¹	7-8 m s ⁻¹	>8 m s ⁻¹	Total
8807	17	42	81	70	41	25	22	17	68	383
8808	12	80	102	69	35	24	22	23	239	606
8809	13	21	53	90	138	105	101	54	48	623
8810	7	20	77	115	87	63	64	125	93	651
8811	30	83	147	114	96	51	23	31	72	647
8812	16	37	77	29	25	87	117	93	196	677
8813	60	112	97	124	61	74	74	50	45	697
8814	31	36	51	51	45	72	111	117	191	705
8815	0	0	8	103	132	131	143	110	105	732
8816	1	23	59	66	98	87	95	79	237	745
8817	27	87	74	78	96	111	106	87	96	762
8818	21	78	49	79	149	98	100	70	124	768
8819	5	59	83	164	250	159	52	19	7	798
8820	39	131	151	187	141	90	28	14	7	788
8821	10	50	97	74	107	97	101	78	200	814
8822	47	116	200	208	110	60	38	32	12	823
8823	25	83	147	152	125	90	71	42	108	843
8824	42	178	185	112	87	94	60	29	54	841
8825	14	57	91	128	146	121	137	78	69	841
8826	17	91	129	142	123	112	95	73	51	833
8827	9	77	122	92	103	144	131	94	66	838
8828	10	52	111	121	125	133	96	107	69	824
8829	4	63	169	152	136	104	62	59	39	788
Total	457	1576	2360	2520	2456	2132	1849	1481	2196	17027

**Table 16: Comparison of Aluminum and Plastic
Multi-Plate (with solar fan) Shields
(VAWR-705-VAWR-121) All Data**

Date (YYWK)	Recs	Average			Standard Deviation		
		Alum (C)	Plas (C)	Al-Pl (C)	Alum (C)	Plas (C)	Al-Pl (C)
8830	1034	22.015	22.105	-0.089	1.182	1.248	0.208
8831	1345	23.291	23.375	-0.084	1.279	1.344	0.175
8832	1345	23.744	23.846	-0.103	0.993	1.074	0.142
8833	1345	21.545	21.597	-0.052	1.995	2.015	0.154
8834	1345	18.720	18.764	-0.043	2.404	2.384	0.203
8835	1345	20.358	20.408	-0.051	2.157	2.183	0.156
8836	1345	18.549	18.612	-0.064	2.209	2.196	0.158
8837	1345	16.769	16.837	-0.068	2.287	2.310	0.152
8838	1142	18.535	18.607	-0.072	1.426	1.484	0.175
8839	1345	15.640	15.693	-0.053	2.320	2.346	0.162
8840	1345	12.134	12.192	-0.059	4.059	4.057	0.107
8841	1345	10.486	10.552	-0.066	3.521	3.532	0.109
8842	1345	11.695	11.719	-0.024	3.358	3.327	0.105
8843	876	10.667	10.701	-0.034	2.187	2.198	0.096
Total	17847	17.525	17.586	-0.062	2.433	2.445	0.154

**Table 17: Comparison of Aluminum and Plastic
Multi-Plate (with solar fan) Shields
(VAWR-705–VAWR-121) Nighttime Data (less than 5 Wm⁻²)**

Date (YYWK)	Recs	Average			Standard Deviation		
		Alum (C)	Plas (C)	Al-Pl (C)	Alum (C)	Plas (C)	Al-Pl (C)
8830	392	21.263	21.250	0.013	0.572	0.584	0.029
8831	549	22.549	22.542	0.007	0.898	0.881	0.060
8832	569	23.175	23.163	0.012	0.658	0.658	0.026
8833	583	21.154	21.147	0.008	2.253	2.238	0.055
8834	596	17.812	17.829	-0.017	1.921	1.876	0.085
8835	621	19.695	19.692	0.003	2.106	2.090	0.066
8836	641	18.058	18.047	0.010	1.942	1.939	0.062
8837	649	16.580	16.564	0.017	2.400	2.394	0.030
8838	575	18.149	18.148	0.000	1.242	1.233	0.050
8839	684	14.744	14.790	-0.047	2.149	2.131	0.094
8840	723	11.833	11.875	-0.042	3.999	3.972	0.063
8841	718	10.117	10.102	0.014	3.691	3.697	0.026
8842	749	11.396	11.429	-0.033	3.105	3.099	0.073
8843	519	10.312	10.298	0.014	1.924	1.931	0.028
Total	8568	16.532	16.536	-0.005	2.400	2.390	0.059

**Table 18: Comparison of Aluminum and Plastic
Multi-Plate (with solar fan) Shields
(VAWR-705-VAWR-121) Daytime Data (Greater than 5 Wm⁻²)**

Date (YYWK)	Recs	Average			Standard Deviation		
		Alum (C)	Plas (C)	Al-Pl (C)	Alum (C)	Plas (C)	Al-Pl (C)
8830	642	22.474	22.627	-0.152	1.223	1.259	0.243
8831	796	23.802	23.949	-0.146	1.252	1.307	0.199
8832	776	24.160	24.347	-0.187	0.991	1.043	0.133
8833	762	21.843	21.941	-0.098	1.715	1.752	0.187
8834	749	19.443	19.508	-0.064	2.504	2.482	0.260
8835	724	20.926	21.023	-0.096	2.037	2.073	0.192
8836	704	18.996	19.127	-0.131	2.339	2.290	0.187
8837	696	16.945	17.091	-0.146	2.163	2.200	0.176
8838	567	18.926	19.073	-0.146	1.493	1.570	0.220
8839	661	16.568	16.627	-0.059	2.118	2.188	0.209
8840	622	12.483	12.561	-0.078	4.103	4.126	0.139
8841	627	10.910	11.067	-0.157	3.267	3.260	0.094
8842	596	12.070	12.083	-0.013	3.620	3.561	0.133
8843	357	11.182	11.285	-0.103	2.432	2.422	0.115
Total	9279	18.442	18.556	-0.114	2.350	2.361	0.168

Table 19: Mean Differences of Aluminum minus Plastic
(with solar fan) Gill Multi-Plate Shields by Wind Speed
(VAWR-705-VAWR-121) All Data

Date (YYWK)	0-1 m s ⁻¹	1-2 m s ⁻¹	2-3 m s ⁻¹	3-4 m s ⁻¹	4-5 m s ⁻¹	5-6 m s ⁻¹	6-7 m s ⁻¹	7-8 m s ⁻¹	>8 m s ⁻¹
8830	-0.232	-0.104	-0.071	-0.042	-0.077	-0.071	-0.154	-0.271	-0.120
8831	-0.090	-0.061	-0.011	-0.023	-0.033	-0.069	-0.126	-0.159	-0.234
8832	-0.157	-0.155	-0.044	-0.044	-0.075	-0.114	-0.088	-0.105	-0.212
8833	-0.149	-0.141	-0.024	0.014	-0.043	-0.053	-0.041	-0.053	-0.066
8834	-0.096	-0.092	-0.002	-0.010	-0.060	-0.086	-0.067	-0.070	-0.013
8835	-0.106	-0.101	-0.034	-0.013	-0.056	-0.051	-0.065	-0.096	-0.019
8836	-0.054	-0.078	-0.067	-0.044	-0.050	-0.097	-0.052	-0.037	-0.084
8837	-0.144	-0.307	-0.167	-0.062	-0.058	-0.052	-0.070	-0.030	-0.033
8838	-0.153	-0.189	-0.059	-0.059	-0.100	-0.042	-0.019	-0.039	-0.059
8839	-0.208	-0.091	-0.044	0.006	-0.055	-0.048	-0.023	-0.045	-0.115
8840	-0.289	-0.131	-0.076	-0.055	-0.054	-0.030	-0.062	-0.071	-0.078
8841	-	-0.072	-0.128	-0.075	-0.059	-0.095	-0.088	-0.014	-0.059
8842	-0.108	-0.089	-0.060	-0.021	0.005	-0.006	-0.010	-0.021	-0.005
8843	-	0.047	-0.020	-0.031	-0.024	-0.010	-0.011	-0.038	-0.051
Total	-0.135	-0.111	-0.046	-0.030	-0.050	-0.062	-0.065	-0.071	-0.079

Table 20: Wind Speed Distribution

All Data

Date (YYWK)	0-1 m s ⁻¹	1-2 m s ⁻¹	2-3 m s ⁻¹	3-4 m s ⁻¹	4-5 m s ⁻¹	5-6 m s ⁻¹	6-7 m s ⁻¹	7-8 m s ⁻¹	>8 m s ⁻¹	Total
8830	13	120	232	213	161	143	92	50	10	1034
8831	58	172	181	152	192	191	125	100	174	1345
8832	2	62	91	180	217	253	214	158	168	1345
8833	38	140	172	193	153	140	138	65	306	1345
8834	49	192	333	269	192	134	85	44	47	1345
8835	18	174	274	236	202	127	111	94	109	1345
8836	15	78	214	251	197	143	106	95	246	1345
8837	3	35	80	241	356	299	131	47	153	1345
8838	47	102	138	195	168	131	138	76	147	1142
8839	45	97	283	276	127	96	113	112	196	1345
8840	8	25	118	302	267	237	212	84	92	1345
8841	0	10	18	79	206	216	221	169	426	1345
8842	32	92	181	350	225	136	82	55	192	1345
8843	0	2	45	90	76	117	96	69	381	876
Total	328	1301	2360	3027	2739	2363	1864	1218	2647	17847

**Table 21: Mean Differences of Aluminum minus Plastic
(with solar fan) Gill Multi-Plate Shields by Wind Speed
(VAWR-705-VAWR-121) Daytime Data (Greater than 5 Wm⁻²)**

Date (YYWK)	0-1 m s ⁻¹	1-2 m s ⁻¹	2-3 m s ⁻¹	3-4 m s ⁻¹	4-5 m s ⁻¹	5-6 m s ⁻¹	6-7 m s ⁻¹	7-8 m s ⁻¹	>8 m s ⁻¹
8830	-0.424	-0.224	-0.155	-0.103	-0.125	-0.094	-0.176	-0.271	-0.120
8831	-0.154	-0.094	0.000	-0.079	-0.127	-0.143	-0.227	-0.214	-0.245
8832	-0.157	-0.201	-0.126	-0.162	-0.195	-0.201	-0.157	-0.162	-0.228
8833	-0.145	-0.207	-0.063	0.021	-0.079	-0.100	-0.087	-0.101	-0.128
8834	-0.049	-0.155	0.013	-0.023	-0.111	-0.184	-0.115	-0.082	-0.013
8835	-0.378	-0.180	-0.081	-0.026	-0.082	-0.103	-0.125	-0.179	-0.116
8836	-0.118	-0.158	-0.130	-0.081	-0.106	-0.188	-0.193	-0.098	-0.154
8837	-0.144	-0.317	-0.239	-0.126	-0.131	-0.160	-0.189	-0.076	-0.064
8838	-0.464	-0.353	-0.149	-0.102	-0.181	-0.128	-0.072	-0.072	-0.102
8839	0.007	-0.005	-0.020	0.044	-0.075	-0.110	-0.069	-0.126	-0.171
8840	-0.005	-0.191	-0.109	-0.051	-0.074	-0.039	-0.105	-0.140	-0.109
8841	-	-0.168	-0.194	-0.158	-0.152	-0.176	-0.159	-0.138	-0.147
8842	-0.111	-0.134	-0.045	0.005	0.025	-0.001	-0.019	-0.043	-0.044
8843	-	-	-0.079	-0.076	-0.102	-0.055	-0.057	-0.102	-0.126
Total	-0.166	-0.184	-0.076	-0.052	-0.106	-0.126	-0.133	-0.143	-0.144

Table 22: Wind Speed Distribution
Daytime Data (Greater than 5 Wm⁻²)

Date (YYWK)	0-1 m s ⁻¹	1-2 m s ⁻¹	2-3 m s ⁻¹	3-4 m s ⁻¹	4-5 m s ⁻¹	5-6 m s ⁻¹	6-7 m s ⁻¹	7-8 m s ⁻¹	>8 m s ⁻¹	Total
8830	7	60	120	104	100	109	82	50	10	642
8831	29	91	110	69	76	107	73	75	166	796
8832	2	48	38	58	95	151	125	103	156	776
8833	26	87	89	93	83	81	82	40	181	762
8834	34	89	169	167	103	59	46	35	47	749
8835	4	69	132	141	150	76	62	51	39	724
8836	6	35	98	135	113	81	37	47	152	704
8837	3	34	57	134	174	119	54	22	99	696
8838	12	49	52	114	97	56	60	48	79	567
8839	3	27	121	158	78	40	45	50	139	661
8840	1	8	37	154	132	99	93	35	63	622
8841	0	3	11	41	91	121	128	36	196	627
8842	5	22	46	144	125	96	49	25	84	596
8843	0	0	13	35	28	41	22	33	185	357
Total	132	622	1093	1547	1445	1236	958	650	1596	9279

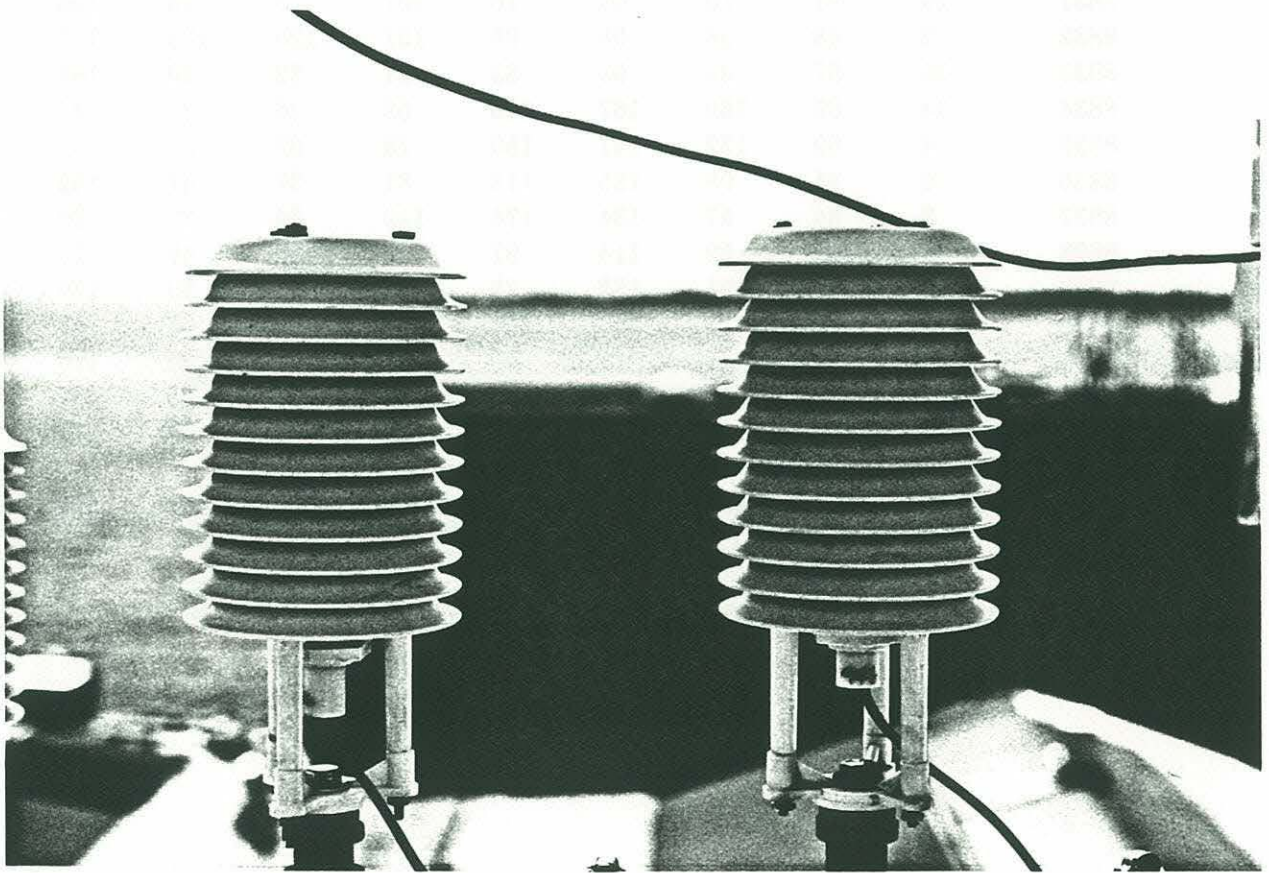

Figure 1: R. M. Young Gill Multi-Plate Radiation Shield (41002).

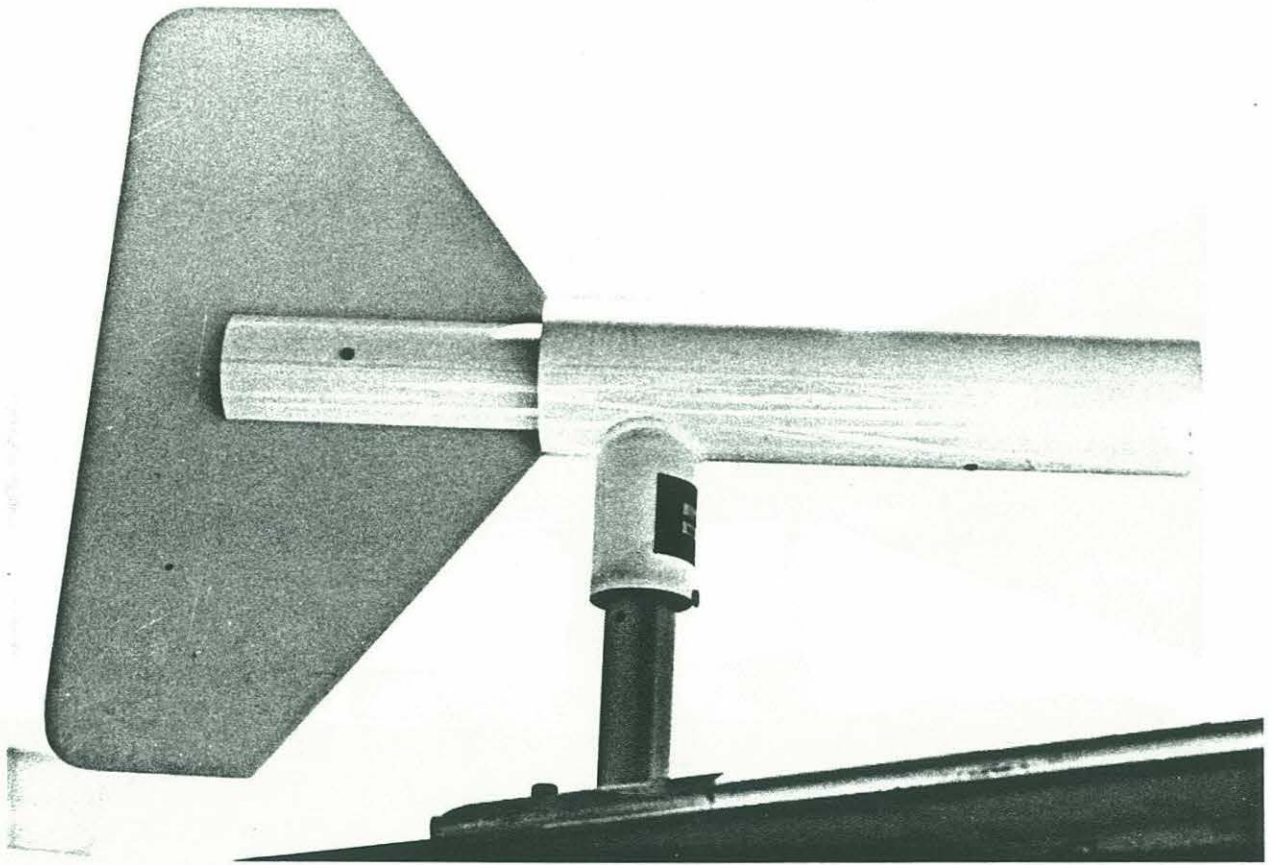

Figure 2: Met One Vane Aspirated Radiation Shield (071A).

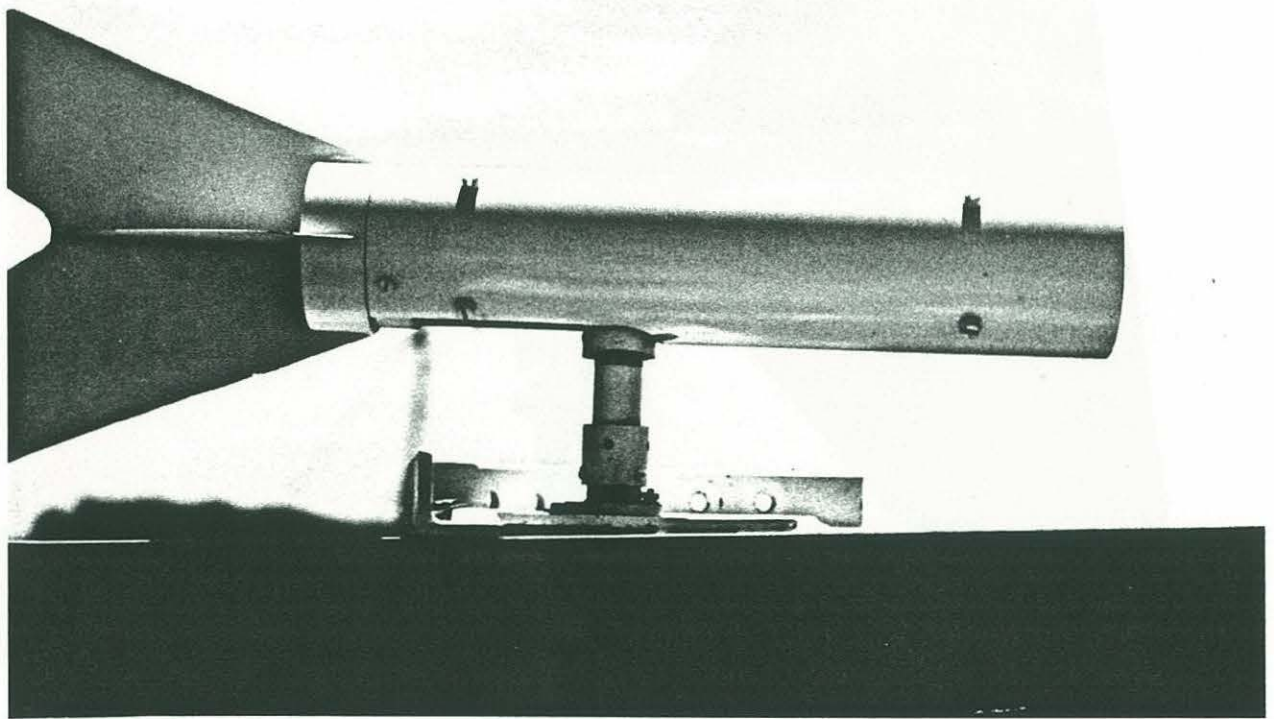

Figure 3: WHOI Vane Aspirated Radiation Shield (Developed by J. Dean).

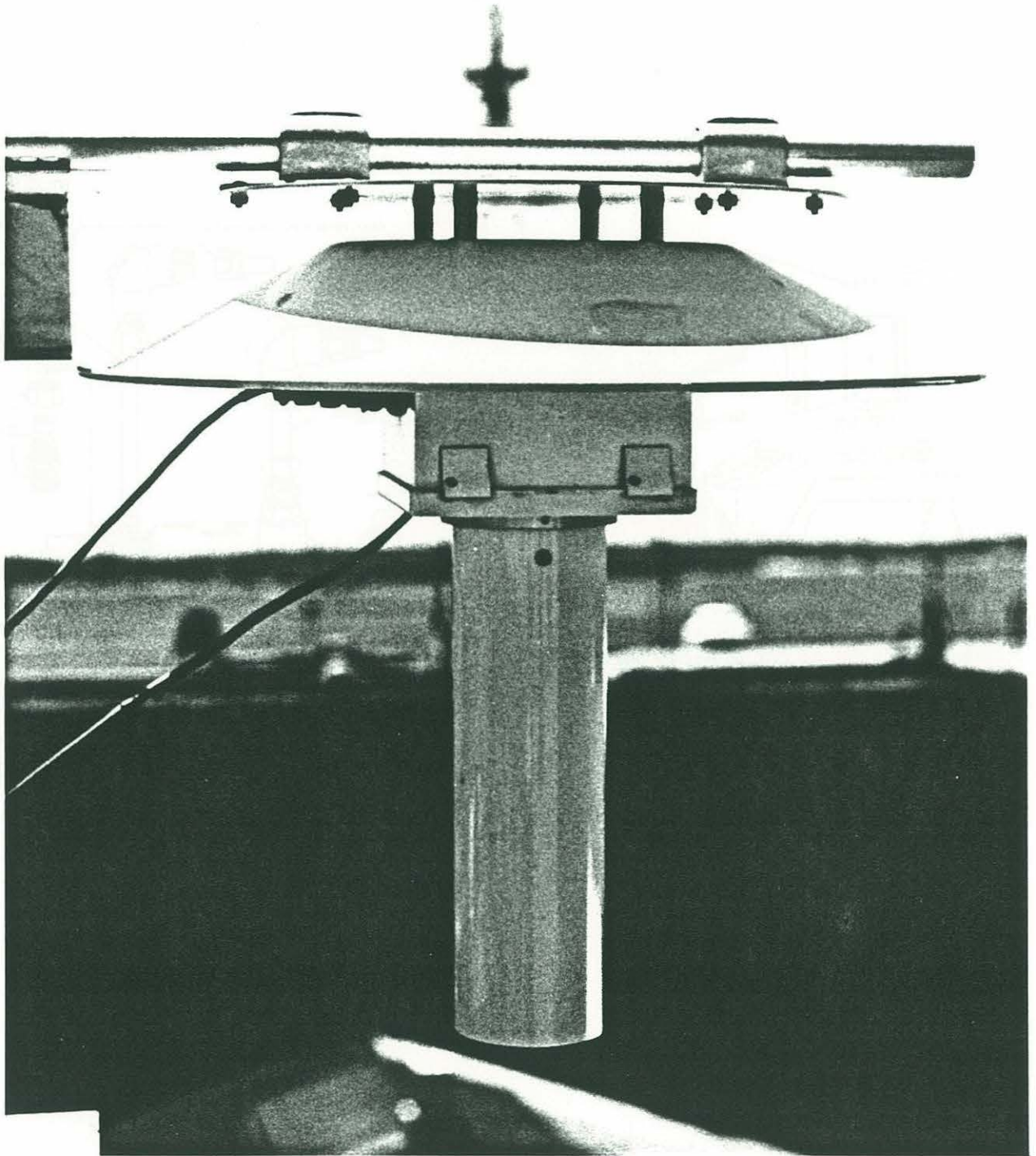

Figure 4: Met One Fan Aspirated Radiation Shield (076).

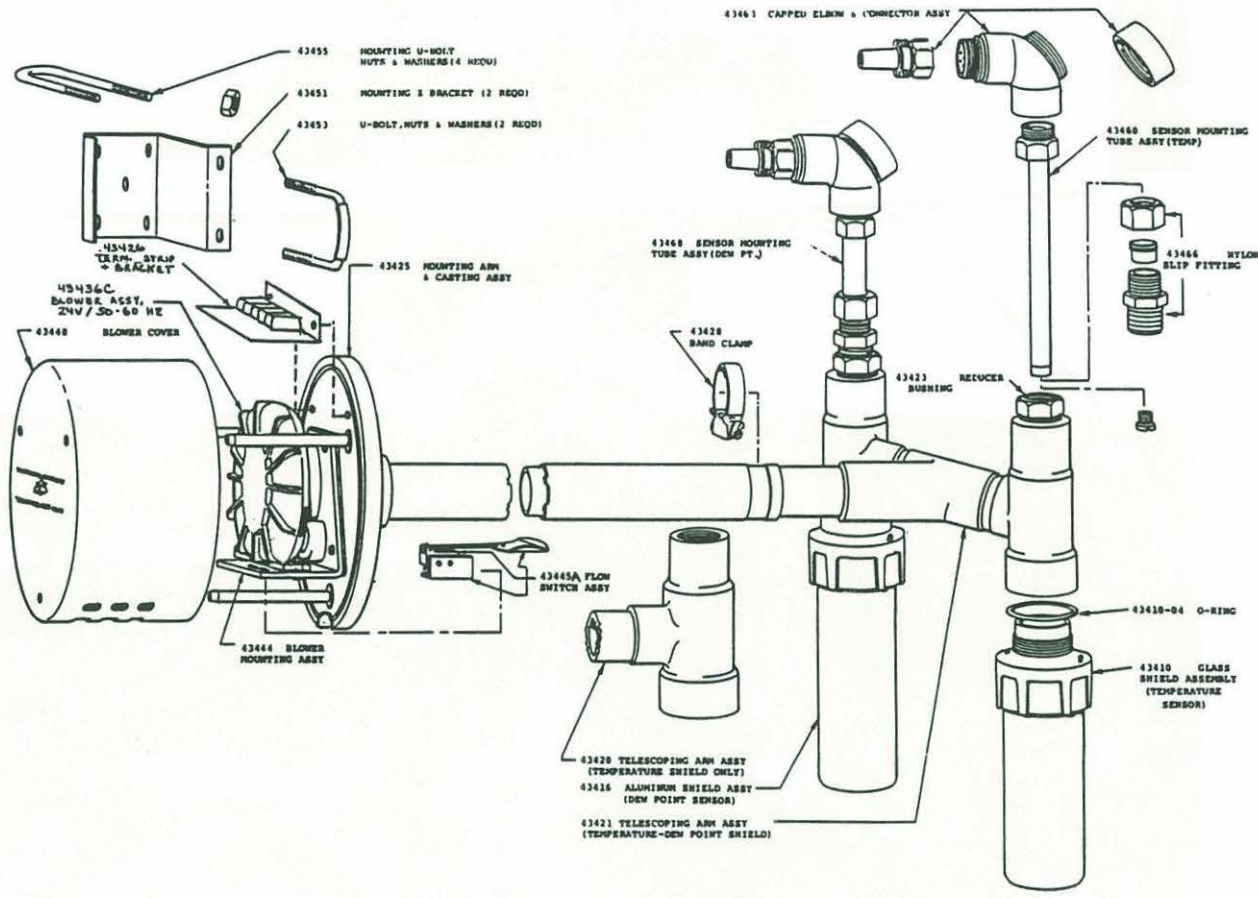

Figure 5: R. M. Young Gill Aspirated Radiation Shield (43404).

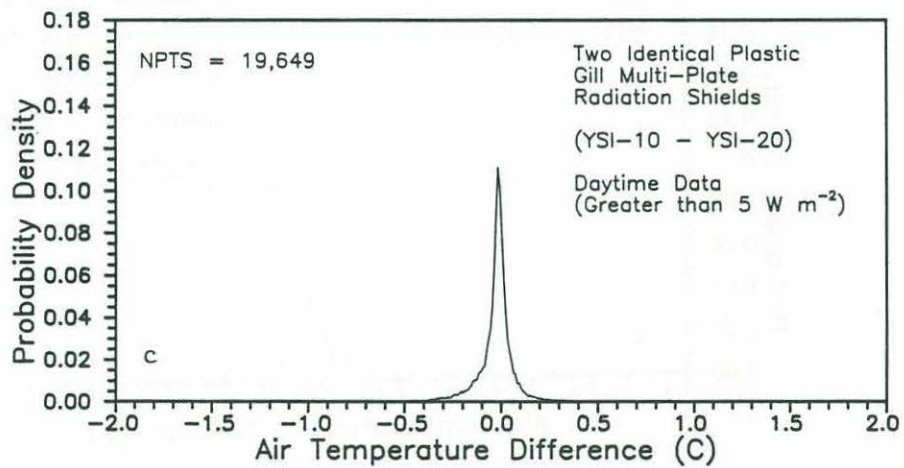
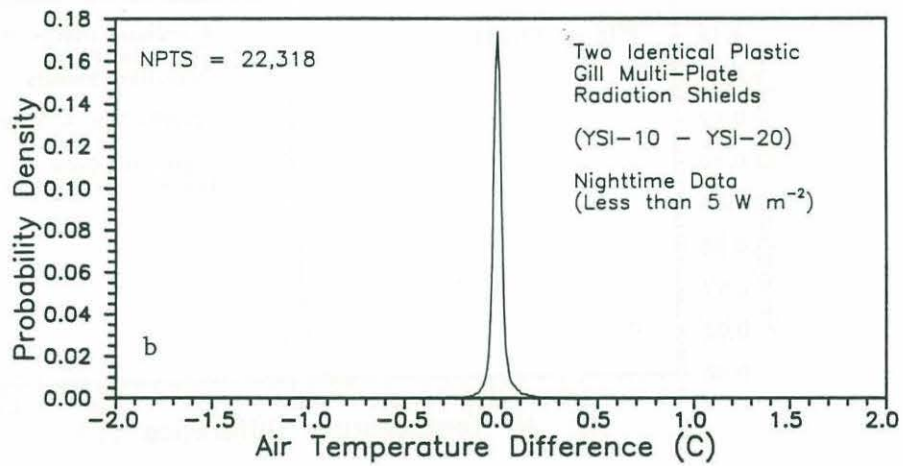
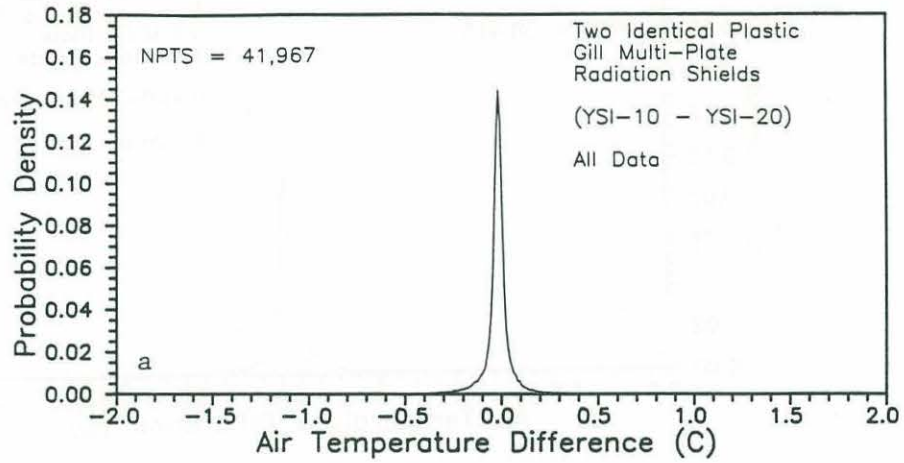

Figure 6: Probability density of air temperature difference between two identical plastic Gill multi-plate radiation shields for (a) all data, (b) nighttime data (insolation less than 5 W m^{-2}), and (c) daytime data (insolation greater than 5 W m^{-2}).

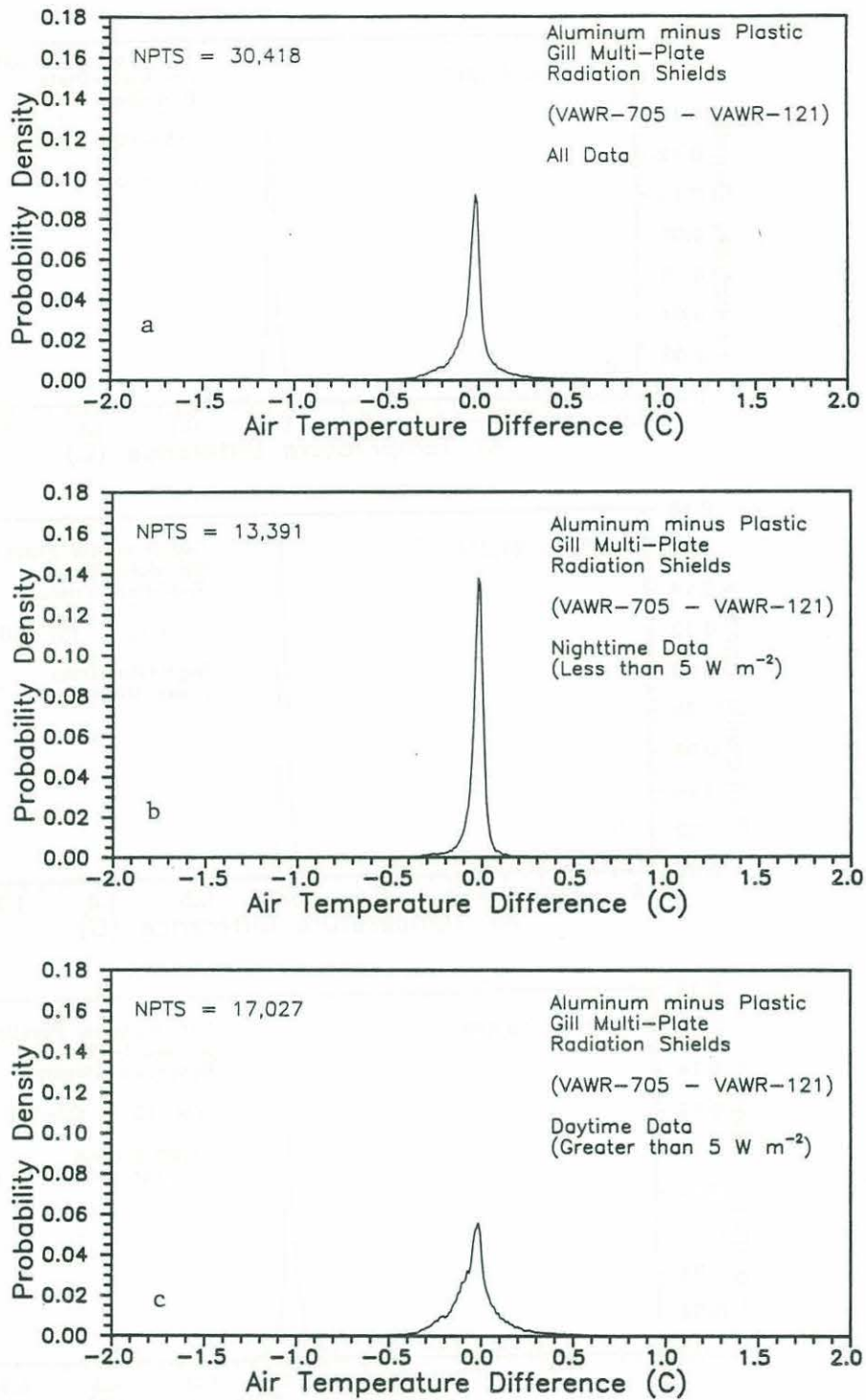

Figure 7: Probability density of air temperature difference between an aluminum and plastic multi-plate radiation shield for (a) all data, (b) nighttime data (insolation less than 5 W m^{-2}), and (c) daytime data (insolation greater than 5 W m^{-2}).

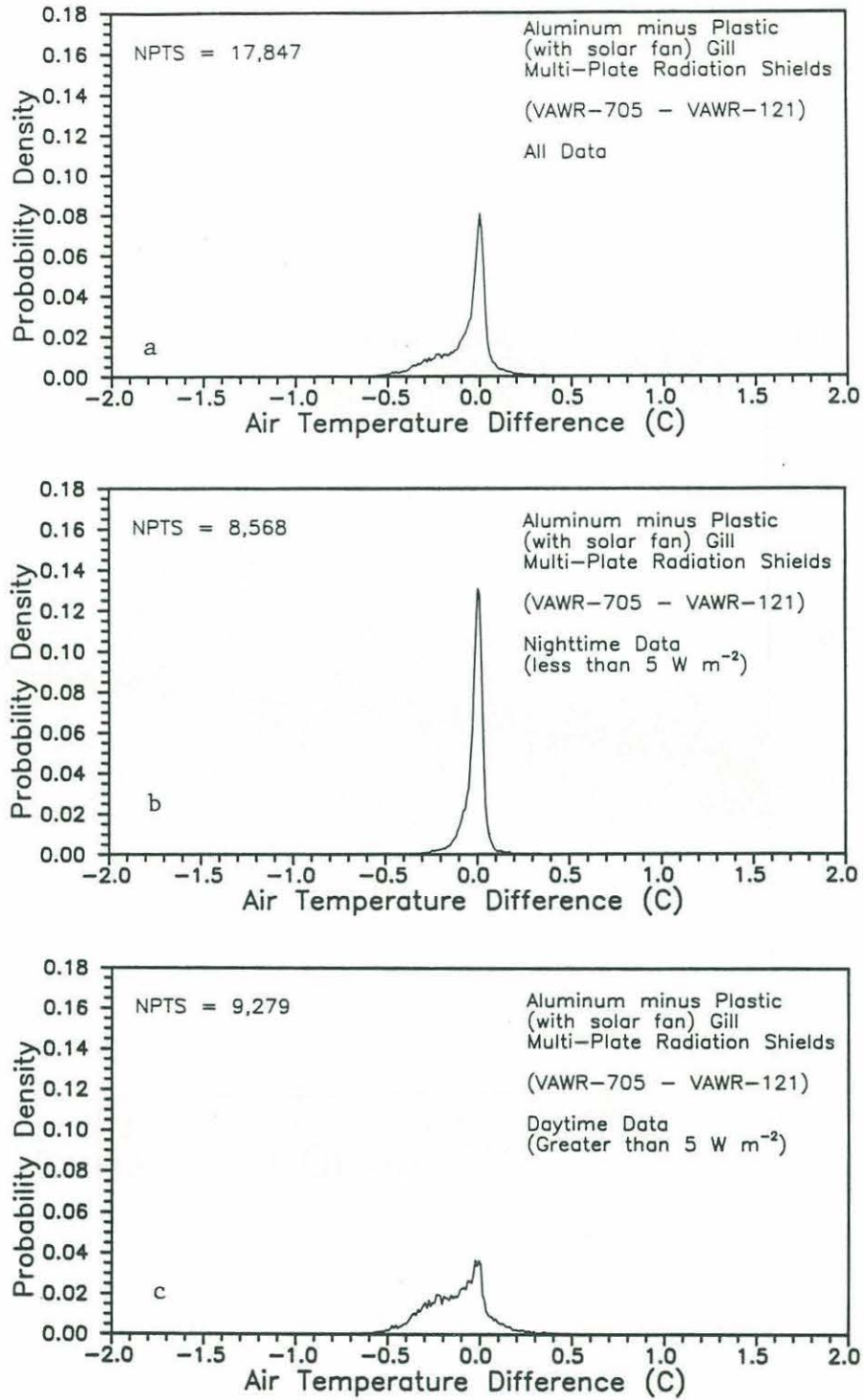

Figure 8: Probability density of air temperature difference between an aluminum and plastic (with solar powered fan) multi-plate radiation shield for (a) all data, (b) nighttime data (insolation less than 5 W m⁻²), and (c) daytime data (insolation greater than 5 W m⁻²).

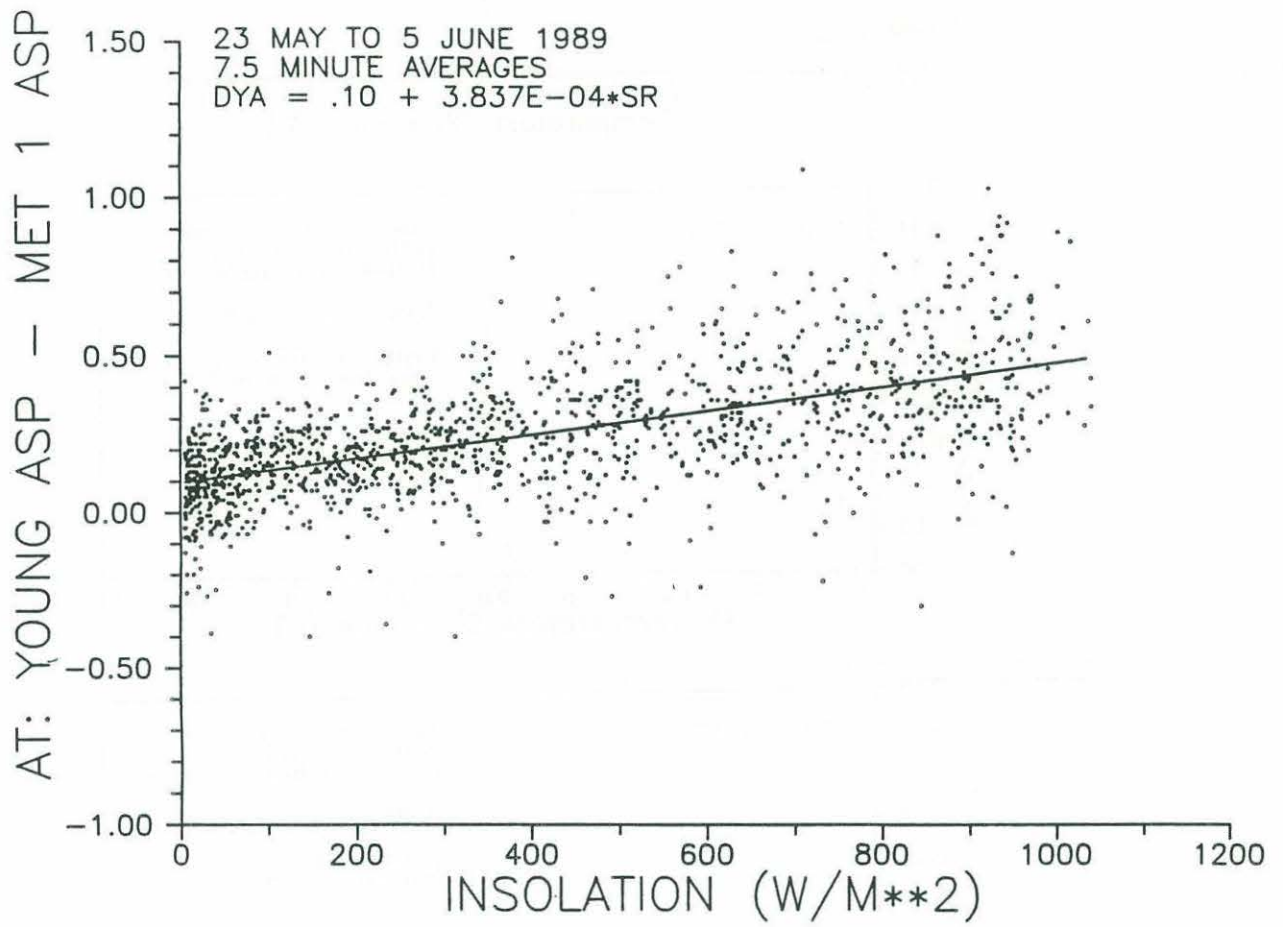

Figure 9: Scatter plot of R. M. Young Gill Aspirated minus Met One Aspirated air temperature as a function of insolation.

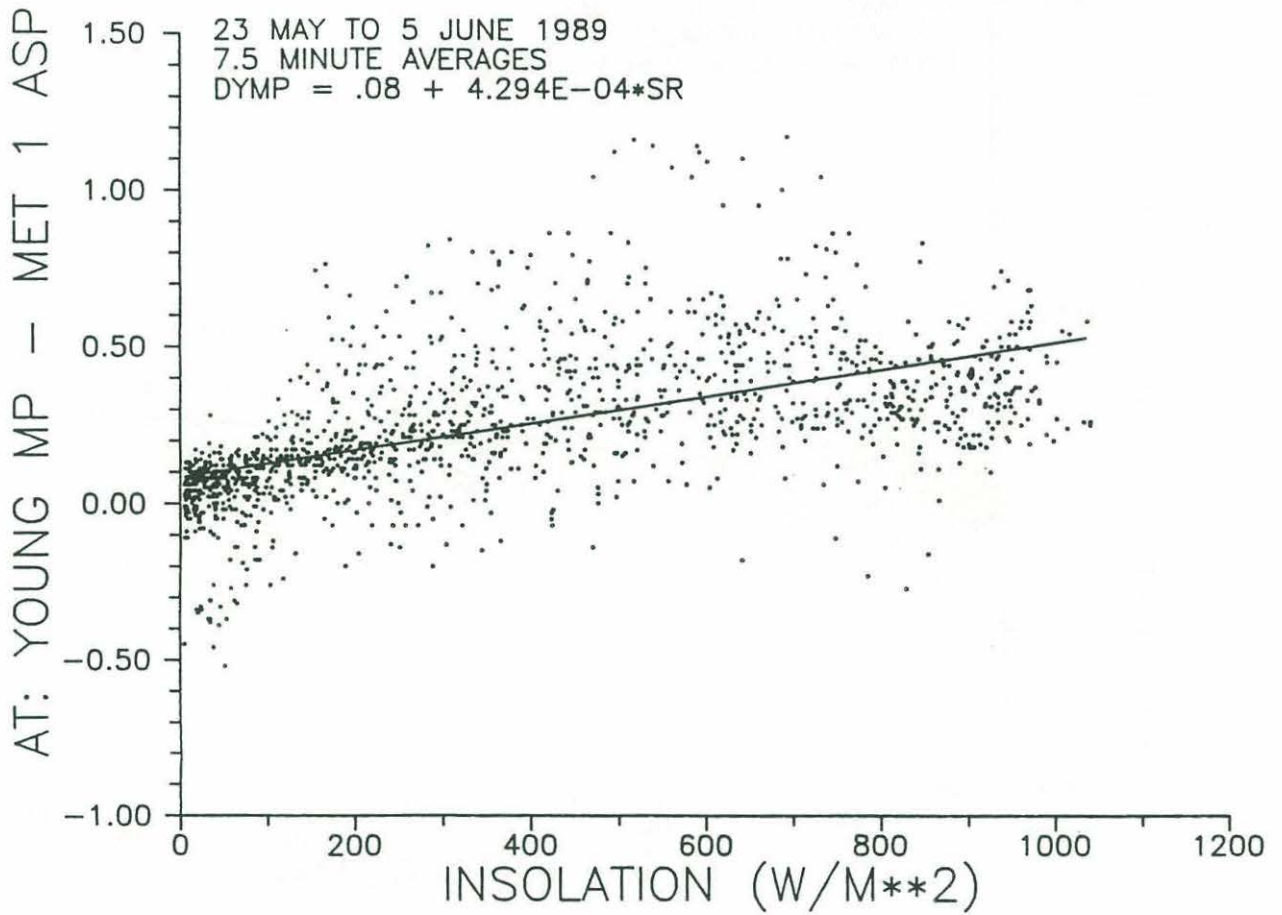

Figure 10: Scatter plot of R. M. Young Gill multi-plate minus Met One Aspirated air temperature as a function of insolation.

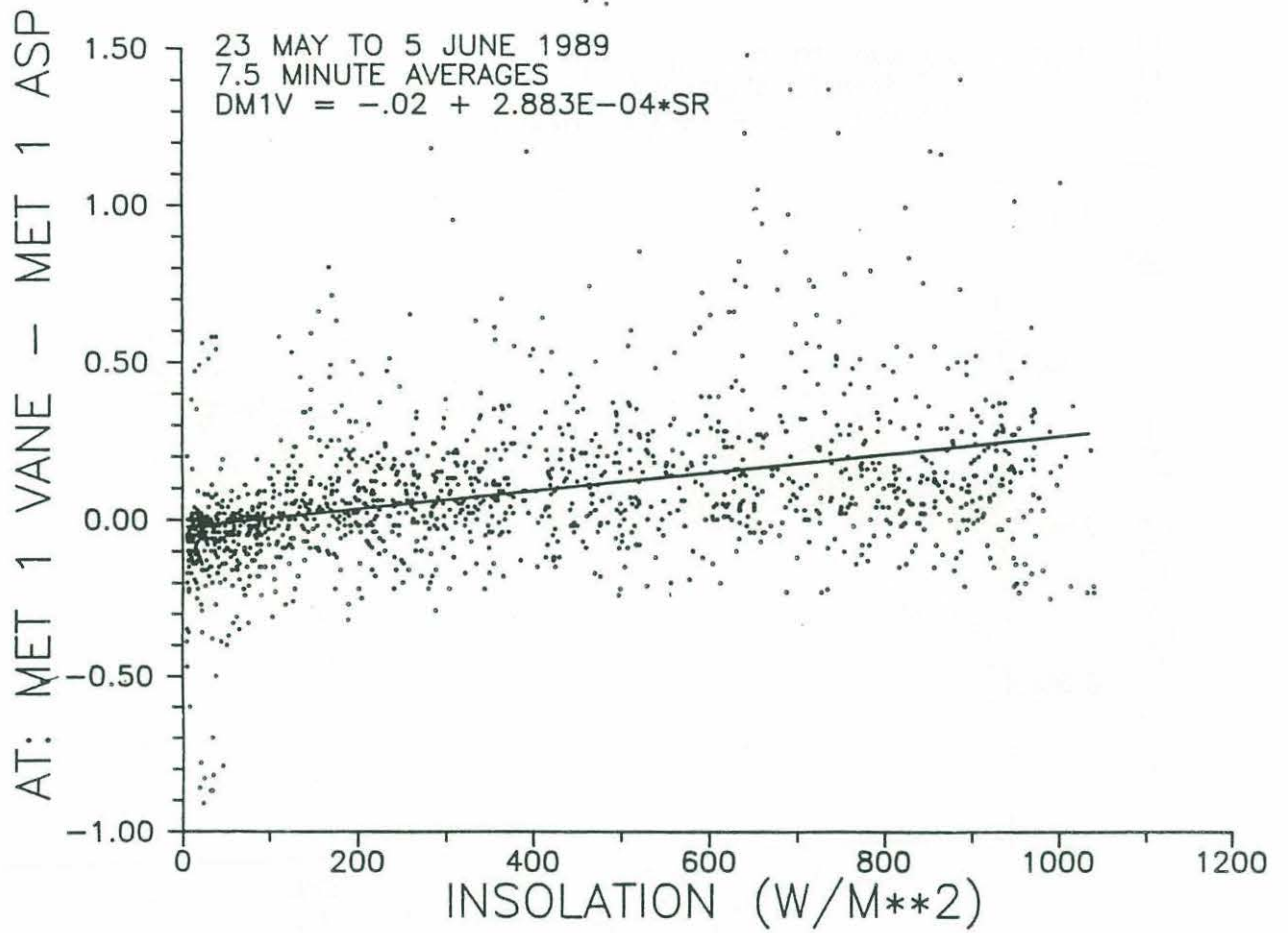

Figure 11: Scatter plot of Met One vane minus Met One Aspirated air temperature as a function of insolation.

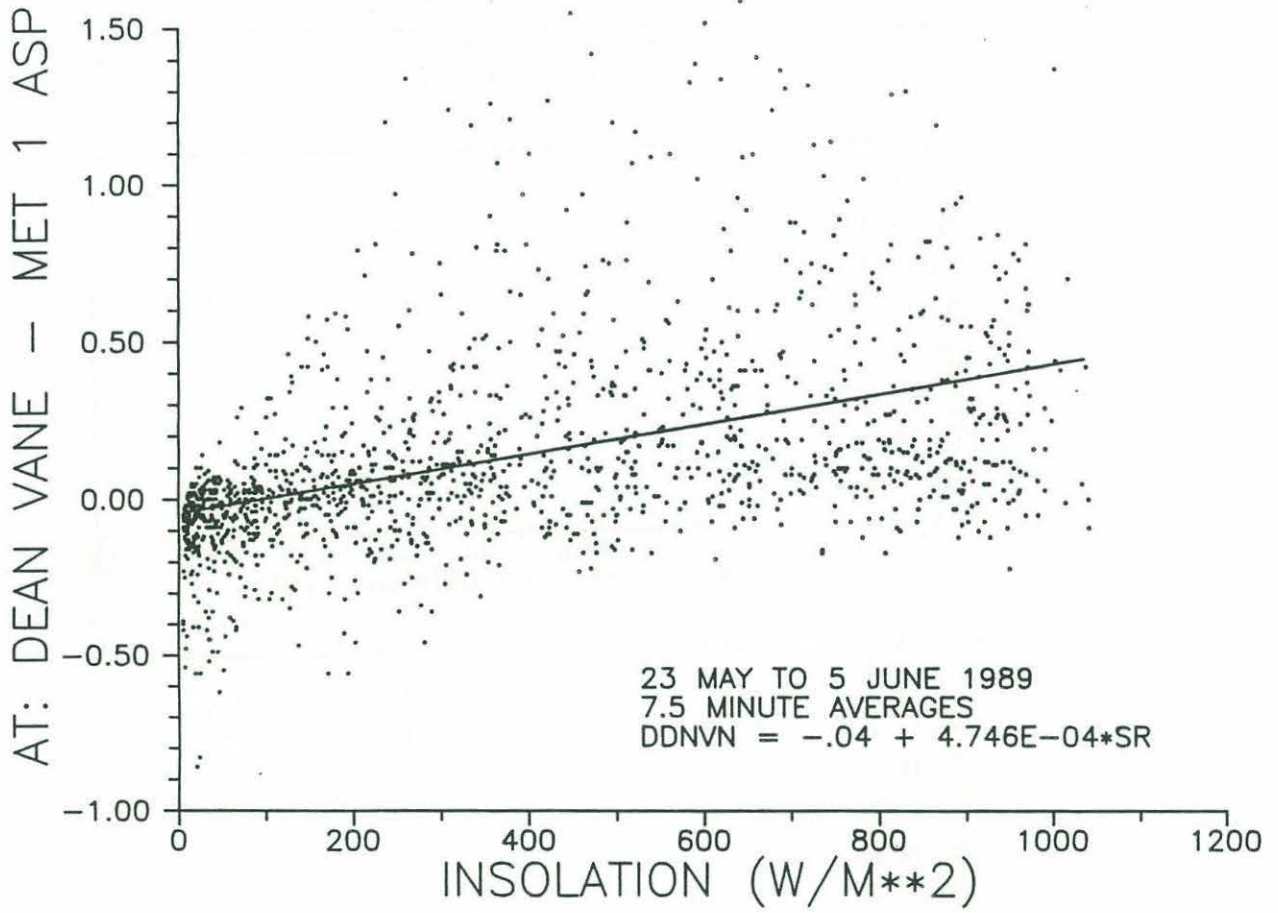

Figure 12: Scatter plot of WHOI vane minus Met One Aspirated air temperature as a function of insolation.

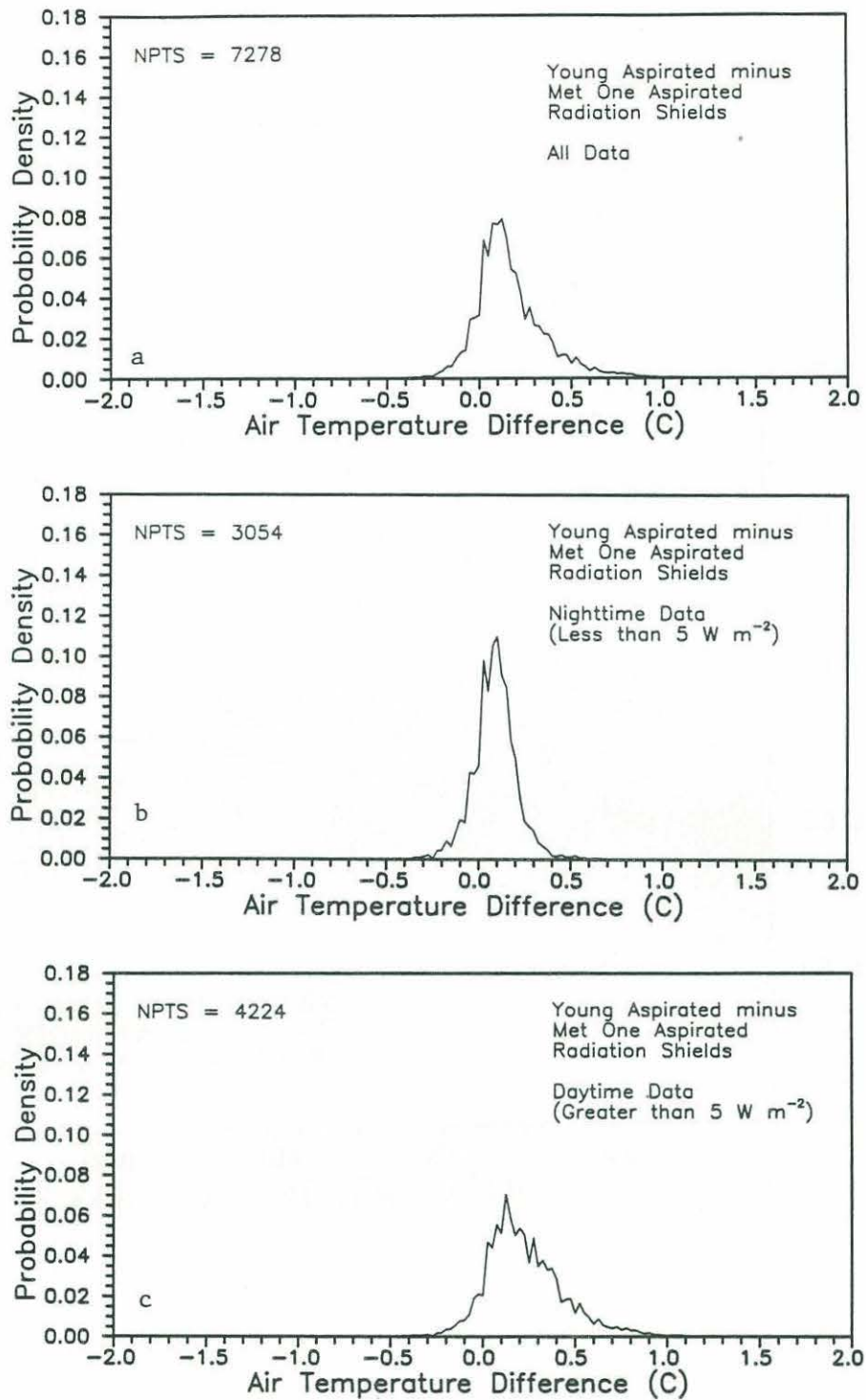

Figure 13: Probability density of R. M. Young Aspirated minus Met One Aspirated air temperature for (a) all data, (b) nighttime data, and (c) daytime data.

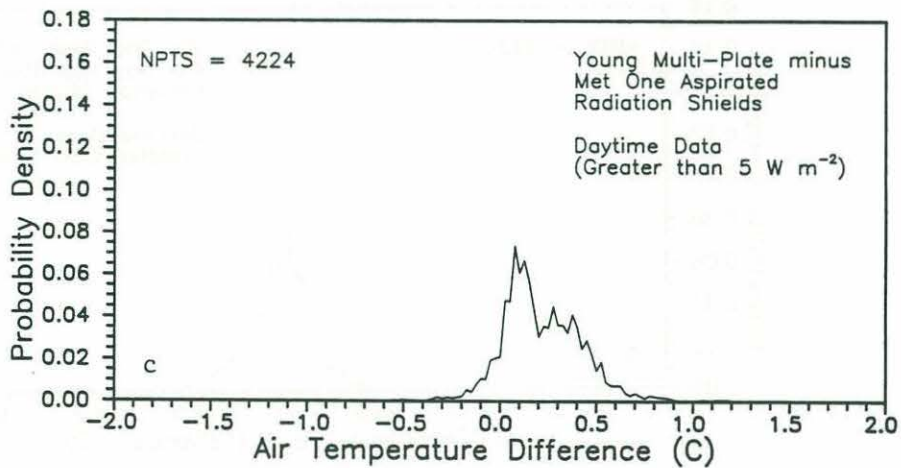
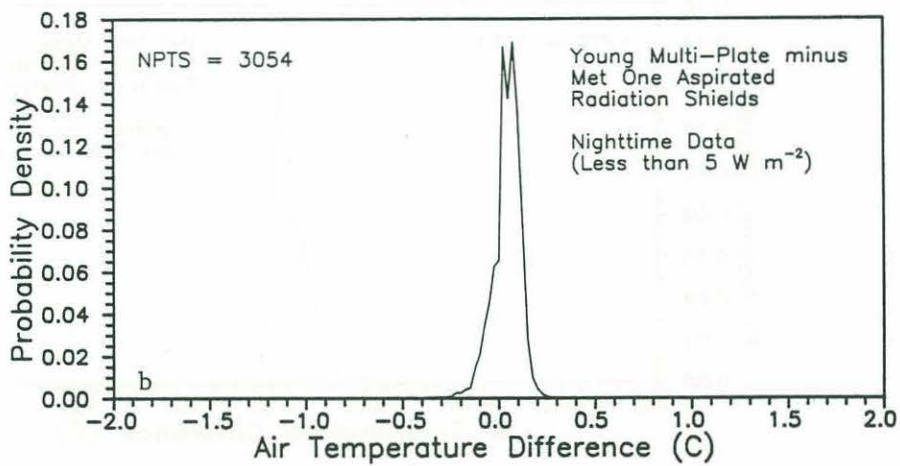
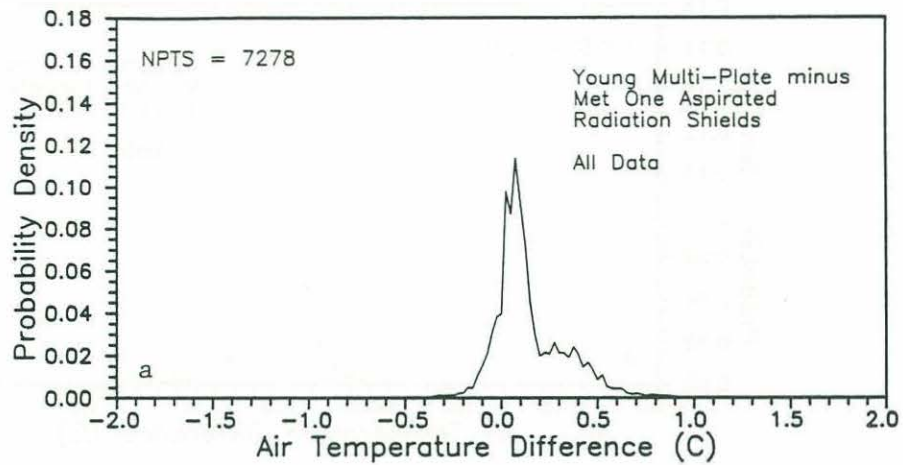

Figure 14: Probability density of R. M. Young multi-plate minus Met One Aspirated air temperature for (a) all data, (b) nighttime data, and (c) daytime data.

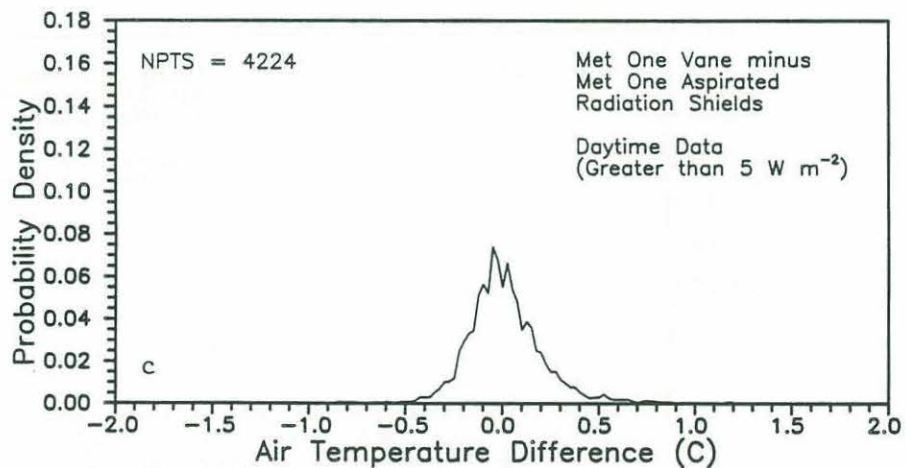
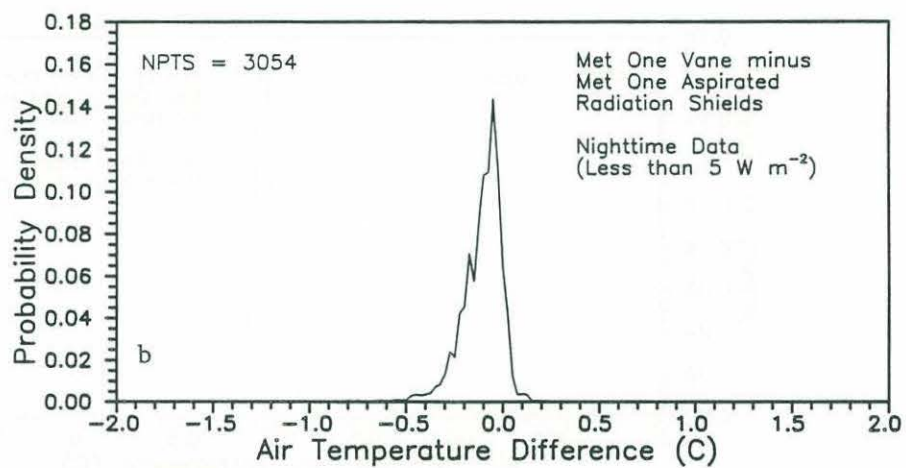
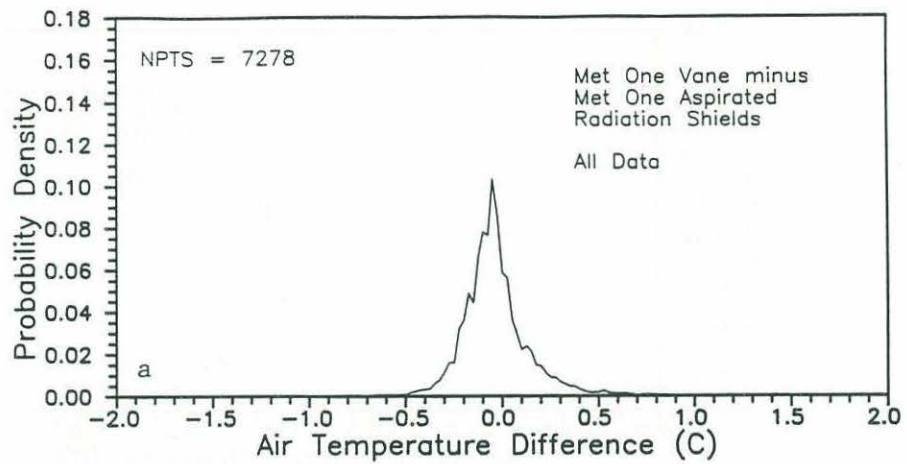

Figure 15: Probability density of Met One vane minus Met One Aspirated air temperature for (a) all data, (b) nighttime data, and (c) daytime data.

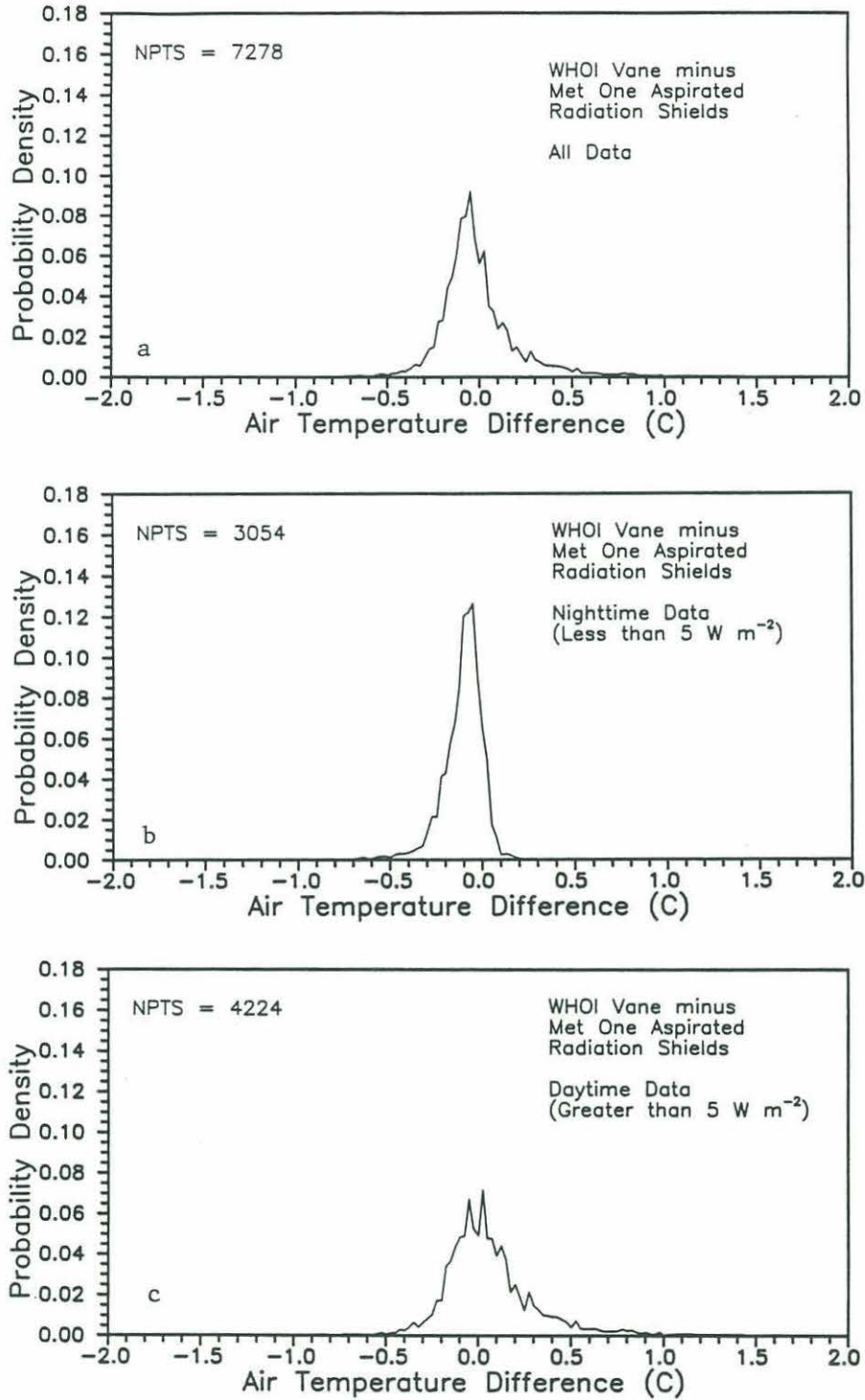

Figure 16: Probability density of WHOI Vane minus Met One Aspirated air temperature for (a) all data, (b) nighttime data, and (c) daytime data.

DOCUMENT LIBRARY

July 5, 1989

Distribution List for Technical Report Exchange

Attn: Stella Sanchez-Wade
Documents Section
Scripps Institution of Oceanography
Library, Mail Code C-075C
La Jolla, CA 92093

Hancock Library of Biology &
Oceanography
Alan Hancock Laboratory
University of Southern California
University Park
Los Angeles, CA 90089-0371

Gifts & Exchanges
Library
Bedford Institute of Oceanography
P.O. Box 1006
Dartmouth, NS, B2Y 4A2, CANADA

Office of the International
Ice Patrol
c/o Coast Guard R & D Center
Avery Point
Groton, CT 06340

Library
Physical Oceanographic Laboratory
Nova University
8000 N. Ocean Drive
Dania, FL 33304

NOAA/EDIS Miami Library Center
4301 Rickenbacker Causeway
Miami, FL 33149

Library
Skidaway Institute of Oceanography
P.O. Box 13687
Savannah, GA 31416

Institute of Geophysics
University of Hawaii
Library Room 252
2525 Correa Road
Honolulu, HI 96822

Library
Chesapeake Bay Institute
4800 Atwell Road
Shady Side, MD 20876

MIT Libraries
Serial Journal Room 14E-210
Cambridge, MA 02139

Director, Ralph M. Parsons Laboratory
Room 48-311
MIT
Cambridge, MA 02139

Marine Resources Information Center
Building E38-320
MIT
Cambridge, MA 02139

Library
Lamont-Doherty Geological
Observatory
Columbia University
Palisades, NY 10964

Library
Serials Department
Oregon State University
Corvallis, OR 97331

Pell Marine Science Library
University of Rhode Island
Narragansett Bay Campus
Narragansett, RI 02882

Working Collection
Texas A&M University
Dept. of Oceanography
College Station, TX 77843

Library
Virginia Institute of Marine Science
Gloucester Point, VA 23062

Fisheries-Oceanography Library
151 Oceanography Teaching Bldg.
University of Washington
Seattle, WA 98195

Library
R.S.M.A.S.
University of Miami
4600 Rickenbacker Causeway
Miami, FL 33149

Maury Oceanographic Library
Naval Oceanographic Office
Bay St. Louis
NSTL, MS 39522-5001

Marine Sciences Collection
Mayaguez Campus Library
University of Puerto Rico
Mayaguez, Puerto Rico 00708

REPORT DOCUMENTATION PAGE	1. REPORT NO. WHOI-89-46	2. IMET TR-89-03	3. Recipient's Accession No.
4. Title and Subtitle Improved Meteorological Measurements from Buoys and Ships (IMET): Preliminary Analysis of Solar Radiation Air Temperature Shields.		5. Report Date October, 1989	
7. Author(s) Gennaro H. Crescenti, Richard E. Payne and Robert A. Weller		8. Performing Organization Rept. No. WHOI-89-46	
9. Performing Organization Name and Address The Woods Hole Oceanographic Institution Woods Hole, Massachusetts 02543		10. Project/Task/Work Unit No.	
		11. Contract(C) or Grant(G) No. (C) (G) OCE 87-09614	
12. Sponsoring Organization Name and Address The National Science Foundation		13. Type of Report & Period Covered Technical Report	
		14.	
15. Supplementary Notes This report should be cited as: Woods Hole Oceanog. Inst. Tech. Rept., WHOI-89-46, IMET TR-89-03			
16. Abstract (Limit: 200 words) Several different types of solar radiation air temperature shields are evaluated for use at sea on ships and buoys. They include three types of static or Thaller shields, two vane oriented shields, and two fan ventilated shields. A preliminary data analysis is presented and discussed.			
17. Document Analysis a. Descriptors 1. radiation shields 2. marine meteorological measurements 3. ship and buoy instrumentation b. Identifiers/Open-Ended Terms c. COSATI Field/Group			
18. Availability Statement Approved for publication; distribution unlimited.		19. Security Class (This Report) UNCLASSIFIED	21. No. of Pages 53
		20. Security Class (This Page)	22. Price