

Гідротранспортне обладнання гірничо-збагачувальних комбінатів має низьку експлуатаційну надійність, недостатній робочий ресурс через інтенсивний гідроабразивний знос робочих поверхонь трубопроводів і насосного обладнання, недоліки конструкцій деяких вузлів ґрунтових насосів та їх експлуатацію. Значний гідроабразивний знос основного елемента конструкції ґрунтового насоса – робочого колеса, викликає додаткові збуджуючі динамічні сили, що призводить до підвищеної вібрації агрегату і, отже, до передчасного виходу його з ладу. Питанням впливу гідроабразивного зносу робочого колеса ґрунтових насосів на термін служби їхніх установок і їхній ресурс, до теперішнього часу, приділялася недостатня увага.

Виконано аналіз прояву кавітаційного зносу деталей проточної частини ґрунтових насосів, намічені заходи зниження кавітації за рахунок сприятливих умов надходження рідини в насос і зниження вакууметричної висоти всмоктування. Запропоновано також ряд заходів технологічного та конструктивного рішення, зниження шкідливого впливу кавітації.

Обрані та проаналізовані матеріали для виготовлення деталей відцентрового ґрунтового насоса, що володіють високими експлуатаційними якостями, мають високий ресурс роботи. Ці сплави показали високу корозійну стійкість через високий вміст в них хрому.

Намічено шляхи вдосконалення конструкції деталей відцентрового ґрунтового насоса, що дозволяє підвищити ресурс їхньої роботи, створити автоматизовану систему діагностування стану конструкції в цілому

Ключові слова: ґрунтовий насос, робоче колесо, бронедиск, гідроабразивний знос, дроселювання, вимірювальний стенд

UDC 621.671

DOI: 10.15587/1729-4061.2019.180791

IMPROVEMENT OF THE DESIGN OF HYDRAULIC TRANSPORT DEVICES FOR THE TRANSPORT OF HYDROABRASIVE MEDIA IN THE ENRICHMENT INDUSTRY

A. Seitkhanov

Doctoral Student

Department of Industrial Engineering

Satbayev University

Satpaev str., 22a, Almaty, Republic of Kazakhstan, 050013

E-mail: azamat__86@mail.ru

V. Povetkin

Doctor of Technical Sciences, Professor*

E-mail: vv1940_povetkin@mail.ru

B. Bektibay

PhD, Professor*

E-mail: bektibaybirzhan@mail.ru

M. Tatybayev

PhD, Associate Professor

Department of Technology and Food Safety

Kazakh National Agrarian University

Abai ave., 8, Almaty, Republic of Kazakhstan, 050010

E-mail: mukhtar_t.k@mail.ru

A. Bukayeva

PhD, Teacher

Department of Mechanical Engineering and Transport

Yessenov University

32 microdistricts, Aktau, Republic of Kazakhstan, 130003

E-mail: amina_bukayeva@mail.ru

*Department of Thermal Physics and Technical Physics

Al-Farabi Kazakh National University

al-Farabi ave., 71, Almaty, Republic of Kazakhstan, 050040

Received date 24.07.2019

Accepted date 27.09.2019

Published date 23.10.2019

Copyright © 2019, A. Seitkhanov, V. Povetkin, B. Bektibay, M. Tatybayev, A. Bukayeva

This is an open access article under the CC BY license

(<http://creativecommons.org/licenses/by/4.0>)

1. Introduction

Ground pumps are mass units for the transport of crushed ore in aqueous media. The formed water abrasive medium has a high destructive capacity, so that the ground pumps, due to the intensive wear of working parts, have a low service life [1–3].

The service life of parts of the pump-armored disk, impeller, does not exceed 20 days of work, after which it is neces-

sary to stop the pump and carry out repair work to replace worn parts. That requires considerable losses of working time of the basic equipment of concentrating manufacture and a large volume of spare parts [2].

Therefore, the research aimed at developing a new ground pump design, with increased service life, is relevant.

The analysis of the problem of operation of ground pumps has shown that ground pumps at the enterprises of mining and processing manufacture do not meet the requirements

on reliability and power consumption indicators. The main drawback of ground pumps is the low service life of parts of the pump flow part due to the action of hydroabrasive and cavitation wear [1, 2].

Therefore, as a result of the research of mechanical and cavitation wear of impeller parts, the development of a new design of the ground pump with high resources of work is an urgent task.

2. Literature review and problem statement

The works of a number of foreign and Russian sources [3–7], design and technological decisions in the creation of effective ground pumps which consist in the following are analyzed:

- increased disc thickness in the area of maximum wear and through holes;
- the presence of an elastic band in the flow channel, which may fluctuate;
- the presence of grooves in the impeller blades, arranged in a certain order;
- use of a protective coating of high hardness material in the form of shells;
- formation of local turbulent flows, displacement of laminar flows from the periphery to the flow axis;
- reduced vibration due to intermediate supports;
- a way to reduce hydrodynamic friction by exposing the boundary layer of liquid or gas to an alternating electromagnetic field;
- changing the pipeline design from the inside – presence of longitudinal ribs with cylindrical segments fixed on them in order to reduce aerodynamic friction resistance and reduce the thickness of the boundary layer;
- replaceable wear ring installed in the rotating pump assembly;
- the presence of resistant and wear-resistant rings, in order to hold the liquid film between them, as a result – reduced wear when the impeller rotates.

However, these measures did not solve the problem of increasing the service life of ground pumps and replacement of worn-out parts, which takes a long time. The reason for this may be objective difficulties associated with the lack of original solutions of constructive and technological nature, which makes appropriate research impractical.

An option to overcome these difficulties may be that ground pumps are used in mass production, and the limits of ground pump improvement also depend on the hydrodynamic design parameters of the pulp movement in hydroabrasive media.

This is the approach used in the works [8–10], but there are problems with the surface roughness of the working disk.

All this makes it possible to assert that it is expedient to conduct a study on the improvement of the impeller and armored disk design as the most important loaded parts of the pump.

From the works, on the theme of hydroabrasive media transportation, it is possible to allocate researches where the condition of hydrotransport systems of some concentrating factories is analyzed. In [3], it is shown that in connection with the obsolescence of technological equipment, the main reason of failures in the work of hydrotransport of tails is insufficient reliability of pump units due to which there are up to 79 % of failures of the equipment.

In [4, 5], extensive researches of hydroabrasive wear in industrial and laboratory conditions in which the theoretical analysis of the wear process is combined with laboratory researches and pilot tests are resulted.

Of great interest for further study of the process of hydroabrasive wear are also theoretical and experimental studies carried out by the authors [6].

When working on hydraulic mixtures with small solid inclusions, the slot seals located at the inlet side of the impeller and the working surfaces of the blades and their inlet areas are wearing out most quickly.

At work on hydraulic mixes with large solid inclusions, the entrance sites of blades are exposed to the most intensive wear, with practically no wear of other sites of an impeller and consolidations. Wear of the input elements of the blade affects the deterioration of suction capacity and reduction of the head [7–9].

Assessment of hydroabrasive wear of ground pump parts allows to identify significant ways to reduce it by changing the design of the pump and creating an automated system to assess the state of wear, that is, permanent diagnosis [10].

One of the essential phenomena influencing the wear of ground pump parts is cavitation [11].

During cavitation, there is a drop in supply, head, efficiency and power, erosion of wheel wall material, housing and metal corrosion in the cavitation zone. The methods of reducing the wear of working parts of pump units, given in the cited literature [3–11], did not lead to a cardinal solution to the issue of increasing the service life.

Thus, all these types of wear lead to the destruction of the pump operating elements, deterioration of performance characteristics. Therefore, the improvement of the pump components design, providing the increase of wear resistance and regulation of the pump unit operation mode, are actual.

3. The aim and objectives of the study

The aim of the study is to substantiate the process of water-abrasive wear of ground pumps, to outline the ways of its reduction.

To achieve this aim, the following objectives are accomplished:

- to analyze the problems of ground pumps operation;
- to develop constructive measures to increase the service life of the ground pump and its parts;
- to conduct pilot tests of ground pumps.

4. Analysis of the problem of operation of ground pumps

Pumps wear out due to the contact of solid particles moving in the liquid with the walls of the pump flow channels. The impeller separates the particles by their particle size. Larger particles, whose trajectories are coarser than the liquid current lines, do not fall on the working surface of the blades at all. The blade flows only through the flow of small solids suspended in it.

The process of water-abrasive wear of pumps is a consequence of the total effect of all types of destruction: abrasive, cavitation, erosion and corrosion.

As a result of water-abrasive wear, impellers, armored discs and pump housings (snails) are most often replaced at mining and processing plants.

Catastrophic sizes of hydroabrasive destruction of pump impellers testify to the big destroying ability of water flow containing abrasive particles [12, 13]. Fig. 1 shows fragments of a new and worn pump impeller.



Fig. 1. Ground pump impeller 8Gr-8:
a – new impeller; b – worn-out impeller

Hydroabrasive abrasion of ground pump parts is determined by the formula [14]:

$$\Delta_a = \Delta\rho \frac{\pi d^3}{12g} \rho_T v_T^2 n_p \sin \alpha, \tag{1}$$

where $\Delta\rho$ – the coefficient taking into account the strength of the wear part material and abrasive properties of solid particles; $\pi=3.14$; d – average particle diameter of solid, mm; v_T – solid speed, m/s; ρ_T – solid density, t/m³; g – freefall acceleration, m/s²; α – attack angle, degrees; n_p – number of particles colliding with the wearing surface per unit of time.

Non-ferrous metallurgical enterprises have adopted a classification of hydro-mixtures, according to which they are divided into four categories depending on the properties of solid particles (Table 1).

Table 1

Classification of hydromixtures adopted by non-ferrous metallurgical enterprises

Hydro-mixture category	Mass concentration of solids, % inclusive	Particle hardness on the Mohs scale	Particle size, mm	Hydro-gen index, pH
I	Up to 25	Less than 2 2...3 3...4 4...5	More than 8 8...3 3...1 1 and less	6...8
II	25 to 35	Less than 3 3...4 4...5 5...6	More than 8 8...3 3...1 1 and less	6...8
III	35 to 45	Less than 4 4...5 5...6 6...7	More than 8 8...3 3...1 1 and less	6...8
IV	45 to 65	Not regulated	Not regulated	6...10

The main parameters of the hydraulic mixtures flows characterize their physical and mechanical properties and the conditions of the steady flow in the pump. The main physical and mechanical properties of hydro-mixtures include: solid content (volume S or mass S_1); specific gravity γ , kN/m³; pseudo viscosity μ , N·s/m² (for dispersed or finely dispersed mixtures) [15].

In terms of the predominant content of solid particles of a certain particle size class, the following main types of hydro-mixtures can be identified:

- colloidal (atypical) – with a particle size of up to 1 μ m;
- structural (hydrosols) – particle size 1–50 μ m;
- fine – particle size 50–150 μ m, obtained in the processes of sedimentation and grinding;

- coarse dispersion – particle size from 100 μ m to 2 mm, obtained in the processes of sedimentation and grinding;
- heterogeneous coarse dispersions – particle size greater than 1.5–2 mm;
- polydisperse – particles of various sizes obtained in the processes of sludge accumulation, dispersion, crushing or crushing.

In ferrous and non-ferrous metallurgy concentrators, mixtures with a predominant content of particle classes typical of fine and coarse-disperse systems are most often found [15].

Surfaces are destroyed by continuous impacts transported by a stream of particulate matter to the surface of the component. At the moment of impact, the deformation of the material in the flow of the part is transformed.

Countless collisions of the solids transported by the flow with the surface of the part, even if they cause only elastic deformations of the material, also lead to the eventual destruction of the surface due to fatigue phenomena of the metal. The liquid medium has a de-strengthening effect, thus accelerating the process of fatigue failure [15].

As the pump wears out, mechanical losses also increase. As a result of increased leakage, the flow regime in the area between the machine wheel and the housing changes, which can cause a significant increase in disc friction losses. In addition, the inevitable unevenness of wheel wear can cause imbalance, which in turn leads to the destruction of bearings, one-sided wear of the shaft and causes intense vibrations that reduce the mechanical efficiency of the pump [16].

It is established that after processing of about 100 thousand m³ of hydromixture by the pump, its head and supply decreased by 50 % on average, while the specific power consumption per 1 m³ of transported abrasive material increased by more than 2 times (Fig. 2–4) [17].

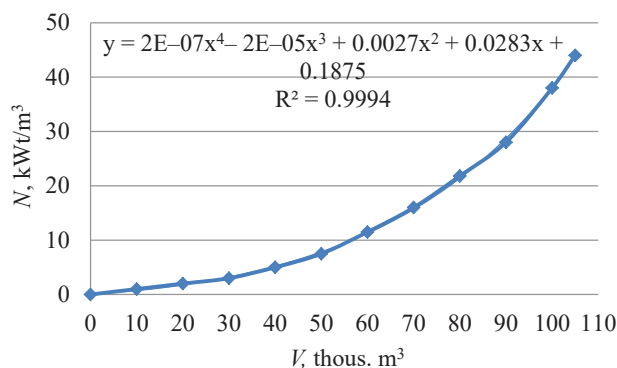

Fig. 2. Dependence of specific power consumption on the volume of abrasive material processed

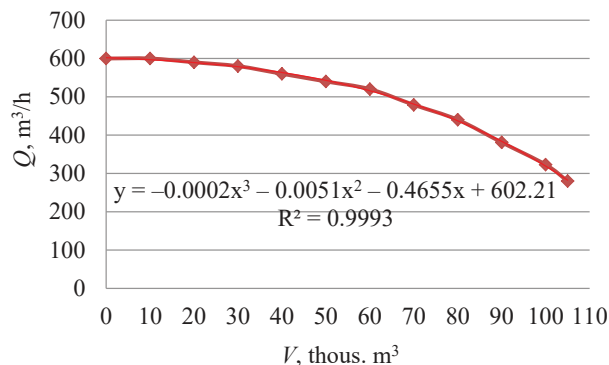

Fig. 3. Dependence of pump flow rate on the volume of processed abrasive material

As the volume of V , the abrasive material processed, and therefore the wear of the ground pump parts increases, the pressure H , the flow Q is sharply reduced. The analysis of the given dependences shows that the duration of the ground pump overhaul period should be determined by the loss of mass due to wear and tear. But also on the decrease of the basic indicators of pump operation (H, Q) (Fig. 4) [18].

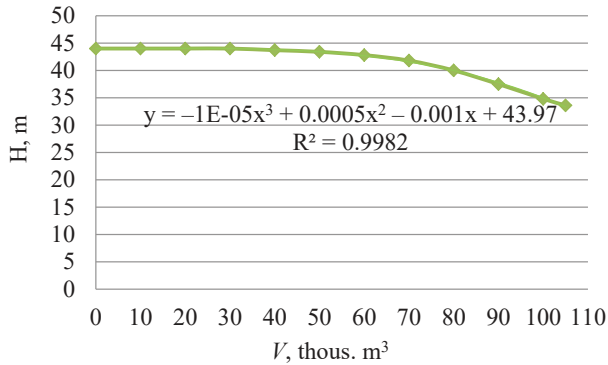

Fig. 4. Dependence of pump head on the volume of processed abrasive material

As a result of modeling the process of pumping units operation, using multifactor experiment and computer programs Excel planning and processing of experimental data, the equations of regression allowing to determine:

- specific power consumption from the volume of processed abrasive material, $y = 2E-07x^4 - 2E-05x^3 + 0.0027x^2 + 0.0283x + 0.1875$, $R^2 = 0.9994$;
- pump feed rate from the volume of abrasive material processed, $y = -0.0002x^3 - 0.0051x^2 - 0.4655x + 602.21$, $R^2 = 0.9993$;
- pump head from the volume of abrasive material processed, $y = -1E-05x^3 + 0.0005x^2 - 0.001x + 43.97$, $R^2 = 0.9982$.

Regression equations of pump units operation processes are shown in Fig. 2–4, which allows to make corresponding calculations. Hydroabrasive wear of the ground pump impeller and other parts of the pump is the main reason for the reduction of the service life of the pump itself and the entire hydraulic transport system. The development of hydroabrasive wear of the impeller surfaces is accompanied by a change in the vibration spectrum at the main support units of the pumping unit. Excess oscillations of the pump casing are transferred to the support units, which can support significant alternating dynamic loads, leading to their destruction.

If the actual Q_A flow and H_A pressure of the pump unit, as defined at operating point A, do not meet the specified conditions, the operating mode of the installation changes:

1) Throttling by means of a regulator. When it is partially closed, the hydraulic losses in the pipeline increase by the value h_o . The required head of the pumping unit increases (Fig. 5, a):

$$H'_{pipes} = H_F + K_c Q^2 + h_o = H_F + K'_c Q^2, \quad (2)$$

where K'_c – network resistance coefficient with additional throttling. The working point will move to the point B. The pump supply will be reduced.

The method is simple in execution, but accompanied by power losses:

$$N_l = \rho g h_o \frac{Q_B}{\eta_B}, \quad (3)$$

2) By bypassing a part of the liquid (Q_{per}) from the pressure line to the suction (or tank) through the bypass line.

3) Changing the characteristics of the pump itself, e.g. changing the pump shaft speed (Fig. 5, b).

Speed control can be achieved by using a DC motor, combustion engine or turbines.

4) Changing the characteristics of the pump itself by turning the impeller, i.e. reducing the output diameter ($D_2^1 < D_2$). The geometric similarity of the wheels is broken, the conversion formulas are semi-empirical:

$$\frac{Q}{Q'} = \left(\frac{D_2}{D_2'}\right)^x; \quad \frac{H}{H'} = \left(\frac{D_2}{D_2'}\right)^g; \quad \frac{N}{N'} = \left(\frac{D_2}{D_2'}\right)^z, \quad (4)$$

where Q', H', N' are pump parameters after turning.

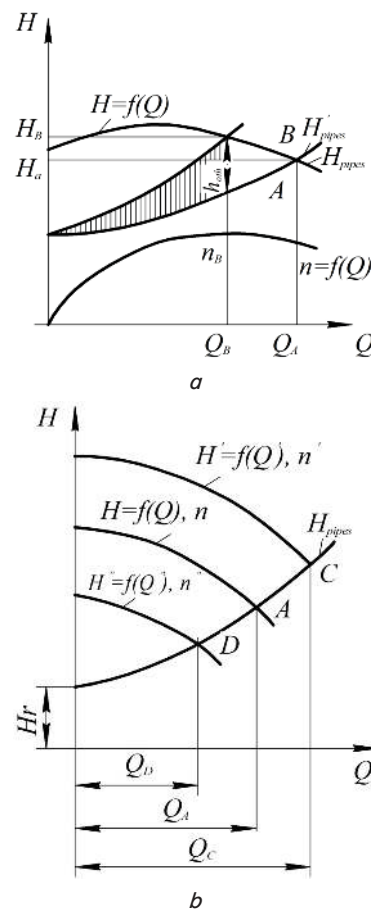

Fig. 5. Changing the working point position: a – throttling; b – speed change

In order not to cause an excessive reduction in efficiency, the turning value should not exceed 7...20 % of the normal wheel diameter. Greater turning (up to 20 %) is allowed at $n_s=60$; smaller at $n_s=350$.

5. Working out of actions of constructive character on increasing the service life of the ground pump and its parts

To increase the service life of ground pumps, it is proposed, depending on the design of the pump, to produce impellers

in the composite form [19]. The impellers can be manufactured in different ways:

- a wheel consisting of: two disks of the master and slave and n -th number of blades (Fig. 6);
- a wheel consisting of two parts: a driving disc with blades, made in the form of an open impeller and a driven disc.

Parts are connected by means of screws 4 or pins 5 (Fig. 6) with diameter $d=0.3b$, where b is the average thickness of the impeller blade.

Thus, the production of the impeller as a composite impeller makes it possible to process the internal curvilinear impellers. And also to cover them before assemblage with the special covering protecting them from corrosion, cavitation and hydroabrasive deterioration that is difficult to carry out in the closed wheel. Restoration of the protective coating and replacement of worn-out parts will reduce the cost of purchasing pump spare parts and extend the life of the pump until overhaul.

Fig. 7 shows a modernized ground pump containing a casing, a composite impeller and an armoured disc, and a clear water flushing system that flows directly into the gap between the armoured disc and the impeller. The 1/2-diameter armoured disc is equipped with a removable disc made of wear-resistant material [20].

The armoured disc is a characteristic feature of the Discs class. Parts in this class must be manufactured to the required shape and dimensional accuracy of the outer, inner and end faces of rotation. The part under consideration is rigid enough, has convenient base surfaces and does not cause any technological difficulties in its manufacture.

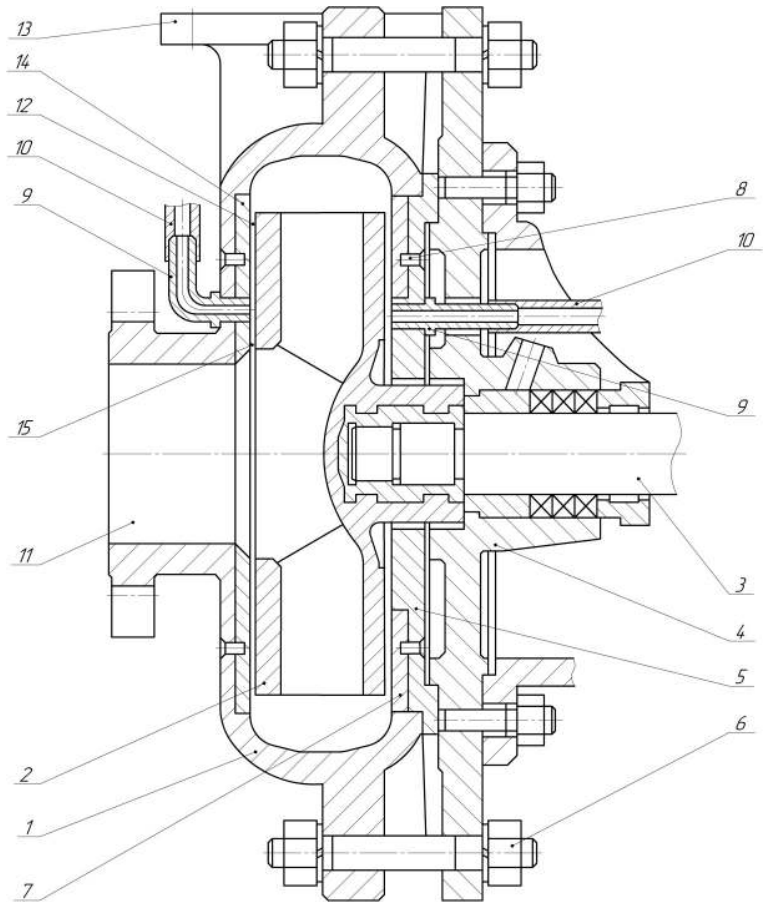

Fig. 7. Slitting of the working part of the ground pump with increased wear resistance: 1 – pump casing, 2 – impeller, 3 – shaft, 4 – support cup, 5 – armoured disc, 6 – pump mounting, 7 – removable disc, 8 – removable disc mounting, 9 – inlet fitting, 10 – flexible hose, 11 – suction cavity, 12 – slotted cavity, 13 – volute outlet, 14 – armour plate, 15 – cuff

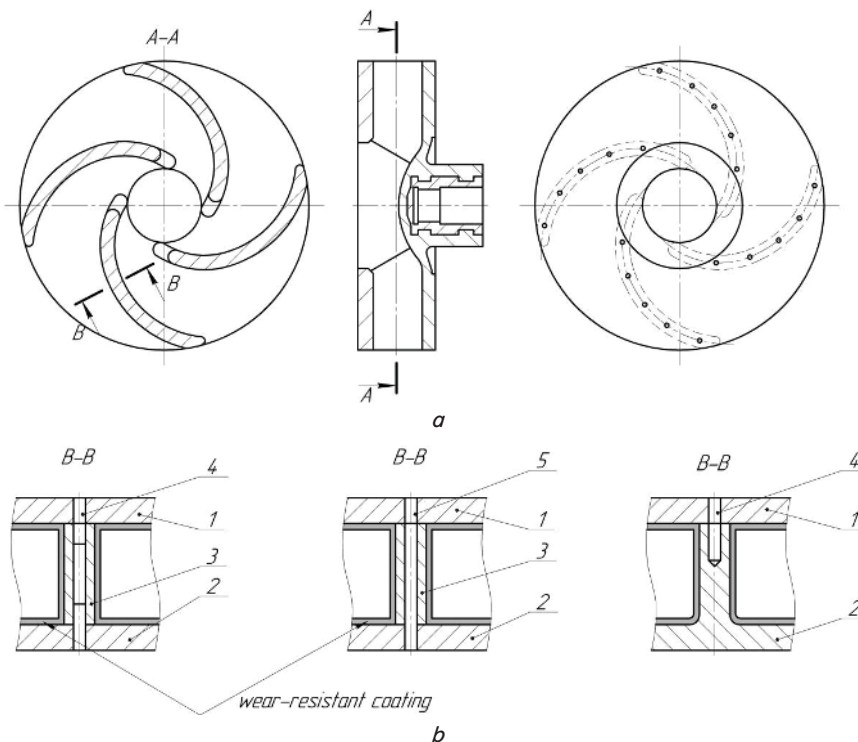

Fig. 6. Pump impeller assembly: *a* – pump impeller; *b* – variants of the assembly wheel

It is proposed to install a clear water flushing system in the ground pump, which flows directly into the gap between the armoured personnel carrier and the impeller. The 1/2-diameter armoured disc is equipped with a replaceable disc, the working surface of which is reinforced with a wear-resistant material, which makes it possible to restore it from hydro-abrasive wear without replacing the armoured disc (Fig. 8).

To prevent wear of wheel 2 and armoured disc 5, the latter is made with a composite wear-resistant replaceable disc 7. Pure water is supplied to the gap 12 through the fitting 9 and the hose 10 under the pressure of 0.1–0.2 MPa, exceeding the pressure in the pump pressure connection. The upper part of the impeller is equipped with a sealing collar 15.

On the inner surface of the case 1 there is a similar replaceable armour plate 14, which is connected to the case with the help of screws.

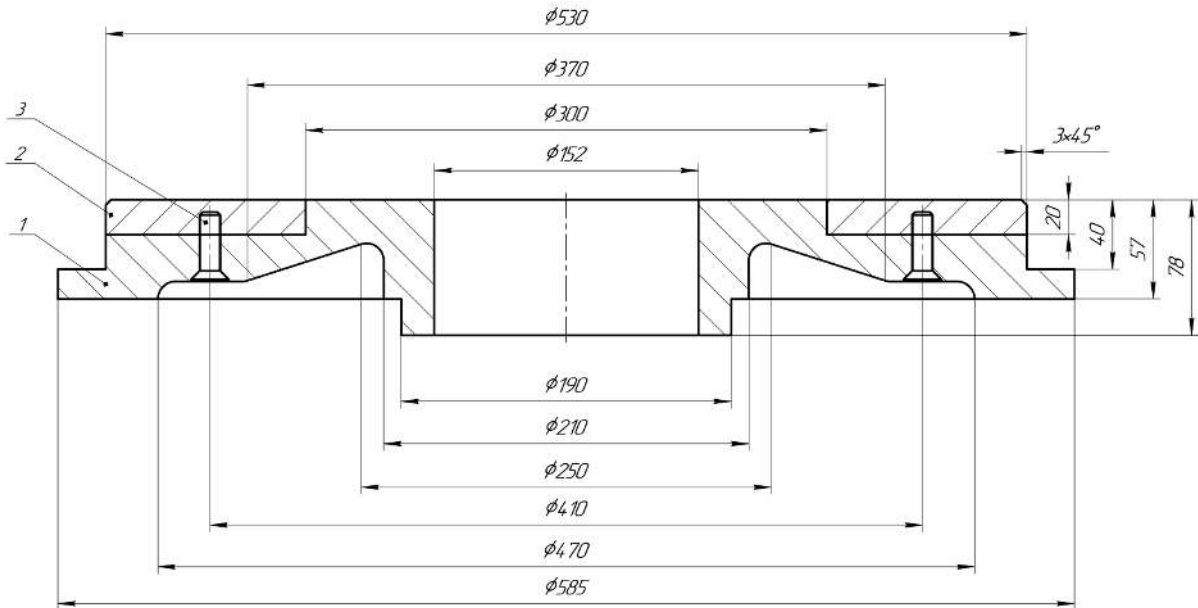

Fig. 8. Assembly drawing of the proposed prefabricated armored personnel carrier on the example of a pump armored disc 8Gr-8T: 1 – main disc, 2 – replaceable disc, 3 – screw

Water is also supplied to the gap between the removable armour plate 14 and the impeller. A cuff is installed in the lower part of the replacement armored personnel carrier.

The assembly drawing of the composite armored disk on the example of the 8Gr-8T pump armored disk is shown in Fig. 8.

Thus, the use of replaceable discs will allow you to quickly restore worn parts, and the use of sealing sleeves and clear water flushing systems allows you to significantly increase the service life of working parts of the pump.

6. Development of an experimental stand for ground pump testing

For the design and technological improvement of the ground pump and its parts, a comprehensive study on the wear resistance and maintainability has been carried out. For this purpose, an experimental laboratory stand (Fig. 9) was developed, consisting of ground pump 1, electric drive 2, consumable tank 3, suction pipe 5, discharge pipe 4.

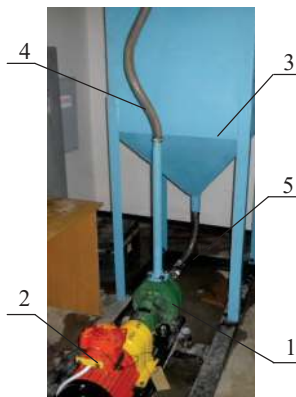

Fig. 9. Experimental laboratory stand for ground pump testing: 1 – pump, 2 – electric drive, 3 – pressure tank, 4 – discharge line, 5 – suction line

Laboratory tests of the pump included pumping of the hydraulic mixture through the ring pipeline and, after passing through the pump, the hydraulic mixture was returned to the consumable tank 3.

As a result of the research of the laboratory sample of the pump it is found out that, basically, the destruction of the impeller is connected with the wear of the blades, leading to the change of their configuration, as well as to their possible shortening.

When designing pumps, a number of features of their work are considered. For reducing the abrasive action of particles, parts of pumps are made of wearproof materials, and the thickness of walls of the case, disks, blades and other parts is chosen taking into account deterioration.

The main requirement and reliability is the service life of the ground pump. The main part of spare parts are impellers – up to 50 %, armored discs account for 25 %, branches and other parts 25 %.

In order to significantly reduce the wear and tear of hydraulic abrasive mixtures, it is proposed to apply fundamentally new approaches:

1. Create a vibration effect on the transporting device.
2. Create a vibration impact directly on the transported mixture.

Vibratory impact on the mixture causes a significant decrease in the viscosity of the mixture, breaks the bonds between the particles of the mixture and sharply reduces the contact interaction of the mixture particles with the working bodies and bodies of transporting devices. As a result, abrasive wear and tear of conveying devices is reduced and the service life of pumps is increased accordingly.

The vibration parameters monitoring, regulated by the industry and international standards, is based on the statistical data on slurry pumps failures at the mining and processing plants. That is, in the process of operation, it is possible to predict the residual life of pumping units, as a function of water-abrasive wear of the impeller [21].

In addition to the vibrating effect on the conveyed mixture, the vibrating effect of the pump mass caused by the

rotor unbalance should be reduced, resulting in intensive wear and tear on the shaft bearings.

The first includes such means of protection as dynamic balancing, antiphase synchronization, changing the nature of disturbing influences, changing the structural elements of the source of excitation, changing the frequency of vibrations, etc. They are used, as a rule, at the stage of designing and manufacturing of equipment [22].

Vibration isolation is carried out by means of introduction of additional elastic bonding into the vibrating system, which prevents the transmission of vibrations from the machine – the source of vibration – to the base or adjacent elements of the structure. This elastic connection can also be used to weaken the transmission of vibrations from the base to the person, or to the protected unit.

Vibration isolation is achieved by installing the units on special elastic devices (supports) with low rigidity.

The effectiveness of vibration isolation is evaluated by the transfer coefficient, which has a physical meaning of the ratio of force acting on the base in the presence of elastic bonds to the force acting in the case of rigid bonds. The smaller the ratio, the better the vibration isolation. Good vibration isolation is achieved with $KP=1/8-1/15$ [6].

The transfer coefficient can be calculated using the formula:

$$KP = \frac{1}{\left(\frac{f}{f_0}\right)^2 - 1}, \tag{5}$$

where f is the frequency of disturbing force; f_0 is the natural frequency of the system on vibration isolators. The optimal ratio between f and f_0 is 3...4.

For vibration isolation of machines with vertical perturbation force, 3 types of vibration isolating supports are used: rubber, spring and combined.

Installation of machines on spring shock absorbers is more effective than on rubber shock absorbers, as it provides lower natural frequencies of vibrating mechanism vibration [22].

The disadvantage of rubber shock absorbers is that they do not last long, as they become stiffer over time and after 5. They must be replaced after 7 years. In addition, they cannot be used to obtain very low intrinsic system frequencies, which are necessary for slow-moving units, due to the inevitable overload of gaskets, which significantly reduce their service life [22].

When designing parts of ground pumps it is necessary to accept the thickness of a rubber layer not less than 12–15 mm. Fig. 10 shows the dependence of the rubber layer wear rate on its thickness.

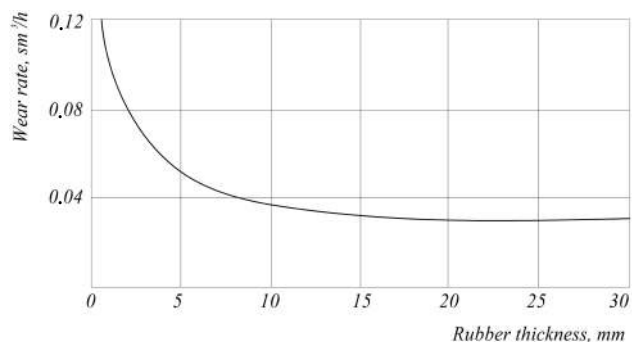

Fig. 10. Dependence of rubber layer wear rate on thickness

Weakening the vibration level:

$$\Delta L_u = 20 \lg \frac{1}{KP}, \tag{6}$$

where the KP is the transmission factor.

With the operation of the ground pump, in the hydraulic transport system, with the given kinematic characteristics of the pumped pulp, the spectrum of vibration parameters changes. The amplitude of vibrations in radial and axial directions gradually increases. Each moment of time, the ground pump working process, corresponds to its own values of vibration characteristics, i. e.

$$T = k_B \bar{V}^n, \tag{7}$$

where k_B is the proportionality coefficient, \bar{V} is the root-mean-square value of the vibration velocity, mm/s.

The energy required to move a unit of liquid weight from the receiving tank to the pressure tank, or the required head of the pumping unit:

$$H_{pipes} = h_r + \frac{(p'' - p')}{(\rho g)} + \sum h_n = H_r + K_c Q^2. \tag{8}$$

The vibration of the pumping units increases significantly with the increase of hydro-abrasive wear, with the maximum vibration movements taking place on the support bearings in the frequency range of 8–12 Hz. The development of vibration processes is directly related to the loss of weight of the ground pump impeller due to water-abrasive wear.

For measuring the received vibration, the measuring stand presented in Fig. 11 is developed, including the system of gauges, measuring means.



Fig. 11. Installation measuring system: 1 – electric motor, 2 – pump, 3 – vibrometer

Measuring instruments:

- Vibrometer VIP-UHL 4.2;
- working range of parts 10–100 Hz;
- measuring range:
 - a) Actual vibration velocity values of 01–100 mm/sec;
 - b) Vibration range – 01–1,000 microns;
- limits of measuring ranges:
 - a) vibration resistance 1, 3, 10, 30, ...100 mm/sec;
 - b) vibration displacement 10, 30, 100, 300, 1,000 microns;
- relative transverse conversion factor of the transducer does not exceed 10 %;

- basic relative error of vibration measurement under normal conditions is not used to:
 - a) 25 % when measuring the vibration range of 10–20 Hz;
 - b) 15 % when measuring the vibration velocity in the private range of 20–1,000 Hz;
- normal operating conditions:
 - a) ambient temperature is 20 plus, –5 °C;
 - b) relative humidity – 65±15 %;
 - c) atmospheric pressure – 100±4 kpa;
- scales electronic with accuracy to 5 g;
- a caliper with a measurement limit from 0 to 500 mm with an accuracy of 0,05 mm.

The centrifugal ground pump was tested on a hydro-mixture with 45 % of solid particles within 72 hours.

The entire pump design is evaluated for vibrations when the transducer (e. g. vibration displacement, vibration velocity or acceleration transducer) is placed at a specific point in the pump or on the mechanical part of the measuring stand that is mechanically connected to the pump parts.

The accumulated data is analyzed to find one or more parameters that are used to characterize vibration. These data can be used to determine the quality of the pump and its condition. The measurement process can be represented schematically as shown in Fig. 11.

The measured vibration parameter is the mean square value of the vibration velocity. The vibration signal can be presented as a vibration displacement, vibration velocity and vibration acceleration, as shown in Fig. 12.

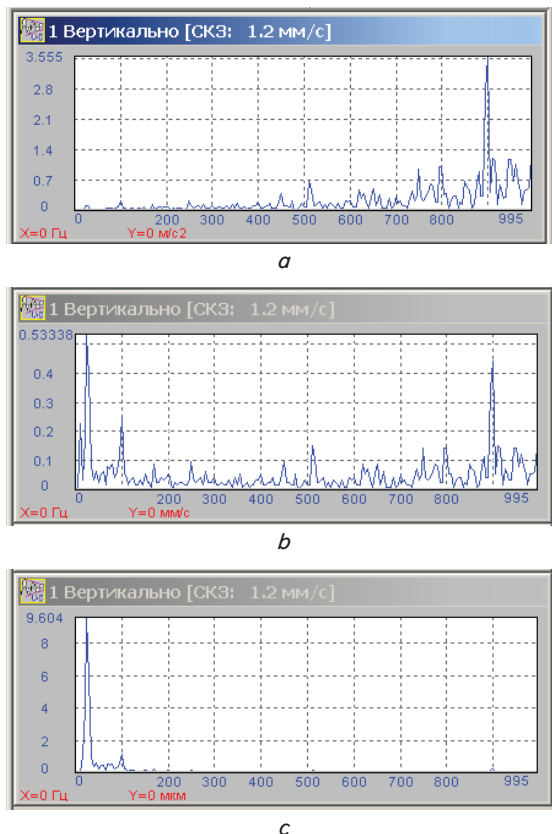

Fig. 12. Vibration signals:
 a – Vibratory movement; b – Vibration velocity;
 c – Vibroacceleration

With the operation of the ground pump *T*, the vibration, vibration velocity and vibration displacement of the pump

and its casing are increased. Amplitude spectra of vibrations have a maximum in the frequency band from 6 to 9 Hz. Energy saturation in the frequency band of 1 to 25 Hz is equal to 18.62, and in the area of 6–9 Hz energy is 50 % of the energy saturation of all frequencies. Dependence of vibration amplitude on pump operation time is shown in Fig. 13. The type of curves corresponds to the function (6).

The results of vibration measurement on one of the ground pump operation modes are shown in Fig. 13, where the dotted line shows the test results after 72 hours of operation.

Thus, implementation of diagnostics of the technical condition of pump units by vibrodiagnostics method allows to increase reliability and efficiency of ground pumps. Measurement and analysis of vibration signals can be used in the automated system of monitoring and control of technological processes (ASMC TP) of hydraulic transport systems, i. e. as part of the automated system the tasks of vibration diagnostics are solved.

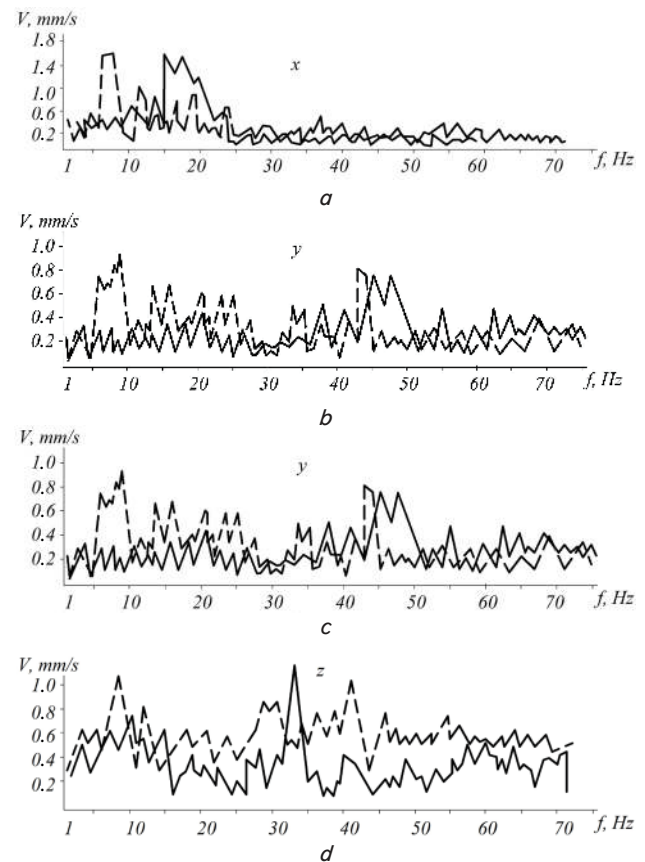

Fig. 13. Pump housing displacement velocities spectrograms:
 a – on the x-axis, b – on the y-axis, c – on the z-axis,
 — at the beginning of the test, - - - - at the end of the test

The vibrodiagnostics method allows to estimate the general technical condition by the average square value of the vibroscopic velocity. If necessary, an in-depth analysis of the technical condition of the equipment is carried out. To determine the reasons of vibration growth, i. e. to establish and eliminate defects (malfunctions) of pumping units, to increase the reliability of pumping units.

An important element of ground pump wear is cavitation wear [23]. Experimental studies of cavitation erosion have

shown that the streamlined surface within the cavitation zone is destroyed unevenly. The most significant surface areas are subject to wear and tear located at the end of the cavitation zone, where cavitation bubbles are destroyed at higher external pressure (Fig. 14).

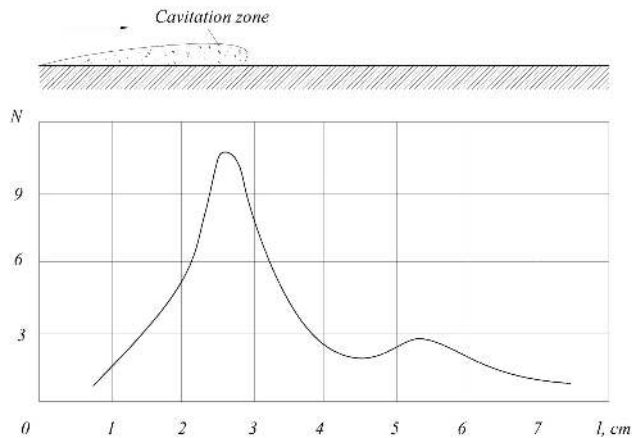

Fig. 14. Erosion distribution within the cavitation zone N – number of sinks per 1 cm^2

Measures to combat cavitation are reduced, first of all, to the elimination of the causes, i. e. to the creation of favorable conditions for the flow of liquid into the pump, as well as the reduction of vacuum gauge suction lift [21]:

- 1) correct choice of the static suction lift when working with cold liquid and the height of the support for hot liquid;
- 2) reduction of head losses on the suction line (by reducing the length and increasing the diameter of the pipes);
- 3) elimination of leaks in the suction pipes.

A more effective way to prevent cavitation is to increase the pressure in the flow area before entering the impeller by introducing water jets from the pressure pipe into the suction pipe. At the same time, the energy of the jet is transferred to the water flow at the inlet into the wheel, which leads to an increase in pressure in the considered section [25].

An effective measure to improve the cavitation properties of the pump is the installation of a first stage axial wheel or auger in front of the impeller.

The pre-installed wheel or screw creates additional support at the inlet to the impeller, providing its cavitation-free operation [25].

Analysis of used materials and wear-resistant coatings of wearing parts. The choice of materials for pump parts is based on a number of positions, some of which are in conflict with each other. For example, the mechanical properties of the material must ensure the strength of the part not only under normal operating conditions, but also under special operating conditions. Alloys K28N2(11), ICChN-2, ICChMoM2N, ICCh2MoT, ICCh15MT, ICCh16MoM, ICCh28N2 have proved to be wear-resistant materials for manufacturing parts of ground pumps. The water-abrasive wear resistance of these alloys is 10–15 times higher than that of grey cast iron. The main disadvantage of wear-resistant cast irons is their brittleness.

At present, the most widespread in practice is wear-resistant cast iron ICCh28N2. The disadvantage of ICCh28N2 cast iron is its high hardness after annealing due to the presence of residual austenite in the cast iron structure. High hardness of annealed cast iron ICCh28N2 creates difficulties

in machining. One of the advantages of the ICCh28N2 alloy in comparison with other wear-resistant alloys is better corrosion resistance due to its high chromium content.

ICCh16MT differs favorably from ICCh28N2 cast iron by its relatively low hardness in the annealed state and uniform fine distribution of structural components in the finally heat-treated state. Burned cast iron ICCh16MT has hardness HB 280-340 that provides its easier workability. The content of 0.5–1.0 % of titanium in ICCh16MT cast iron contributes to microstructure grinding, which ensures high wear resistance and satisfactory mechanical properties of the samples [25].

Table 2 presents comparative characteristics of wear-resistant alloys for manufacturing parts of centrifugal pumps operating under abrasion conditions.

Table 2

Characteristics of wear-resistant alloys

Alloy grade	Hardness, HRC	Wear resistance coefficient of steel 25	Processability factor
300Ch12M5	59–62	7.0	1.0
300Ch12M3Mo	61–62	8.5	–
300Ch12Mo	28–33	3.3	4.5
300Ch16MoT	60–61	10.0	4
300Ch28N2	47–55	7.3	1.0
ICCh28N2	35–50	5.0	2.0
250Ch25T	53–60	7.0	1.0

The ICCh28N2 alloy, which is widely used in pumping, is hard to machine on metal-cutting machines. It can be ground only with low cutting speed (8–10 m/min), and it is impossible to cut threads on parts made of this alloy and chisel key grooves at all.

At the request of VNIINedra, the impellers were tested cast of M13Ch2F steel. The service life of these impellers was 3 times longer in relation to the impellers cast from 55F steel [25].

Two grades of medium carbon low-alloy steels are recommended for industrial testing:

- chromium-manganese chromium-nickel (40ChMNF);
- chromium-nickel-tungsten-vanadium (35ChN1TVF).

7. Discussion of the results of ground pump research

The obtained results of the ground pump research are based on the real methods of solutions, both theoretical and experimental.

A distinctive feature of the proposed methods is the improvement of design and technological parameters of pumping units operation for transportation of pulp containing media in their originality and uniqueness.

The proposed development of ground pump parts, namely the impeller and armour wheel, to increase the service life of the pumping unit is obvious and requires industrial application. These design developments were claimed and inventions were received (Fig. 7, 8) [19, 20].

The pilot test resulted in positive results of the ground pump performance evaluation. Regression equations of pump units operation processes are presented in Fig. 2–4, which allows to make corresponding calculations.

The design decisions were made at the level of invention issued by the RSE «National Institute of Intellectual Property» of the Ministry of Justice of the Republic of Kazakhstan.

The limitations of this study are the high percentage of waterjet media transported, which limits the service life of pumping units, which is the subject of further research.

Promising directions of further research can be the development of 3D technology for manufacturing the main parts of ground pumps: snail, impeller, armored disk, housing, with pre-determined requirements of high wear resistance. Also it is necessary to carry out research on physical influence on a transported material and the pump unit by elastic, wave influences.

The process of operation of a centrifugal ground pump for the transportation of hydroabrasive mixture in the enrichment plant was studied.

Kazakhstan extracts a large amount of ore materials that are processed in order to extract valuable metals from them. In the process of processing rocks, the latter, in accordance with the technological process, are transported by centrifugal ground pumps. Thousands of ground pumps are used in the production process, their service life is very low, so the research of the operation of the centrifugal ground pump in order to increase its service life is an actual problem of mining and construction production.

The solution of the technological and structural task to increase the service life of the centrifugal ground pump, development of a new design of ground pumps with increased service life will allow to increase the production capacity, reduce overhaul cycles and the number of spare parts.

The research is a continuation of scientific research works of the «Standardization, certification and technology of mechanical engineering» faculty and, now, is a theme of the doctoral dissertation of the faculty applicant.

8. Conclusions

1. The analysis of the processes of water-abrasive wear and cavitation erosion of the working parts of ground pumps, the reasons for their appearance, the nature of wear and methods of their prevention, as a change in the modes of their operation, and design solutions is made. On the basis of the analysis of wear of parts of the ground pump flowing part, the advanced designs of the prefabricated armored disk with a replaceable disk, and the compound impeller with the improved indicators of wear resistance and maintainability are developed, allowing to increase their service life, to reduce expenses on purchase of spare parts, to reduce the repair period. The influence of the ground pump parts wear on its operating parameters is determined, the dependence of the pump head and flow rate on the volume of the pumped hydroabrasion mixture is established.

2. The influence of the hydraulic mixture characteristics and flow parameters on the ground pump wear has been established, analytical and experimental dependences of wear of the pump working parts – armour wheel and impeller – on the hydraulic mixture density and solid particles particle size have been found.

3. The main directions for increasing the service life of wearing parts, the choice of high-strength steel and wear-resistant coatings are defined. It also improves pump design and assesses the effect of physical fields on the transported material and pump unit. A laboratory experimental unit for laboratory tests has been developed: modes of operation of the pumping unit; the service life of the pumping unit in the conditions of water-abrasive wear of the ground pump have been determined. The basis for monitoring vibration parameters regulated by industry and international standards is statistical data on ground pump failures at mining and processing plants, which allows to predict the residual life of pumping units as a function of water-abrasive wear of the impeller.

References

1. Adistiya, S., Wijayanta, A. T. (2019). Effect of Clearance Gap on Hydraulic Efficiency of Centrifugal Pump. AIP Conference Proceedings 2097. doi: <https://doi.org/10.1063/1.5098228>
2. Povetkin, V. V., Kerimzhanova, M. F., Orlova, Y. P., Bukayeva, A. Z. (2018). Improvement of equipment for transport of slurry in mineral processing production. Mining Informational and Analytical Bulletin, 6, 161–169. doi: <https://doi.org/10.25018/0236-1493-2018-6-0-161-169>
3. Selamat, F. E., Iskandar, W. H., Saffuan, B. (2012). Design and Analysis of Centrifugal Pump Impeller for Performance Enhancement. Journal of Mechanical Engineering, SI 5(2), 36–53.
4. Ragoth Singh, R., Nataraj, M. (2014). Design and analysis of pump impeller using SWFS. World Journal of Modelling and Simulation, 10 (2), 152–160.
5. Remaki, L., Ramezani, A., Blanco, J. M., Garcia, I. (2017). New Simplified Algorithm for the Multiple Rotating Frame Approach in Computational Fluid Dynamics. Journal of Fluids Engineering, 139 (8). doi: <https://doi.org/10.1115/1.4036300>
6. Aleksandrov, V. I., Sobota, J. (2016). Vibrodiagnostics of the technical state slurry pumps. Journal of mining institute, 218, 242–250.
7. Spence, R., Amaral-Teixeira, J. (2009). A CFD parametric study of geometrical variations on the pressure pulsations and performance characteristics of a centrifugal pump. Computers & Fluids, 38 (6), 1243–1257. doi: <https://doi.org/10.1016/j.compfluid.2008.11.013>
8. Yao, N., Qiu, H., Xia, J., Sobota, J. (2018). Distribution of Solid Volume Concentration in the Cross-section of a Square Conduit during Hydrotransport of a Coarse Mixture. Ochrona Srodowiska, 40 (3), 47–52.
9. Aleksandrov, V. I., Vasilyeva, M. A. (2018). Hydraulic transportation of thickened tailings of iron ore processing at kachkanarsky gok based on results of laboratory and pilot tests of hydrotransport system. Journal of mining institute, 233, 471–479. doi: <http://dx.doi.org/10.31897/pmi.2018.5.471>
10. Shen, Z., Chu, W. (2018). Effect of Particle Parameters on Erosion Wear and Performance of Screw Centrifugal Pump. Volume 7: Fluids Engineering. doi: <https://doi.org/10.1115/imece2018-88586>

11. Li, H., Yu, B., Qing, B., Luo, S. (2017). Cavitation pulse extraction and centrifugal pump analysis. *Journal of Mechanical Science and Technology*, 31 (3), 1181–1188. doi: <https://doi.org/10.1007/s12206-017-0216-z>
12. Gülich, J. F. (2010). *Centrifugal Pumps*. Springer. doi: <https://doi.org/10.1007/978-3-642-12824-0>
13. Smirnov, N. I., Grigoryan, E. E. (2019). Study of the Impact of Wear of Movable Interfaces on Failures of an Immersible Electrically Operated Vane Pump for Oil Extraction. *Journal of Machinery Manufacture and Reliability*, 48 (1), 79–83. doi: <https://doi.org/10.3103/s105261881901014x>
14. Olimstad, G., Osvoll, M., Finstad, P. H. E. (2018). Very Low Specific Speed Centrifugal Pump-Hydraulic Design and Physical Limitations. *Journal of Fluids Engineering*, 140 (7). doi: <https://doi.org/10.1115/1.4039250>
15. Guelich, J. F., Bolleter, U. (1992). Pressure Pulsations in Centrifugal Pumps. *Journal of Vibration and Acoustics*, 114 (2), 272–279. doi: <https://doi.org/10.1115/1.2930257>
16. Yao, Z., Wang, F., Qu, L., Xiao, R., He, C., Wang, M. (2011). Experimental Investigation of Time-Frequency Characteristics of Pressure Fluctuations in a Double-Suction Centrifugal Pump. *Journal of Fluids Engineering*, 133 (10). doi: <https://doi.org/10.1115/1.4004959>
17. Zhang, N., Yang, M., Gao, B., Li, Z., Ni, D. (2015). Experimental Investigation on Unsteady Pressure Pulsation in a Centrifugal Pump With Special Slope Volute. *Journal of Fluids Engineering*, 137 (6). doi: <https://doi.org/10.1115/1.4029574>
18. Wu, Y., Chen, X., Dou, H.-S., Zheng, L., Zhu, Z., Cui, B., Khoo, B. C. (2017). Numerical simulation and analysis of flow characteristics in the front chamber of a centrifugal pump. *Journal of Mechanical Science and Technology*, 31 (11), 5131–5140. doi: <https://doi.org/10.1007/s12206-017-1007-2>
19. Povetkin, V. V., Lem, V. P. (2010). Pat. No. 23554 RK. Gruntoviy nasos. published: 15.12.2010, Bul. No. 12.
20. Povetkin, V. V., Lem, V. P. (2011). Pat. No. 24120 RK. Gruntoviy nasos. published: 15.06.2011, Bul. No. 6.
21. Grigoriev, S., Mayorov, S., Polyakov, R. (2017). Centrifugal pump's impeller optimization using methods of calculation hydrodynamics. *IOP Conference Series: Materials Science and Engineering*, 233, 012009. doi: <https://doi.org/10.1088/1757-899x/233/1/012009>
22. Caridad, J. A., Kenyery, F. (2005). Slip Factor for Centrifugal Impellers Under Single and Two-Phase Flow Conditions. *Journal of Fluids Engineering*, 127 (2), 317–321. doi: <https://doi.org/10.1115/1.1891153>
23. Pagalthivarathi, K. V., Furlan, J. M., Visintainer, R. J. (2017). Effective Particle Size Representation for Erosion Wear in Centrifugal Pump Casings. *Proceedings of the ASME fluids engineering division summer meeting*. doi: <https://doi.org/10.1115/fedsm2017-69240>
24. Zhou, F.-M., Wang, X.-F. (2016). Effects of staggered blades on the hydraulic characteristics of a 1400-MW canned nuclear coolant pump. *Advances in Mechanical Engineering*, 8 (8), 168781401665794. doi: <https://doi.org/10.1177/1687814016657944>
25. Kocaaslan, O., Ozgoren, M., Aksoy, M. H., Babayigit, O. (2016). Experimental and Numerical Investigation of Coating Effect on Pump Impeller and Volute. *Journal of Applied Fluid Mechanics*, 9 (7), 2475–2484. doi: <https://doi.org/10.18869/acadpub.jafm.68.236.25094>