

Increasing of Channel Carrying Capacity in 4G Mobile Communication Using MIMO OFDM

¹Mr. Khan Mustafa Nadeem , . ²Prof. C. S Khandelwal , ³Prof. F.I Shaikh

Electronics Engineering Department, Jawaharlal Nehru College of Engineering, Aurangabad

Abstract—

Since time immortal humans were and are always in search of simplest and the most effective mode of communication systems. Whether it is speech or gadgets used to process in the form of information or data. Similarly in telecommunication there is always need of fast data transfer thereby increasing the need of larger bandwidth and the technologies used to achieve the desired goal .Hence OFDM has been introduced for many existing and future communications systems throughout the world. It is well suited for systems in which the channel characteristics make it difficult to maintain ample amount of communications link performanc . In addition to high speed wireless applications, wired communication systems such as asynchronous digital subscriber line (ADSL) and cable modem uses OFDM as its underlying technology to provide a technique for delivering high-speed data communication. In this research , Our main aim is to implement a MIMO OFDM baseband transceiver on an FPGA by proper selection of one of the sixteen configurations to fulfill the need of faster data transmission on a wireless communication system with comparatively low prices of hardware implementation Moreover the implementation on FPGA is better than on a general purpose MPU in terms of speed and on ASIC in terms on cost.FPGAis having the flexibility of reconfiguring by the base station to meet future requirements. This section deals with discussions and analysis on the simulation results that are obtained till date with the standard results in the future research area in order to achieve high throughput.

This investigation focus on the design of project and its model development using matlab Simulink, Xilinx and then implementing it on FPGA. This includes understanding of OFDM, its spectrum, symbol structure, and its applications.

Keywords: MIMO, OFDM matlab Simulink, Xilinx and FPGA.

1.Introduction-

The need for high-speed data transmission has been increased in recent years. The mobile telecommunication industry faces the problem of providing the technology that will be able to support a variety of services ranging from voice communication with a data transfer rate of a few kbps to wireless multimedia in which the rate is up to 2 Mbps. Many systems have been proposed and OFDM system has gained much interest for different reasons. Although OFDM was first developed in the 1960s, only in recent years, it has been recognized as an outstanding method for high-speed wireless data communication where its implementation relies on very high-speed digital signal processing. This method has only recently become available with reasonable prices versus performance of hardware implementation.

Since OFDM is carried out in the digital domain, there are several methods to implement the system. One of the methods to implement the system is using ASIC (Application Specific Integrated Circuit). ASICs are the fastest, smallest, and lowest power way to implement OFDM into hardware. The main obstacle using this technique is inflexibility of design process associated and the comparatively longer time to market period for the designed chip.

Another method that can be utilized to implement OFDM is general purpose Microprocessor or Micro Controller. The processors are highly programmable and flexible in case of changing the OFDM design into the system. The shortcoming of using this hardware is that, it needs memory and other peripheral chips to support the operation. Moreover, it uses the most power usage and memory space, and would be the slowest in term of time to produce the output compared to other hardware.

Field-Programmable Gate Array (FPGA) is an example of VLSI circuit. This hardware is reprogrammable and the designer has full control over the actual design implementation without the need (and delay) for any physical IC fabrication facility. An FPGA combines the

speed, power, and density properties of an ASIC with the programmability of a general purpose processor will give advantages to the OFDM system. An FPGA could be reprogrammed for new functions by a base station transceiver system to meet upcoming needs particularly when new design is going to fabricate into chip. This will be the best choice for OFDM implementation since it gives flexibility to the program design besides the low cost hardware component comparatively.

2. Research details.

2.1 Block Diagram of 802.11n System

The overall system is split into two main parts: the transmitter and the receiver. The figure1 shows the MIMO transmitter of OFDM transceiver

2.1.1 Scrambler:

The scrambler transposes or inverts signals or otherwise encodes a message at the transmitter to make the message unintelligible at a receiver not equipped with an appropriately set of descrambling device. Scrambling is accomplished by the addition of components to the original signal or the changing of some important component of the original signal in order to make extraction of the original signal difficult.

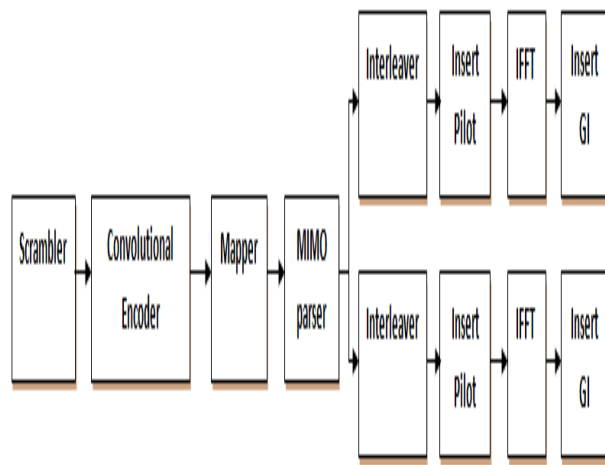

Fig2.1 802.11n System Transmitter block diagram.

2.1.2 Convolutional Encoder:

The data bits are encoded using a convolutional encoder. Convolutional encoding with Viterbi decoding is a FEC technique that is particularly suited to a channel in which the transmitted signal is corrupted mainly by additive white gaussian noise.

2.1.3 Mapper:

According to the modes of operation the data bits are punctured and mapped with QPSK constellations mentioned as per the standard. Puncturing is the process of removing some of the parity bits. This has the same effect as encoding with an error-correction code with a higher rate, or less redundancy. Thus puncturing considerably increases the flexibility of the system without significantly increasing its complexity. Puncturing increases the data rate defined as incase for rate $2/3$ which indicates transmitting 3 bits and taking 2 at the output. The data thereby is sent to Multiple- Input Multiple-Output (MIMO) parser.

2.1.4 MIMO Parser:

The MIMO parser performs different operations on input data bits. This operation is based on Space Time Coding (STC) or Spatial Multiplexing (SM). Among the most important STC's are the Alamouti and trellis codes. The D-BLAST and V-BLAST methods are among the most important methods in Spatial Multiplexing [2]. A parser segments a long bit stream into multiple spatial data streams. The multiple spatial data streams are applied to multiple interleavers.

2.1.5 Interleaver:

The interleaver thereby interleaves the bits which correspond to spatial data stream by performing multiple column rotation to increase diversity of the wireless system. There are different types of interleavers such as row-column, helical, odd-even and pseudo-random interleavers. An example of row-column interleaver is shown in the figure1. The interleaver design considers data bits in order to change burst errors of channel into separated error which can be easily detected.

2.1.6 Insert Pilot:

By Insert Pilot it is possible to prevent Inter carrier interface (ICI). The pilot inserted to the corresponding sub carriers is used for channel estimation.

2.1.7 Insert Guard Interval:

The spectra of an OFDM signal is not strictly band limited, linear distortion such as multipath cause each sub-channel to spread energy into the adjacent channels and consequently cause Inter Symbol Interference (ISI). The guard interval is inserted in order to avoid Inter Symbol Interference. A system without a guard interval has a significantly lower bit error rate and requires less bandwidth [2].

Multiple-Input-Multiple-Output (MIMO) antenna systems provide higher data rates up to 100Mbps. The combination of OFDM with MIMO results in less BER and improved Eb/No. At the receiver the blocks operation depends on the method used to code the signal in transmitter

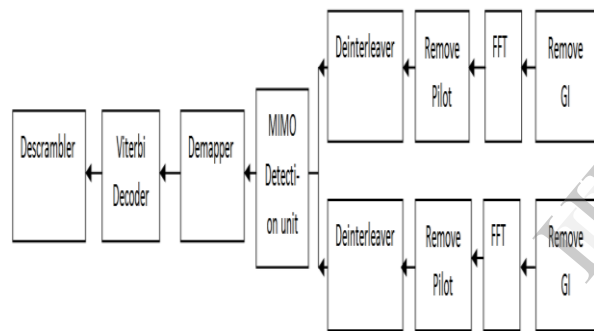

Fig.2.2 MIMO Receiver block diagram

The receiver has deinterleavers that deinterleave spatial bit streams transmitted by the transmitter. The detected signals are then decoded using a viterbi decoder and finally descrambled at the receiver end

A communications data stream is effectively divided into N parallel low bandwidth modulated data streams. Each sub-carrier overlaps, but they are all orthogonal to each other, such that they do not interfere with one another. Each of the sub-carriers has a low symbol rate. But the combination of sub-carriers carrying information in parallel allows for high data rates. The other advantage of a low symbol rate is that inter-symbol interference (ISI) can be reduced dramatically since the symbol time represents a very small proportion of the typical multipath delay

The transmitter stage of an OFDM transceiver takes data, converts, and encodes it into a serial stream before modulation. The OFDM signal is generated using an Inverse Fast Fourier Transform (IFFT). The receiver stage of the transceiver simply reverses the process.

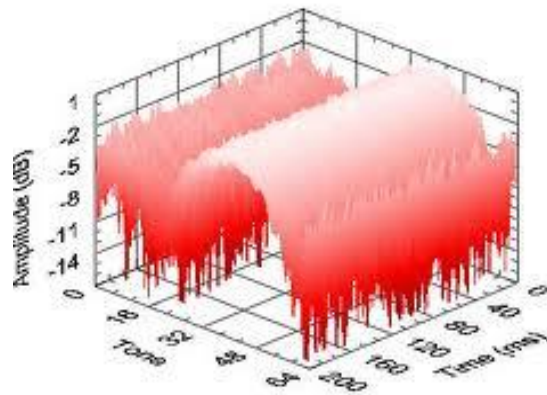

Fig.2.3: OFDM spectrum.

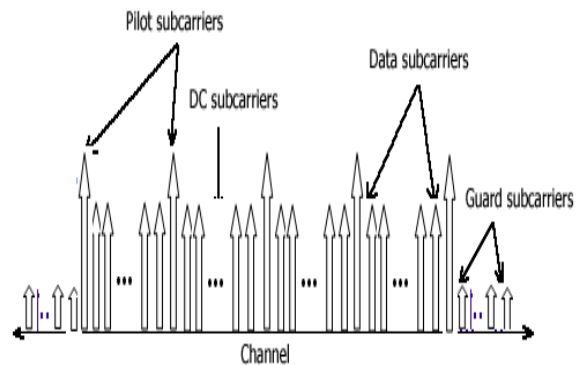

Fig.2.4: OFDM Symbol Structure

In OFDM each symbol consists of data sub-carriers frequencies that carry data, pilot sub-carriers as reference frequencies and for various estimation and analysis purposes, DC sub-carrier as the center frequency, and guard sub-carriers or guard bands for keeping the space between OFDM signals

3. LITERATURE SURVEY

3.1 MIMO:-Multiple Input Multiple Output

In MIMO technique, the system exploits the fact that the received signal from one transmit antenna can be quite different than the received signal from a second antenna. This is most common in indoor or densely populated metropolitan areas where there are many reflections and multipath between transmitter and receiver. In this case, a different signal can be transmitted from each antenna at the same frequency and still be recovered at the receiver by signal processing unit.

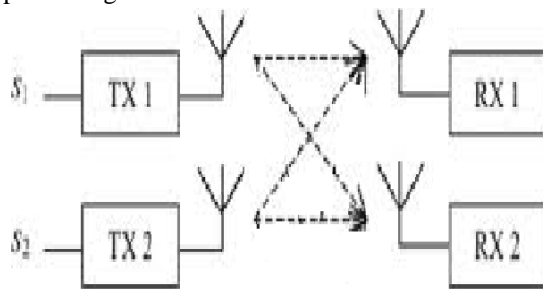

Fig.3.1 Transmit 2 Receive (2x2) MIMO channel.

3.3 MIMO-OFDM Systems

Multiple-input multiple-output (MIMO) systems are systems with multiple transmit antennas and multiple receive antennas. Compared with single-input single-output (SISO) systems, the technique of using multiple transmit and receive antennas can improve the performance and increase the capacity of mobile communication systems. The improvement depends on the employed number of transmit and receive antennas as well as on the propagation environment. The complexity of MIMO systems increases proportional to the number of transmit and receive antennas.

Orthogonal frequency division multiplexing (OFDM) is a special form of multi-carrier modulation with densely spaced sub-carriers and overlapping spectra. OFDM is the most appropriate modulation technique for wireless data transmission to overcome the influence of multipath propagation. Moreover, the OFDM modulator and demodulator can efficiently be implemented by using the inverse discrete Fourier transform in the transmitter

and the discrete Fourier transform in the receiver. The computational complexity is significantly reduced by the application of fast Fourier transform (FFT) techniques. Nowadays, OFDM has been chosen as the transmission method in digital audio broadcasting (DAB), terrestrial digital video broadcasting (DVB-T), high performance radio local area network type 2 (HiperLAN/2), digital radio mondiale (DRM), and asymmetric digital subscriber line (ADSL) systems, only to name a few.

To take profit from the advantages of the two techniques above, MIMO-OFDM systems are proposed. With these systems, the problem of intersymbol interference caused by multi-path propagation can be combated and the capacity can be increased. MIMO-OFDM systems are promising candidates for the transmission schemes of future wireless local area networks (WLAN) and other future high data rate mobile communication systems.

Planned Research – A MIMO-OFDM system with MT transmit and MR receive antennas using space-time coding is shown in Figs. 1a and 1b. At the transmit side, an input binary data sequence is encoded to MT different signals. Each of these signals forms an OFDM signal, which is then transmitted by the corresponding antenna over a MIMO channel. At the receive side, MR different signals are received. After the OFDM demodulation, MR demodulated signals are decoded to an output binary data sequence. In this area, our planned research topics include:

- System analysis and parameter optimization
- Channel estimation and synchronization
- Interference cancellation
- Space-time coding
- Implementation of MIMO-OFDM systems in digital signal processors (DSP).

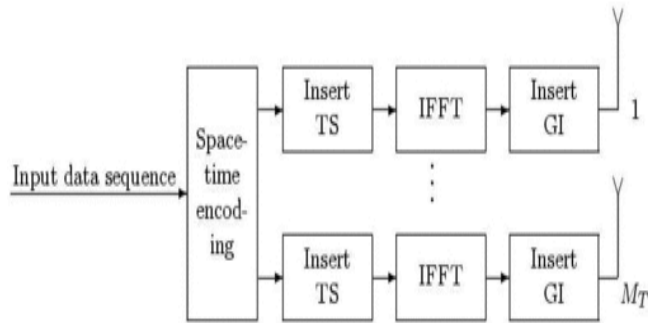

Fig. 3.2 MIMO-OFDM system consisting of a Transmitter with M_T antennas

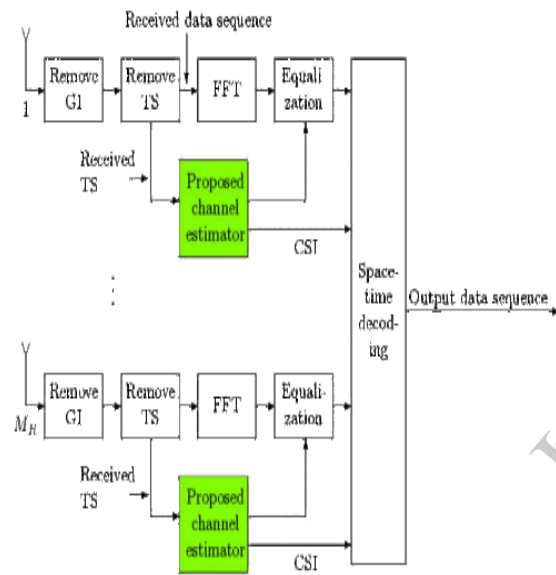

Fig. 3.3 MIMO-OFDM system consisting of a receiver with M_R antennas

4. Methodology for Design and Implementation:

The first stage will be verification of each block using matlab. The Matlab is multi-purpose software which is usually used for mathematical computation in the Electronics and Telecommunication Engineering field. After the algorithm is verified, the hardware implementation will be obtained by constructing block diagram in Simulink [5]. Then a VHDL code will be imported into Simulink via Xilinx system generator

block set which will create bit true and cycle accurate hardware model

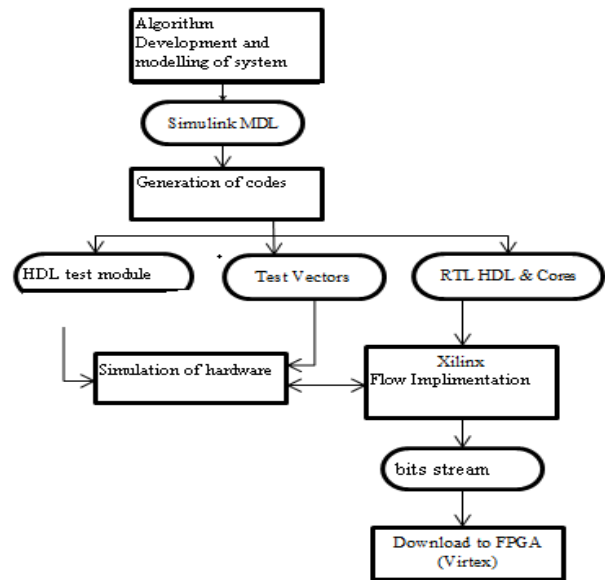

Fig.4.1 Methodology and flow diagram

The problem starts where one needs to select convolution encoder rate, constellation type and MIMO usage to ensure that the system works effectively [2]. For example in figure 5.2 we have selected convolution rate 1/2, 2/3 mapper and QAM constellation as it provides higher data rates. All block set function is implemented in the FPGA development board

4.1 Arrangement of subcarriers:

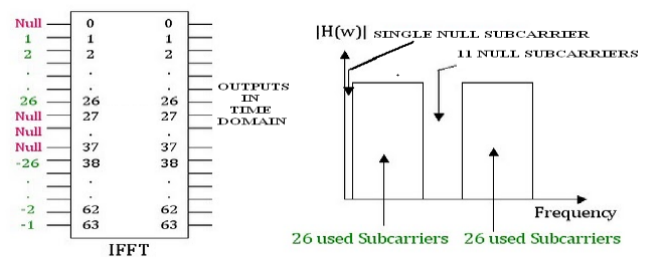

Fig.4.2 OFDM Subcarriers status

The IEEE 802.11 specification guides how to arrange the given subcarriers. The 52 used subcarriers (data + pilot) are assigned numbers from -26,-25...-2,-1 and 1, 2... 25, 26. The following figure illustrates the scheme of assigning these subcarriers to the IFFT inputs [1].

Table 4.1: OFDM Specifications

Given parameters in the condition:		Explanation
N = 64	=	Size of FAST FOURIER TRANSFORM(FFT) or total number of subcarriers (used + unused) are 64
Nsd = 48	=	Number of information subcarriers are 48
Nsp = 4	=	Number of pilot subcarriers are 4
Derived Parameters		
Ofdm BW = $20 * 10^6$	=	Bandwidth of OFDM
ΔF = ofdm BW/N	=	Each subcarriers Bandwidth Which - includes all used and unused subcarriers
T_{fft}	= $1/\Delta F$	IFFT or FFT Time period = $3.2\mu s$
T_{gi}	= $T_{fft}/4$	Guard band interval duration - duration of cyclic prefix - 1/4th portion of OFDM symbols
T_{signal}	= $T_{gi} + T_{fft}$	Total Time duration of OFDM symbol = Guard time + FFT period
N_{cp} = $N * T_{gi} / T_{fft}$	=	Number of symbols allotted to cyclic prefix
N_{st} = $N_{sd} + N_{sp}$	=	Total number of used subcarriers
$nBitsPerSym$ = N_{st}	=	For QPSK the number of Bits per Symbol is twice as number of subcarriers

5. Reported Results and discussion:

5.1 Simulation Result.

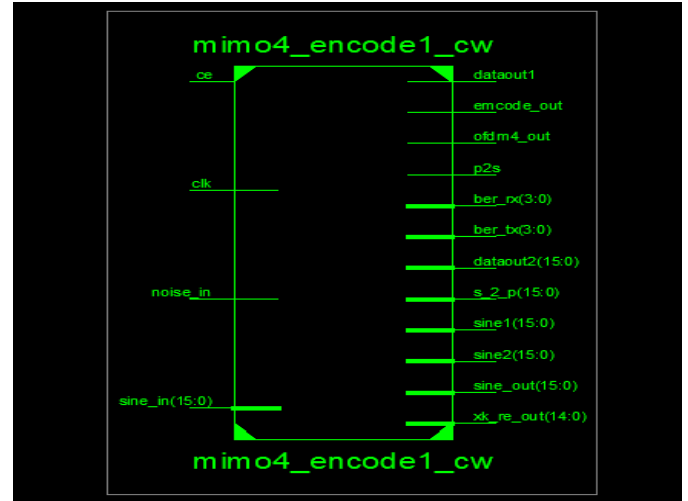

Fig 5.1 MIMO Schematic



5.2 Figure MIMO Package

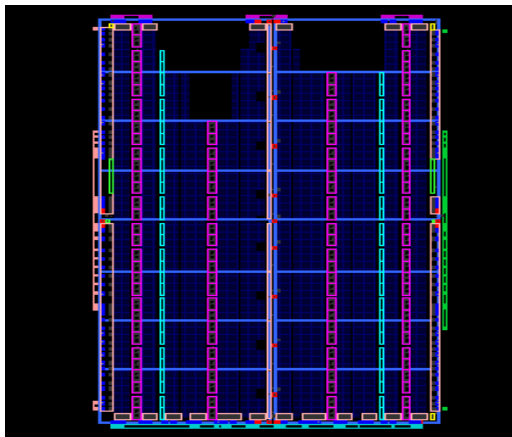

Fig 5.3 device

FPGA is superior method for implementation of OFDM compared to ASIC and Microprocessors. FPGA hardware is programmable and the designer has full control over the actual design implementation without the need (and delay) for any physical IC fabrication facility.

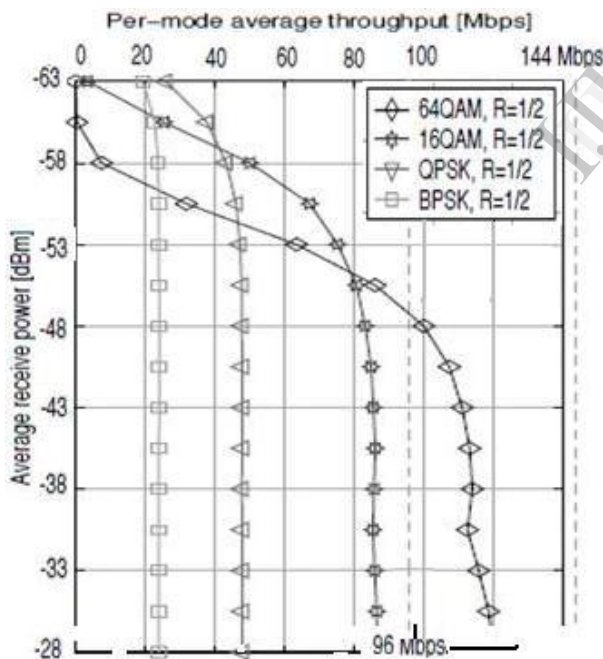

Fig 5.4. Actual Constellation Performance

Table 5.1 Constellation Performance

Constellation Of digital communication techniques	Code Rate	Data Rate in Mbps
64-QAM	1/2	120
16-QAM	1/2	88
QPSK	1/2	49
BPSK	1/2	25

The greater the number of symbols transmitted the higher data rates are achieved thus higher order QAM is used, however this scheme becomes more susceptible to ISI. The result shown above is for four transmit and four receive antennas. Thus proper selection of one of the sixteen configurations is important.

Our main aim is to implement a MIMO OFDM baseband transceiver on an FPGA by proper selection of one of the sixteen configurations to fulfill the need for high-speed data transmission for a wireless communication system with reasonable prices of hardware implementation.

In figure 5.1 we have different data rates which are achieved till date by using different constellation types.

6. Conclusion.

OFDM systems are the answer to our ever increasing data rate needs by both the subscriber and as well as the telecom operator. By implementing a MIMO OFDM baseband transceiver on an FPGA by proper selection of one of the sixteen configurations we expect to fulfill the need for high-speed data transmission for a wireless communication system with reasonable prices of hardware implementation. We understand the challenges and opportunities available in the technology. Moreover implementation on FPGA rather than on a general purpose MPU yields in terms of speed and on ASIC in terms on cost. Based on the more flexible properties , FPGA can be easily reconfigured by the base station to ever changing future demands.

The successful implementation of the transceiver on a FPGA would pave a way towards developing 802.11n modem. The architecture is applied for realization of 802.16 (Wi-max) and LTE(Long term evolution) transceivers. It intends to study various alternatives for implementation of the OFDM which results in reduced

chip size which by extension means cost reduction. Finally to develop a complete system of indigenously developed 802.11n modem which then results in robust, maximum throughput, highly scalable wireless LAN network.

References

[1] <http://gaussianwaves.blogspot.com/2011/07/simulation-of-ofdm-system-in-matlab-ber.html>

[2] Zoha Pajoudi, et. al., "Hardware Implementation of a 802.11n MIMO OFDM Transceiver," in IEEE Jour. 978-1-4244-2750-5. (2008)

[3] Yu Wei Lin Chen Yi Lin, "Design of FFT/IFFT Processor for MIMO OFDM Systems," IEEE Transaction on circuit and system, Vol.54, no. 4 pp. 807-815, 2007.

[4] Ashok Jhunjhunwala, "Next Generation wireless for rural areas," in Indian Journal of Radio and Space Physics, Vol.36. pp 165-167, 2007.

[5] K. C. Chang, et. al., "FPGA Based Design of a Pulsed-OFDM system," in IEEE Jour. 1-4244-0387-1/06.

[6] Z. Y. Ding, et. al. , "Design of a MIMO-OFDM baseband receiver for next generation wireless LAN ," in *Proc. of ISCAS 06*, vol. 1 , pp. 5650-5654, Island of Kos, Greece, 2006.

[7] K.C.Chang G.E. Sobelman, E Saberinia, and A.H. Tewfik, "Transmitter architecture for pulsed OFDM," IEEE APCCAS, 6-9 Dec. 2004, pp 693-696

[8] K. F. Lee, et. al., "A space-frequency transmitter diversity technique for OFDM systems," in *Proc. Globecom 03*, San Francisco, USA, vol.3, pp.24-28, 2003.

[9] D. Getsberg, et. al. , " From theory to practice: An overview of MIMO space-time coded wireless systems," in *IEEE Jour. Sel. Areas in Commun.*, vol.1.21, no. 38 pp. 281-301, 2003.

[10] V. Tarokh, et. al., "Space-time block coding for wireless communications: performance results," in *IEEE Jour. On Sel. Areas in Commun.*, vol 17, no. 3. pp. 451-460, 1999.

[11] S. M. Alamouti, "A simple transmit diversity scheme for wireless communications," in *IEEE Jour. Sel. Areas in Commun.*, vol.16, no. 8 pp. 1451-1458, 1998.

[12] Ramjee Prasad "OFDM for wireless communication system" Artech House, Inc. Boston, London.

[13] Hujun Yin, Sivash Alamouti, " OFDMA: A Broadband wireless Access Technology," Intel Corporation, Santa Clara CA 95054

[14] <http://en.wikipedia.org/>